

Procedures to File a Request to the Korean Intellectual Property Office for Patent Prosecution Highway Pilot Program between the Korean Intellectual Property Office and the Canadian Intellectual Property Office and

I. Purpose of the Document

This document aims to publicize the requirements and necessary documents for requesting participation in the Patent Prosecution Highway (PPH) pilot program between the Korean Intellectual Property Office (KIPO) and the Canadian Intellectual Property Office (CIPO) at the KIPO in order that an applicant is able to easily file a request for preferential examination under the PPH pilot program.

When an applicant files a request for preferential examination under the PPH pilot program to KIPO based on examination results by the CIPO, the PPH request should meet the requirements described in the below paragraph III.

II. Trial Period for the PPH Pilot Program

The PPH pilot program will commence on October 1, 2009, for a period of two years ending on September 30, 2011. The offices will evaluate the results of the pilot program to determine whether and how the program should be fully implemented after the trial period.

The trial period may be extended if necessary until the KIPO and the CIPO receive the sufficient number of PPH requests to adequately assess the feasibility of the PPH program. The Offices may also terminate the PPH pilot program early if the volume of participation exceeds manageable level, or for any other reason. Notice will be published if the PPH pilot program is terminated early.

III. Procedures to File a Request for Preferential Examination under the PPH Pilot Program

1. Basic Requirements for Requesting Preferential Examination under the PPH Pilot Program at the KIPO

There are five requirements for requesting preferential examination under the PPH pilot program at KIPO. An application must fulfill all five requirements listed below:

- (1) The KIPO application (including a PCT national phase application) is either:**
- (i) a national application which validly claims priority under the Paris Convention from either a single CIPO national application or multiple CIPO national applications (examples are provided in Annex I, Figure A, B, C), or
 - (ii) a PCT national phase application where the PCT international application has validly claimed priority from either a single CIPO national application or multiple national CIPO applications (examples are provided in Annex I, Figure D, E), or
 - (iii) a PCT national phase application where the PCT application has no priority claim (example is provided in Annex I, Figure F), or
 - (iv) a national application that validly claims priority under the Paris Convention from either a single PCT application with no priority claim or multiple PCT applications with no priority claims (example is provided in Annex I, Figure G), or
 - (v) a PCT national phase application where the PCT application validly claims priority from a PCT application which has no priority claims (examples are provided in Annex I, Figure H, I), or
 - (vi) a divisional application of an application as referred to in any of (i) to (v) (examples are provided in Annex I, Figure J).

Refer to Annex I for illustrated examples of the above applications.

- (2) The corresponding application(s) in the CIPO has claim(s) determined to be patentable/allowable at the examination stage in the CIPO.**

- 1) The patentable claims of the CIPO are the claims which are determined to be allowable when a CIPO examiner clearly identifies those claims to be allowable in the "Notice for Allowance" or in the CIPO Granted Patent.

The following cases are NOT eligible for the PPH:

A positive opinion is shown in the ISR, WO/ISA, WO/IPEA, IPER, or IPRP of the PCT international phase, but the CIPO has not determined the claims to be patentable/allowable yet.

- 2) "Corresponding application in the CIPO" should not be necessarily interpreted as the application which forms the basis of the priority, but may be the application which derived from the application which forms the basis of the priority or from the PCT application which has no priority claim; e.g., a divisional application of the application or an application which claims internal priority to the application.

Where the CIPO application that contains the patentable claims is not the same application for which priority is claimed in the KIPO application, applicant must identify the relationship between the CIPO application that contains the patentable claims and the CIPO priority application claimed in the KIPO application (eg CIPO application X that contains the patentable claims, claims domestic priority from CIPO application Y which is the priority application claimed in the KIPO application).

- (3) All claims in the KIPO applications must sufficiently correspond or be amended to sufficiently correspond to one or more of those claims determined to be patentable/allowable in the CIPO.**

- 1) Claims are considered to "sufficiently correspond" where the claims in the KIPO are the same or substantially same as the claims in the CIPO, or have additions or further limitations of specific features resulting that the claims in the KIPO fall within the scope of the claims in the CIPO.
- 2) A claim in the KIPO which introduces a new/different category of claims to those claims indicated as allowable in the CIPO is NOT considered to sufficiently correspond. For example, the CIPO claims only contain claims to a process of manufacturing a product, then the claims in the KIPO are not considered to sufficiently correspond if the KIPO claims introduce product claims that are dependent on the corresponding process claims.

- 3) Claims presented in a different claim format will be permitted if the change is a mere difference in translation and if the claims are still the same or similar scope.
- 4) It is not necessary to include “all” claims determined to be patentable/allowable in the CIPO in an application in the KIPO (the deletion of claims is allowable). For example, in the case where the corresponding application in the CIPO contains 5 claims determined to be patentable/allowable, the application in the KIPO may contain only 3 of these 5 claims. Please refer to ANNEX II for examples for the claim correspondence.

(4) Whether examination of the KIPO application for which participation in the PPH Pilot program has not begun does not affect eligibility for participation in the PPH pilot program.

It is possible to participate in the PPH not only when examination has not begun, but also when examination has already begun.

(5) A “Request for examination” must have been filed by the applicant in order to request the preferential examination under the PPH.

The preferential examination under the PPH pilot program must also be accompanied by, or preceded by a request for examination.

2. Documents Necessary to File a Request for Preferential Examination under the PPH Pilot Program at the KIPO.

Applicant must submit a “Request Form for Preferential Examination” and “The Explanation of Circumstances Concerning Preferential Examination under the PPH Pilot Program”. The documents (1) to (4) below must be submitted by attaching them to “The Explanation of Circumstances Concerning Preferential Examination”. Please refer to the ANNEX III for “The Explanation of Circumstances Concerning Preferential Examination under the PPH”.

(1) A claim correspondence table

- 1) Applicant must submit a claim correspondence table to explain the correspondence between all claims of the KIPO application for preferential examination under the PPH

and claims of the CIPO application which have been determined to be patentable/allowable in the CIPO.

- 2) Applicant must explain how all claims in the KIPO application sufficiently correspond to the patentable/allowable claims in the CIPO application in the table for each KIPO claims. Please see the example shown below in Annex III

(2) Copies and translations of all office actions in the CIPO

- 1) "Office action" means documents which are related to substantive examination and have been sent to an applicant from the CIPO examiner. The office action documents by the CIPO include all issued "Examiner's Report", a "Final Action Report", and a "Notice of Allowance".
- 2) An applicant who requests participation in the PPH is required to submit copies of the office action(s) because these documents are not available to the KIPO examiner.
- 3) The Korean or English is acceptable as translation languages. An applicant is required to submit Korean or English language translations of all office actions if these documents are written in French.
- 4) If it is impossible for the examiner to understand the translated office actions due to insufficient translation, the examiner may request the applicant to resubmit translations.
- 5) A request for PPH is not rejected because the translation is not enough to understand the translation.

(3) Copies and translations of claims determined to be patentable/allowable in the CIPO.

- 1) The copies of the claims determined to be patentable/allowable in the CIPO means either:
 - (i) copies of the document submitted at initial filing which includes claims determined to be patentable where no later amendments to the claims have been made; or
 - (ii) copies of the amendments which includes claims determined to be patentable where later amendments to the claims have been made; or
 - (iii) copies of the CIPO's publication of the granted patent.
- 2) An applicant who requests participation in the PPH is required to submit copies of the claims determined to be patentable/allowable in the CIPO because these documents are not available to the KIPO examiner.

- 3) The Korean or English is acceptable as translation languages. An applicant is required to submit Korean or English language translations of the claims determined to be patentable/allowable by CIPO if these claims are written in French.
- 4) If it is impossible for the examiner to understand the translated claims due to inadequate translation, the examiner can request the applicant to resubmit translations.
- 5) A request for the PPH is not rejected on the basis that the translation is not sufficient to understand the scope of the claims.

(4) Documents cited by the examiner in the CIPO

- 1) Documents to be submitted are those cited in the office action(s). Documents which are only referred to as references but are not cited in the office action need not be submitted.
- 2) If a cited document is non-patent literature, applicants will have to submit the document. If a cited document is a patent document, applicants usually do not have to submit it because the cited document is available to the KIPO. In the case where the KIPO examiner has difficulty in obtaining a document, the KIPO examiner will request the applicant to submit the document. Translations of the cited documents are not required.

3. Fee for Participation in the PPH

An applicant must pay the fee for preferential examination under the PPH same as other request for preferential examination.

4. Notes on Examination Procedures

The KIPO decides whether the application can undergo preferential examination under the PPH when it receives a request along with the documents stated above. When the KIPO decides that the request is acceptable, the application is assigned a special status for a preferential examination under the PPH.

The KIPO will not notify the applicant of the acceptance for assigning a special status for preferential examination under the PPH, but instead applicant may recognize it by the reception of an office action resulting from preferential examination.

In those instances where the request does not meet all the requirements set forth above, applicant will be notified and the defects in the request will be identified. Applicant may be given opportunity to perfect the request or may be required to submit a new request. If the PPH request is rejected, the applicant will be notified and the application will await examination in its regular turn.

ANNEX I

Examples of KIPO application eligible for the PPH

- (i) The national application which validly claims priority under the Paris Convention from either a single CIPO national application or multiple CIPO national applications

A Paris Route (Single Priority)

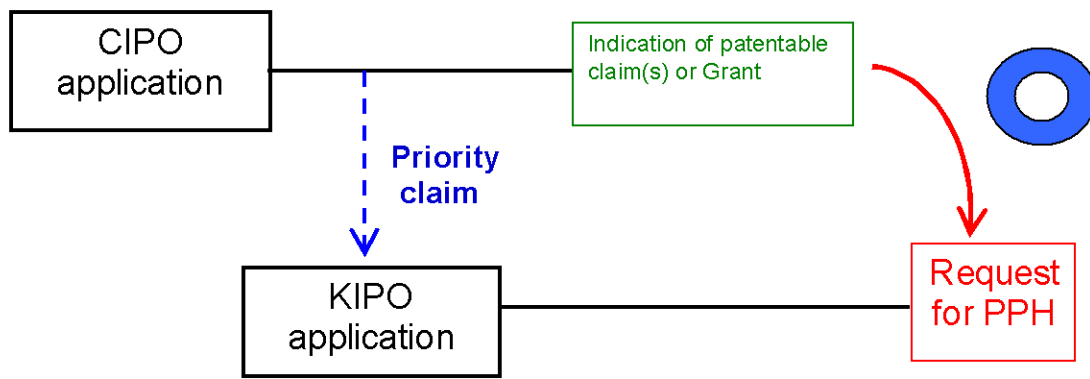

B Paris Route (Multiple Priority)

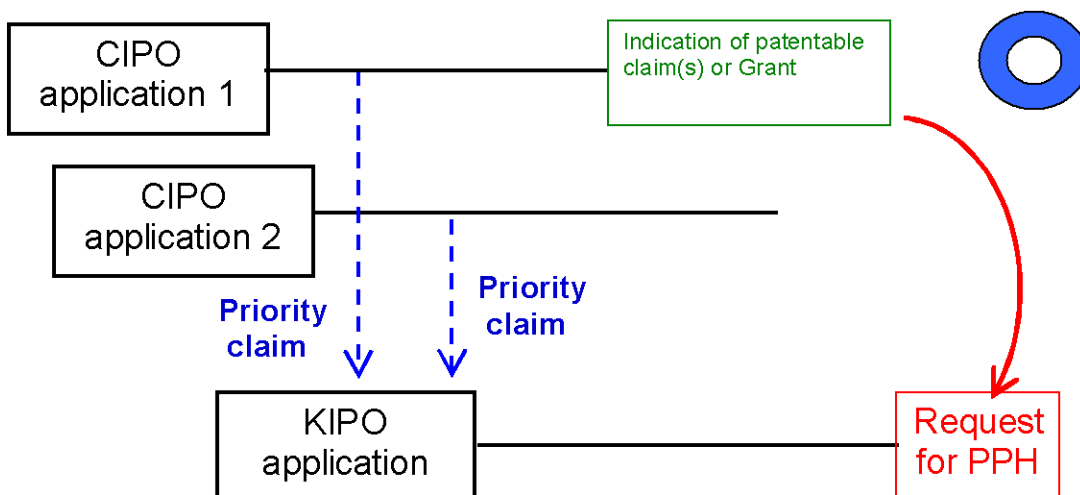

(i) (continued)

C Paris Route (Domestic Priority)

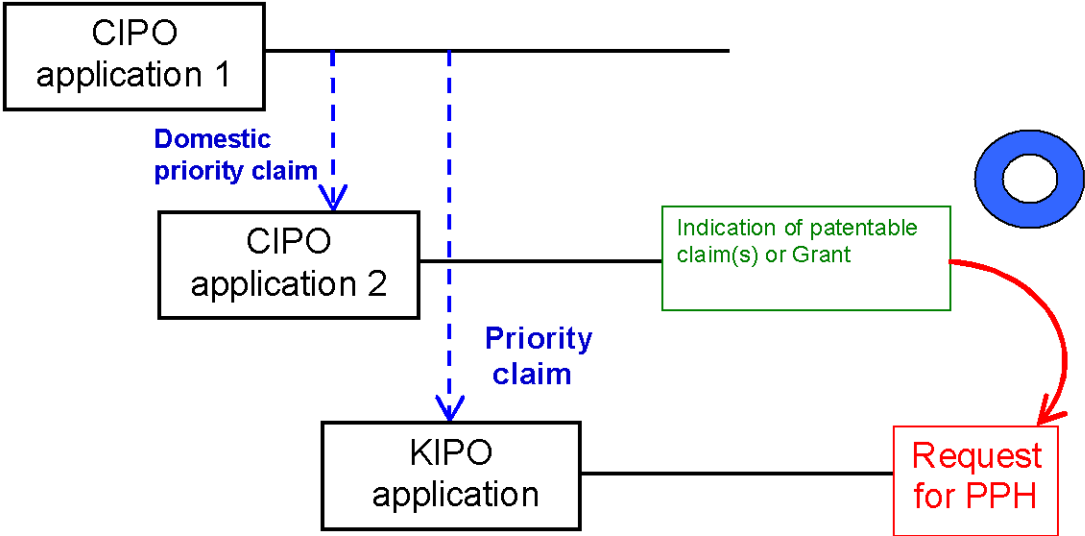

- (ii) The PCT national phase application where the PCT international application has validly claimed priority from either a single CIPO national application or multiple CIPO national applications

D PCT Route

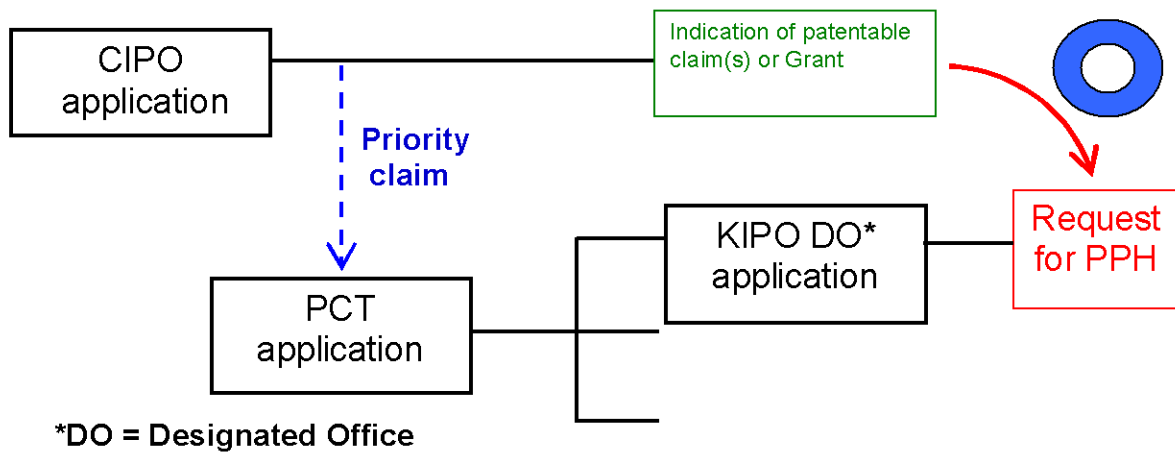

E PCT Route

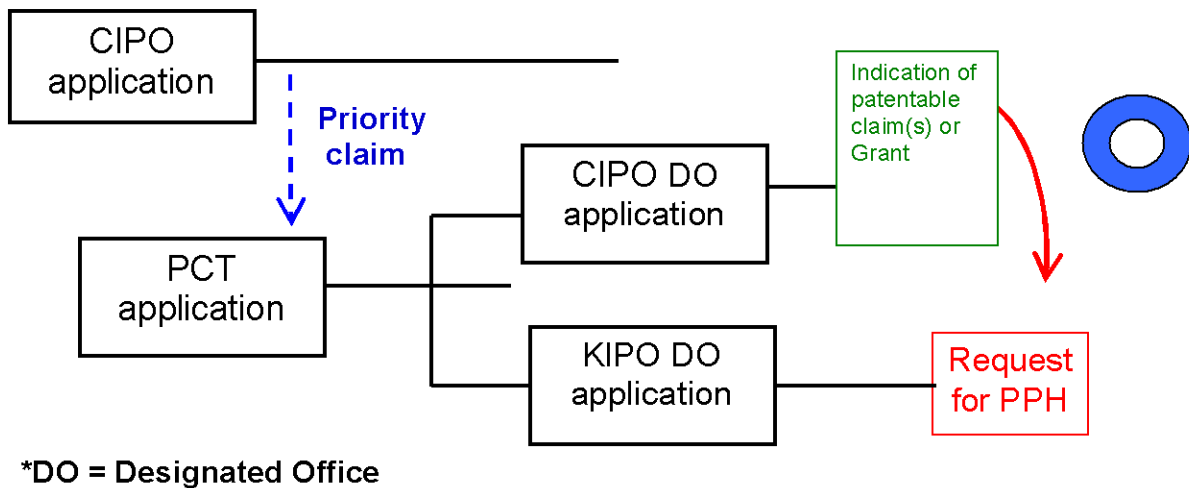

(iii) The PCT national phase application where the PCT application has no priority claim

F Direct PCT Route

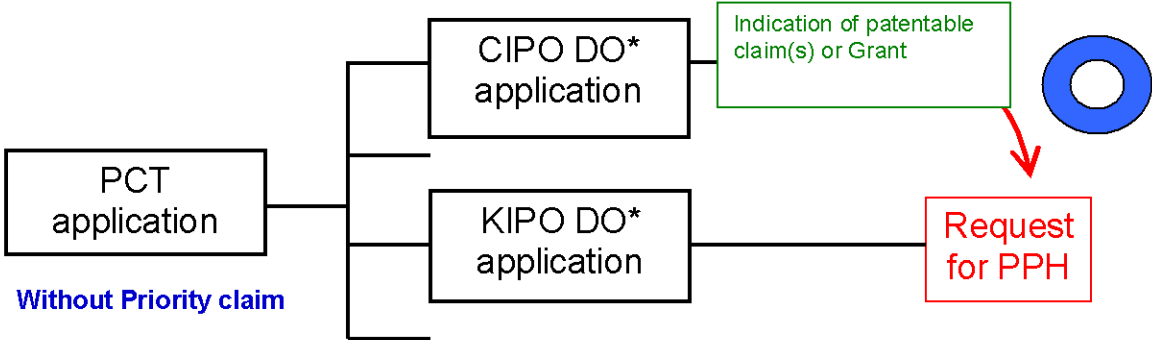

*DO = Designated Office

- (iv) The national application that validly claims priority under the Paris Convention from either a single PCT application with no priority claim or multiple PCT applications with no priority claims

G Direct PCT & Paris Route

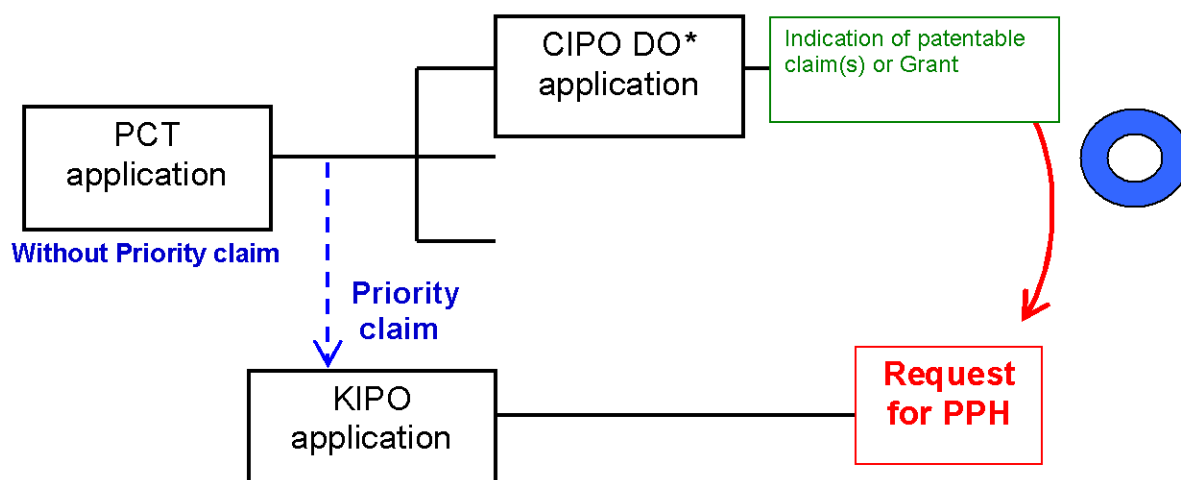

*DO = Designated Office

(v) The PCT national phase application where the PCT application validly claims priority from a PCT application which has no priority claims

H Direct PCT & PCT Route

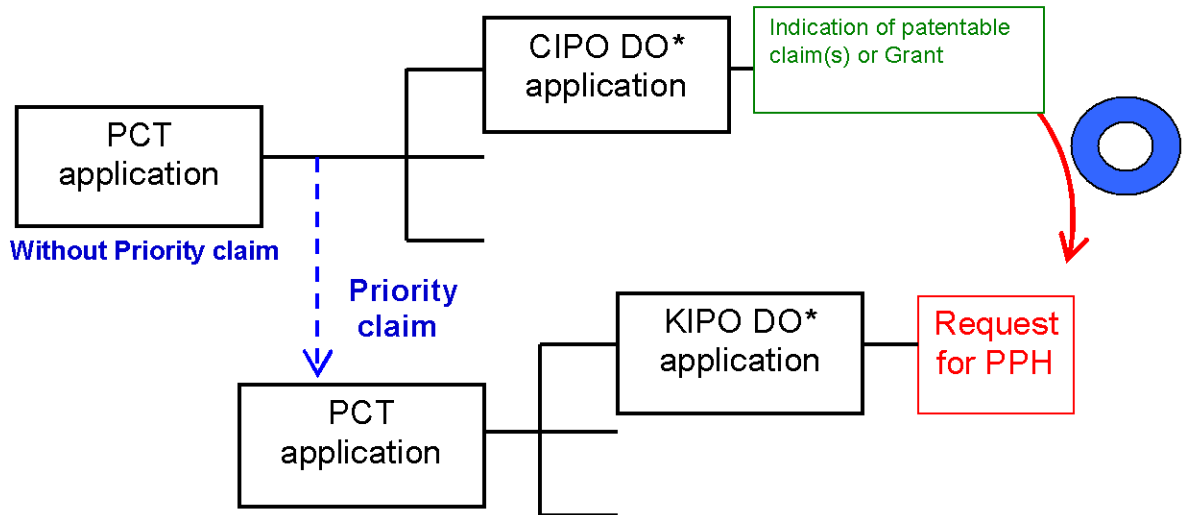

*DO = Designated Office

I Direct PCT Route & PCT Route

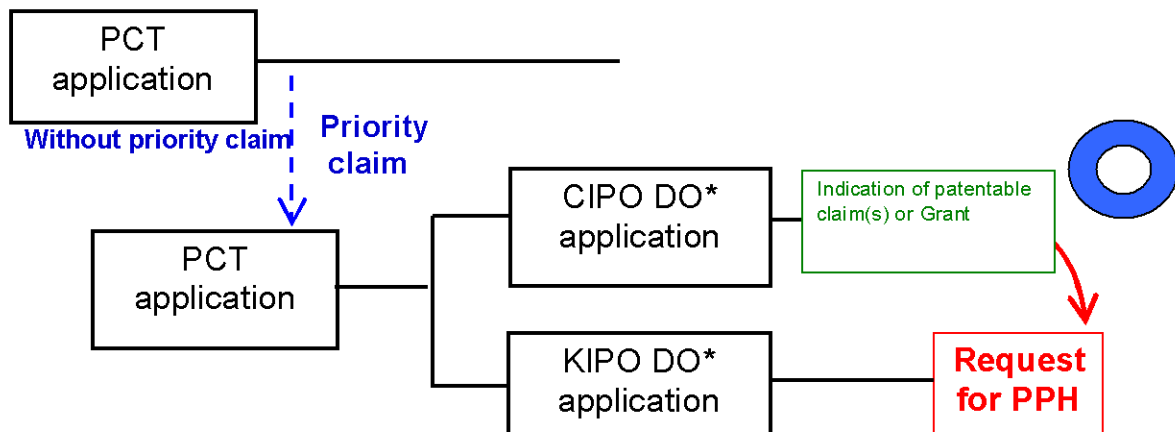

*DO = Designated Office

(vi) The divisional application of an application as referred to in any of (i) to (v)

J Paris (PCT) Route & Divisional Application

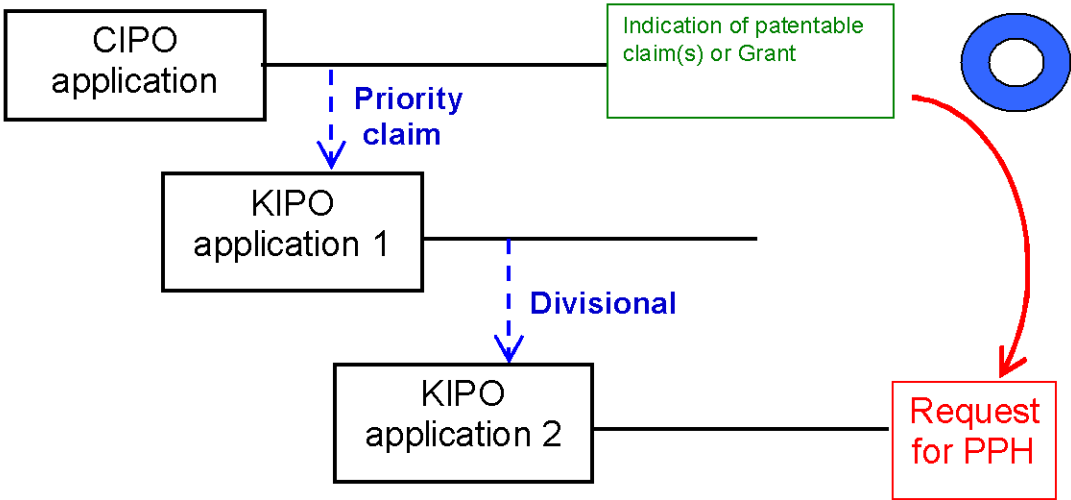

ANNEX II

Examples for the claim correspondence

- (1) The claims in the following cases (case 1 to case 4) are considered to “sufficiently correspond” to each other.

| Case | CIPO claim(s) | | KIPO claim(s) | | Correspondence |
|--------|---------------|----------------|---------------|----------------|--|
| | Claim | Subject matter | Claim | Subject matter | |
| Case 1 | 1 | A | 1 | A | The same as CIPO claim 1. |
| Case 2 | 1 | A | 1 | A | The same as CIPO claim 1. |
| | | | 2 | A+a | Dependent claim 2 in the KIPO claim is created by adding an element to the CIPO claim. |
| Case 3 | 1 | A | 1 | A | The same as CIPO claim 1. |
| | 2 | A+a | 2 | A+b | The same except for claim format. |
| | 3 | A+b | 3 | A+a | The same except for claim format. |
| Case 4 | 1 | A | 1 | A+a | Claim 1 has an additional element ‘a’ is added to the CIPO claim 1. |

** Where “A” is the subject matter, and “a” and “b” are the additional technical features which is supported in the description*

- (2) The claims in the following cases (case 5 and case 6) are NOT considered to “sufficiently correspond” to each other.

| Case | CIPO claim(s) | | KIPO claim(s) | | Explanation |
|--------|---------------|----------------|---------------|----------------|--|
| | Claim | Subject matter | Claim | Subject matter | |
| Case 5 | 1 | A system | 1 | A' method | The claimed invention of the KIPO application is a method, whereas the claimed invention of the CIPO application is a system. (The technical features in the CIPO claim are the same as those in the KIPO claim, but categories of both inventions are different) |
| Case 6 | 1 | A+B | 1 | A+C | The KIPO claim is different than the CIPO granted claim in a component of the claimed invention. (The KIPO claim is created by altering part of the technical features of the CIPO claim) |

ANNEX III

서면

[별지 제 3 호서식]

【서류명】 특허심사하이웨이(PPH)에 의한 우선심사신청설명서

【대상국가】

【본원출원번호】

【대응출원번호】

【본원출원과 대응출원의 관계】

【제출서류】

【특허가능하다고 판단된 특허청구범위】

【서류명 및 제출(발행)일】

【서류제출여부】

(**【제출생략 이유】**)

【번역문제출여부】

(**【제출생략 이유】**)

【심사관련통지서】

【서류명 및 통지일】

【서류제출여부】

(**【제출생략 이유】**)

【번역문제출여부】

(**【제출생략 이유】**)

【심사단계에서 인용된 선행기술문헌】

【명칭】

【제출여부】

(**【제출생략 이유】**)

【청구항간 대응관계설명표】

| 본원출원의 청구항 번호 | 대응출원에서 특허가능하다고 판단한 청구항 번호 | 대응관계 설명 |
|--------------|---------------------------|---------|
| | | |

※ 기재요령

1. 【대상국가】란에는 한국 특허청이 특허심사하이웨이를 시행하고 있는 대상국가(일본, 미국, 덴마크, 영국, 캐나다, 러시아) 중 어느 한 국가의 명칭 기재합니다.
2. 【대응출원번호】란에는 위 대상국가에서 특허가능하다고 판단한 특허청구범위를 포함하고 있는 특허출원의 출원번호 및 출원일을 적습니다.

예) 【대응출원】 JP 평 18-1234 호, 2007. 1. 1.

3. 【본원출원과 대응출원의 관계】란에는 위 대응출원과 본원출원간의 대응 관계를 명확하게 설명합니다. 대응출원에는 조약우선권 주장의 기초가 된 상대국의 특허출원뿐만 아니라 조약우선권 주장의 기초가 된 상대국의 특허출원과 연계되어 있음이 명확한 상대국의 다른 특허출원(예. 분할출원, PCT 국제출원의 조기 국내단계 진입출원)도 포함됩니다.

예) 【본원출원과 대응출원의 관계】 대응출원 JP 18-1234 은 본원출원(분할출원)의 원출원(KR10-2008-12345)이 조약 우선권주장하고 있는 상대국 특허출원 JP 17-5678 의 분할출원으로서 본원출원의 대응(패밀리)특허에 해당합니다.

4. 【특허가능하다고 판단된 특허청구범위】란에는 대상국가에서 특허가능하다고 판단한 특허청구범위가 기재된 서류명 및 제출 여부를 다음과 같이 기재합니다.

가. 【서류명 및 제출(발행)일】란에는 해당 특허청구범위가 기재된 서류의 종류와 제출일, 공보발간된 경우 공보번호와 공개일 등을 함께 기재합니다.

나. 【서류제출여부】란에는 ‘제출’로 기재하고 해당 특허청구범위를 첨부하여 제출합니다. 다만, 심사관이 정보통신망[예. AIPN(일본), public PAIR(미국), PVS online(덴마크) 등]을 통해 해당 특허청구범위를 용이하게 입수할 수 있는 경우에는 제출생략이 가능하므로 【서류제출여부】란에 ‘제출생략’으로 기재하고 【제출생략 이유】란에 생략 가능한 이유를 기재합니다.

다. 해당 특허청구범위가 국어 또는 영어가 아닌 언어로 작성된 경우에는 【번역문제출여부】란을 만들어 ‘제출’로 기재하고 국어 또는 영어로 번역된 번역문을 첨부하여 제출합니다. 다만, 심사관이 정보통신망에서 국어 또는 영어로 된 번역문을 확인할 수 있는 경우에는 제출생략이 가능하므로 【번역문제출여부】란에 ‘제출생략’으로 기재하고 【제출생략 이유】란에 생략 가능한 이유를 기재합니다.

라. 우선심사신청 후 심사관이 해당 특허청구범위를 입수할 수 없거나 국문 또는 영문 번역이 불충분하여 보완지시를 하는 경우에는 해당 서류를 보완하여 제출하여야 합니다.

예 1) 【서류명 및 발행일】 JP2000-123456(2000.01.01)

【서류제출여부】 제출생략

【제출생략 이유】 OOOO 을 통해 심사관이 입수 가능하므로 제출생략

【번역문제출여부】 제출생략

【제출생략 이유】 OOOO 에서 영어 번역문이 제공되므로 제출생략

예 2) 【서류명 및 제출일】 보정서, 2009.06.25 자로 일본특허청에 제출

【서류제출여부】 제출

【번역문제출여부】 제출

5. 【심사관련 통지서】란에는 대응출원에 대한 대상국가의 심사관이 통지한 실체심사 관련 서류명(거절결정서, 등록결정서, 의견제출통지서 등) 및 제출여부를 다음과 같이 기재합니다.

가. 【서류명 및 통지일】란에는 실체심사와 관련하여 통지된 서류의 명칭, 통지일 등을 기재합니다.

나. 【서류제출여부】란에는 ‘제출’로 기재하고 해당 심사관련 통지서를 첨부하여 제출합니다. 다만, 심사관이 정보통신망[예. AIPN(일본), public PAIR(미국), PVS online(덴마크) 등]을 통해 해당 심사관련 통지서를 용이하게 입수할 수 있는 경우에는 제출생략이 가능하므로 【서류제출여부】란에 ‘제출생략’으로 기재하고 【제출생략 이유】란에 생략 가능한 이유를 기재합니다.

다. 해당 통지서가 국어 또는 영어가 아닌 언어로 작성된 경우에는 【번역문제출여부】란을 만들어 ‘제출’로 기재하고 국어 또는 영어로 번역된 번역문을 첨부하여 제출합니다. 다만, 심사관이 정보통신망에서 국어 또는 영어로 된 번역문을 확인할 수 있는 경우에는 제출생략이 가능하므로 【번역문제출여부】란에 ‘제출생략’으로 기재하고 【제출생략 이유】란에 생략 가능한 이유를 기재합니다.

라. 우선심사신청 후 심사관이 해당 통지서를 입수할 수 없거나 국문 또는 영문 번역이 불충분하여 보완지시를 하는 경우에는 해당 서류를 보완하여 제출하여야 합니다.

예 1) 【서류명 및 통지일】 특허사정서, 2008.12.30

【서류제출여부】 제출생략

【제출생략 이유】 정보통신망을 통해 심사관이 입수 가능하므로 제출생략

【번역문제출여부】 제출

6. 【심사단계에서 인용된 선행기술문헌】란에는 심사관련 통지서에서 기재한 선행기술문헌의 명칭 및 제출여부를 다음과 같이 기재합니다.

가. 【명칭】란에는 인용된 선행기술문헌의 종류, 공개일(공보일)을 기재합니다.

나. 【서류제출여부】란에는 ‘제출’로 기재하고 해당 선행기술문헌을 첨부하여 제출합니다. 다만, 심사관이 해당 선행기술문헌을 용이하게 입수할 수 있는 특허문헌(비특허문헌은 제출)은 제출생략이 가능하므로 【제출여부】란에 ‘제출생략’으로 기재하고 【제출생략이유】란에 생략이유를 기재합니다.

예) 【명칭】 JP2000-123456(2000.01.01), US2004/348454(2004.05.04)

【제출여부】 제출생략

【제출생략이유】 특허문헌으로 용이하게 입수 가능하므로 제출생략

【명칭】 3GPP TR 29.802 v7.0.0 'Technical Specification Group Core Network and Terminals: (G)MSC-S-(G)MSC-S Nc Interface based on the SIP-I protocol, JUNE 2007(sections 5.7 and 5.8)

【제출여부】 제출

7. 【청구항간 대응관계설명표】란에는 본원출원의 모든 청구항에 대하여 대응되는 “대응출원의 특허가능하다고 판단한 청구항 번호”를 기재하여야 하며, 대응관계 설명 부분에는 양 청구항의 동일 여부 또는 차이점을 구체적으로 기재하여야 합니다.

예)

| 본원출원의 청구항 번호 | 대응출원에서 특허가능하다고 판단한 청구항 번호 | 대응관계 설명 |
|-----------------|------------------------------|------------------------------------|
| 1 | 1 | 양 청구항은 동일 |
| 2 | 2 | 〃 |
| 3 | 3 | 〃 |
| 4 | 5 | 양 청구항은 기재형식의 차이일 뿐 실질적으로 동일 |
| 5 | 6 | 〃 |
| 6 | 4 | 〃 |
| 7 | 1 | 청구항 7은 대응출원의 청구항 1에 A라는 구성이 추가됨 |