

Patent Prosecution Highway (PPH and PCT-PPH)
Pilot Program between the
Federal Service for Intellectual Property, Patents and
Trademarks of the Russian Federation (ROSPATENT)
and the *Spanish Patent and Trademark Office (SPTO).*

I. Patent Prosecution Highway Pilot Program

The PPH was established to enable an applicant whose claims are determined to be patentable/allowable in the Office of first filing (OFF) to have the corresponding application filed in the Office of second filing (OSF) advanced out of turn for examination while at the same time allowing the OSF to exploit the search and examination results of the OFF.

Where the SPTO is the OFF and the Spanish application contains claims that are determined to be patentable/allowable, the applicant may request accelerated examination at the Rospatent for the corresponding application filed with the Rospatent as the OSF. The procedures and requirements for filing a request with the Rospatent for participation in the PPH pilot program will be available from the Rospatent Web-site.

Where SPTO is the OSF and the corresponding application filed with the Rospatent as the OFF contains claims that are determined to be patentable/allowable, the applicant may request participation in the PPH pilot program in SPTO and petition to make the ES application special under the PPH pilot program. The procedures and requirements for filing a request in SPTO for participation in the PPH pilot program are set forth below.

The PCT-PPH pilot program was established to expand the potential of the PPH pilot program and to enable an applicant, who has received a Written Opinion from an International Searching Authority (WO/ISA), a Written Opinion from an International Preliminary Examining Authority (WO/IPEA), or an International Preliminary Examination Report (IPER) from an International Preliminary Examining Authority to file a corresponding request to the Office of Second Filing and a petition for examination, allowing the Office of Second Filing to use the result of the international search and examination.

II. Trial Period for the PPH Pilot Program

The PPH pilot program will commence on 04.04.2011 for a period of one year ending on 03.04.2012. The trial period may be extended for up to an additional year if necessary to adequately assess the feasibility of the PPH program. The SPTO and the Rospatent will evaluate the results of the pilot program to determine whether and how the program should be fully implemented after the

trial period. The Offices may also terminate the PPH pilot program earlier if the volume of participation exceeds manageable level, or for any other reason. Notice will be published if the PPH pilot program will be terminated before 03.04.2012.

Part I- PPH program using national work products from the ROSPATENT

Request to the SPTO

[0001] An applicant should file a request for accelerated examination under the Patent Prosecution Highway (PPH) to the SPTO by submitting an application requesting accelerated examination under the PPH accompanied by the relevant supporting documents. The requirements for an application to the SPTO for accelerated examination under the PPH are given in the following section. Relevant supporting documentation is discussed in a latter section (paragraphs [0003] to [0005]) as is the general SPTO application procedure envisaged at this time (paragraph [0006]).

Requirements for requesting an accelerated examination under the PPH Pilot Program at the SPTO

[0002] There are three requirements for requesting accelerated examination under the PPH pilot program at the SPTO. These are:

- a) Either:
 - i) the SPTO application validly claims priority under the Paris Convention from at least one corresponding ROSPATENT application;
 - ii) the SPTO application is the national phase of a PCT application which has no priority claims, or
 - iii) the SPTO application is the national phase of a PCT application which validly claims priority from a ROSPATENT national application, or
 - iv) the SPTO application claims priority from a PCT application which has no priority claims, or
 - v) the SPTO application is the national phase of a PCT application which validly claims priority from a PCT application which has no priority claims, or
 - vi) the SPTO application is a divisional application of any of the above.

Examples are provided in Annex 1.

- b) At least one corresponding ROSPATENT application has one or more claims that are determined to be patentable/allowable by the ROSPATENT
- c) All the claims on file, as originally filed or amended, for examination in the SPTO under the PPH must sufficiently correspond to one or more of those claims indicated as patentable/allowable by the ROSPATENT in order to

the SPTO application to qualify for accelerated examination under the PPH at the SPTO.

Claims are considered to 'sufficiently correspond' where, accounting for differences due to translations and claim format, the claims in the SPTO application are of the same or similar scope as in the ROSPATENT application, or the claims of the SPTO application are narrower in scope than the claims in the ROSPATENT application.

In this regard, a claim that is narrower in scope occurs when a ROSPATENT claim is amended to be further limited by an additional feature that is supported in the specification (description and/or claims). Narrower claims can be written as dependent claims.

A claim in the SPTO application which introduces a new/different category of claims to those claims indicated to be patentable/allowable in the ROSPATENT application is not considered to sufficiently correspond. If, for example, the ROSPATENT claims only contains claims to a process of manufacturing a product, then the claims in the SPTO application are not considered to sufficiently correspond if the claims of the SPTO application introduce product claims that are dependent on the corresponding process claims.

Any claims amended or added after the grant of the request for participation in the PPH Pilot Program need not to sufficiently correspond to the claims indicated as patentable/allowable in the ROSPATENT application.

Required documents for accelerated examination under the PPH Pilot Program at the SPTO

[0003] The following documentation will be needed to support a request for accelerated examination under the PPH pilot program at the SPTO:

- a) a copy of all the office actions (which are relevant to the patentability) in the corresponding ROSPATENT application(s), and translations of them. Office actions are documents which relate to substantive examination and which were sent to the applicant by the ROSPATENT examiner. The applicant can either provide these with the request for acceleration under the PPH or request that the SPTO obtain the documents required through the ROSPATENT document database.

Both Spanish and English are acceptable as translation language. Machine translations are admissible, but if it is impossible for the examiner to understand the outline of the translated office action or claims due to insufficient translation, the examiner can request the applicant to resubmit translations.

- b) a copy of the claims found to be patentable/allowable by the ROSPATENT and translations of them. The applicant can either provide these with the request for acceleration under the PPH or request that the SPTO obtain the documents required through the ROSPATENT document database. Both Spanish and English are acceptable as translation language. The indications provided in the requirement [0003](a) above regarding machine translations also apply to this requirement [0003](b).
- c) a complete claim correspondence table showing the relationship between the claims of the SPTO application for accelerated examination under the PPH and the claims of the corresponding ROSPATENT application considered patentable/allowable by the ROSPATENT. Sufficient correspondence of claims occurs where claims are of the same or similar scope.

The claims correspondence table must indicate how the claims in the SPTO application correspond to the patentable/allowable claims in the ROSPATENT application. The claim correspondence table must be written in Spanish or English.

- d) copies of the references cited by the ROSPATENT examiner. If the references are patent documents, it will not be necessary to submit these documents, as they will usually be available to the SPTO. If the SPTO does not have access to relevant patent documents, the applicant must submit these documents at the request of the SPTO. Non-patent literature must always be submitted. Translations of cited references are unnecessary.
- e) In those rare situations where the ROSPATENT application has not been published, and therefore the ROSPATENT file wrapper is not available via the ROSPATENT document database, the applicant will be responsible for providing the necessary documents to the SPTO.

[0004] The relevant information is obtained from the applicant by filling out a form for requesting accelerated examination under the PPH Pilot Program (see Annex 3) which is available on the SPTO web site. The relevant supporting documentation should be attached.

[0005] The applicant needs not provide further copies of documentation if they have already been submitted to the SPTO through simultaneous or past procedures.

Procedure for accelerated examination under the PPH Pilot Program at the SPTO

[0006] The applicant fills out the form requesting accelerated examination under the PPH Pilot Program available on the SPTO web page and includes all the relevant supporting documents. The PPH Administrator, who will be an SPTO patent examiner, will consider the request. Where all the requirements for

accelerated examination under the PPH have not been met, the PPH Administrator will notify the applicant that the application has not been allowed entry on to the PPH and will provide an explanation as to why entry on to the PPH was denied. The applicant is free to take any possible correcting action necessary and again requesting acceleration under the PPH.

If all requirements for accelerated examination under the PPH are met, the PPH Administrator will notify the applicant that the application has been allowed entry on to the PPH. The PPH Administrator will notify the relevant examining group that the application has qualified for entry to the PPH and the relevant examiner will then conduct an accelerated examination of the application.

If the request for accelerated examination is not granted, the applicant will be notified that the application will await action in its regular turn.

Part II- PPH using the PCT international work products from the ...

Request to the SPTO

[0001] An applicant can request accelerated examination by a prescribed procedure including submission of relevant documents on an application which is filed with the SPTO and satisfies the following requirements under the SPTO-ROSPATENT Patent Prosecution Highway Pilot Program based on PCT international work products (PCT-PPH Pilot Program).

The Offices may terminate the PCT-PPH Pilot Program early if the volume of participation exceeds manageable levels, or for any other reason. Notice will be published if the PCT-PPH Pilot Program is terminated.

Requirements for requesting an accelerated examination under the PCT-PPH Pilot Program at the SPTO

[0002] The application which is filed with the SPTO and on which the applicant files a request under the PCT-PPH must satisfy the following requirements:

- a) The latest work product in the international phase of a PCT application corresponding to the application ('international work product'), namely Written Opinion of International Search Authority (WO/ISA), the Written Opinion of International Examination Authority (WO/IPEA) or the Preliminary Examination Report (IPER), indicates at least one claim is patentable/allowable.

Note that the ISA and the IPEA which produce the WO/ISA, WO/IPEA and the IPER are limited to the ROSPATENT, but if priority is claimed, the priority claim can be referred to an application in any Office (see example A' in Annex II: Application ZZ can be any national application).

The applicant cannot file a request under PCT-PPH on the basis of an International Search Report (ISR) only.

In case any observation is described in Box VIII of WO/ISA, WO/IPEA or IPER which forms the basis of a PCT-PPH request, the applicant must explain why the claim(s) is/are not subject to the observation, irrespective of the fact that an amendment is submitted to correct the observation noted in Box VIII. The application will not be eligible for participating in the PCT-PPH Pilot Program if the applicant does not explain why the claim(s) is/are not subject to the observation. In this regard, however, it will not affect the decision on the eligibility of the application whether the explanation is adequate and/or whether the amendment submitted overcomes the observation in Box VIII.

- b) the relationship between the application and the corresponding international application satisfies one of the following requirements:
- i) the application is a national phase application of the corresponding international application (see figures A, A' and A'' in Annex 2)
 - ii) the application is a national application as a basis of the priority claim of the corresponding international application (see figure B in Annex 2)
 - iii) the application is a national phase application of an international application claiming priority from the corresponding international application (see figure C in Annex 2).
 - iv) The application is a national application claiming priority from the corresponding international application (See figure D in Annex 2)
 - v) The application is the derivate application (divisional application etc) of the application with satisfies one of the above requirements (i)-(iv) (See figure E in Annex 2).
- c) all claims, as originally filed or as amended, for examination under the PCT-PPH must sufficiently correspond to one or more of those claims indicated to be patentable/allowable in the latest international work product of the corresponding international application.

Claims are considered to 'sufficiently correspond' where, accounting for differences due to translations and claim format, the claims of the application are of the same or similar scope as the claims indicated to be patentable/allowable in the latest international work product, or the claims of the application are narrower in scope than the claims indicated to be patentable/allowable in the latest international work product.

In this regard, a claim that is narrower in scope occurs when a claim indicated to be patentable/allowable in the latest international product is amended to be further limited by an additional feature that is supported in the specification (description and/or claims) of the application. Narrower claims can be written as dependent claims.

A claim of the application which introduces a new/different category of claims to those claims indicated to be patentable/allowable in the latest international work product is not considered to sufficiently correspond. For example, the claims indicated to be patentable/allowable in the latest international work product only contains claims to a process of manufacturing a product, then the claims of the application are not considered to sufficiently correspond if the claims of the application introduce product claims that are dependent on the corresponding process claims.

Any claims amended or added after the grant of the request for participation in the PCT-PPH Pilot Program need not to sufficiently correspond to the claims indicated as patentable/allowable in the latest international product.

Required documents for accelerated examination under the PCT-PPH Pilot Program at the SPTO

[0003] The following documentation will be needed to support a request for accelerated examination under the PCT-PPH Pilot Program at the SPTO:

- a) a copy of the latest international work product which indicated the claims to be patentable/allowable and their Spanish or English translations if they are not in English.

In case the application satisfies the relationship [0002](b)(i), the applicant need not to submit a copy of the International Preliminary Report on Patentability (IPRP) and any English translations thereof because a copy of these documents is already contained in the file-wrapper of the application. In addition, if the copy of the latest international work product and the copy of the translation are available via 'PATENTSCOPE®', an applicant need not to submit these documents, unless otherwise requested by the SPTO.

(WO/ISA and IPER are usually available as 'IPRP Chapter I' and 'IPRP Chapter II' respectively in 30 months after the priority date).

- b) a copy of the set of claims which the latest international work product of the corresponding international application indicated to be patentable/allowable and their Spanish or English translations if they are not in Spanish.

If the copy of the set of claims which are indicated to be patentable/allowable is available via 'PATENTSCOPE®'¹, e.g. the international Patent Gazette has been published, the applicant need not submit this document unless otherwise requested by the SPTO.

- c) a copy of the references cited in the latest international work product of the international application corresponding to the application.

If the reference is a patent document, the applicant is not required to submit it. In case the SPTO has difficulty in obtaining the document, however, the applicant may be asked to submit it. Non-patent literature must always be submitted. Translations cited references are unnecessary.

- d) a complete claim correspondence table showing the relationship between the claims of the SPTO application for accelerated examination under the PCT-PPH and the claims indicated to be patentable/allowable.

¹ <http://www.wipo.int/pctdb/en/search-adv.jsp>

If the claims simply are literal translations, then it is sufficient that the applicant writes 'they are the same' in the table. If the claims are not literal translations, then it is necessary to explain the sufficient correspondence of each claim based on the criterion [0002](c).

[0004] When an applicant has already submitted the above mentioned documents (a)-(d) to the SPTO through simultaneous or past procedures, the applicant may incorporate the documents by reference and is thus not required to attached the documents.

Procedure for accelerated examination under the PCT-PPH Pilot Program at the SPTO

[0005] The applicant fills out the form requesting accelerated examination under the PCT-PPH Pilot Program (see Annex 4) available on the SPTO web page and includes all the relevant supporting documents. The PCT-PPH Administrator, who will be an SPTO patent examiner, will consider the request. Where all the requirements for accelerated examination under the PCT-PPH have not been met, the PCT-PPH Administrator will notify the applicant that the application has not been allowed entry on to the PCT-PPH and will provide an explanation as to why entry on to the PCT-PPH was not possible. The applicant is free to take any possible correcting action necessary and again requesting acceleration under the PCT-PPH.

Where all of the requirements for accelerated examination under the PCT-PPH have been met, the PCT-PPH Administrator will notify the applicant that the application has been allowed entry on to the PCT-PPH. The PCT-PPH Administrator will notify the relevant examining group that the application has qualified for entry to the PCT-PPH and the relevant examiner will then conduct an accelerated examination of the application.

If the request for accelerated examination is not granted, the applicant will be notified that the application will await action in its regular turn.

ANNEX 1

Examples of SPTO applications eligible for PPH.

- ES application with single Paris Convention priority claim to an application filed in ROSPATENT.

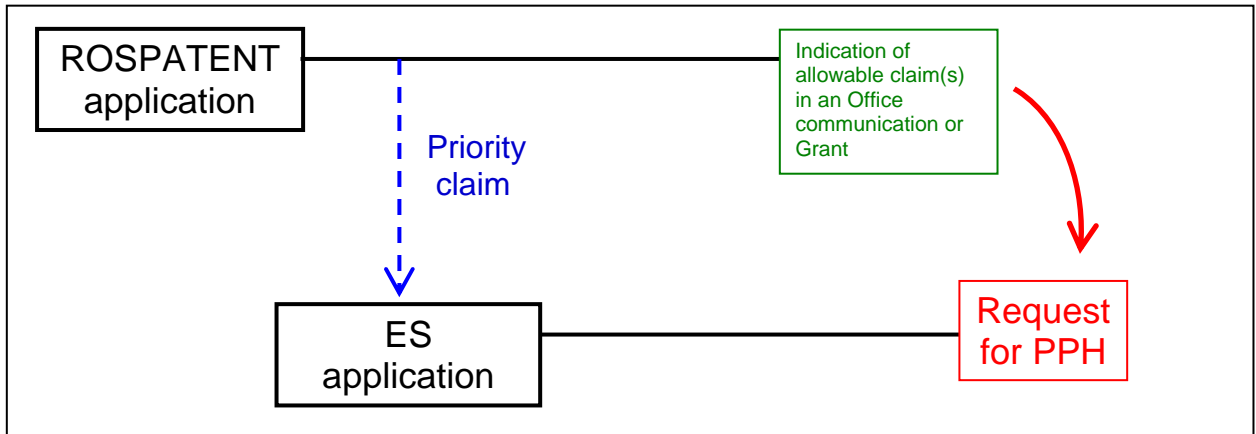

- ES application with a complex Paris Convention priority

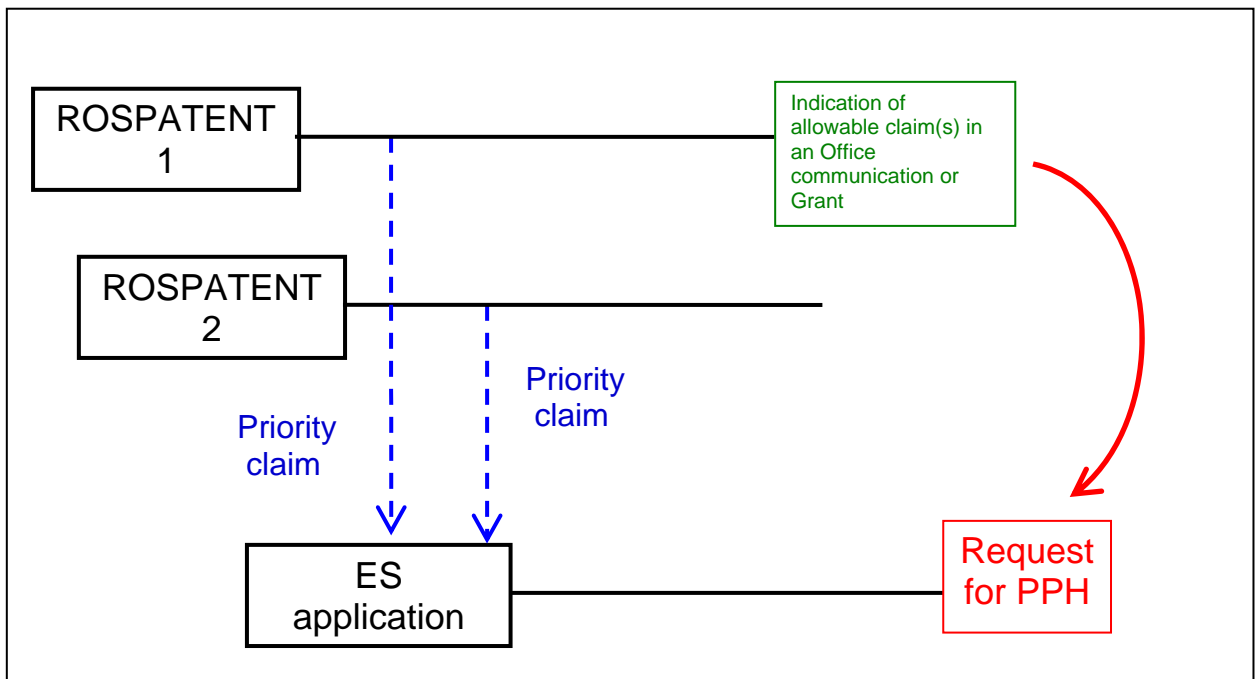

- Paris route and domestic priority

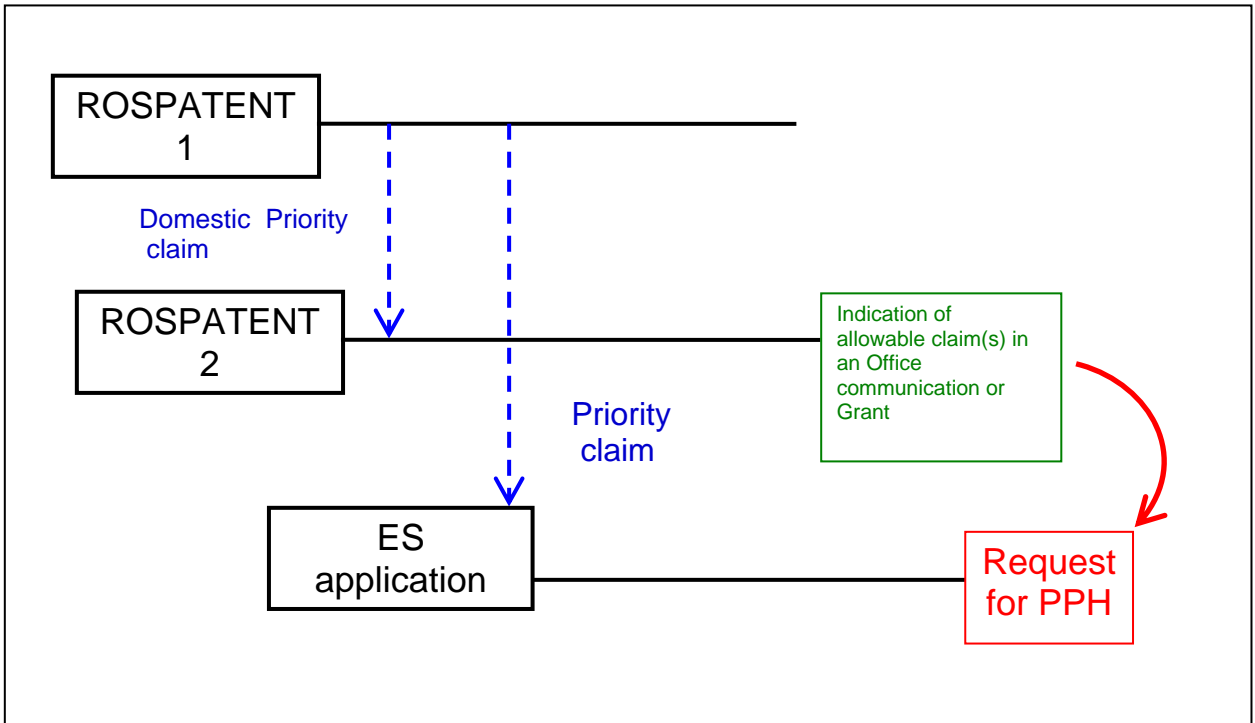

- Paris route and divisional application

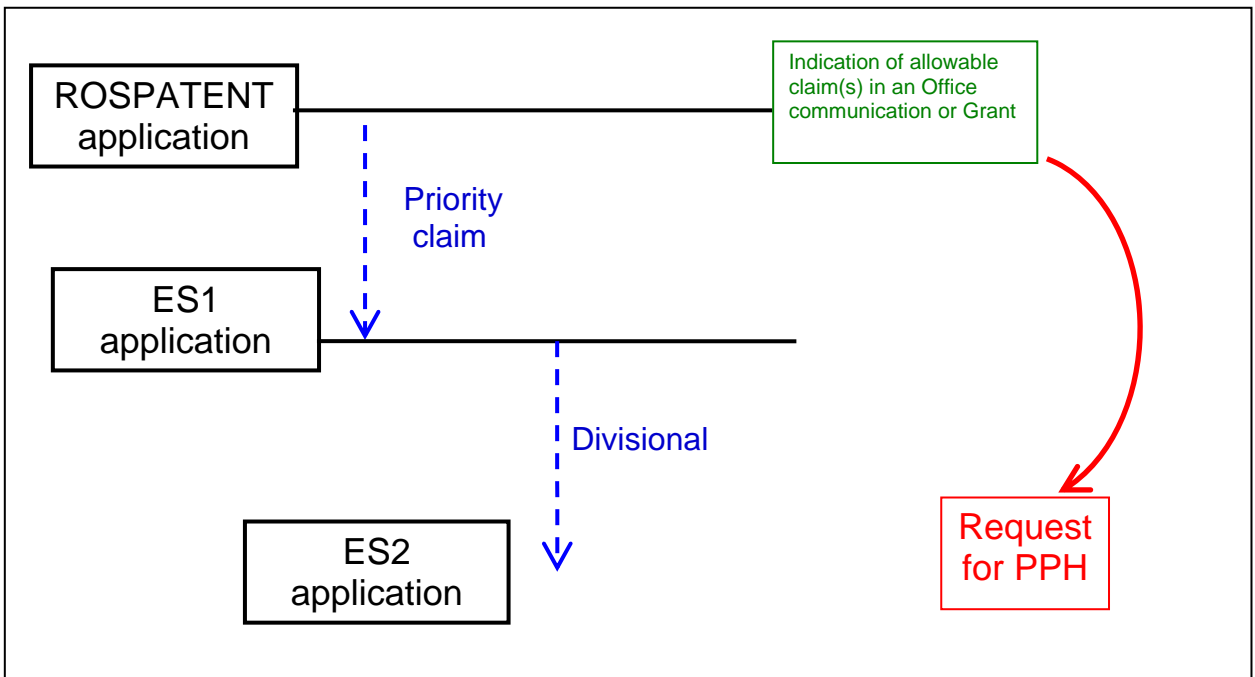

- ES application claims Paris Convention priority to a PCT application

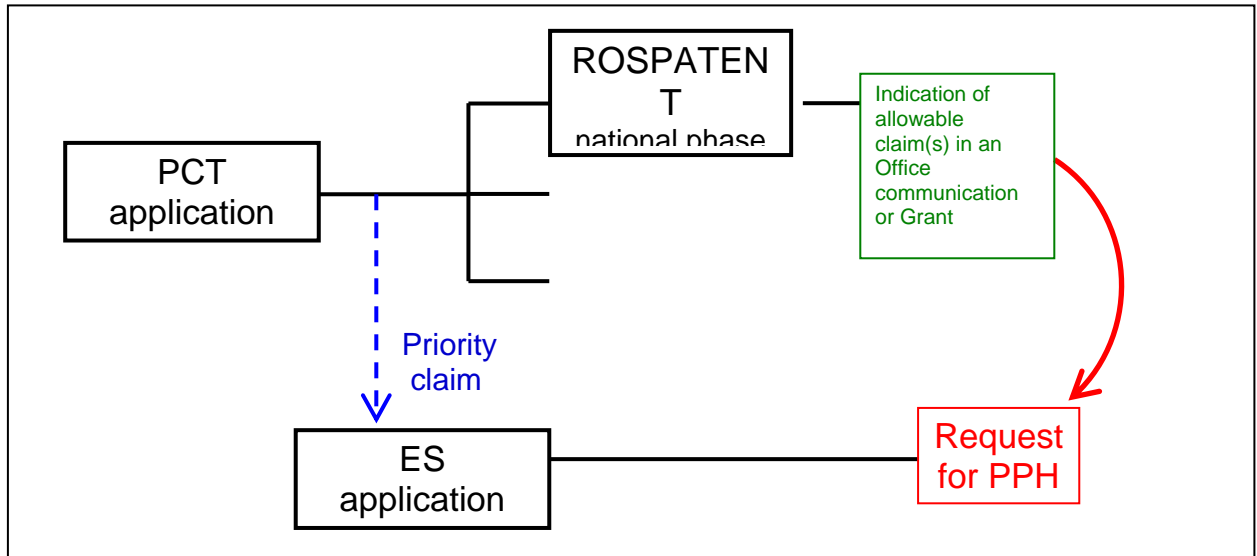

- ES application is a national stage of a PCT application which claims Paris Convention priority to an ROSPATENT application

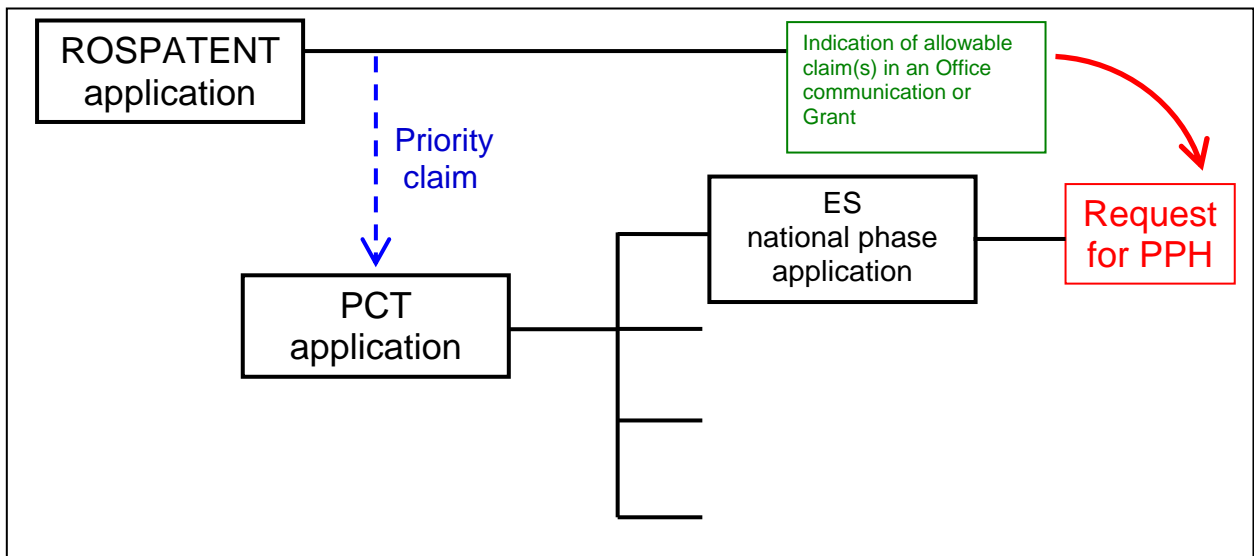

- PCT Route

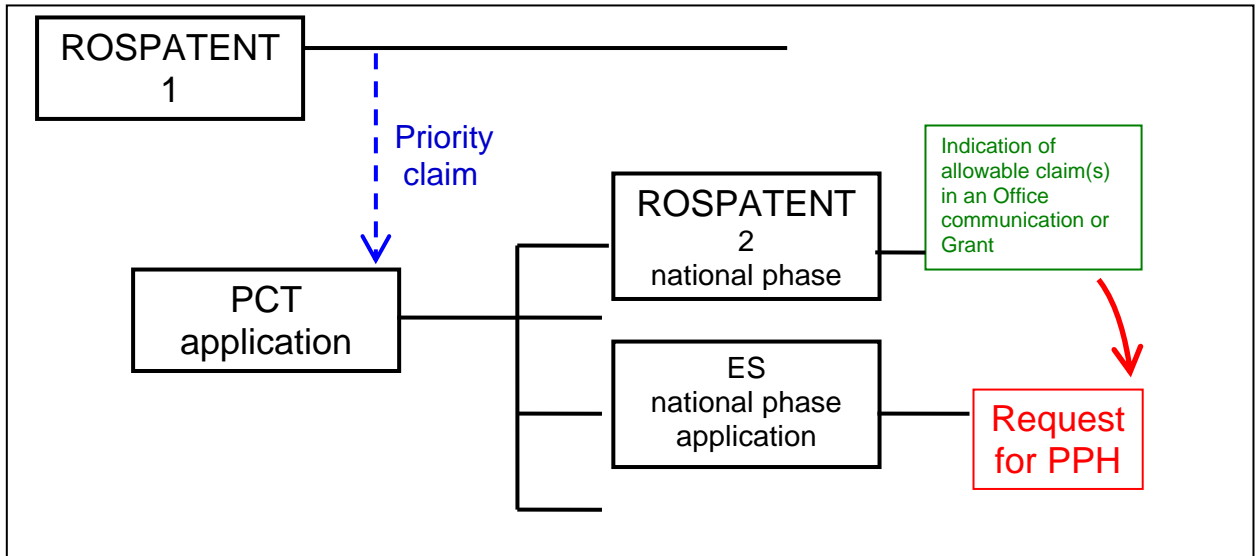

- ES application is a national stage of a PCT application which claims Paris Convention priority to another PCT application

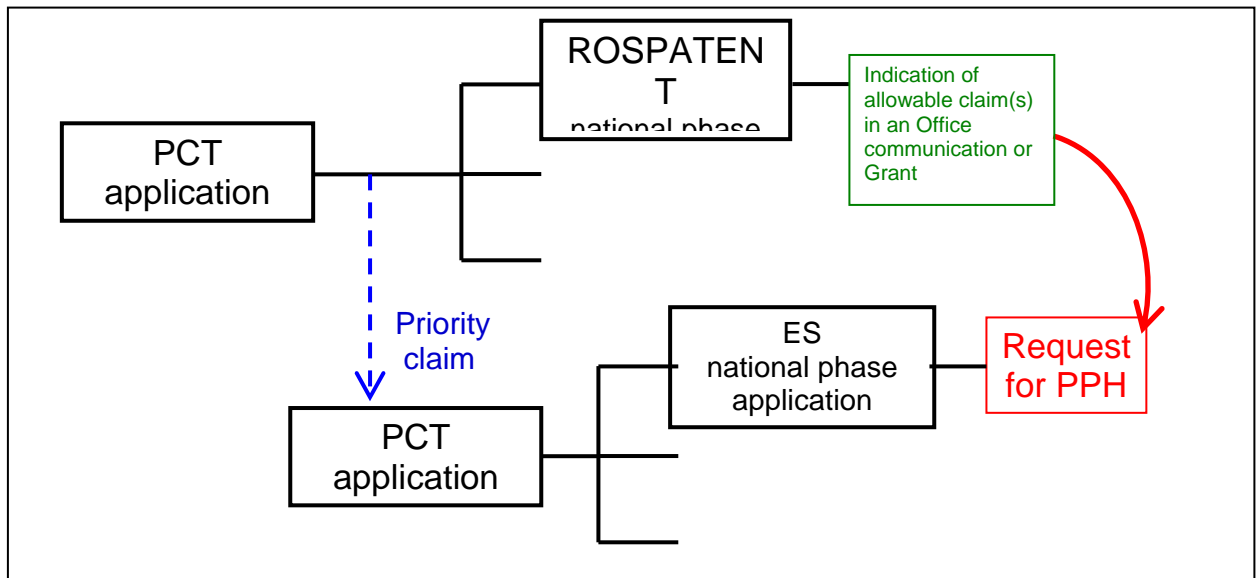

- Direct PCT and PCT Route

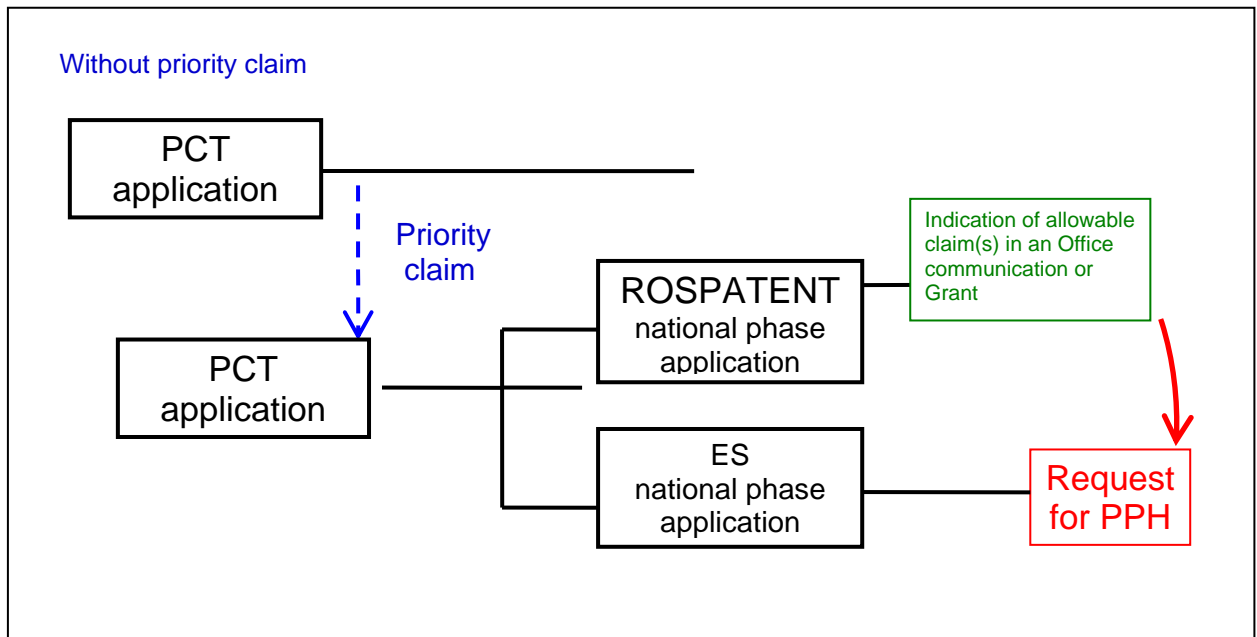

- ES application is a national stage of a PCT application without priority claim

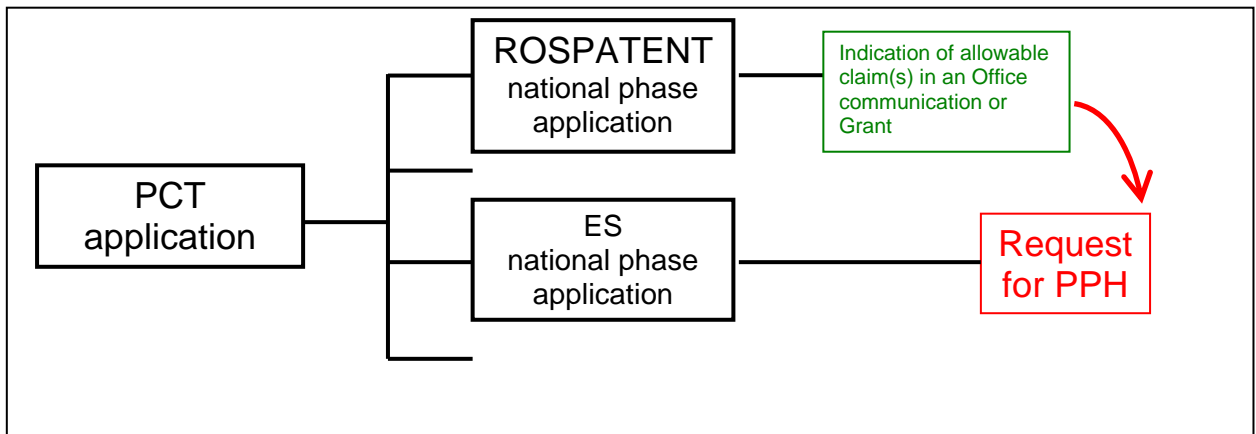

ANNEX 2

(A) The application is a national phase application of the corresponding international application.

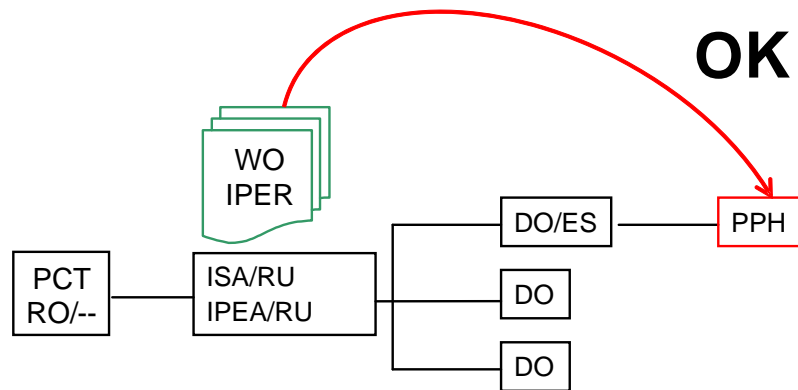

(A') The application is a national phase application of the corresponding international application (The corresponding international application claims priority from a national application.)

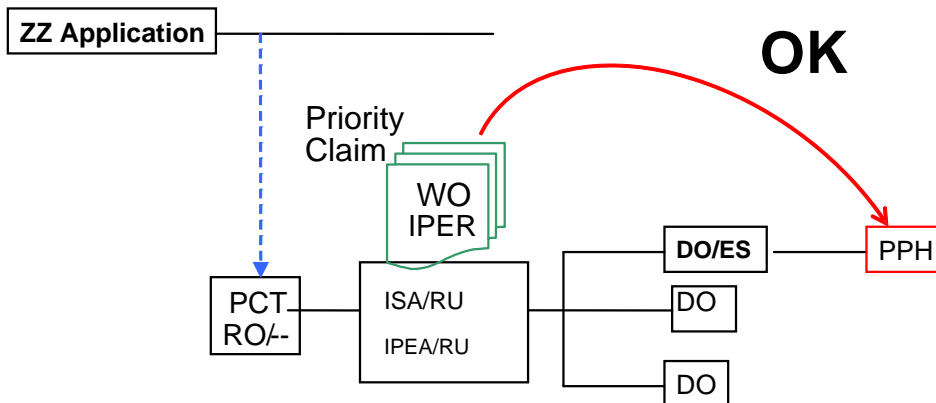

ZZ=any office

(A'') The application is a national phase application of the corresponding international application
 (The corresponding international application claims priority from an international application.)

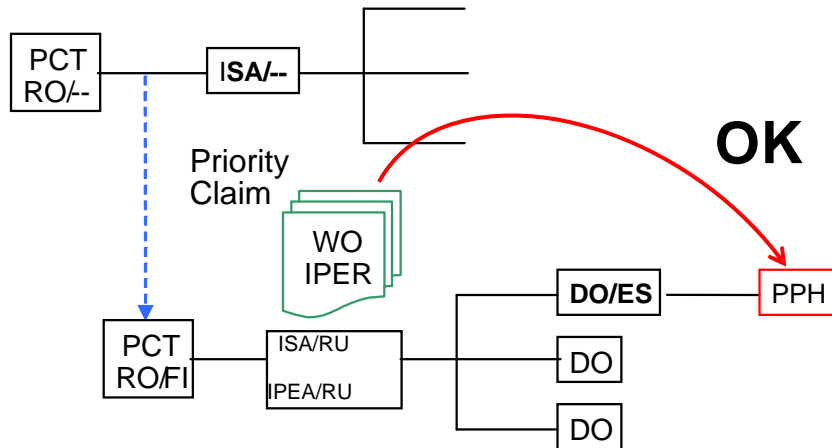

(B) The application is a national application as a basis of the priority claim of the corresponding international application.

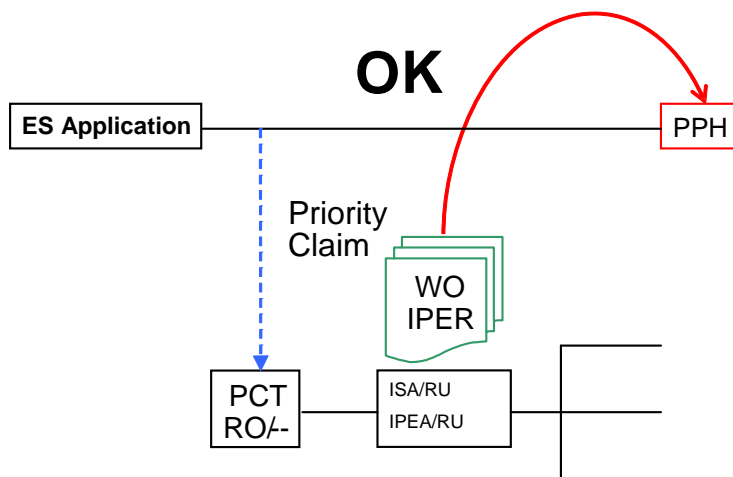

(C) The application is a national phase application of an international application claiming priority from the corresponding international application.

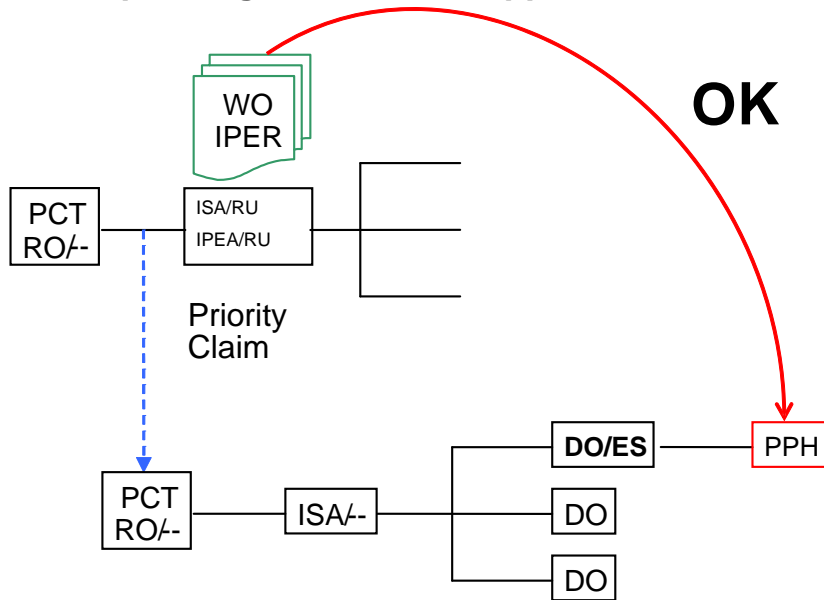

(D) The application is a national application claiming priority from the corresponding international application.

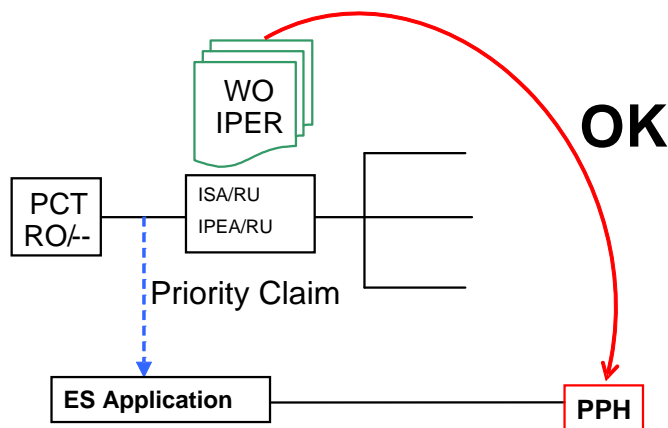

(E) The application is a divisional application of an application which satisfies the requirement (A).

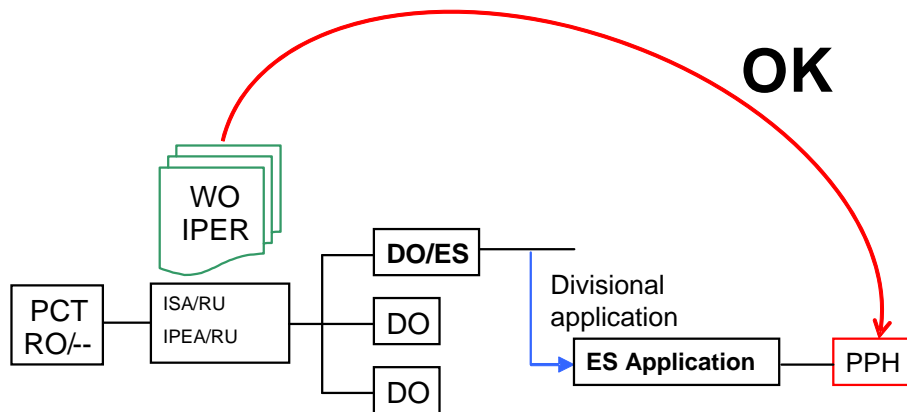

ANNEX 3

PPH REQUEST

Request for Accelerated Examination at the Spanish Patent and Trademark Office (SPTO) under the Patent Prosecution Highway Pilot Program . PPH using national work products.

Application information

SPTO application number:

Office of First Filing (hereinafter OFF):

JPO USPTO CIPO ROSPATENT

Corresponding OFF application or publication number(s):

Relevant supporting documents

List of Required Documents. Please, tick the boxes below:

1. Either:

1.1. A copy of all the office actions (which are relevant to the patentability) in the above-identified OFF application(s) is attached.

or

1.2. SPTO to obtain the office actions from the OFF database, where there exists such a data base.

2. Either:

2.1. A copy of all claims which were determined to be patentable/allowable by the OFF in the above-identified OFF application(s) is attached.

or

2.2. SPTO to obtain the set of patentable/allowable claims from the OFF data base, where there exists such a data base.

3. Either:

3.1. Translations into Spanish or English of the documents in 1 and 2 are attached.

or

3.2. SPTO to obtain the translations from the OFF database, where there exists such a data base.

4. Copies of the documents referred by the OFF Examiner are attached. Patent literature is not necessary to be submitted. Non-patent literature must always be submitted.

5. Incorporation by reference. If you want to incorporate any of the above mentioned documents please provide now all the necessary data:

.....
.....
.....

Claim correspondence table completed

Claim correspondence table

SPTO claims	Corresponding OFF claims	Comments explaining the correspondence

The applicant does request, if applicable to the circumstances of the present case, the early publication of the patent application according to Article 32(3) Spanish Patent Law.

ANNEX 4

PPH-PCT REQUEST

Request for Accelerated Examination at the Spanish Patent and Trademark Office (SPTO) under the Patent Prosecution Highway-PCT Pilot Program. PPH using the PCT international work products.

Application information

The corresponding PCT application number(s) is/are:

The international date of the corresponding PCT application number(s) is/are:

PPH request for using the PCT international work products from:

JPO USPTO ROSPATENT

Relevant supporting documents

List of Required Documents. Please, tick the boxes below:

1. Either:

1.1. A copy of the latest international work product (WO/ISA, WO/IPEA or IPER) in the above-identified PCT application(s) is attached.

or

1.2. SPTO to obtain that document from 'PATENTSCOPE®'.

2. Either:

2.1. A copy of all claims which were determined to be patentable/allowable in the above-identified PCT application(s) is attached.

or

2.2. SPTO to obtain the set of patentable/allowable claims 'PATENTSCOPE®'.

3. Either:

3.1. Translations into Spanish or English of the document in item 1 are attached.

or

3.2. SPTO to obtain the translations from PATENTSCOPE®.

4. Either:

4.1. Translations into Spanish or English of the document in item 2 are attached.

or

4.2. SPTO to obtain the translations from PATENTSCOPE®.

5. Copies of the documents cited in the international work products (ISR, WO/ISA, WO/IPEA or IPER) of the corresponding PCT application are attached. Patent literature is not necessary to be submitted. Non-patent literature must always be submitted.

6. Incorporation by reference. If you want to incorporate any of the above mentioned documents please provide now all the necessary data:

.....

.....

.....

.....

.....

Claim correspondence table completed

