



Procedures to file a request to the Austrian Patent Office (APO) for Patent Prosecution Highway (PPH) Pilot Program between the APO and the United States Patent and Trademark Office (USPTO)



PART 1: PPH using the national work products from the Office of First Filing (OFF)

The PPH Pilot Program enables an application whose claims have been determined to be patentable in the Office of First Filing (OFF) - USPTO - to undergo an accelerated examination in the Office of Second Filing (OSF) - APO - with a simple procedure according to a request from an applicant.

1. Request to the APO

An applicant has to file a request for accelerated examination under the PPH to the APO by submitting a bilingual German/English form for requesting accelerated examination under the PPH Pilot Program accompanied by the relevant supporting documents. The requirements for an application to the APO for accelerated examination under the PPH are given in paragraph 2. Relevant supporting documentation (paragraph 3) and the general AT application procedure envisaged at this time is discussed in the following section (paragraph 4).

2. Requirements for requesting accelerated examination under the PPH Pilot Program at the APO

There are four requirements for requesting accelerated examination under the PPH Pilot Program at the APO. These are:

a) **The AT application (including PCT national phase applications) is:**

- (i) an application which validly claims priority under the Paris Convention to the US application(s) (examples are provided in Annex 1, figure A, B, H, I, J and K), or
- (ii) a PCT national phase application without priority claim (direct PCT applications) (examples are provided in Annex 1, figure L), or
- (iii) an application which validly claims priority under the Paris Convention to the PCT application(s) without priority claim (examples are provided in Annex 1, figure M, N and O).

An AT application which validly claims priority to multiple US or PCT applications, or which is a divisional application validly based on the originally filed application that is included in (i) to (iii) above, is also eligible.

b) **At least one corresponding US application has one or more claims that have been determined to be patentable by the USPTO.**

c) **All claims in the AT application for accelerated examination under the PPH must sufficiently correspond to one or more of those claims indicated as patentable in the USPTO.**

Claims shall be considered to sufficiently correspond where the claims are of the same scope such that the claims in the AT application have a common technical feature with the claims in the US application which makes the claims allowable over the prior art in the corresponding US application. Where amended claims have been determined to be patentable by the USPTO, the claims of the AT application should be such that they correspond to the amended claims of the US application. Claims of the AT application which are appended to earlier claims of the AT application corresponding to claims that are indicated as patentable by the

USPTO will also be considered where such claims fall within the scope of the claims indicated as patentable by the USPTO.

- d) **The APO has not yet issued a decision to grant a patent ('Erteilungsbeschluss').**

3. Required documents for accelerated examination under the PPH Pilot Program at the APO

The following documentation will be needed to support a request for accelerated examination under the PPH Pilot Program at the APO:

- a) **a copy of all office actions on the corresponding US application(s).**
Copies of USPTO office actions in English language are accepted and need not, as a rule, be translated into German. No copy of the office actions need be supplied if the office actions are available via the website of the USPTO. Should the office actions in English language not be comprehensible to the APO examiner, he may request an additional translation into German from the applicant.
- b) **a copy of the claims examined by the USPTO and copies of subsequent amended claims found to be patentable by the USPTO where appropriate.**
The Copies of the claims determined to be allowable/patentable in the USPTO might be either copies of the amendments, the document submitted at filing which includes claims determined to be allowable/patentable, or a copy of the USPTO's publication of the granted patent. No paper copy of the claims need be supplied if the claims are available via the website of the USPTO. Should the claims in English language not be comprehensible to the APO examiner, he may request an additional translation into German from the applicant.
- c) **a completed claim correspondence table in German or English language showing the correspondence between the claims of the AT application for accelerated examination under the PPH and the claims of the corresponding US application considered patentable by the USPTO.**
Sufficient correspondence of claims occurs where the claims are of the same scope as defined above. When claims are just literal translation, the applicant can just write down that 'they are same' in the table. When claims are not just literal translation, it is necessary to explain the sufficient correspondence of each claim based on the criteria 2c).
- d) **a copy of the document(s) cited by the USPTO examiner in the reasons for refusal.**
If the cited document is a patent document, it does not have to be submitted as it is generally available to the APO via EPOQUE. Only if the APO has difficulty in obtaining a patent document the Office will ask the applicant to submit it.
As a rule, cited documents need not be translated.

The applicant has to provide the relevant information by filling in a form for requesting accelerated examination under the PPH Pilot Program which is available for download from the APO website. The form should be sent to the APO along with the relevant supporting documentation.

If the applicant has already submitted the above documents 3a) to 3d) to the APO through simultaneous or past procedures, the applicant can incorporate the documents by reference and does not have to attach them.

4. Procedure for accelerated examination under the PPH Pilot Program at the APO

The applicant files a form requesting accelerated examination under the PPH Pilot Program to the APO, including the relevant supporting documents. If the requirements are met, the APO will conduct the accelerated examination. If the application does not qualify for participation in the PPH Pilot Project, the applicant will be informed accordingly and the application will be further processed under the standard APO examination procedure, without acceleration.

PART 2: PPH using the PCT international work products (PCT- PPH)

Under the PCT- PPH Pilot Program a PCT- PPH request can be based on the latest PCT work product (“Written Opinion of International Searching Authority (WO/ISA)”, “Written Opinion of International Preliminary Examining Authority (WO/IPEA)” or “International Preliminary Examination Report (IPER)”) established by the USPTO as ISA or IPEA, where this work product determines claims to be patentable/allowable.

1. Request to the APO

An applicant has to file a request for accelerated examination under the PCT- PPH to the APO by submitting a bilingual German/English form for requesting accelerated examination under the PCT- PPH Pilot Program accompanied by the relevant supporting documents. The requirements for an application to the APO for accelerated examination under the PCT- PPH are given in paragraph 2. Relevant supporting documentation (paragraph 3) and the general AT application procedure envisaged at this time is discussed in the following section (paragraph 4).

2. Requirements for requesting accelerated examination under the PCT- PPH Pilot Program at the APO

There are four requirements for requesting accelerated examination under the PCT- PPH Pilot Program at the APO. These are:

- a) **The relationship between the AT application and the corresponding international application satisfies one of the following requirements** (including the case that the Office of the application is the same as the ISA/IPEA of the corresponding international application):
 - i) The application is a national phase application of the corresponding international application (examples are provided in Annex 2, figure A, A' and A'').
 - ii) The application is a national application as a basis of the priority claim of the corresponding international application (example is provided in Annex 2, figure B).
 - iii) The application is a national phase application of an international application claiming priority from the corresponding international application (example is provided in Annex 2, figure C).
 - iv) The application is a national application claiming foreign/domestic priority from the corresponding international application (example is provided in Annex 2, figure D).
 - v) The application is the derivative application (divisional application, application claiming internal priority, etc.) of the application which satisfies one of the above requirements (i) – (iv) (examples are provided in Annex 2, figures E1 and E2).
- b) **The AT application has one or more claim(s) that are determined to be patentable/allowable in the work product of the corresponding PCT application.**

The latest work product in the international phase of a PCT application corresponding to the application (“international work product”), namely the “Written Opinion of International Searching Authority (WO/ISA)”, the “Written Opinion of International Preliminary Examining Authority (WO/IPEA)” or the “International Preliminary Examination Report (IPER)”, indicates at least one claim as patentable/allowable (from the aspect of novelty, inventive steps and industrial applicability). The applicant cannot file a request under PCT- PPH on the basis of an International Search Report (ISR) only.

In case any observation is described in Box VIII of WO/ISA, WO/IPEA or IPER which forms the basis of a PCT- PPH request, the applicant must explain why the claim(s) is/are not subject to the observation whether or not an amendment is submitted to correct the observation.

- c) **All claims on file, as originally filed or as amended, for examination under the PCT- PPH must sufficiently correspond to one or more of those claims indicated as patentable/allowable in the latest international work product of the corresponding international application.**

Claims shall be considered to sufficiently correspond where the claims are of the same scope such that the claims in the AT application have a common technical feature with the claims in the PCT application which makes the claims allowable over the prior art in the corresponding PCT application. Where amended claims have been determined to be patentable, the claims of the AT application should be such that they correspond to the amended claims of the PCT application. Claims of the AT application which are appended to earlier claims of the AT application corresponding to claims that are indicated as patentable will also be considered where such claims fall within the scope of the claims indicated as patentable.

- d) **The APO has not yet issued a decision to grant a patent ('Erteilungsbeschluss').**

3. Required documents for accelerated examination under the PCT- PPH Pilot Program at the APO

The following documentation will be needed to support a request for accelerated examination under the PCT- PPH Pilot Program at the APO:

- a) **a copy of the latest international work product of the corresponding international application**

A copy in English language is accepted and need not, as a rule, be translated into German. If the copy of the latest international work product is available via "PATENTSCOPE"¹, an applicant need not submit these documents, unless otherwise requested by the APO (WO/ISA and IPRP are usually available as "IPRP Chapter I" and "IPRP Chapter II" respectively in 30 months after the priority date). Should the copy in English language not be comprehensible to the APO examiner, he may request an additional translation into German from the applicant.

- b) **a copy of a set of claims which the latest international work product of the corresponding international application indicated as patentable/allowable**

A copy in English language is accepted and need not, as a rule, be translated into German. If the copy of the set of claims which are indicated as patentable/allowable is available via "PATENTSCOPE", an applicant need not submit this document, unless otherwise requested by the APO. Where translations of the patentable/allowable claims are necessary, they must be submitted by an applicant since "PATENTSCOPE" does not provide them.

- c) **a completed claim correspondence table in German or English language showing the correspondence between the claims of the AT application and the claims determined to be patentable/allowable in the latest work product of the corresponding international application**

Sufficient correspondence of claims occurs where the claims are of the same scope as defined above. When claims are just literal translation, the applicant can just write down that 'they are same' in the table. When claims are not just literal translation, it is necessary to explain the sufficient correspondence of each claim based on the criteria 2c).

- d) **copies of references cited in the latest international work product of the corresponding international application**

If the references are patent documents, the applicant doesn't have to submit them because the office of the application usually possesses them. When the office of the application does not possess the patent document, the applicant has to submit the patent document at the examiner's request. Non-patent literature must always be submitted.

The applicant has to provide the relevant information by filling in a form for requesting accelerated examination under the PCT- PPH Pilot Program which is available for download from the APO website. The form should be sent to the APO along with the relevant supporting documentation.

If the applicant has already submitted the above documents 3a) to 3d) to the APO through simultaneous or past procedures, the applicant can incorporate the documents by reference and does not have to attach them.

¹ <http://www.wipo.int/pctdb/en/index.jsp>

4. Procedure for accelerated examination under the PCT- PPH Pilot Program at the APO

The applicant files a form requesting accelerated examination under the PCT- PPH Pilot Program to the APO, including the relevant supporting documents. If the requirements are met, the APO will conduct the accelerated examination. If the application does not qualify for participation in the PCT- PPH Pilot Project, the applicant will be informed accordingly and the application will be further processed under the standard APO examination procedure, without acceleration.

A A case meeting requirement (a) (i)
- Paris route -

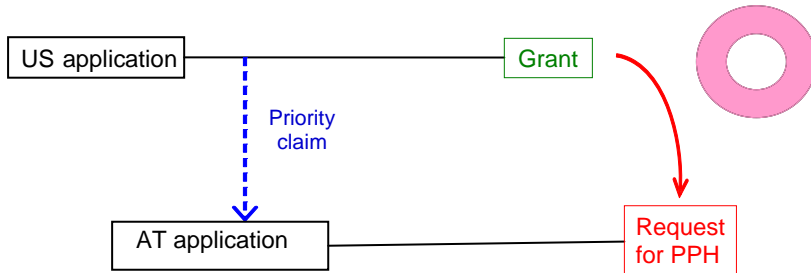

B A case meeting requirement (a) (i)
- PCT route -

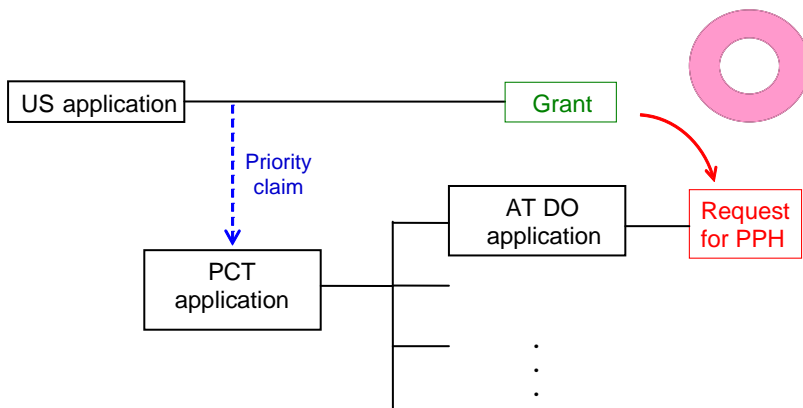

C

A case not meeting requirement (a)

- Paris route, but the first application is from the third country -

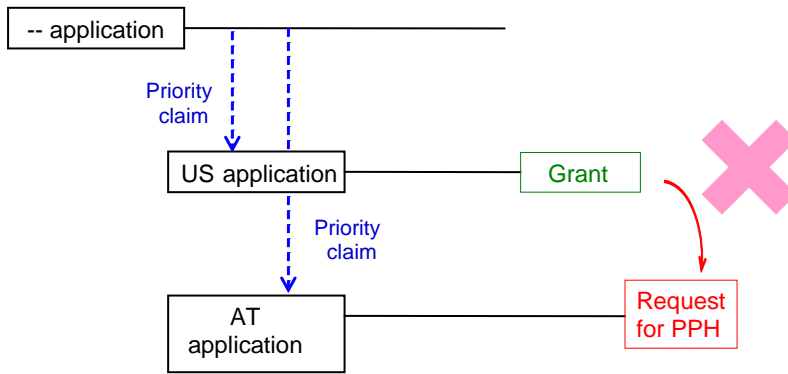

--: NOT PPH participating country

D

A case not meeting requirement (a)

- PCT route, but the first application is from the third country -

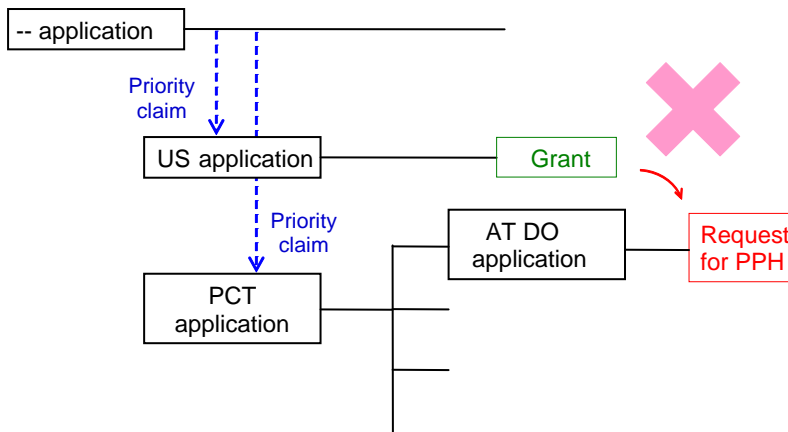

--: NOT PPH participating country

G

A case not meeting requirement (d)

- "Decision to grant a patent" has issued before a request for PPH -

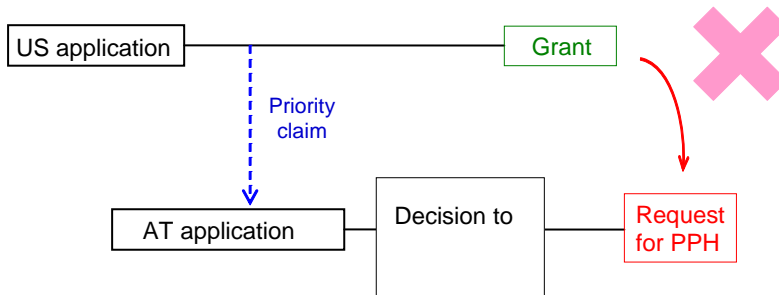

H

A case meeting requirement (a) (i)

- Paris route & Complex priority -

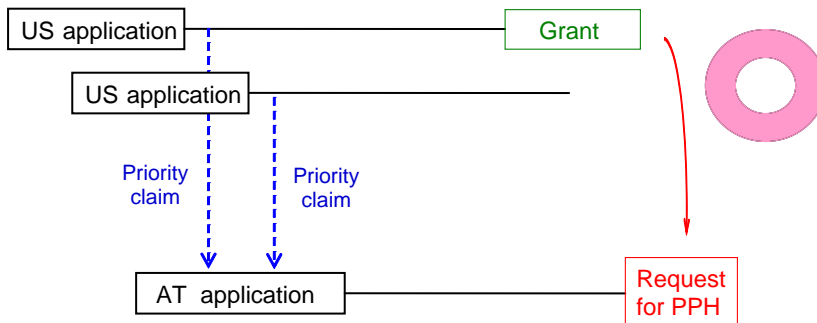

I

A case meeting requirement (a) (i)

- Paris route & Internal priority -

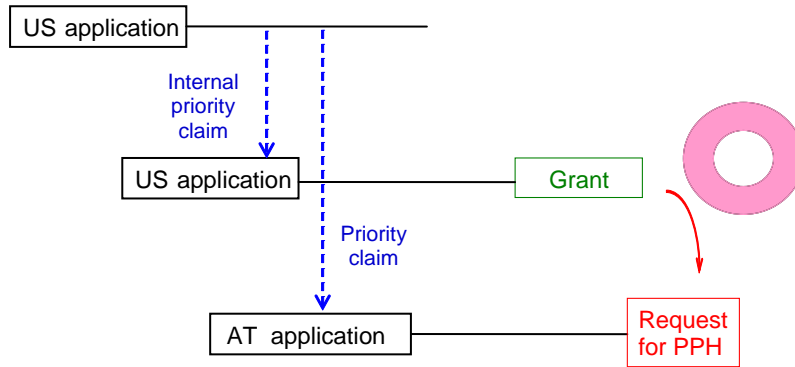

J

A case meeting requirement (a) (i)

- Paris route & divisional application -

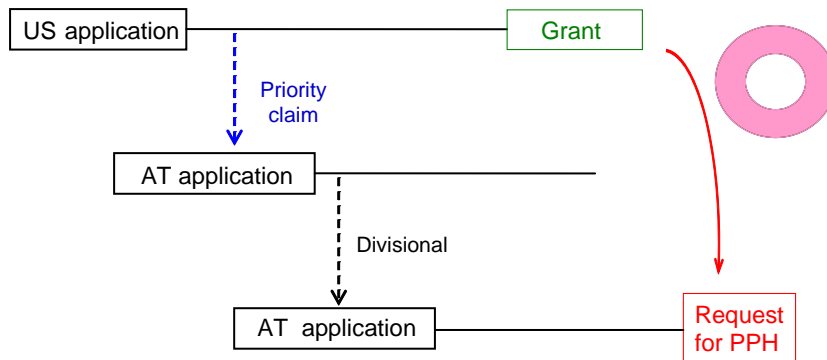

K

A case meeting requirement (a) (i)

- PCT route -

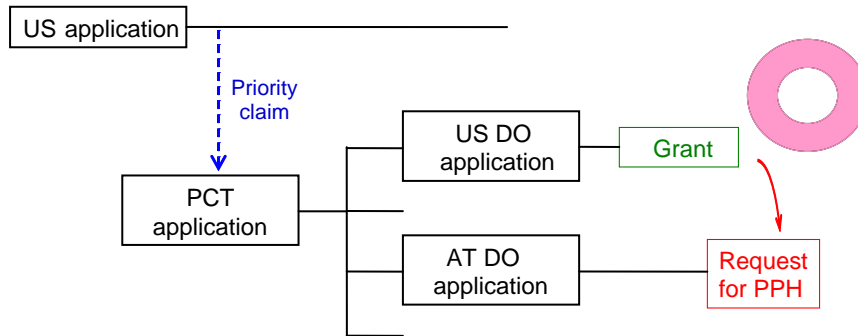

L

A case meeting requirement (a) (ii)

- Direct PCT route -

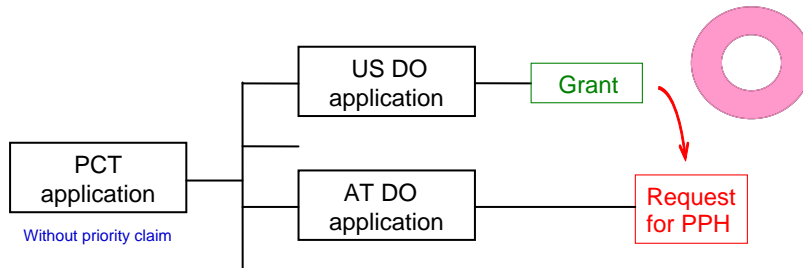

M

A case meeting requirement (a) (iii)

- Direct PCT & Paris route -

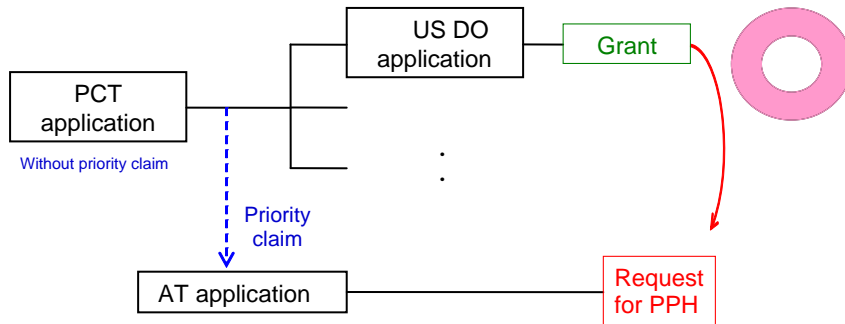

N

A case meeting requirement (a) (iii)

- Direct PCT & PCT route -

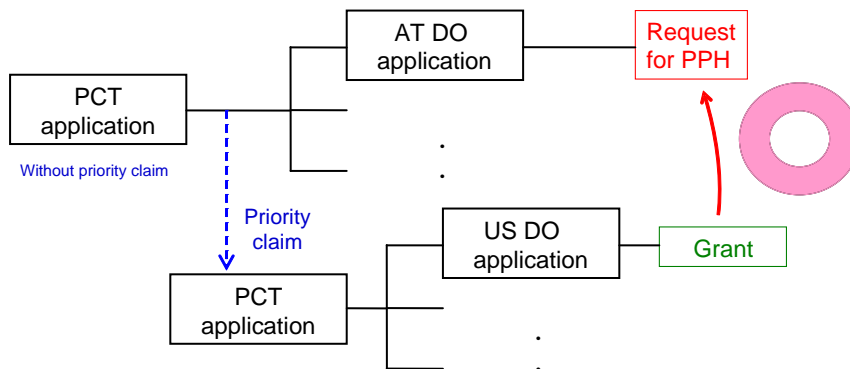

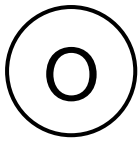

A case meeting requirement (a) (iii)

- Direct PCT & PCT route -

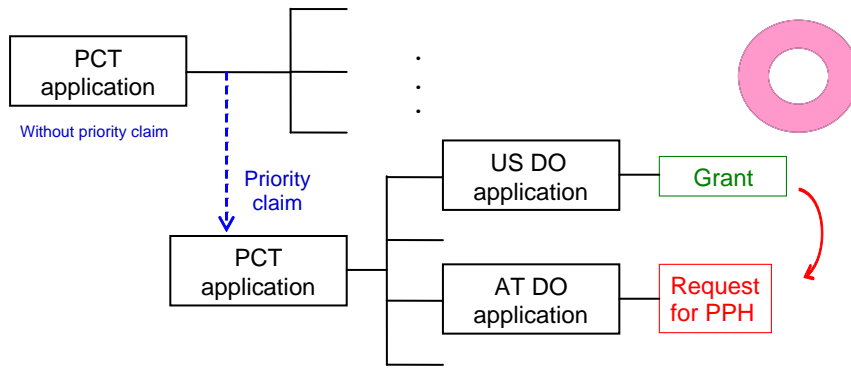

Eligible applications for PCT-PPH:

(A) The application is a national phase application of the corresponding international application.

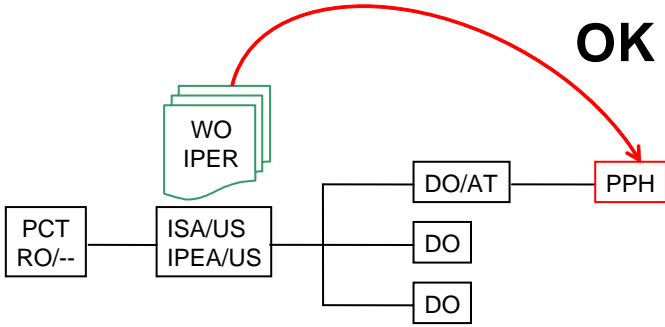

**(A') The application is a national phase application of the corresponding international application.
(The corresponding international application claims priority from a national application.)**

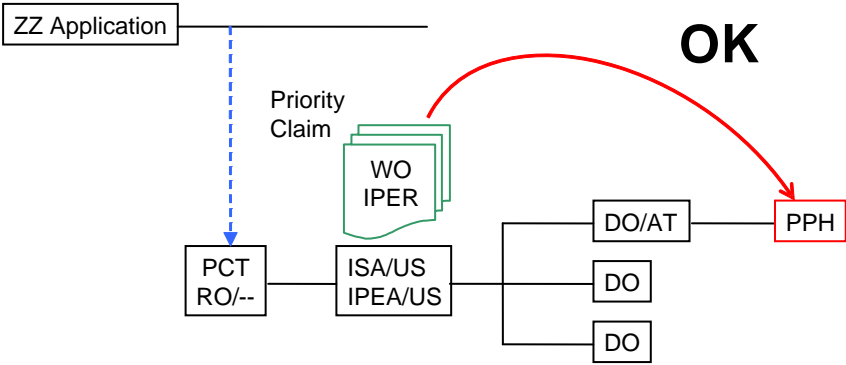

**(A'') The application is a national phase application of the corresponding international application.
 (The corresponding international application claims priority from an international application.)**

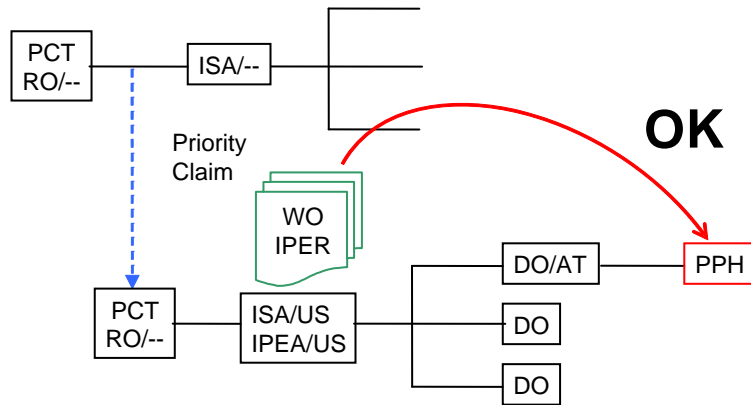

(B) The application is a national application as a basis of the priority claim of the corresponding international application.

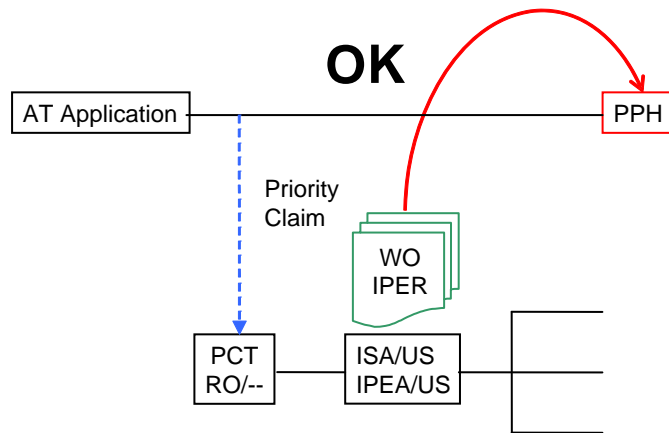

(C) The application is a national phase application of an international application claiming priority from the corresponding international application.

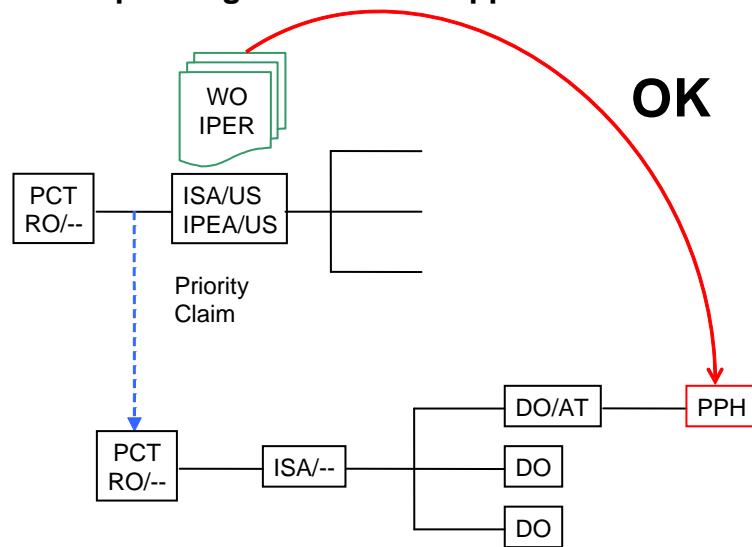

(D) The application is a national application claiming foreign/domestic priority from the corresponding international application.

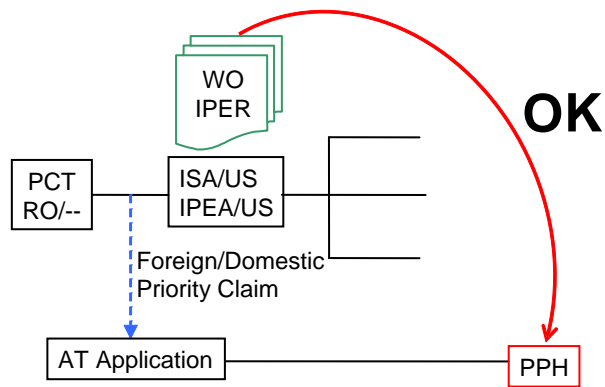

(E1) The application is a divisional application of an application which satisfies the requirement (A).

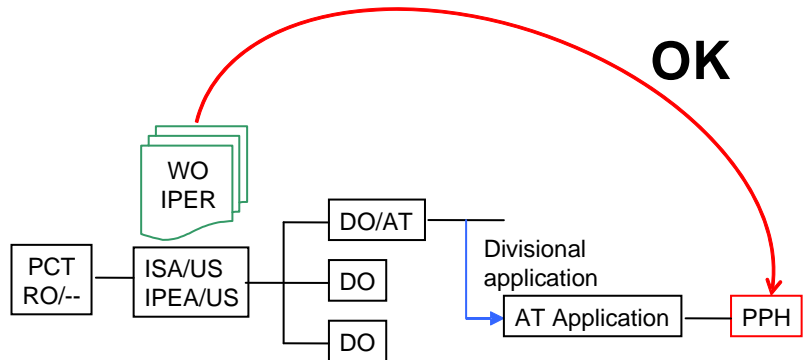

(E2) The application is an application claiming domestic priority from an application which satisfies the requirement (B).

