

DEUTSCHES PATENT- UND MARKENAMT

80297 München

Telephone: (49 - 89) 21 95 - 0

Telefax: (49 - 89) 21 95 - 22 21

Telephone enquiries: (49 - 89) 21 95 - 34 02

Internet: <http://www.dpma.de>

Beneficiary:

Bundeskasse Weiden

BBk München 700 010 54 (Bank sort code: 700 000 00)

BIC (SWIFT Code): MARKDEF1700

IBAN: DE84 7000 0000 0070 0010 54

- Dienststelle Jena -

07738 Jena

Telephone: (49 - 36 41) 40 - 54

Telefax: (49 - 36 41) 40 - 56 90

Telephone enquiries: (49 - 36 41) 40 - 55 55

- Technisches Informationszentrum Berlin -

10958 Berlin

Telephone: (49 - 30) 25 992 - 0

Telefax: (49 - 30) 25 992 - 404

Telephone enquiries: (49 - 30) 25 992 - 220

Procedures to file a request to the DPMA for Patent Prosecution Highway ("PPH") Pilot Program between the DPMA and the KIPO

1. The outline of the Patent Prosecution Highway Pilot Program

The PPH pilot program enables an application whose claims have been determined to be patentable in the Office of First Filing (OFF) to undergo an accelerated examination in the Office of Second Filing (OSF) with a simple procedure according to a request from an applicant.

2. Request to the DPMA as OSF

An applicant has to file a request for accelerated examination under the PPH to the DPMA as OSF in German language by submitting a request form for accelerated examination under the PPH pilot program accompanied by the relevant supporting documents. The requirements for a request for accelerated examination under the PPH at the DPMA are given in the following section (paragraph 3). Relevant supporting documentation is discussed in a later section (paragraph 4) as is the general DPMA application procedure envisaged at this time (paragraph 5).

3. Requirements for requesting accelerated examination under the PPH Pilot Program at the DPMA

There are four requirements for requesting accelerated examination under the PPH pilot program at the DPMA as OSF. These are:

a) **The DPMA application (including PCT national phase application in Germany) either:**

- i) validly claims priority under the Paris Convention from either a single corresponding KIPO application or multiple KIPO applications (examples are provided in Annex, figures A, B, G, H and J); or

- ii) is a PCT application in the national phase without Korean priority claim for which the national phase was initiated in Korea either without priority claim (an example is provided in Annex, figure K) or claiming priority from the prior PCT application (an example is provided in Annex, figure M); or
- iii) validly claims priority under the Paris Convention from a PCT application the national phase of which was initiated in Korea (an example is provided in Annex, figure L) or
- iv) is a PCT application in the national phase for which the national phase was initiated in Korea and the relevant PCT application for the national phase in Korea and Germany validly claims priority under the Paris Convention from a prior PCT application (an example is provided in Annex, figure N), or
- v) is a divisional application based on the originally filed application that is included in the above i), ii), iii) or iv).
- vi) is a patent application corresponding to a Korean utility model application which has been subject to substantive examination under the New Korean Utility Model Act after 1st October 2006.

- b) **At least one corresponding KIPO application has one or more claims that have been determined to be patentable by the KIPO.**
- c) **All claims in the DPMA application for accelerated examination under the PPH must sufficiently correspond to one or more of those claims indicated as patentable in the KIPO application.**

Claims shall be considered to sufficiently correspond where the claims are of the same scope. This means that the claims in the DPMA application have a common technical feature with the claims in the KIPO application which

makes the claims allowable over the prior art in the corresponding KIPO application.

Where amended claims have been determined to be patentable by the KIPO, the claims of the DPMA application should be such that they correspond to the amended claims of the KIPO application.

Claims of the DPMA application which are appended to earlier claims of the DPMA application corresponding to claims that are indicated as patentable by the KIPO will also be considered where such claims fall within the scope of the claims indicated as patentable by the KIPO.

d) **The DPMA has not begun substantive examination of the application yet.**

This means that DPMA as OSF has not noticed a first office action to the applicant yet after the request for examination.

4. Required documents for accelerated examination under the PPH Pilot Program at the DPMA

The following documentation will be needed to support a request for accelerated examination under the PPH pilot program at the DPMA:

a) **A copy of all office actions on the corresponding KIPO application(s) and translation thereof.**

Both, German and English are acceptable as translation languages.

No paper copy and corresponding translation of the office actions need be supplied if the office actions are available on K-PION¹. However, if the available (machine) translation is insufficient, the DPMA examiner may request an additional translation from the applicant.

b) **A copy of the claims examined by the KIPO and copies of subsequent amended claims found to be patentable by the KIPO where appropriate and translation of them.**

Both German and English are acceptable as translation languages.

No paper copy or translation of the claims need be supplied if the claims are available on K-PION. However, if the available (machine) translation is insufficient, the DPMA examiner may request an additional translation from the applicant.

c) **A completed claim correspondence table in German language showing the relationship between the claims of the DPMA application for accelerated examination under the PPH and the claims of the corresponding KIPO**

application considered patentable by the KIPO.

Sufficient correspondence of claims occurs where the claims are of the same scope as defined above in 3c).

When claims are just literal translation, the applicant can just write down that "they are same" in the table. When claims are not just literal translation, it is necessary to explain the sufficient correspondence of each claim based on the criteria above in 3c).

d) **A copy of the document(s) cited by the KIPO examiner**

If the cited document is a patent document it does not have to be submitted as it is generally available to the DPMA either via DEPATIS, EPOQUE or K-PION. Where the DPMA has difficulty in obtaining a patent document the Office will ask the applicant to submit it. As a rule, cited documents need not be translated.

The applicant has to provide the relevant information for accelerated examination under the PPH by completing a PPH request form which will be made available for download from the DPMA website. The form should be sent to the DPMA along with the relevant supporting documentation.

If the applicant has already submitted the above documents a) to d) to the DPMA through simultaneous or past procedures, the applicant can incorporate the documents by reference and does not have to attach them.

5. Procedure for accelerated examination under the PPH Pilot Program at the DPMA

The applicant files a request form for accelerated examination under the PPH pilot program to the DPMA, including the relevant supporting documents.

a) If the requirements are met, the DPMA will conduct the accelerated examination.

b) If the application does not qualify for participation in the PPH project, the applicant will be informed accordingly and the application will be further processed under the standard DPMA examination procedure, without acceleration.

¹ K-PION is the Korean patent information network accessible by various patent offices which provides KIPO's file wrapper information. Applicants do not have access to K-PION.

Annexes:

A A case meeting requirement (a) (i)
- Paris route -

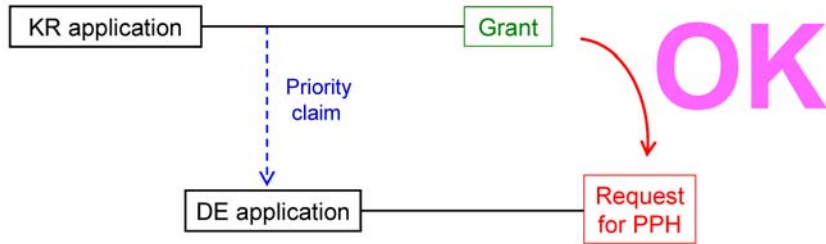

B A case meeting requirement (a) (i)
- PCT route -

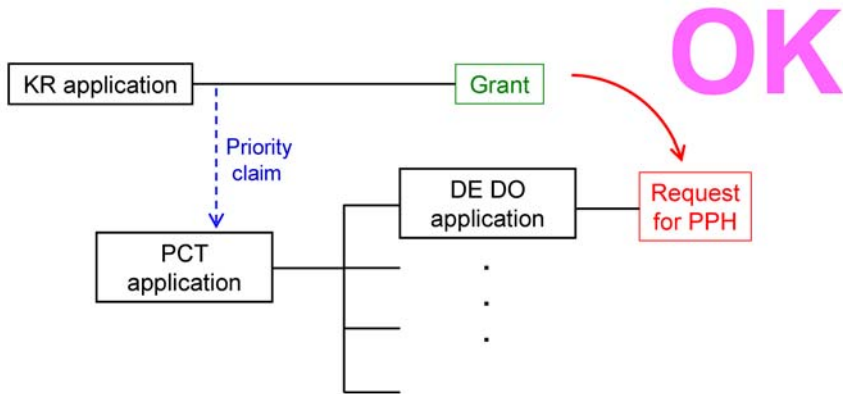

C A case not meeting requirement (a)
- Paris route, but the first application is from the third country -

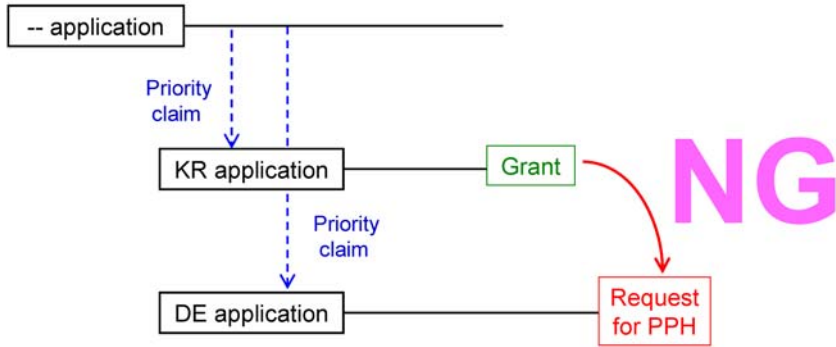

-- : the office other than the KIPO

D A case not meeting requirement (a)
- PCT route, but the first application is from the third country -

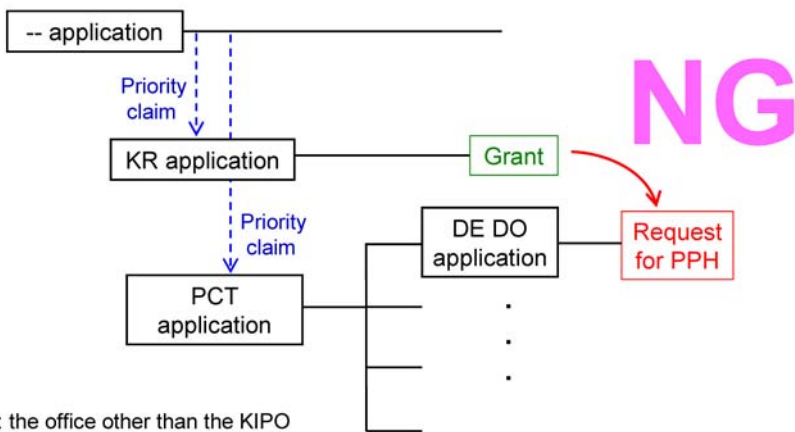

-- : the office other than the KIPO

E A case not meeting requirement (b)
- Search Report -

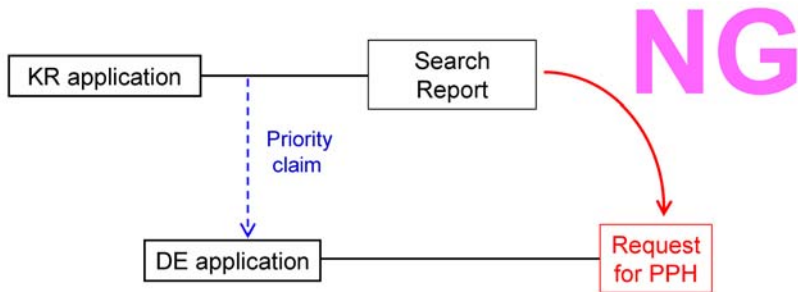

F A case not meeting requirement (b)
- ISR, ISO -

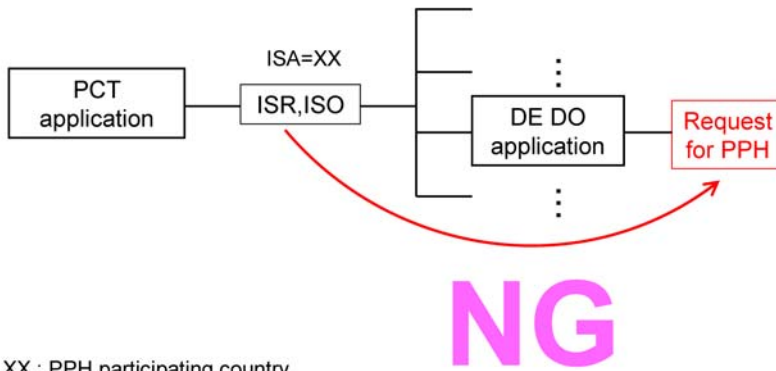

XX : PPH participating country

G A case meeting requirement (a) (i)
- Paris route & Complex priority -

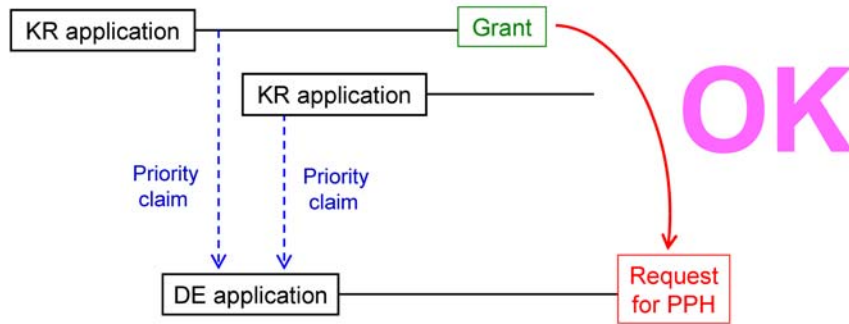

H A case meeting requirement (a) (i)
- Paris route & Internal priority -

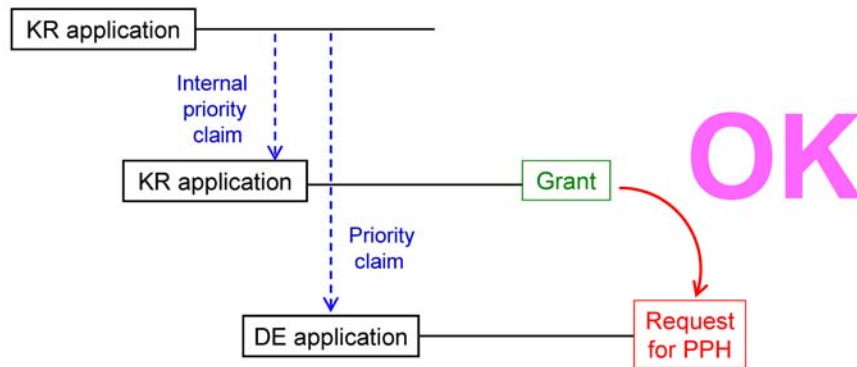

I A case meeting requirement (a) (i)
- Paris route & divisional application -

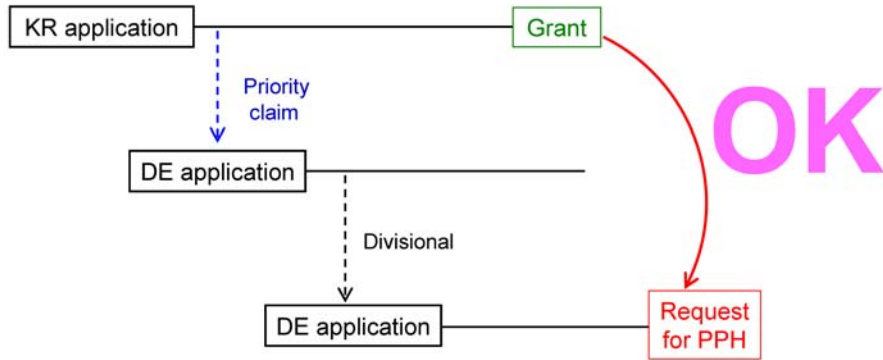

J A case meeting requirement (a) (i)
- PCT route -

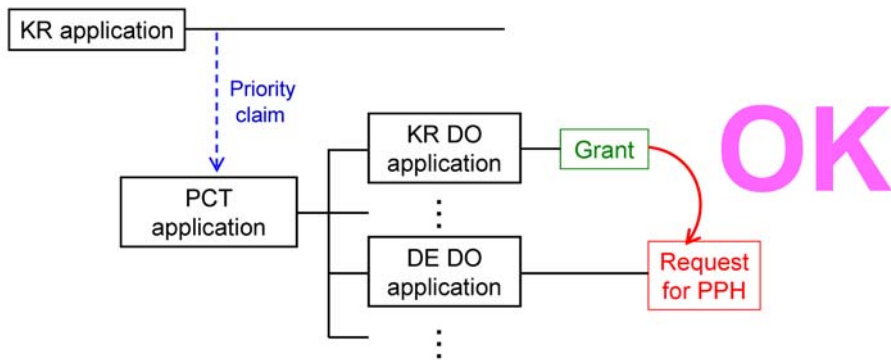

K A case meeting requirement (a) (ii)
- Direct PCT route -

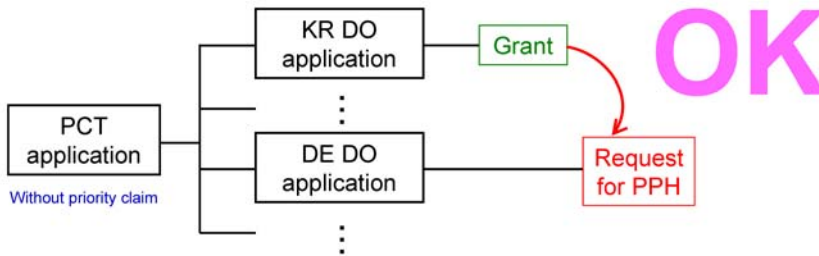

L A case meeting requirement (a) (iii)
- Direct PCT & Paris route -

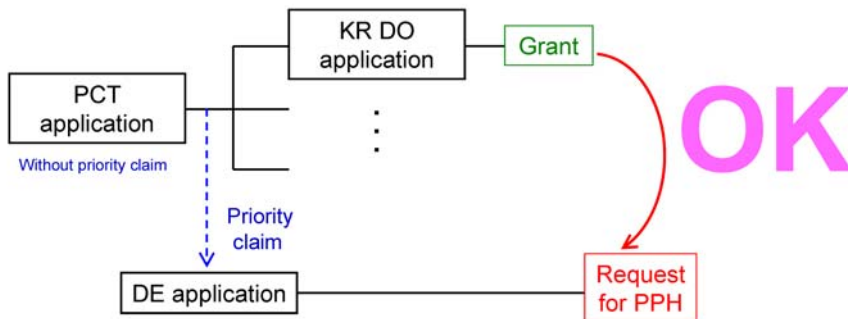

M A case meeting requirement (a) (ii)
- Direct PCT & PCT route -

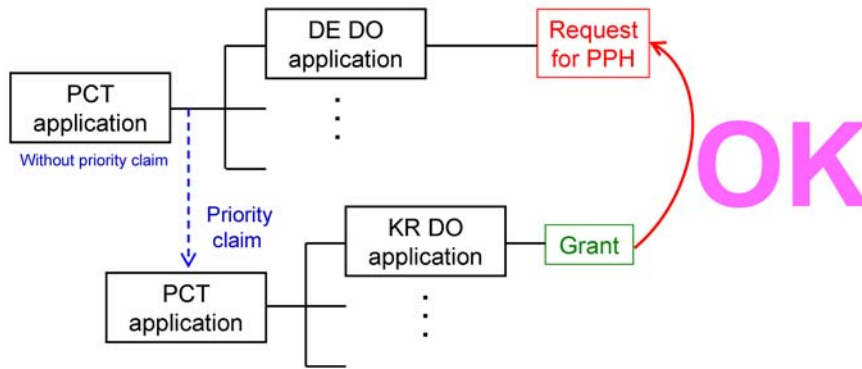

N A case meeting requirement (a) (iv)
- Direct PCT & PCT route -

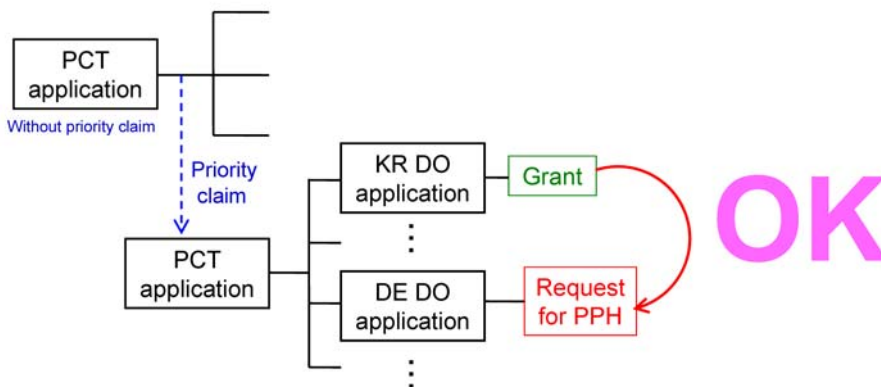

O A case not meeting requirement (d)
- Examination has begun before a request for PPH -

