



Procedures to File a Request to the Korean Intellectual Property Office for Patent Prosecution Highway Pilot Program between the Korean Intellectual Property Office and the German Patent and Trade Mark Office

I. Purpose of this document

This document aims to publicize the requirements and necessary documents for requesting participation in the Patent Prosecution Highway (PPH) pilot program between the Korean Intellectual Property Office (KIPO) and the German Patent and Trade Mark Office (DPMA) at the KIPO in order that an applicant is able to easily file a request for preferential examination under the PPH pilot program.

When an applicant files a request for preferential examination under the PPH pilot program to KIPO based on examination results by the DPMA, the PPH request should meet the requirements described in the below paragraph III.

II. Trial Period for the PPH Pilot Program

The PPH pilot program will commence on July 1, 2010, for a period of two years ending on June 30, 2012. The offices will evaluate the results of the pilot program to determine whether and how the program should be fully implemented after the trial period.

III. Procedures to File a Request for Preferential Examination under the PPH Pilot Program

1. Basic Requirements for Requesting Preferential Examination under the PPH Pilot Program at the KIPO

There are five requirements for requesting preferential examination under the PPH pilot program at KIPO. An applicant must fulfill all five requirements listed below:

1.1 The KIPO application (including a PCT national application) is either:

(1) a national application which validly claims priority under the Paris Convention from either a single national DPMA application or multiple national DPMA applications (examples are provided in Annex I, Figures A, B, C), or

(2) a PCT national phase application where the PCT international application has validly claimed priority from either a single DPMA national application or multiple national DPMA applications (examples are provided in Annex I, Figures D, E), or

(3) a PCT national phase application where the PCT application has no priority

claim (example is provided in Annex I, Figure F), or

(4) a national application that validly claims priority under the Paris Convention from either a single PCT application with no priority claim or multiple PCT applications with no priority claims (example is provided in Annex I, Figure G), or

(5) a PCT national phase application where the PCT application validly claims priority from a PCT application which has no priority claims (examples are provided in Annex I, Figures H, I), or

(6) a divisional application of an application as referred to in any of (1) to (5) (examples are provided in Annex I, Figure J).

Refer to Annex I for illustrated examples of the above applications.

[Note]

It is noted that the application is NOT eligible for the PPH pilot program in case where the examination was conducted in the EPO (not in DPMA) and the patent right was validated in DPMA as a designated state.

1.2 The corresponding application(s) in the DPMA has one or more claim(s) determined to be patentable/allowable by the DPMA

(1) The patentable/allowable claims of the DPMA are the claims which are explicitly identified as patentable/allowable in the granted patent publication or in the office action by the DPMA

(2) Corresponding application in the DPMA whose claims are determined to be patentable/allowable does not have to be the application for which priority is claimed in

the KIPO application (the basic application). The DPMA application can be an application explicitly derived from the basic application, e.g., a divisional application of the basic application, a converted application of the basic application or an application which claims domestic priority to the basic application (Refer to Example C and J in Annex I).

[Note]

Where the DPMA application that contains the patentable/allowable claims is not the same application for which priority is claimed in the KIPO application, applicant must identify the relationship between the DPMA application that contains the patentable/allowable claims and the DPMA priority application claimed in the KIPO application.

1.3 All claims in the KIPO must sufficiently correspond or be amended to sufficiently correspond to one or more of those claims determined to be patentable/allowable in the DPMA.

(1) Claims are considered to “sufficiently correspond” where the claims in the KIPO are the same or substantially same as the claims in the DPMA, or have additions or further limitations of specific features resulting that the claims in the KIPO fall within the scope of the claims in the DPMA.

A claim in the KIPO which introduces a new/different category of claims to those claims indicated as allowable in the DPMA is NOT considered to sufficiently correspond. For example, the DPMA claims only contain claims to a process of manufacturing a product, then the claims in the KIPO are not considered to sufficiently correspond if the

KIPO claims introduce product claims that are dependent on the corresponding process claims.

(2) It is not necessary to include “all” claims determined to be patentable/allowable in the DPMA in an application in the KIPO (the deletion of claims is allowable). For example, in the case where an application in the DPMA contains 5 claims determined to be patentable/allowable, the corresponding application in the KIPO may contain only 3 of these 5 claims.

Refer to Annex II for the cases which are considered to “sufficiently correspond” and the cases which are not considered to “sufficiently correspond”.

1.4 Whether examination of the KIPO application has begun or not, it is possible to participate in the PPH program

It is possible to participate in the PPH not only when examination has not begun, but also when examination has already begun.

1.5 A “Request for examination” must have been filed by the applicant in order to request the preferential examination under the PPH.

The request for preferential examination under the PPH must also be accompanied by, or preceded by a request for examination.

2. Document Necessary to File a Request for Preferential Examination under the PPH Pilot Program at the KIPO.

Applicant must submit a “Request Form

for Preferential Examination” and “The Explanation of Circumstances Concerning Preferential Examination under the PPH.” The documents 2.1 to 2.4 below must be submitted by attaching them to “The Explanation of Circumstances Concerning Preferential Examination under the PPH.” Please refer to the ANNEX III for “The Explanation of Circumstances Concerning Preferential Examination under the PPH.”

2.1 A Copy and translation of all claims determined to be patentable/allowable by the DPMA

(1) An applicant who requests participation in the PPH is required to submit the copy of the claims determined to be patentable/allowable in the DPMA.

The copy of the claims determined to be patentable/allowable by the DPMA might be either:

i) a copy of the document submitted at initial filing which includes claims determined to be patentable/allowable where no later amendments to the claims have been made, or

ii) a copy of the amendments which includes claims determined to be patentable/allowable where later amendments to the claims have been made, or

iii) a copy of the DPMA’s publication of the granted patent.

(2) Korean or English is acceptable as a translation language. If it is impossible for the examiner to understand the translated claims due to inadequate translation, the examiner can request the applicant to resubmit translations. It is noted that a request for the PPH is not rejected on the basis that the translation is not sufficient to understand the scope of the claims.

2.2 Copies and translation of all office actions in the DPMA

(1) An applicant who requests participation in the PPH is required to submit copies of the office actions in the DPMA.

“Office action” means documents which relate to examination and which were sent to an applicant from the DPMA examiner.

The office actions in the DPMA are:

- communications of the examiner (=Pruefungsbescheide). Please note that if claims are not deemed patentable in the communications of the examiner and are amended afterwards, the final decision to grant a patent (= Erteilungsbeschluss) has to be provided; or
- an isolated search report (=isolierter Recherchebericht) followed by the final decision to grant a patent .

(2) Korean or English is acceptable as a translation language. If it is impossible for the examiner to understand the translated office actions due to inadequate translation, the examiner can request the applicant to resubmit translations. It is noted that a request for the PPH is not rejected on the basis that the translation is not sufficient to understand the scope of the office actions.

2.3 Documents cited by the DPMA examiner

(1) The documents to be submitted are those cited in the office action in the reason of refusal in the DPMA. Documents which are only referred to as references and consequently do not take part of the reason for refusal do not have to be submitted.

(2) If the cited document is a patent document, applicant does not have to submit it because it is usually available to

the KIPO. However, if the cited document is non-patent literature, applicant will have to submit it.

[Note]

In the case where the KIPO examiner has difficulty in obtaining the document, it will ask the applicant to submit it. In every case, translations of the cited documents are not required.

2.4 Claim correspondence table

(1) An applicant must submit a claim correspondence table to explain the correspondence of claims determined to be patentable/allowable in the DPMA and all claims in the KIPO.

(2) An applicant must explain how all claims in the KIPO application sufficiently correspond to the patentable/allowable claims in the DPMA application in the table for each KIPO claims based on the criteria in “III.1.3 All claims in the KIPO must sufficiently correspond to one or more of those claims determined to be patentable/allowable in the DPMA” (Also refer to Annex II for the examples of the claim correspondence).

3. Fee for Participation in the PPH

An applicant must pay the fee for preferential examination under the PPH same as other request for preferential examination.

4. Notes on Examination Procedures

The KIPO decides whether the application can undergo preferential examination under the PPH when it receives a request along

with the documents stated above. When the KIPO decides that the request is acceptable, the application is assigned a special status for a preferential examination under the PPH.

The KIPO will not notify the applicant of the acceptance for assigning a special status for preferential examination under the PPH, but instead applicant may recognize it by the reception of an office action resulting from preferential examination.

In those instances where the request does not meet all the requirements set forth above, applicant will be notified and the defects in the request will be identified. Applicant may be given opportunity to perfect the request or may be required to submit a new request. If the PPH request is rejected, the applicant will be notified and the application will await examination in its regular turn.

ANNEX I

Examples of KIPO application eligible for the PPH

1.1.(1) The national application which validly claims priority under the Paris Convention from either a single national DPMA application or multiple national DPMA applications

A Paris Route (Single Priority)

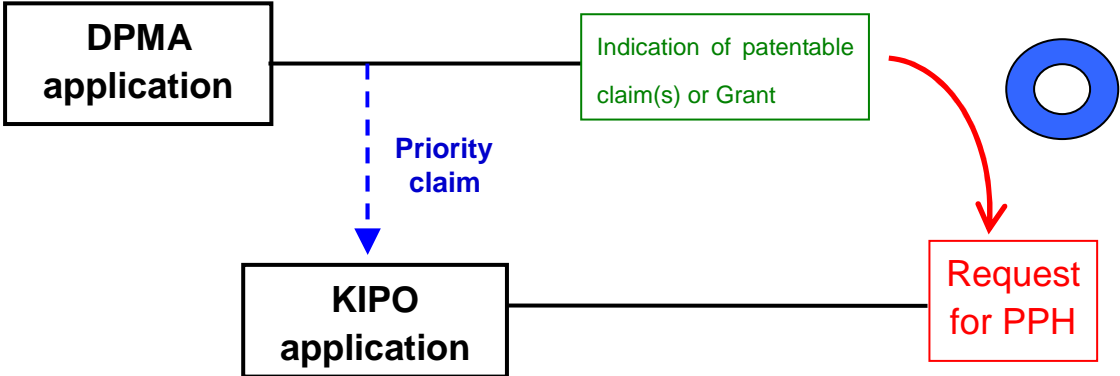

B Paris Route (Multiple Priority)

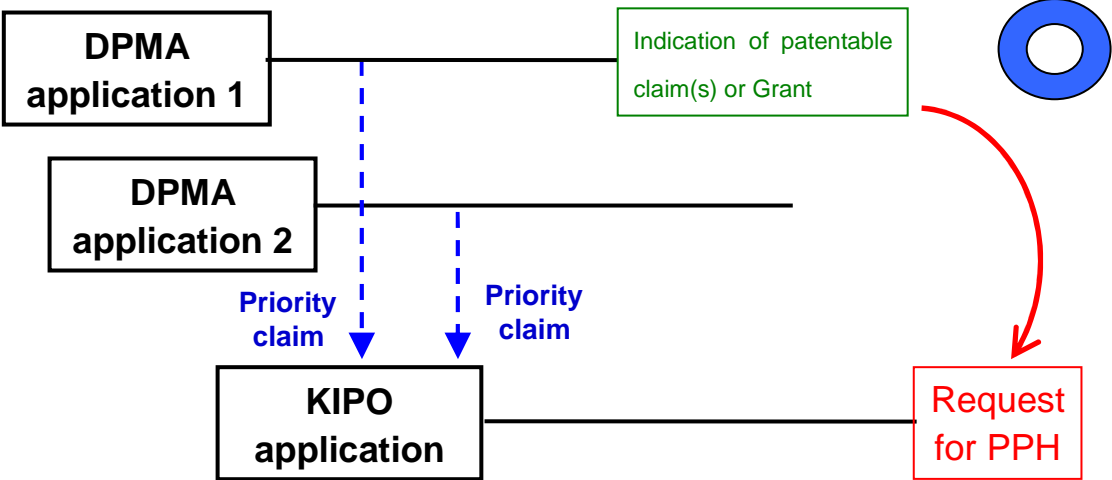

1.1.(1) (continued)

C Paris Route (Domestic Priority)

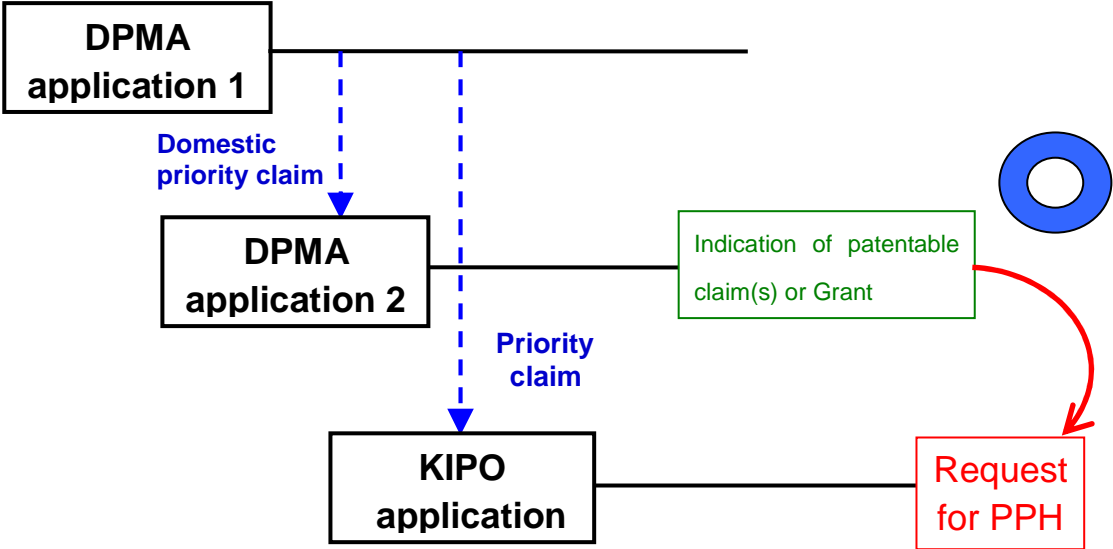

1.1.(2) The PCT national phase application where the PCT international application has validly claimed priority from either a single DPMA national application or multiple national DPMA applications

D PCT Route

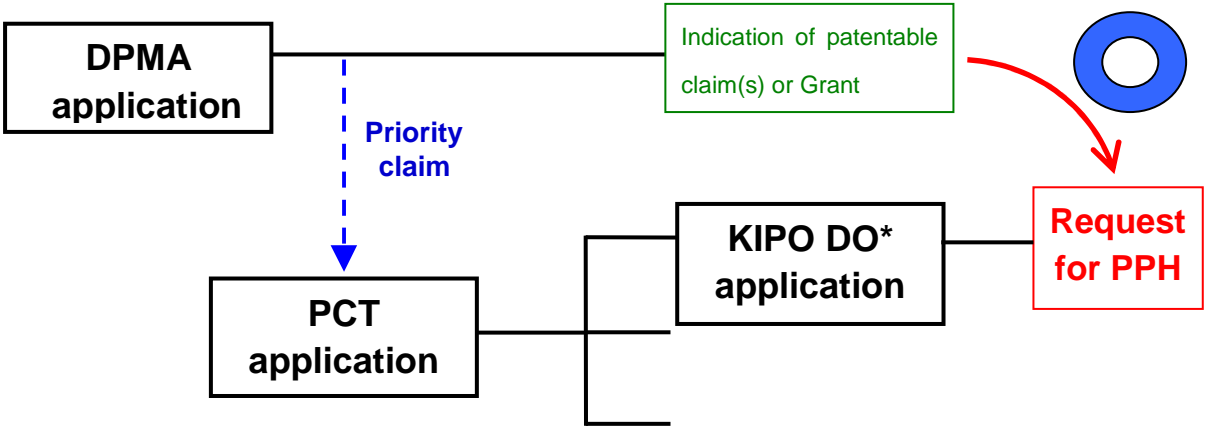

*DO = Designated Office

E PCT Route

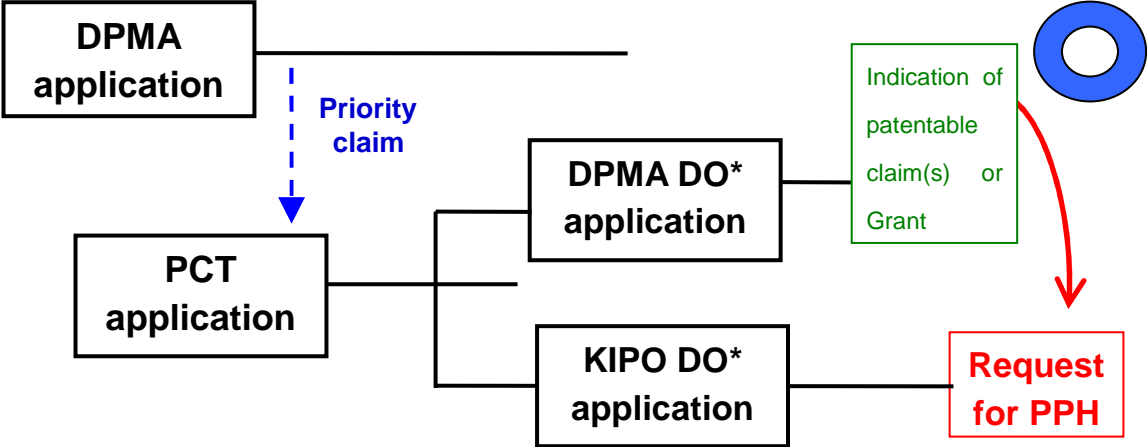

*DO = Designated Office

1.1.(3) The PCT national phase application where the PCT application has no priority claim

F Direct PCT Route

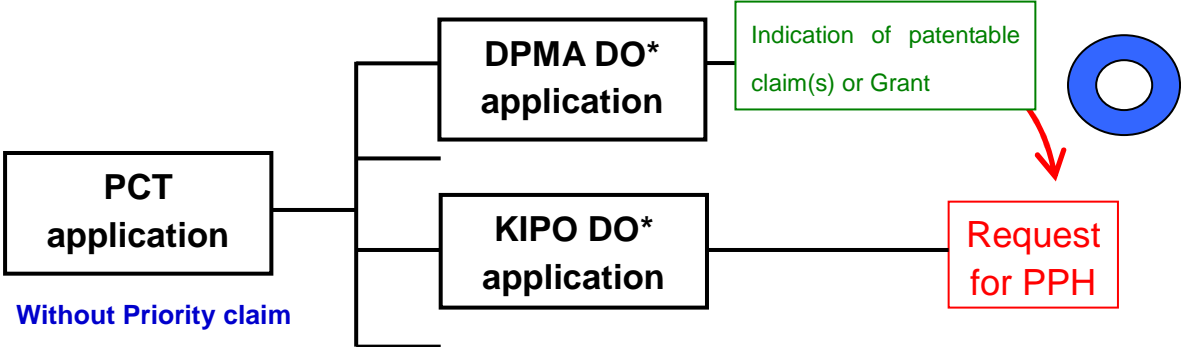

*DO = Designated Office

1.1.(4) The national application that validly claims priority under the Paris Convention from either a single PCT application with no priority claim or multiple PCT applications with no priority claims

G Direct PCT & Paris Route

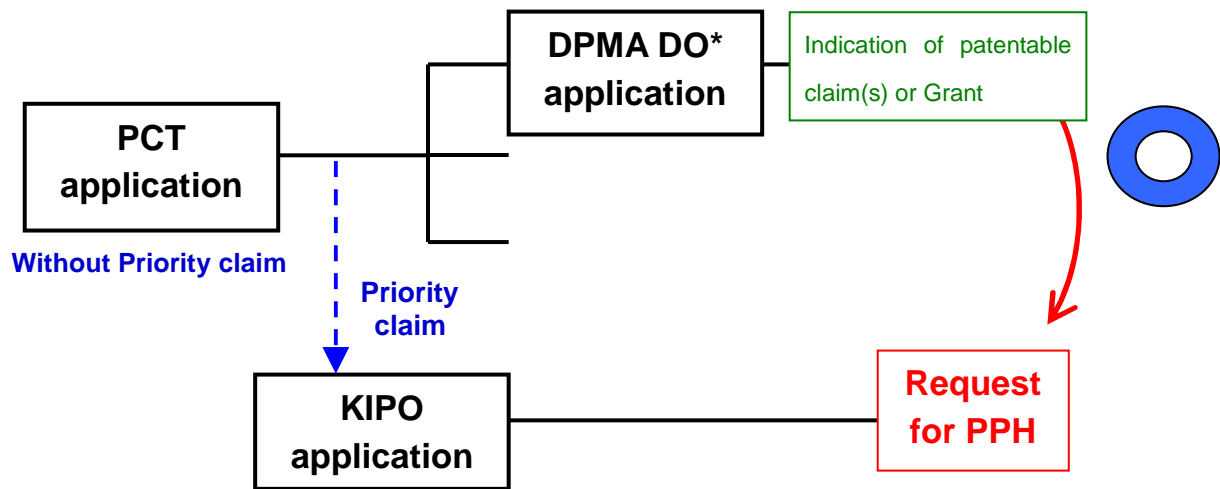

*DO = Designated Office

1.1.(5) The PCT national phase application where the PCT application validly claims priority from a PCT application which has no priority claims

H Direct PCT & PCT Route

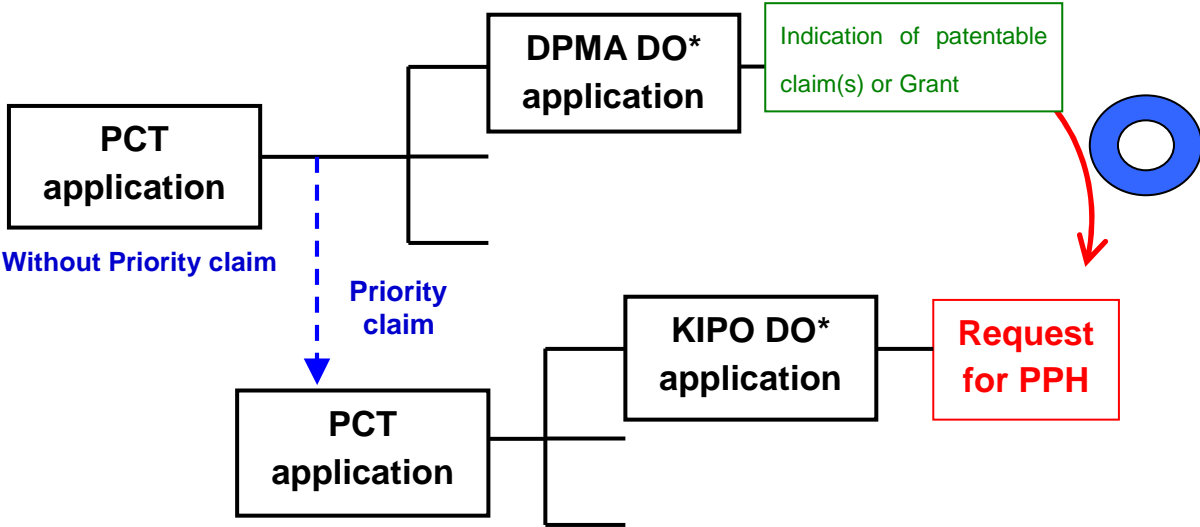

*DO = Designated Office

I Direct PCT & PCT Route

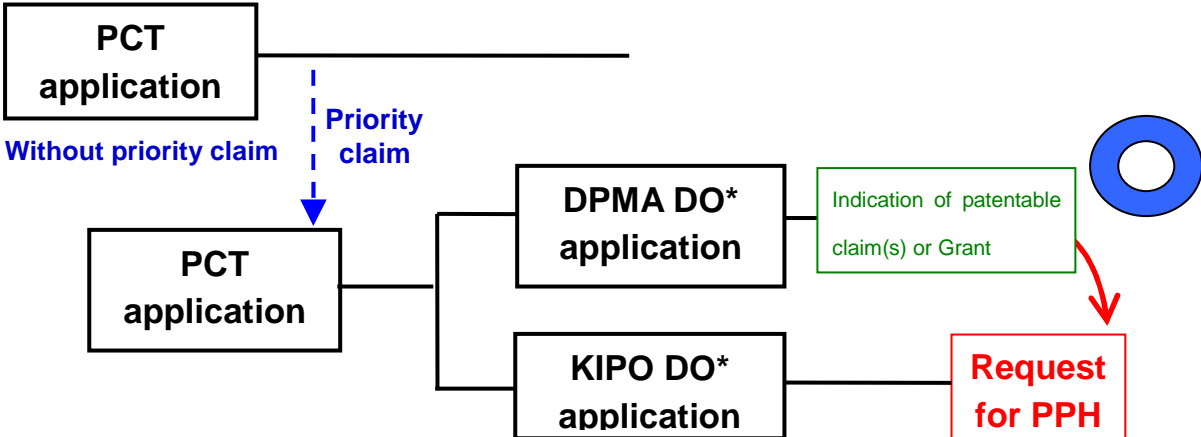

*DO = Designated Office

1.1.(6) The divisional application of an application as referred to in any of (1) to (5)

J Paris (PCT) Route (Divisional Application)

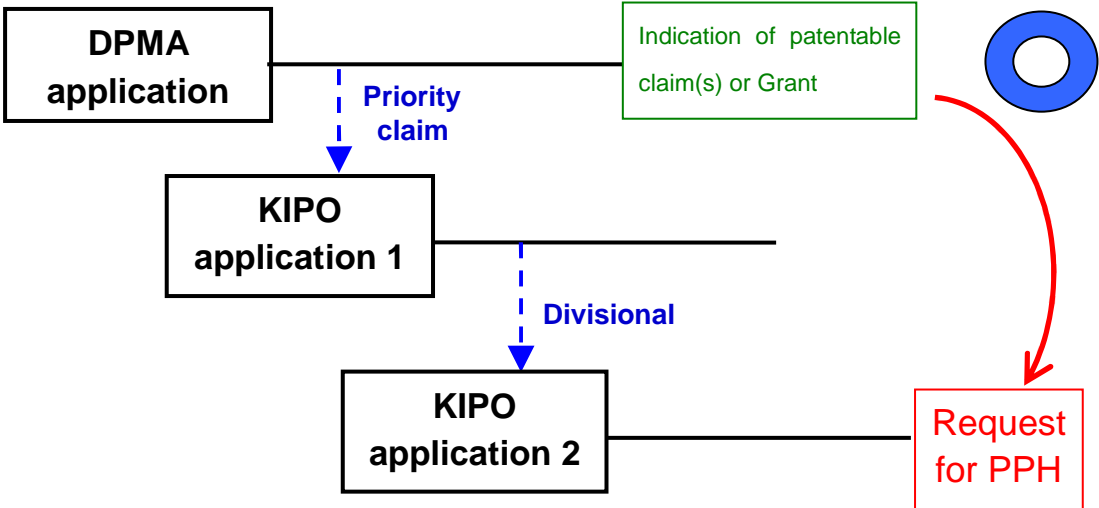

ANNEX II

Examples for the claim correspondence

1. The claims in the following cases (case 1 to case 4) are considered to “sufficiently correspond” to each other.

Case	DPMA claim(s)		KIPO claim(s)		Correspondence
	Claim	Subject matter	Claim	Subject matter	
Case 1	1	A	1	A	The same as DPMA claim 1.
Case 2	1	A	1 2	A A+a	The same as DPMA claim 1. Dependent claim 2 in the KIPO claim is created by adding an element to the DPMA claim.
Case 3	1 2 3	A A+a A+b	1 2 3	A A+b A+a	The same as DPMA claim 1. The same except for claim format. The same except for claim format.
Case 4	1	A	1	A+a	Claim 1 has an additional element ‘a’.

* Where “A” is the subject matter, and “a” and “b” are the additional technical features which are supported in the description

2. The claims in the following cases (case 5 and case 6) are NOT considered to “sufficiently correspond” to each other.

Case	DPMA claim(s)		KIPO claim(s)		Explanation
	Claim	Subject matter	Claim	Subject matter	
Case 5	1	A system	1	A' method	The claimed invention of the KIPO application is a method, whereas the claimed invention of the DPMA application is a system. (The technical features in the DPMA claim are the same as those in the KIPO claim, but categories of both inventions are different)
Case 6	1	A+B	1	A+C	The KIPO claim is different from the DPMA granted claim in a component of the claimed invention. (The KIPO claim is created by altering part of the technical features of the DPMA claim)

ANNEX III

서면

[별지 제 3 호서식]

【서류명】 특허심사하이웨이(PPH)에 의한 우선심사신청설명서

【대상국가】

【본원출원번호】

【대응출원번호】

【본원출원과 대응출원의 관계】

【제출서류】

【특허가능하다고 판단된 특허청구범위】

【서류명 및 제출(발행)일】

【서류제출여부】

(**【제출생략 이유】**)

【번역문제출여부】

(**【제출생략 이유】**)

【심사관련통지서】

【서류명 및 통지일】

【서류제출여부】

(**【제출생략 이유】**)

【번역문제출여부】

(**【제출생략 이유】**)

【심사단계에서 인용된 선행기술문헌】

【명칭】

【제출여부】

(**【제출생략 이유】**)

【청구항간 대응관계설명표】

본원출원의 청구항 번호	대응출원에서 특허가능하다고 판단한 청구항 번호	대응관계 설명

※ 기재요령

1. 【대상국가】란에는 한국 특허청이 특허심사하이웨이를 시행하고 있는 대상국가(일본, 미국, 덴마크, 영국, 캐나다, 러시아, 핀란드, 독일) 중 어느 한 국가의 명칭 기재합니다.
2. 【대응출원번호】란에는 위 대상국가에서 특허가능하다고 판단한 특허청구범위를 포함하고 있는 특허출원의 출원번호 및 출원일을 적습니다.

예) 【대응출원】 JP 평 18-1234 호, 2007. 1. 1.

3. 【본원출원과 대응출원의 관계】란에는 위 대응출원과 본원출원간의 대응 관계를 명확하게 설명합니다. 대응출원에는 조약우선권 주장의 기초가 된 상대국의 특허출원뿐만 아니라 조약우선권 주장의 기초가 된 상대국의 특허출원과 연계되어 있음이 명확한 상대국의 다른 특허출원(예. 분할출원, PCT 국제출원의 조기 국내단계 진입출원)도 포함됩니다.

예) 【본원출원과 대응출원의 관계】 대응출원 JP 18-1234 은 본원출원(분할출원)의 원출원(KR10-2008-12345)이 조약 우선권주장하고 있는 상대국 특허출원 JP 17-5678 의 분할출원으로서 본원출원의 대응(패밀리)특허에 해당합니다.

4. 【특허가능하다고 판단된 특허청구범위】란에는 대상국가에서 특허가능하다고 판단한 특허청구범위가 기재된 서류명 및 제출 여부를 다음과 같이 기재합니다.

가. 【서류명 및 제출(발행)일】란에는 해당 특허청구범위가 기재된 서류의 종류와 제출일, 공보발간된 경우 공보번호와 공개일 등을 함께 기재합니다.

나. 【서류제출여부】란에는 ‘제출’로 기재하고 해당 특허청구범위를 첨부하여 제출합니다. 다만, 심사관이 정보통신망[예. AIPN(일본), public PAIR(미국), PVS online(덴마크) 등]을 통해 해당 특허청구범위를 용이하게 입수할 수 있는 경우에는 제출생략이 가능하므로 【서류제출여부】란에 ‘제출생략’으로 기재하고 【제출생략 이유】란에 생략 가능한 이유를 기재합니다.

다. 해당 특허청구범위가 국어 또는 영어가 아닌 언어로 작성된 경우에는 【번역문제출여부】란을 만들어 ‘제출’로 기재하고 국어 또는 영어로 번역된 번역문을 첨부하여 제출합니다. 다만, 심사관이 정보통신망에서 국어 또는 영어로 된 번역문을 확인할 수 있는 경우에는 제출생략이 가능하므로 【번역문제출여부】란에 ‘제출생략’으로 기재하고 【제출생략 이유】란에 생략 가능한 이유를 기재합니다.

라. 우선심사신청 후 심사관이 해당 특허청구범위를 입수할 수 없거나 국문 또는 영문 번역이 불충분하여 보완지시를 하는 경우에는 해당 서류를 보완하여 제출하여야 합니다.

예 1) 【서류명 및 발행일】 JP2000-123456(2000.01.01)

【서류제출여부】 제출생략

【제출생략 이유】 OOOO 을 통해 심사관이 입수 가능하므로 제출생략

【번역문제출여부】 제출생략

【제출생략 이유】 OOOO 에서 영어 번역문이 제공되므로 제출생략

예 2) 【서류명 및 제출일】 보정서, 2009.06.25 자로 일본특허청에 제출

【서류제출여부】 제출

【번역문제출여부】 제출

5. 【심사관련 통지서】란에는 대응출원에 대한 대상국가의 심사관이 통지한 실제심사 관련 서류명(거절결정서, 등록결정서, 의견제출통지서 등) 및 제출여부를 다음과 같이 기재합니다.

가. 【서류명 및 통지일】란에는 실제심사와 관련하여 통지된 서류의 명칭, 통지일 등을 기재합니다.

나. 【서류제출여부】란에는 ‘제출’로 기재하고 해당 심사관련 통지서를 첨부하여 제출합니다. 다만, 심사관이 정보통신망[예. AIPN(일본), public PAIR(미국), PVS online(덴마크) 등]을 통해 해당 심사관련 통지서를 용이하게 입수할 수 있는 경우에는 제출생략이 가능하므로 【서류제출여부】란에 ‘제출생략’으로 기재하고 【제출생략 이유】란에 생략 가능한 이유를 기재합니다.

다. 해당 통지서가 국어 또는 영어가 아닌 언어로 작성된 경우에는 【번역문제출여부】란을 만들어 ‘제출’로 기재하고 국어 또는 영어로 번역된 번역문을 첨부하여 제출합니다. 다만, 심사관이 정보통신망에서 국어 또는 영어로 된 번역문을 확인할 수 있는 경우에는 제출생략이 가능하므로 【번역문제출여부】란에 ‘제출생략’으로 기재하고 【제출생략 이유】란에 생략 가능한 이유를 기재합니다.

라. 우선심사신청 후 심사관이 해당 통지서를 입수할 수 없거나 국문 또는 영문 번역이 불충분하여 보완지시를 하는 경우에는 해당 서류를 보완하여 제출하여야 합니다.

예 1) 【서류명 및 통지일】 특허사정서, 2008.12.30

【서류제출여부】 제출생략

【제출생략 이유】 정보통신망을 통해 심사관이 입수 가능하므로 제출생략

【번역문제출여부】 제출

6. 【심사단계에서 인용된 선행기술문헌】란에는 심사관련 통지서에서 기재한 선행기술문헌의 명칭 및 제출여부를 다음과 같이 기재합니다.

가. 【명칭】란에는 인용된 선행기술문헌의 종류, 공개일(공보일)을 기재합니다.

나. 【서류제출여부】란에는 ‘제출’로 기재하고 해당 선행기술문헌을 첨부하여 제출합니다. 다만, 심사관이 해당 선행기술문헌을 용이하게 입수할 수 있는 특허문헌(비특허문헌은 제출)은 제출생략이 가능하므로 【제출여부】란에 ‘제출생략’으로 기재하고 【제출생략 이유】란에 생략이유를 기재합니다.

예) 【명칭】 JP2000-123456(2000.01.01), US2004/348454(2004.05.04)

【제출여부】 제출생략

【제출생략 이유】 특허문헌으로 용이하게 입수 가능하므로 제출생략

【명칭】 3GPP TR 29.802 v7.0.0 'Technical Specification Group Core Network and Terminals; (G)MSC-S-(G)MSC-S Nc Interface based on the SIP-I protocol, JUNE 2007(sections 5.7 and 5.8)

【제출여부】 제출

7. 【청구항간 대응관계설명표】란에는 본원출원의 모든 청구항에 대하여 대응되는 “대응출원의 특허가능하다고 판단한 청구항 번호”를 기재하여야 하며, 대응관계 설명 부분에는 양 청구항의 동일 여부 또는 차이점을 구체적으로 기재하여야 합니다.

예)

본원출원의 청구항 번호	대응출원에서 특허가능하다고 판단한 청구항 번호	대응관계 설명
1	1	양 청구항은 동일
2	2	"
3	3	"
4	5	양 청구항은 기재형식의 차이일 뿐 실질적으로 동일
5	6	"
6	4	"
7	1	청구항 7은 대응출원의 청구항 1에 A라는 구성이 부가됨