

## **Procedures to file a request to the JPO for Patent Prosecution Highway Pilot Program between the JPO (Japan Patent Office) and the IMPI (Instituto Mexicano de la Propiedad Industrial)**

Applicants can request accelerated examination by a prescribed procedure including submission of relevant documents on an application which is filed with the JPO and satisfies the following requirements under the JPO-IMPI Patent Prosecution Highway (PPH) pilot program based on the IMPI application.

When filing a request for the PPH pilot program, an applicant must submit a request form “The Explanation of Circumstances Concerning Accelerated Examination” based on the procedure prescribed in “the Guidelines of the Accelerated Examination and Appeal.”<sup>1</sup> Under the PPH pilot program, an applicant is not required to fill in the section “2. the disclosure of prior arts and comparison between the claimed invention and prior art” in “The Explanation of Circumstances Concerning Accelerated Examination”.

The Offices may terminate the PPH pilot program if the volume of participation exceeds manageable level, or for any other reason. Ex Ante notice will be published if the PPH pilot program is terminated.

### **1. Requirements**

**(a) *The JPO application (including PCT national phase application) is***

- (i) *an application which validly claims priority under the Paris Convention to the IMPI application(s) (examples are provided in ANNEX I, figure A, B,E, F and G), or***
- (ii) *a PCT national phase application without priority claim (examples are provided in Annex I, figure H and J), or***
- (iii) *an application which validly claims priority under the Paris Convention to the PCT application(s) without priority claim (examples are provided in ANNEX I, figure I and K).***

The JPO application, which validly claims priority to multiple IMPI or direct PCT applications, or which is the divisional application validly based on the originally filed application that is included in (i) to (iii) above, is also eligible.

**(b) *At least one corresponding application exists in the IMPI and has one or more claims that are determined to be patentable/allowable by the IMPI.***

The corresponding application(s) can be the application which forms the basis of the priority claim, an application which derived from the IMPI application which forms the basis of the priority claim (e.g., a divisional application of the IMPI application), or an IMPI

---

<sup>1</sup> [http://www.jpo.go.jp/torikumi/t\\_torikumi/souki/pdf/v3souki/guideline.pdf](http://www.jpo.go.jp/torikumi/t_torikumi/souki/pdf/v3souki/guideline.pdf)

national phase application of a PCT application (see Figures G, H, I, J and K in Annex I). Claims are “determined to be allowable/patentable” when the JPO examiner clearly identified the claims to be allowable/patentable in the latest office action, even if the application is not granted for patent yet. The office action includes:

- (a) Granted patent
- (b) Decision to Grant a Patent
- (c) Notification of Reasons for Refusal
- (d) Decision of Refusal
- (e) Decision of Legal appeal

**(c) All claims on file, as originally filed or as amended, for examination under the PPH must sufficiently correspond to one or more of those claims indicated as allowable in the IMPI.**

Claims are considered to “sufficiently correspond” where, accounting for differences due to translations and claim format, the claims in the JPO are of the same or similar scope as the claims in the IMPI, or the claims in the JPO are narrower in scope than the claims in the IMPI.

In this regard, a claim that is narrower in scope occurs when an IMPI claim is amended to be further limited by an additional feature that is supported in the specification (description and/or claims).

A claim in the JPO which introduces a new/different category of claims to those claims indicated as allowable in the IMPI is not considered to sufficiently correspond. For example, the IMPI claims only contain claims to a process of manufacturing a product, then the claims in the JPO are not considered to sufficiently correspond if the JPO claims introduce product claims that are dependent on the corresponding process claims.

Any claims amended or added after the grant of the request for participation in the PPH pilot program need not to sufficiently correspond to the claims indicated as patentable/allowable in the IMPI application.

**(d) The JPO has not begun examination of the application at the time of request for the PPH.**

## **2. Documents to be submitted**

Documents (a) to (d) below must be submitted by attaching to “The Explanation of Circumstances Concerning Accelerated Examination”.

Note that even when it is not needed to submit documents below, the name of the documents must be listed in “The Explanation of Circumstances Concerning Accelerated Examination” (Please refer to the Example form for the detail).

- (a) **Copies of all office actions (which are relevant to substantial examination for patentability in the IMPI), which were sent for the corresponding application by the IMPI, and translations of them<sup>2</sup>.**

Either Japanese or English is acceptable as translation language.

- (b) **Copies of all claims determined to be patentable/allowable by the IMPI, and translations of them<sup>2</sup>.**

Either Japanese or English is acceptable as translation language.

- (c) **Copies of references cited by the IMPI examiner**

If the references are patent documents, the applicant doesn't have to submit them because the JPO usually possesses them. When the JPO does not possess the patent document, the applicant has to submit the patent document at the examiner's request. Non-patent literature must always be submitted.

The translations of the references are unnecessary.

- (d) **Claim correspondence table**

The applicant requesting PPH must submit a claim correspondence table, which indicates how all claims in the JPO application sufficiently correspond to the patentable/allowable claims in the IMPI application.

When claims are just literal translation, the applicant can just write down that "they are the same" in the table. When claims are not just literal translation, it is necessary to explain the sufficient correspondence of each claim based on the criteria (1) (c) (Please refer to the Example form).

When the applicant has already submitted above documents (a) to (d) to the JPO through simultaneous or past procedures, the applicant may incorporate the documents by reference and does not have to attach them.

### **3. Example of "The Explanation of Circumstances Concerning Accelerated Examination" for filing request an accelerated examination under the PPH pilot program**

---

<sup>2</sup> Machine translations will be admissible, but if it is impossible for the examiner to understand the outline of the translated office action or claims due to insufficient translation, the examiner can request the applicant to resubmit translations.

### **(1) Circumstances**

When an applicant files a request for an accelerated examination under the PPH pilot program to the JPO, an applicant must submit a request form “The Explanation of Circumstances Concerning Accelerated Examination” based on the procedure prescribed in “the Guidelines of the Accelerated Examination and Appeal”<sup>3</sup>.

The applicant must indicate that the application is included in (i) to (iii) of 1. (a), and that the accelerated examination is requested under the PPH pilot program. The application number, publication number, or a patent number of the corresponding IMPI application(s) also must be written.

\*In the case that the application which has one or more claims that are determined to be patentable/allowable is different from the IMPI application(s) included in (i) to (iii) of 1. (a) (for example, the divisional application of the basic application), the application number, publication number, or a patent number of the application(s) which has claims determined to be patentable/allowable and the relationship between those applications also must be written.

### **(2) Documents to be submitted**

The applicant must list all required documents mentioned above 2. in an identifiable way, even when applicant omits to submit certain documents.

### **(3) Notice**

Forms of “The Explanation of Circumstances Concerning Accelerated Examination” are different between on-line procedure and paper procedure. Please refer to the examples of forms when filling in (“Form 1 for Accelerated Examination” for on-line procedures, and “Form 2 for Accelerated Examination” for paper procedures.).

---

<sup>3</sup> [http://www.jpo.go.jp/torikumi/t\\_torikumi/souki/pdf/v3souki/guideline.pdf](http://www.jpo.go.jp/torikumi/t_torikumi/souki/pdf/v3souki/guideline.pdf)

**Example form of on-line procedures**

(Example of the request based on the claims indicated patentable/allowable in the written opinion of the report on the state of the art)

<p><b>【書類名】</b> 早期審査に関する事情説明書                  -----                  The name of this paper</p> <p><b>【提出日】</b> 平成00年00月00日                  -----                  Date of filing</p> <p><b>【あて先】</b> 特許庁長官殿                  -----                  Destination</p> <p><b>【事件の表示】</b>  <b>【出願番号】</b> 特願 0000-000000                  -----                  Application number</p> <p><b>【提出者】</b>  <b>【識別番号】</b> 000000000  <b>【住所又は居所】</b> 〇〇県〇〇市〇丁目  <b>【氏名又は名称】</b> 〇〇〇〇〇                  -----                  The name and address of who submit this</p> <p><b>【代理人】</b>  <b>【識別番号】</b> 000000000  <b>【住所又は居所】</b> 〇〇県〇〇市〇丁目  <b>【氏名又は名称】</b> 〇〇 〇〇                  -----                  The name and address of the attorney</p>	<p style="border: 1px solid orange; padding: 5px; display: inline-block;">Bibliographical items</p>
<p><b>【早期審査に関する事情説明】</b>                  -----                  The explanation of circumstances concerning accelerated examination</p> <p>1. 事情                  本出願はメキシコ産業財産庁への出願(特許出願番号 P0000-00000)をパリ条約に基づく優先権の基礎出願とする出願であり、特許審査ハイウェイ試行プログラムに基づく早期審査の申請を行うものである。</p> <p style="border: 1px dashed black; padding: 5px;">1. Circumstances                  This application is an application validly claiming the priority under the Paris Convention to the corresponding IMPI application (the application number is 000000000), and the accelerated examination is requested under the PPH pilot program.</p> <p>以下において、「引用非特許文献1」とは、「村岡洋一著、「コンピュータサイエンス大学講座(第 11 巻) コンピュータ・アーキテクチャ」、第 2 版、株式会社近代科学者、1985 年 11 月、p. 123 - 127」である。</p> <p style="border: 1px dashed black; padding: 5px;">In what follows, “non-patent literature1” is “Yoichi Muraoka, Lecture of Computer Science (vol.11) computer architecture, 2<sup>nd</sup> edition, Scientist com, Nov. 1985, p.123-127.”</p>	

If the name of the document is long (over than 50 letters), it is impossible to write it down directly to the column “【物件名】.” Please write down the full name of the document in the column “【早期審査に関する事情説明】” and name it properly. Then write the name in the column “【物件名】.”

(提出を省略する物件)

(物件名) 対応メキシコ出願に対して引用されたメキシコ出願公開00000号公報

(物件名) 対応メキシコ出願に対して引用された日本国特許第00000号公報

List up the documents which can be omitted to submit

(Documents to be omitted to submit)

(The name of the document) Cited reference of the corresponding IMPI application: Mexican Publication of application 0000000

(The name of the document) Cited reference of the corresponding IMPI application: Japan Patent publication of application 0000000

【提出物件の目録】

List up the documents to be submitted

The list of submitted documents

【物件名】 IMPI 出願と本出願の請求項の対応関係を示す書面 1

【物件名】 対応 IMPI 出願に対する\*\*年\*\*月\*\*日付の拒絶理由通知書及びその翻訳文 1

【物件名】 対応 IMPI 出願に対する\*\*年\*\*月\*\*日付の特許査定およびその翻訳文 1

【物件名】 対応 IMPI 出願で特許可能と判断された請求項の写し及びその翻訳文 1

【物件名】 引用非特許文献 1

(The name of the document) The table to explain how the claims indicated as allowable in the IMPI sufficiently correspond to the claims in the JPO application 1

(The name of the document) Copy and translation of Notification of Reasons for Refusal in the IMPI on (date) 1

(The name of the document) Copy and translation of grant in the IMPI on (date) 1

(The name of the document) Copy and translation of the claims indicated patentable in the report on the state of the art and written opinion in the IMPI on (date) 1

(The name of the document) Cited non patent literature 1

Use the same name as “【物件名】” under “【提出物件の目録】.”

Attach the document here as image file or text.

【添付物件】

The list of attached documents

【物件名】 IMPI 出願と本出願の請求項の対応関係を示す書面

The table to explain how the claims indicated as allowable in the IMPI sufficiently correspond to the claims in the JPO application

【内容】

本出願の請求項	メキシコで特許可能とされた請求項	対応関係に関するコメント
The claim in the JPO	The patentable claim in the IMPI	Comments about the correspondence
1	1	両クレームは同一である。 Both claims are the same.
2	2	”
3	1	両クレームは、記載形式を除き同一である。 Both claims are the same except the claim format.
4	2	”
5	1	請求項5は、対応する IMPI 出願の請求項1にAという技術的特徴を付加したものである。 Claim 5 in the JPO adds feature A to Claim 1 in the IMPI

【物件名】 対応 IMPI 出願に対する\*\*年\*\*月\*\*日付の拒絶理由通知書及びその翻訳文 1

Copy and translation of Notification of Reasons for Refusal in the IMPI on

【内容】 Attach the copy of the document.

Use the same name as “【物件名】” under “【提出物件の目録】.”

【物件名】 対応 IMPI 出願に対する\*\*年\*\*月\*\*日付の特許査定およびその翻訳文 1

Copy and translation of grant in the IMPI on (date) 1

【内容】 Attach the copy of the document.

【物件名】 対応メキシコ出願で特許可能と判断された請求項の写し及びその翻訳文 1

Copy and translation of the claims indicated patentable in the report on the state of the art and written opinion in the IMPI on (date) 1

【内容】

Attach the copy of the document.

【物件名】 引用非特許文献1

Cited non-patent literature1

【内容】

Attach the copy of the document.

Note that in the case of paper procedure, the pendency period (the period between the request for PPH and the first office action) tends to be longer than on-line procedure.

**A** A case meeting requirement (a) (i)  
- Paris route -

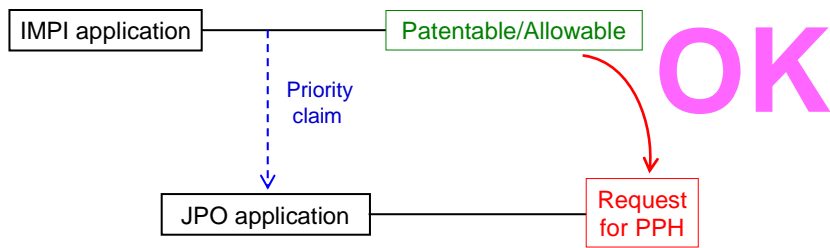

**B** A case meeting requirement (a) (i)  
- PCT route -

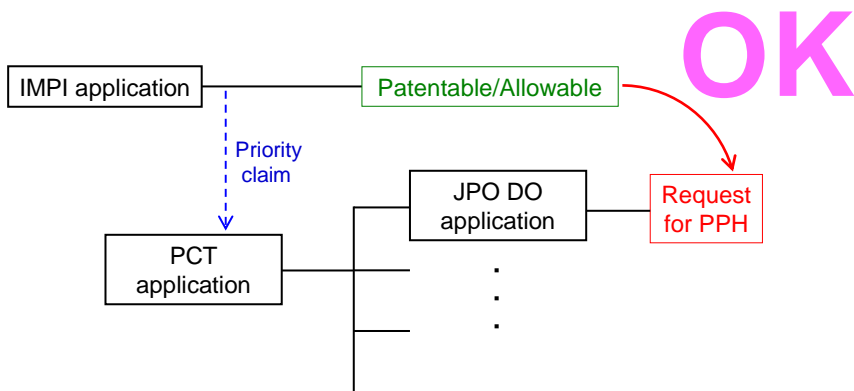

**C** A case not meeting requirement (a)  
- Paris route, but the first application is from the third country -

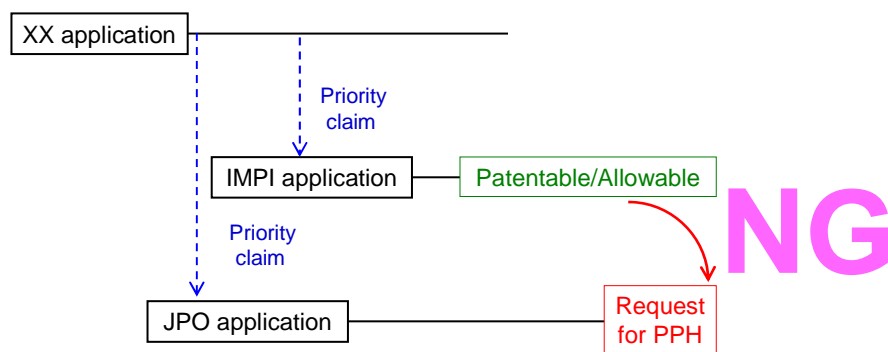

XX : the office other than the IMPI

**D** A case not meeting requirement (a)  
- PCT route, but the first application is from the third country -

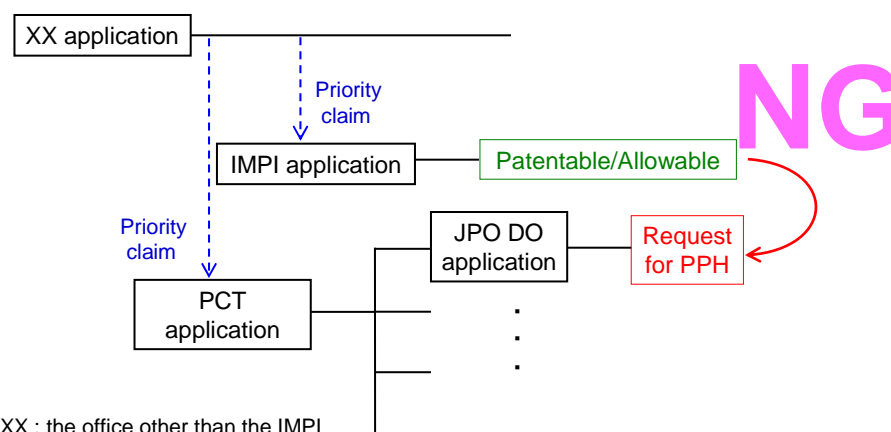

XX : the office other than the IMPI

**E** A case meeting requirement (a) (i)  
- Paris route & Complex priority -

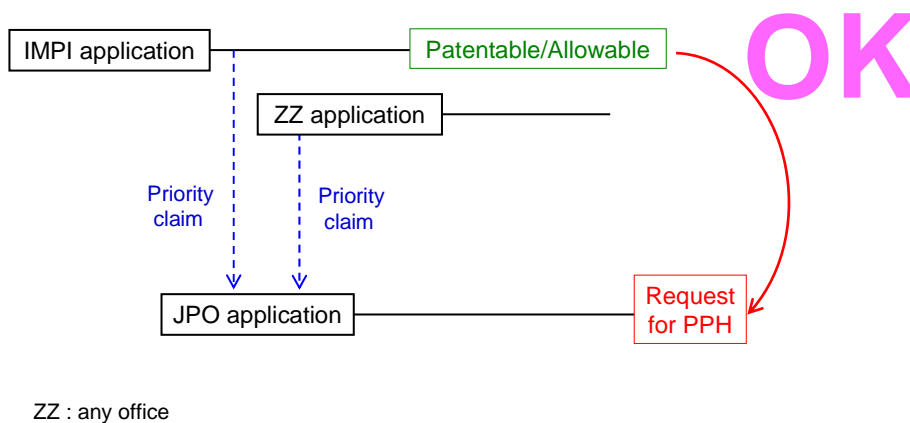

**F** A case meeting requirement (a) (i)  
- Paris route & divisional application -

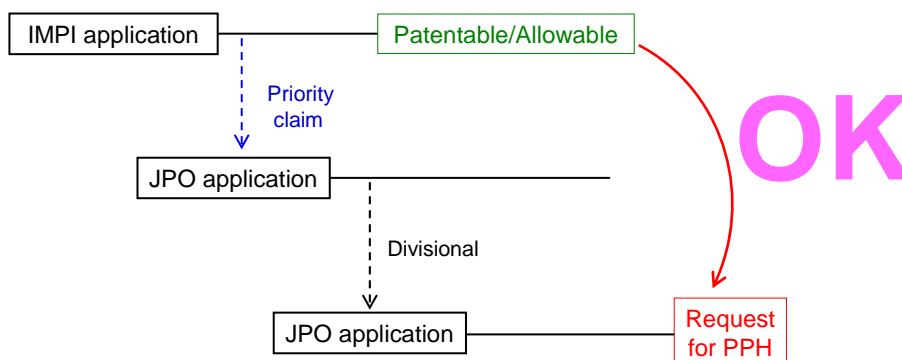

**G** A case meeting requirement (a) (i)  
- PCT route -

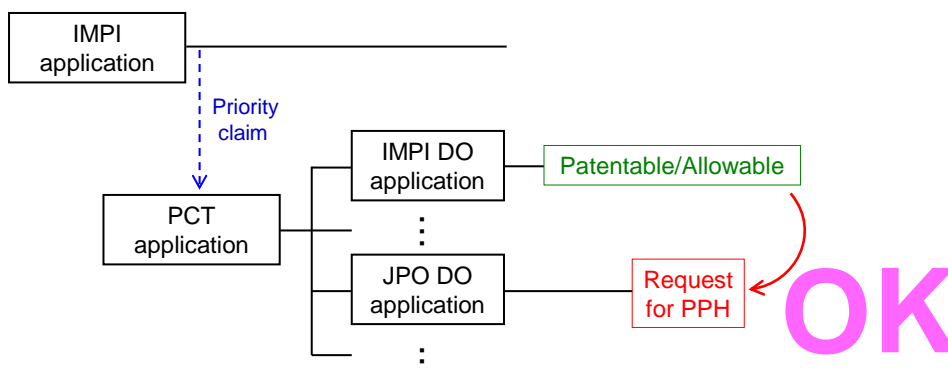

**H** A case meeting requirement (a) (ii)  
- Direct PCT route -

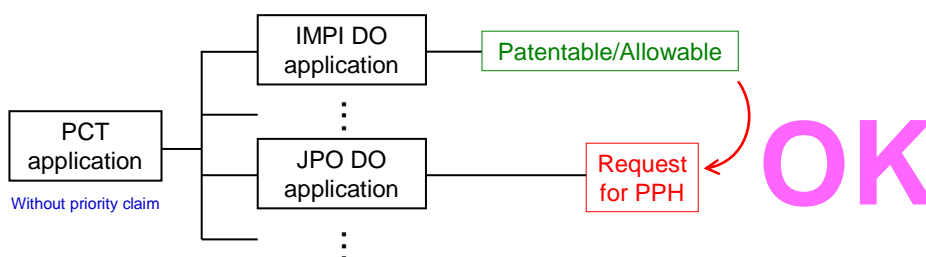

**I** A case meeting requirement (a) (iii)  
- Direct PCT & Paris route -

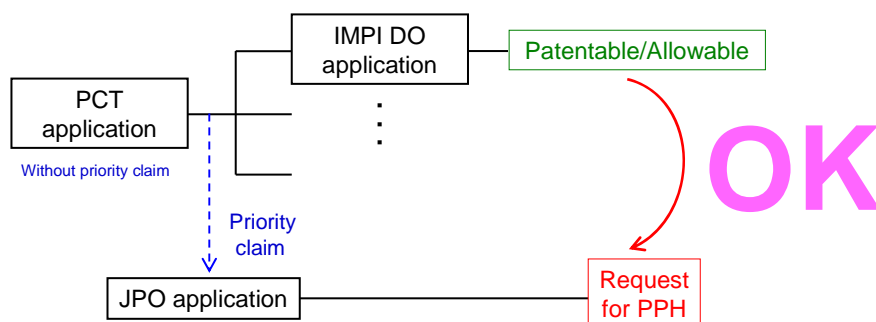

**J** A case meeting requirement (a) (iii)  
- Direct PCT & PCT route -

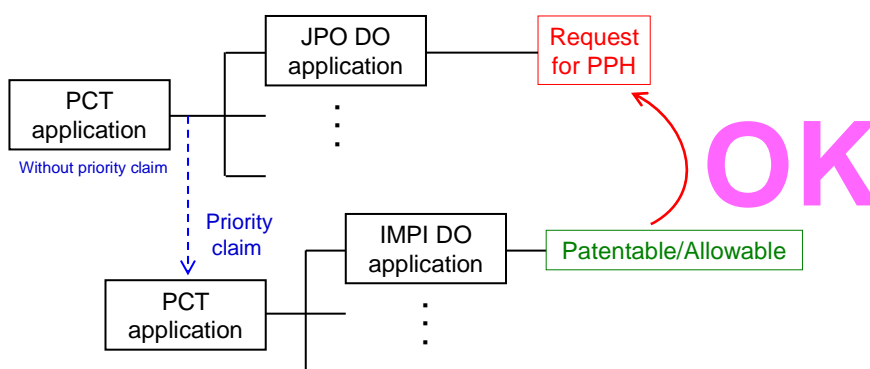

**K** A case meeting requirement (a) (iii)  
- Direct PCT & PCT route -

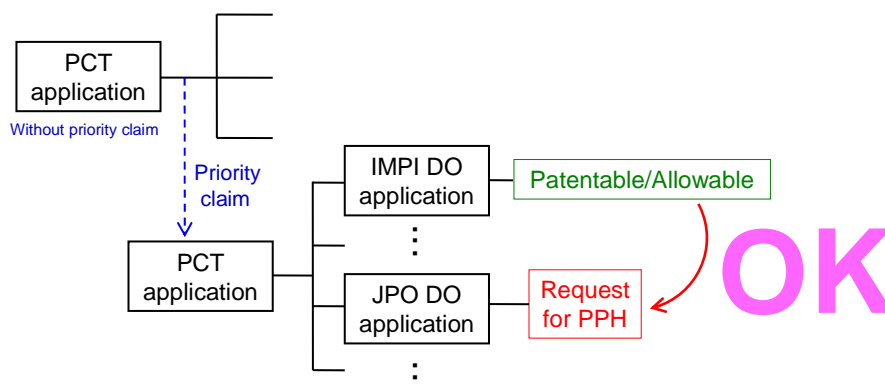

**L** A case not meeting requirement (d)  
- Examination has begun before a request for PPH -

