

Procedures to file a request to the NBPR (National Board of Patent and Registration of Finland) for Patent Prosecution Highway Pilot Program between the KIPO (Korean Intellectual Property Office) and the NBPR

I. Request to the NBPR

[0001] An applicant should file a request for accelerated examination under the Patent Prosecution Highway (PPH) to the NBPR by submitting a letter requesting accelerated examination under the PPH accompanied by the relevant supporting documents. The requirements for an application to the NBPR for accelerated examination under the PPH are given in the following section. Relevant supporting documentation is discussed in a later section 2 (paragraphs [0003]-[0005]) as is the general NBPR application procedure envisaged at this time (paragraph [0006]) section 3.

II. Trial Period for the PPH Pilot Program

The PPH pilot program will commence on January 4, 2010, for a period of one year ending on January 3, 2011. The offices will evaluate the results of the pilot program to determine whether and how the program should be fully implemented after the trial period.

III. Requirements for requesting an accelerated examination under the PPH pilot program at the NBPR

[0002] There are four requirements for requesting accelerated examination under the PPH pilot program at the NBPR. These are:

1.1 The NBPR application (including a PCT national applications) is either:

- (1) a national application which validly claims priority under the Paris Convention from either a single national KIPO application or multiple national KIPO applications (examples are provided in Annex III, Figure A, B, C), or

- (2) a PCT national phase application where the PCT international application has validly claimed priority from either a single KIPO national application or multiple national KIPO applications (examples are provided in Annex III, Figure D, E), or
- (3) a PCT national phase application where the PCT application has no priority claim (example is provided in Annex III, Figure F), or
- (4) a national application that validly claims priority under the Paris Convention from either a single PCT international application with no priority claim or multiple PCT international applications with no priority claims (example is provided in Annex III, Figure G), or
- (5) a PCT national phase application where the PCT application validly claims priority from a PCT international application which has no priority claims (examples are provided in Annex III, Figure H, I), or
- (6) a divisional application of an application as referred to in any of (1) to (5) (examples are provided in Annex III, Figure J).

The NBPR application which validly claims priority from a Korean utility model application which is conducted substantive examination under the New ACT after October 1, 2006 is also eligible.

Refer to Annex III for illustrated examples of the above applications.

The NBPR application, which validly claims priority to multiple KIPO or PCT applications, or which is the divisional application validly based on the originally filed application that is included in 1 to 6 above, is also eligible.

It is noted that the application is NOT eligible for the PPH pilot program in case where the examination was conducted in the EPO (not in KIPO) and the patent right was validated in NBPR as a designated state.

1.2 The corresponding application(s) in the KIPO has one or more claim(s) determined to be patentable/allowable by the KIPO

The patentable/allowable claims of the KIPO are the claims which are explicitly identified as patentable/allowable in the granted patent publication or in the office action by the KIPO. Claims clearly identified to be patentable/allowable by the KIPO in the latest office action at examination stage can form the basis of a request for an accelerated examination under the PPH, even if the application which includes those claims is not granted for patent yet.

The following cases will fall within this interpretation:

- A KIPO examiner clearly identifies those claims to be patentable/allowable in either "Notice of Submission of Opinion" or "Notice of Final Rejection" by adding the following expression of "PATENTABLE(REGISTRABLE) CLAIM(S):

Corresponding application in the KIPO whose claims are determined to be patentable/allowable does not have to be the application for which priority is claimed in the NBPR application (the basic application). The KIPO application can be an application explicitly derived from the basic application, e.g., a divisional application of the basic application, a converted application of the basic application or an application which claims domestic priority to the basic application (Refer to Example C and J in Annex III).

[Note]

Where the KIPO application that contains the patentable/allowable claims is not the same application for which priority is claimed in the NBPR application, applicant must identify the relationship between the KIPO application that contains the patentable/allowable claims and the KIPO priority application claimed in the NBPR application.

1.3 All claims in the NBPR application must sufficiently correspond to one or more of those claims determined to be patentable/allowable in the KIPO.

All the claims in the NBPR application for which a request in the PPH program is made must sufficiently correspond or be amended to sufficiently correspond to one or more

of patentable/allowable claims in the KIPO application(s).

Claims are considered to "sufficiently correspond" where the claims in the NBPR are the same or substantially same as the claims in the KIPO, or have additions or further limitations of specific features resulting that the claims in the NBPR fall within the scope of the claims in the KIPO.

A claim in the NBPR which introduces a new/different category of claims to those claims indicated as allowable in the KIPO is NOT considered to sufficiently correspond. For example, the KIPO claims only contain claims to a process of manufacturing a product, then the claims in the NBPR are not considered to sufficiently correspond if the NBPR claims introduce product claims that are dependent on the corresponding process claims.

It is not necessary to include "all" claims determined to be patentable/allowable in the KIPO in an application in the NBPR (the deletion of claims is allowable). For example, in the case where an application in the KIPO contains 5 claims determined to be patentable/allowable, the corresponding application in the NBPR may contain only 3 of these 5 claims.

Refer to Annex I for the cases which are considered to "sufficiently correspond" and the cases which are not considered to "sufficiently correspond".

When claims become determined to be patentable/allowable in the KIPO by making amendment to claims in the KIPO application, the claims in the NBPR application should be amended in a similar way to sufficiently correspond to the patentable/allowable claims in the KIPO application.

1.4 The NBPR has not yet issued a communication "Communication of Approval" (The heading of the communication is "Hyväksyvä välipäätös").

The heading for such a communication will be "Hyväksyvä välipäätös".

2. Required documents for accelerated examination under the PPH pilot program at the NBPR

[0003] The following documentation will be needed to support a request for accelerated examination under the PPH pilot program at the NBPR:

2.1 Copies of all office actions in the KIPO, which were sent for the corresponding application by the KIPO, and translations of them.

The term "office actions" is here used about the correspondence sent to the applicant or the applicant's representative from the KIPO examiner.

The office actions are limited to "Notice of Submission of Opinion" and "Notice of Final Rejection" (Decision of granting a patent is excluded)

No paper copy and translation of the office actions need be supplied if the office actions are available via K-PION (<http://www.k-pion.net>), as machine translation into English is available to the NBPR examiner via K-PION.

If the office actions or the translations are not available via K-PION, the applicant must supply copies of the office actions and the translations hereof into either English or Finnish to the NBPR. Machine translation is admissible.

It is noted that applicants must also submit copies of any office actions (which are relevant to patentability) arising from the KIPO application(s) and issued after the grant of the request for participation in the PPH pilot program in the NBPR (especially where KIPO might have reversed a prior holding of patentability).

However, it is noted that the machine translation should be basically limited to officially recognized machine translation by KIPO. If it is impossible for the examiner to understand the translated claims due to insufficient translation, the examiner may request the applicant to submit (or resubmit) translations. It is noted that the request for PPH should not be rejected because the machine translation is not enough to understand the translation.

2.2 Copies of all claims determined to be patentable by the KIPO, and translations of them.

The applicant can either provide the claims together with the request for acceleration under the PPH or request that the NBPR obtains the claims from KIPO's database K-PION.

Both Finnish and English are acceptable as translation language. The descriptions above in requirement (2.1) - regarding the occasions where the applicant is not required to submit copies and translations and regarding machine translations - also applies to this requirement (2.2).

2.3 Copies of references cited by KIPO examiner

If the references are patent documents, it will not be necessary to submit these documents, as they will usually be available to the NBPR. If the NBPR does not have access to the relevant patent documents, the applicant must submit these documents at the request of the NBPR. Non-patent literature must always be submitted.

Submission of translation of the references is not required. However, applicants will be free to file translations as part of the supporting documentation when initially requesting accelerated examination under the PPH to allow prompt consideration of the citations if they so desire.

2.4 Claim correspondence table

Sufficient correspondence of claims occurs where the claims are of the same or similar scope as defined above in section [0002]. The claim correspondence table must indicate how all the claims in the NBPR application correspond to the patentable claims in the KIPO application as shown in Annex II. The claim correspondence table must be written in either English or Finnish.

Where the claims applied for at the NBPR are literal translations of the claims which the KIPO has determined to be patentable, it will be sufficient to write "they are the same" in the table of correspondence. When the claims applied for at the NBPR are not literal translations, it will be necessary to explain why there is a sufficient correspondence of each claim based on the criteria set out in section [0002] above.

Any claims amended or added after the grant of the request for participation in the PPH pilot program must sufficiently correspond to one or more allowable/patentable claims in the KIPO application(s). Applicant is required to submit a new claims

correspondence table along with the amendments. If the amended or newly added claims do not sufficiently correspond to the allowable/patentable claims in the NBPR application(s), the applicant will be notified that the application will await examination in its regular turn.

[0004] The applicant is required to complete a form for requesting accelerated examination under the PPH pilot program (as given in Annex II) which will be available for download from the NBPR website (<http://www.prh.fi/en/patentit/pph.html>). The form must be sent to the NBPR along with a letter requesting acceleration under the PPH and the relevant supporting documentation.

[0005] The applicant need not provide further copies of documentation if they have already submitted the documents noted above to the NBPR through simultaneous or past procedures.

In those rare situations where the KIPO application has not been published, and therefore the KIPO dossier is not available via KIPO's database K-PION, applicant will be responsible for providing the necessary documents to the NBPR.

3. Procedure for accelerated examination under the PPH pilot program at the NBPR

[0006] The applicant files a letter requesting accelerated examination under the PPH pilot program to the NBPR, including the relevant supporting documents and a completed request form. The PPH administrator will consider the request and if all requirements are met the PPH administrator will send an appropriate message to the relevant examining group. The NBPR's patent examiners will conduct the accelerated examinations.

In those instances where the request does not meet all the requirements set forth above, applicant will be notified and the defects in the request will be identified. Applicant may be given opportunity to perfect the request or may be required to submit a new request. If the PPH request is rejected, the applicant will be notified and the application will await examination in its regular turn.

ANNEX I

Examples for the claim correspondence

1. The claims in the following cases (case 1 to case 4) are considered to “sufficiently correspond” to each other.

Case	KIPO claim(s)		NBPR claim(s)		Correspondence
	Claim	Subject matter	Claim	Subject matter	
Case 1	1	A	1	A	The same as KIPO claim 1.
Case 2	1	A	1 2	A A+a	The same as KIPO claim 1. Dependent claim 2 in the NBPR claim is created by adding an element to the OFF claim.
Case 3	1 2 3	A A+a A+b	1 2 3	A A+b A+a	The same as KIPO claim 1. The same except for claim format. The same except for claim format.
Case 4	1	A	1	A+a	Claim 1 has an additional element 'a'.

** Where "A" is the subject matter, and "a" and "b" are the additional technical features which are supported in the description*

2. The claims in the following cases (case 5 and case 6) are NOT considered to “sufficiently correspond” to each other.

Case	KIPO claim(s)		NBPR claim(s)		Explanation
	Claim	Subject matter	Claim	Subject matter	
Case 5	1	A system	1	A' method	The claimed invention of the NBPR application is a method, whereas the claimed invention of the KIPO application is a system. (The technical features in the KIPO claim are the same as those in the NBPR claim, but categories of both inventions are different)
Case 6	1	A+B	1	A+C	The NBPR claim is different from the KIPO granted claim in a component of the claimed invention. (The NBPR claim is created by altering part of the technical features of the KIPO claim)

ANNEX II

PPH REQUEST

Request for Accelerated Examination at the NBPR under the Patent Prosecution Highway Pilot Program between the NBPR and the KIPO

1. FI application number:

Corresponding KR application number(s):

2. **Either:**

a) Copy of KIPO office action(s) attached:

and

Copy of translated KIPO office action(s) attached

or

b) KIPO office action(s) available on K-PION:

or

c) KIPO office action(s) on file from previous PPH application:
FI application number:

3. **Either:**

a) Copy of claims of corresponding KR application attached:

and

Copy of translated claims of corresponding KR application attached:

or

b) Claims of corresponding KR application available on K-PION:

or

c) KR application claims on file from previous PPH application:
FI application number:

4. Translation version of foreign language citation attached

(Please note that it is not necessary to provide translation of documents.

However, applicant will be free to file translations to allow prompt consideration of the citations if they so desire.)

5. Claim correspondence table completed:

ANNEX III

A Paris Route (Single Priority)

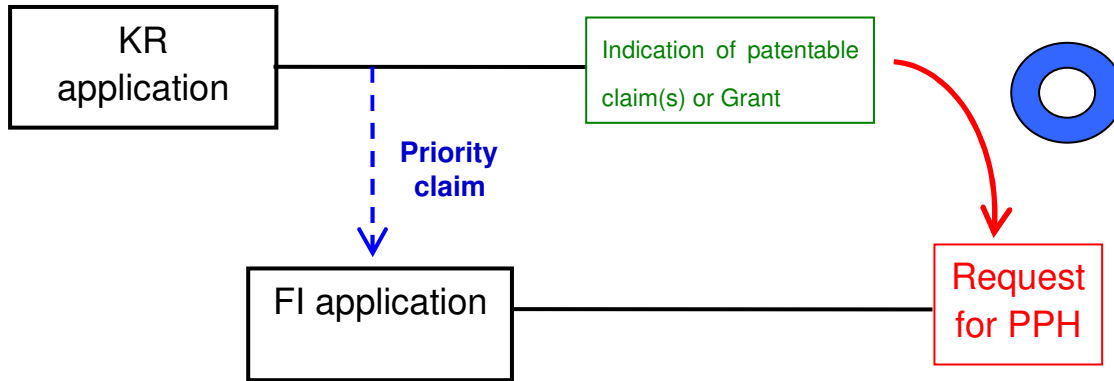

B Paris Route (Multiple Priority)

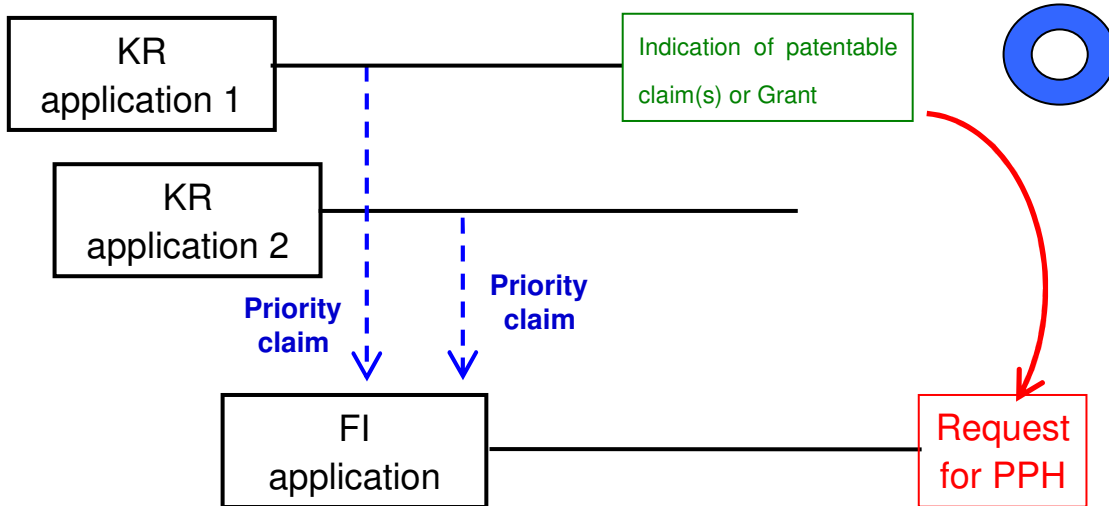

1.1.(1) (continued)

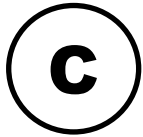

Paris Route (Domestic Priority)

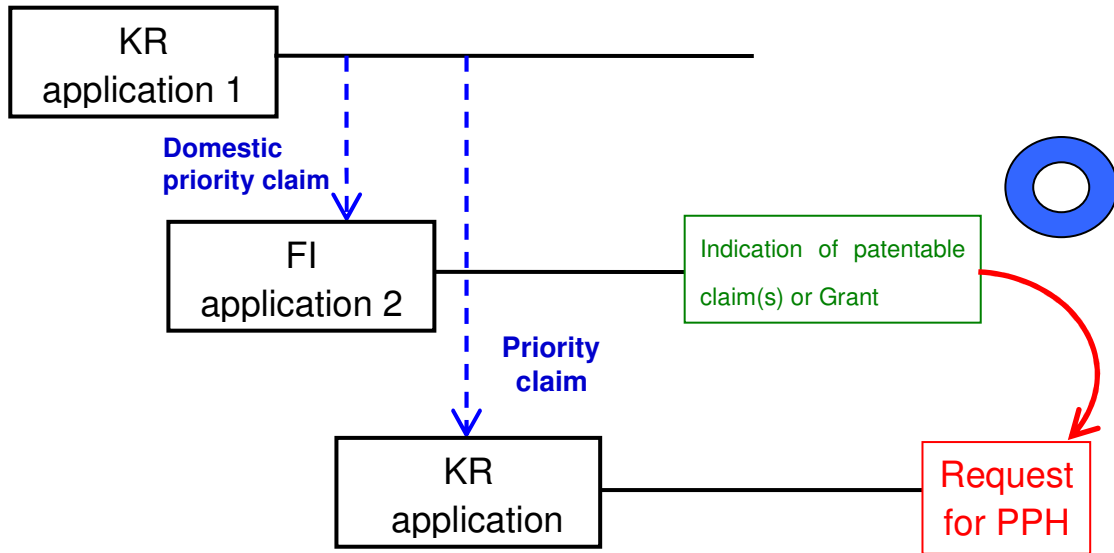

**1.1.(2) The PCT national phase application where the PCT international application has validly claimed priority from either a single KIPO national application or multiple national KIPO applications
(A Korean Utility Model is also included in the KIPO application.)**

D PCT Route

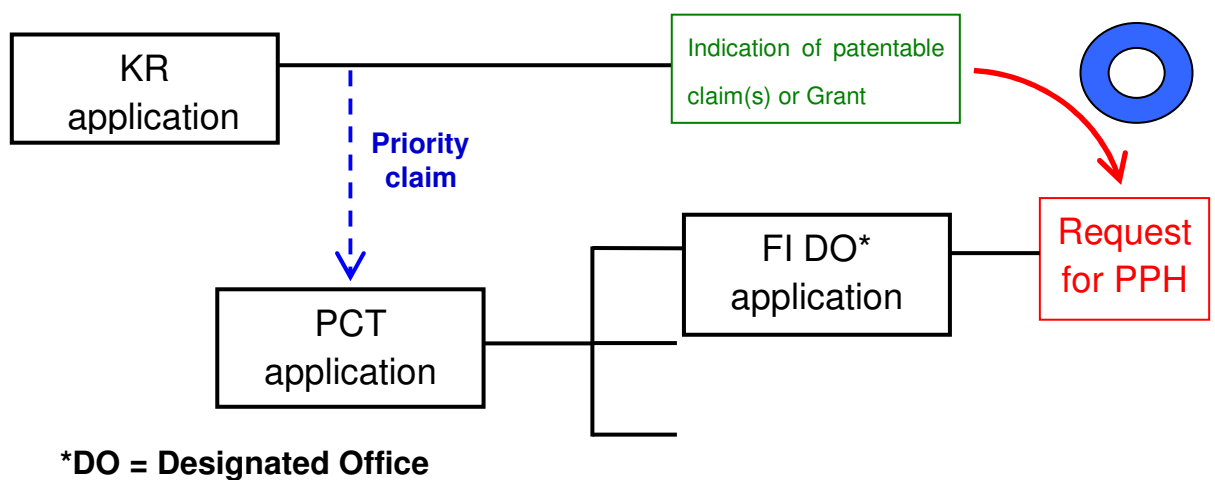

E PCT Route

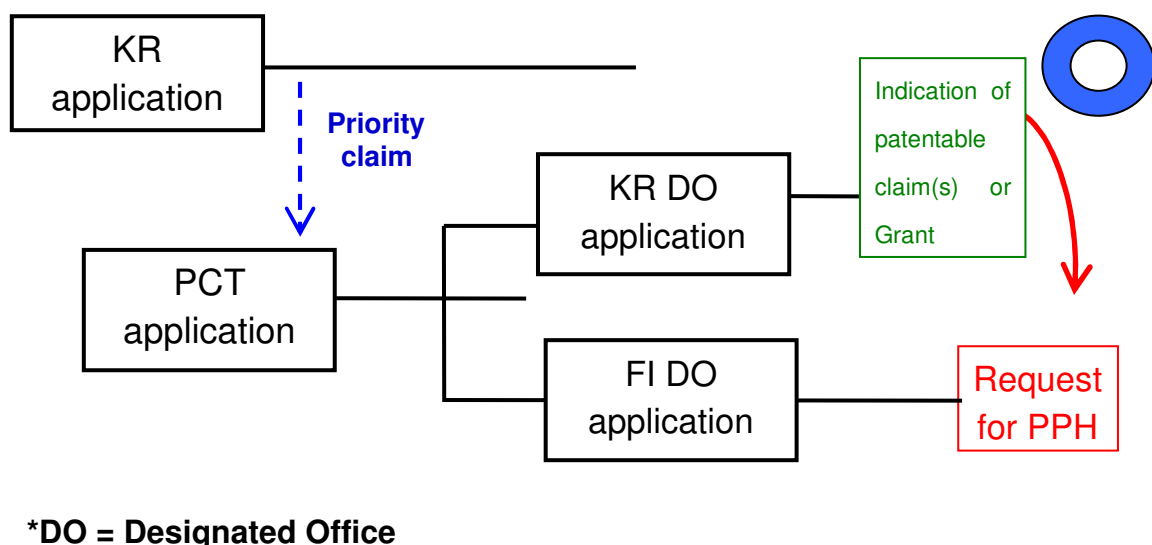

1.1.(3) The PCT national phase application where the PCT application has no priority claim

F Direct PCT Route

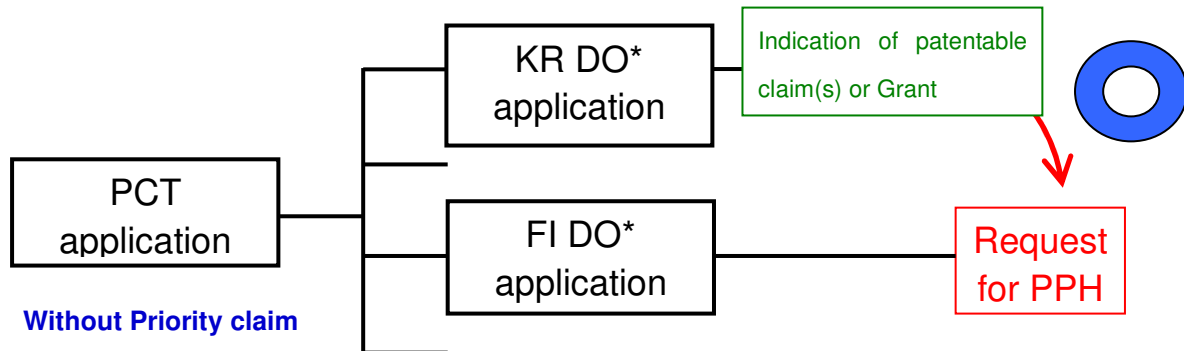

*DO = Designated Office

1.1.(4) The national application that validly claims priority under the Paris Convention from either a single PCT application with no priority claim or multiple PCT applications with no priority claims

G Direct PCT & Paris Route

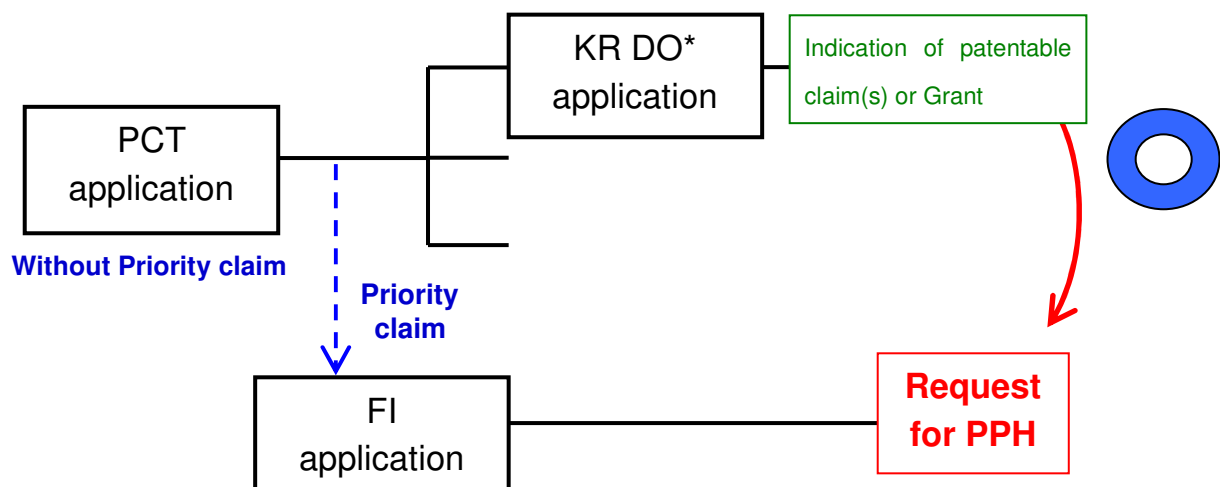

*DO = Designated Office

1.1.(5) The PCT national phase application where the PCT application validly claims priority from a PCT application which has no priority claims

H Direct PCT & PCT Route

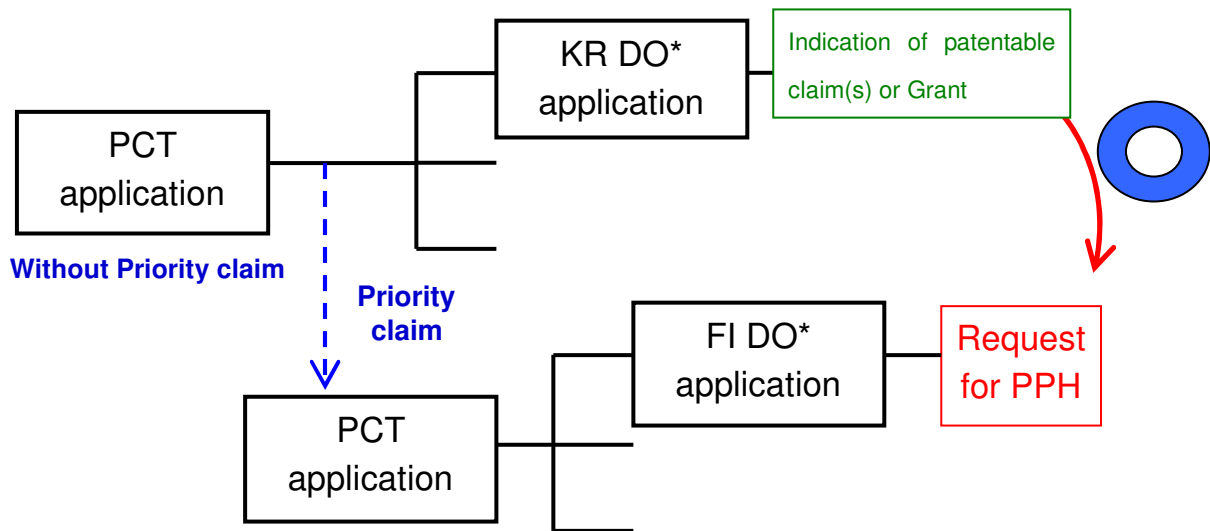

*DO = Designated Office

I Direct PCT & PCT Route

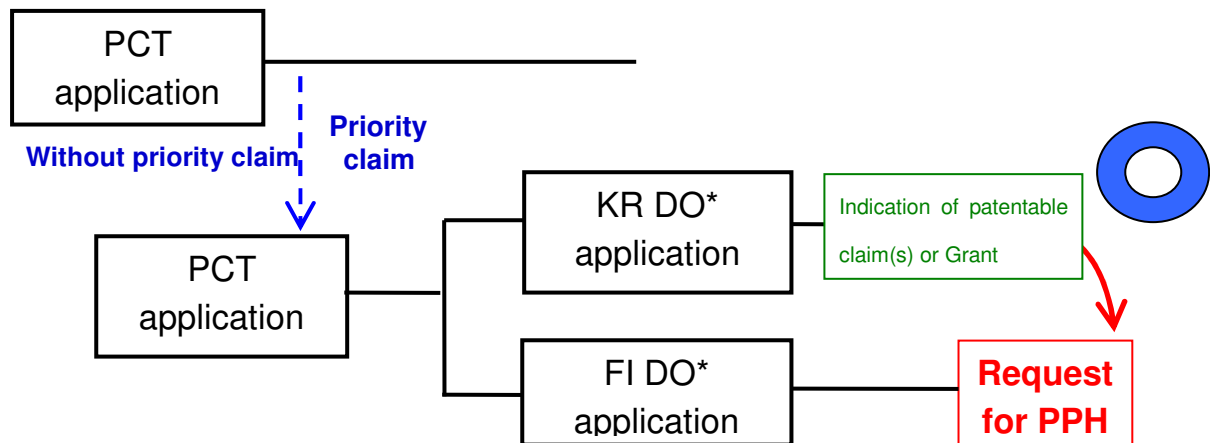

*DO = Designated Office

1.1.(6) The divisional application of an application as referred to in any of (1) to (5)

J Paris (PCT) Route (Divisional Application)

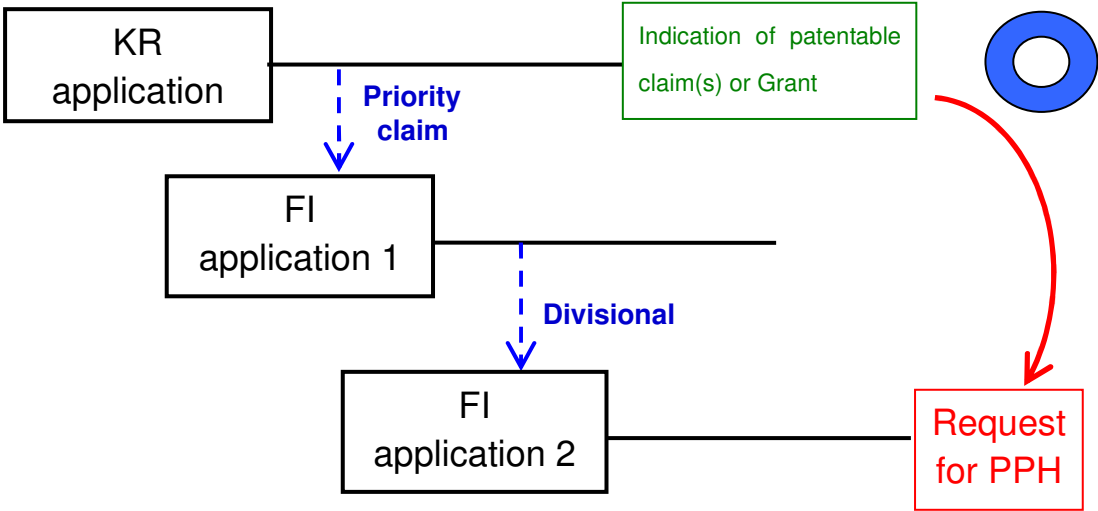

Cases NOT meeting requirement II.1.1

K

Paris Route

(But the first application is from the third country)

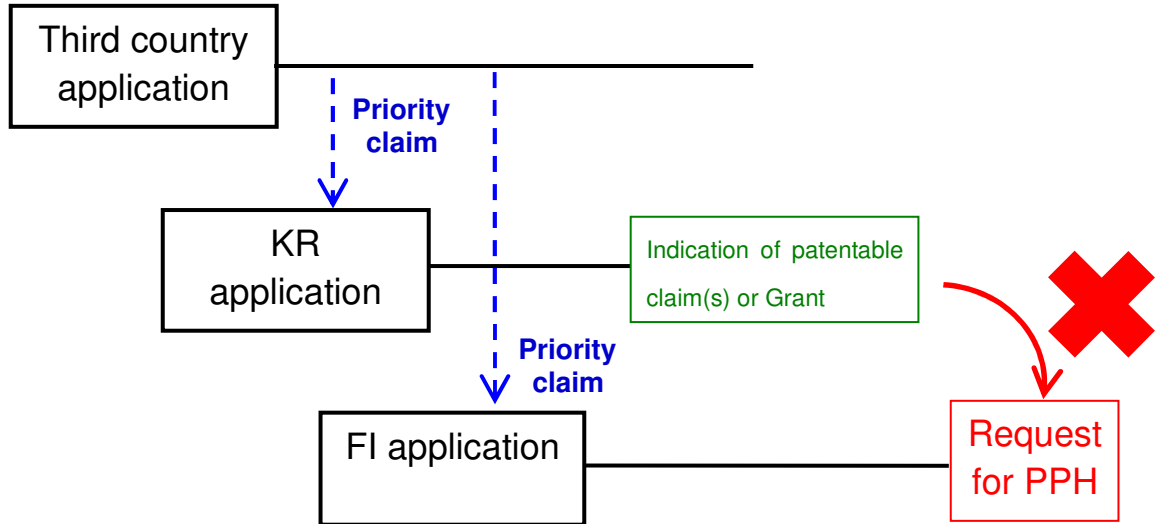

Third country: NOT PPH participating country

L

PCT route

(But the first application is from the third country)

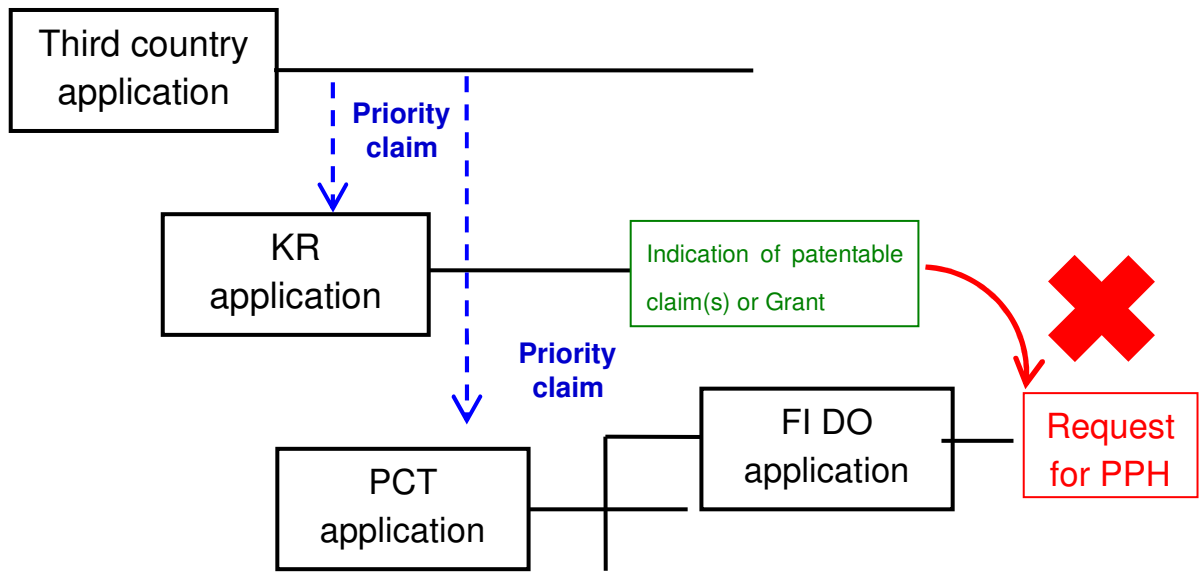

Third country: NOT PPH participating country

Cases NOT meeting requirement II.1.1 (continued)



PCT route
(But the first application is from the third country)

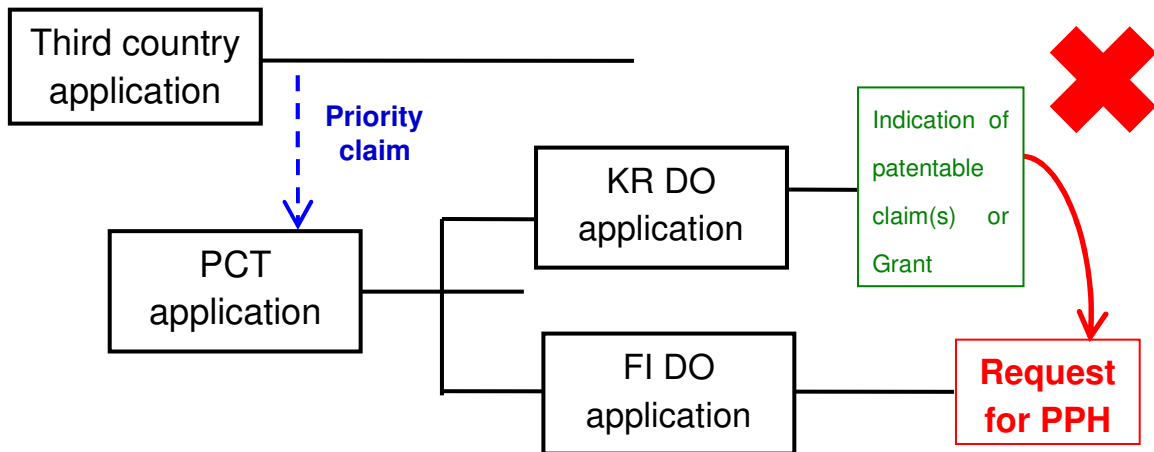

Third country: NOT PPH participating country