

Procedures to file a request to the JPO for Patent Prosecution Highway Program between the JPO and the USPTO

Part I

PPH using the national work products from the USPTO

Applicants can request accelerated examination for an application which is filed with the JPO, based on a corresponding USPTO application(s) having one or more claims that is/are determined to be patentable/allowable by the USPTO.

When an applicant files a request for an accelerated examination under the Patent Prosecution Highway (hereinafter called "PPH") based on the USPTO application to the Japan Patent Office (JPO), an applicant must submit a request form "The Explanation of Circumstances Concerning Accelerated Examination" based on the procedure prescribed in "the Guidelines of the Accelerated Examination and Appeal"¹.

Under the PPH program, an applicant is not required to fill in the section [2. the disclosure of prior arts and comparison between the claimed invention and prior art] in "The Explanation of Circumstances Concerning Accelerated Examination".

1. Requirements

- (a) Both the JPO application on which PPH is requested and the USPTO application(s) forming the basis of the PPH request shall have the same earliest date (whether this be a priority date or a filing date).

For example, the JPO application (including PCT national phase application) is either:

- (Case I) an application which validly claims priority under the Paris Convention to the USPTO application(s) (examples are provided in ANNEX I, Figure A, B, C and D), or
- (Case II) an application which is the basis of a valid priority claim under the Paris Convention for the USPTO application(s) (including PCT national phase application(s)) (examples are provided in ANNEX I, Figure E, F and G), or
- (Case III) an application which shares a common priority document with the USPTO application(s) (including PCT national phase application(s)) (examples are provided in ANNEX I, Figure H, I, J, K and L), or

¹ http://www.jpo.go.jp/torikumi/t_torikumi/souki/pdf/v3souki/guideline.pdf
"The Explanation of Circumstances Concerning Accelerated Examination" is described on pages 31-33.

(Case IV) a PCT national phase application where both the JPO application and the USPTO application(s) are derived from a common PCT international application having no priority claim (examples are provided in ANNEX I, Figure M),

(b) At least one corresponding application exists in the USPTO and has one or more claims that are indicated to be allowable/patentable in the latest office action by the USPTO.

The allowable/patentable claims are

- (i) The claims shown in the item of "The allowed claim(s) is/are ___" in "Notice of Allowability" or "Notice of Allowance and Fees Due";
- (ii) The claims shown in the item of "Claim(s) ___ is/are allowed" in "Office Action Summary" or "Non-Final Rejection" or "Final Rejection";
- (iii) The claims² shown in the item of "Claim(s) ___ is/are objected to" in "Office Action Summary" or "Non-Final Rejection" or "Final Rejection" and the USPTO examiner indicates that the claims are objected to as being dependent upon a rejected base claim, but would be allowable/patentable if rewritten in independent form including all of the limitations of the base claim and any intervening claims.

(Please refer to the **Example form** for the detail.)

(c) All claims on file as originally filed or as amended, for examination under the PPH must sufficiently correspond to one or more of those claims indicated as allowable in the USPTO.

Claims are considered to "sufficiently correspond" where, accounting for differences due to translations and claim format, the claims in the JPO are of the same or similar scope as the claims in the USPTO, or the claims in the JPO are narrower in scope than the claims in the USPTO.

In this regard, a claim that is narrower in scope occurs when an USPTO claim is amended to be further limited by an additional feature that is supported in the specification (description and/or claims).

A claim in the JPO which introduces a new/different category of claims to those claims indicated as allowable in the USPTO is not considered to

² When a claim is rejected and the USPTO examiner indicates in the Office action that certain features of the allowable/patentable invention have not been claimed and if properly claimed such claim may be given favorable consideration, the suggested and hypothetical claims are not regarded as allowable/patentable in this program.

sufficiently correspond. For example, the USPTO claims only contain claims to a process of manufacturing a product, then the claims in the JPO are not considered to sufficiently correspond if the JPO claims introduce product claims that are dependent on the corresponding process claims.

(d) The JPO has not begun examination of the application.

2. Documents to be submitted

Documents (a) to (d) below must be submitted by attaching to “The Explanation of Circumstances Concerning Accelerated Examination”.

Some of the documents may not be required to submit in certain cases. Please note that the name of the documents omitted to submit still have to be listed in “The Explanation of Circumstances Concerning Accelerated Examination” (Please refer to the **Example form** for the detail).

(a) Copies of all office actions in the USPTO³, which were sent for the corresponding application by the USPTO.

If these documents are available from Patent Application Information Retrieval (PAIR)⁴, the applicant does not have to submit them and only have to list up the name of the documents. The translations of the office actions are unnecessary.

The Japanese translation of office actions is basically unnecessary.

However, when the request is filed based on the U.S. claims shown in the item of “Claim(s) ___ is/are objected to”, it is required to submit translation of “Allowable Subject Matter” of the office action that shows claims are allowable/patentable except objection.

(b) Copies of all claims indicated to be allowable/patentable by the USPTO.

There is no need to submit a copy of claims, if they are available from the PAIR.

The translations of them are unnecessary.

(c) Copies of references cited by USPTO examiner

All of references cited in “Detailed Action” or “Reason for Allowance” must

³ e.g., “Non-Final Rejection”, “Final Rejection”, “Notice of Allowance and Fees Due”, and “Quayle”

⁴ <http://portal.uspto.gov/external/portal/pair/>

be submitted. If the references are patent documents, the applicant is not required to submit them. In case the JPO has difficulty in obtaining the documents, however, the applicant may be asked to submit them. Non-patent literature must always be submitted.

The translations of the references are unnecessary.

(d) Claim correspondence table

Applicant must submit a claim correspondence table which indicates how all claims in the JPO application sufficiently correspond to the allowable/patentable claims in the USPTO application.

When claims are identical or just literal translation, the applicant can just write down that “they are same” in the table. When claims are not just literal translation, it is necessary to explain the sufficient correspondence of each claim based on the criteria (1) (c) (Please refer to the **Example form**).

When the applicant has already submitted above documents (a) to (d) to the JPO through simultaneous or past procedures, the applicant may incorporate the documents by reference and does not have to attach them.

When the application doesn't fulfill the requirements 1 and 2, then the applicant cannot omit to fill in the section [2. the disclosure of prior arts and comparison between the claimed invention and prior art] and the request of accelerated examination is not accepted.

In that case, the JPO will notify that and the reason for it to the applicant (or the representative).

3. Example of “The Explanation of Circumstances Concerning Accelerated Examination” for filing request accelerated examination under PPH

(1) Circumstances

Please indicate the relationship between the JPO application on which PPH is requested and the corresponding USPTO application(s) from the aspect of the above Requirement 1.(a), and state that an accelerated examination is requested under the PPH program. The application number(s) of the corresponding USPTO application(s) must be specified. If the application requested for the PPH or the corresponding USPTO application(s) is a derived application (e.g., the USPTO application that is indicated to be allowable/patentable is a divisional application of a USPTO application which forms the basis of the priority claim of the JPO application), please indicate the application number of its basic application.

(2) Documents to be submitted

The applicant must list all required documents mentioned above 2. in an identifiable way, even when applicant omits to submit certain documents.

(3) Notice

Forms of “The Explanation of Circumstances Concerning Accelerated Examination” are different between on-line procedure and paper procedure. Please refer to the examples of forms when filling in (“Form 1 for Accelerated Examination” for on-line procedures, and “Form 2 for Accelerated Examination” for paper procedures.).

Example form of on-line procedures

<p>【書類名】 早期審査に関する事情説明書 ----- The name of this paper</p>		<p style="border: 1px solid orange; padding: 5px; display: inline-block;">Bibliographical items</p>
<p>【提出日】 平成00年00月00日 ----- Date of filing</p>		
<p>【あて先】 特許庁長官殿 ----- Destination</p>		
<p>【事件の表示】 【出願番号】 特願 0000-000000 ----- Application number</p>		
<p>【提出者】 【識別番号】 000000000 【住所又は居所】 〇〇県〇〇市〇丁目 【氏名又は名称】 〇〇〇〇 ----- The name and address of who submit this</p>		
<p>【代理人】 【識別番号】 000000000 【住所又は居所】 〇〇県〇〇市〇丁目 【氏名又は名称】 〇〇 〇〇 ----- The name and address of the attorney</p>		
<p>【早期審査に関する事情説明】 ----- The explanation of circumstances concerning accelerated examination</p>		
<p>1. 事情 本出願と米国特許商標庁への対応出願(出願番号00/000000)は、共に、英国知的財産庁への一つの出願(出願番号00/000000)に対してパリ条約に基づく優先権を有効に主張する出願であり、特許審査ハイウェイに基づく早期審査の申請を行う。</p>		
<p>----- 1. Circumstances Both this application and the corresponding USPTO application (the application number is 00/000000) validly claim priority under the Paris Convention to a UKIPO application (the application number is 00/000000), and the accelerated examination is requested under the PPH program.</p>		
<p>(提出を省略する物件) (物件名)**年**月**日付の対応米国出願に対するファースト・オフィス・アクションの写し (物件名)**年**月**日付の対応米国出願に対する特許許可通知の写し (物件名)対応米国出願の特許公報である米国特許第000000号公報 (物件名)対応米国出願に対して引用された米国特許第000000号公報 (物件名)対応米国出願に対して引用された日本国特許第000000号公報</p>		

List up the documents which can be omitted to submit

(Documents to be omitted to submit)
(The name of the document) Copy of the first office action in the USPTO on (date)
(The name of the document) Copy of notice of allowance in the USPTO on (date)
(The name of the document) United States Publication of the corresponding application 0000000
(The name of the document) Cited reference of the corresponding USPTO application: United States Publication of application 0000000
(The name of the document) Cited reference of the corresponding USPTO application: Japan Patent publication of application 0000000

以下において、「引用非特許文献1」とは、「村岡洋一著、「コンピュータサイエンス大学講座(第11巻)コンピュータ・アーキテクチャ」、第2版、株式会社近代科学者、1985年11月、p.123-127」である。

In what follows, “non-patent literature1” is “Yoichi Muraoka, Lecture of Computer Science (vol.11) computer architecture, 2nd edition, Scientist com, Nov. 1985, p.123-127.”

【提出物件の目録】

The list of submitted documents

【物件名】 米国出願と本出願の請求項の対応関係を示す書面 1

The table to explain how the claims indicated as allowable/patentable in the USPTO sufficiently correspond to the claims in the JPO application 1

【物件名】 引用非特許文献1 1

Non-patent literature1 1

List up the documents to be submitted

If the name of the document is long (over than 50 letters), it is impossible to write it down directly to the column “【物件名】.” Please write down the full name of the document in the column “【早期審査に関する事情説明】” and name it properly. Then write the name in the column “【物件名】.”

Use the same name as “【物件名】” under “【提出物件の目録】.”

Attach the document here as image file or text.

【添付物件】

The list of attached documents

【物件名】 米国出願と本出願の請求項の対応関係を示す書面

The table to explain how the claims indicated as allowable/patentable in the USPTO sufficiently correspond to the claims in the JPO application

【内容】

本出願の請求項	米国で特許可能とされた請求項	対応関係に関するコメント
The claim in the JPO	The allowable/patentable claim in the USPTO	Comments about the correspondence
1	1	両クレームは同一である。 Both claims are the same.
2	2	”
3	1	両クレームは、記載形式を除き同一である。 Both claims are the same except the claim format.
4	2	”
5	1	請求項5は、米国の請求項1にAという構成を付加したものである。 The claim 5 in the JPO has additional composition A on the Claim 1 in the USPTO

【物件名】 引用非特許文献1

Non-patent literature1

【内容】

Use the same name as “【物件名】” under “【提出物件の目録】.”

Attach the copy of the document.

Example form in case submitting translation of “Allowable Subject Matter” of the office action.

【早期審査に関する事情説明】

The explanation of circumstances concerning accelerated examination

1. 事情

1. Circumstances

...(中略)...

以下において、「オフィス・アクション1」とは、「**年**月**日付の米国におけるファースト・オフィス・アクションの「Allowable Subject Matter」の翻訳」である。

In what follows, “office action 1” is “the translation of “Allowable Subject Matter” of the first office.action in the USPTO on (date)”

【提出物件の目録】

The list of submitted documents

【物件名】 オフィス・アクション1 1

office action 1

⋮

⋮

【添付物件】

The list of attached documents

【物件名】 オフィス・アクション1

office action 1

【内容】

特許可能な主題

Allowable subject matter

請求項3は、拒絶されている基礎クレームに従属しているという不備があるが、基礎クレームと中間のクレームの全ての限定を含むように独立形式で書き直せば特許可能であろう。

Japanese translation of “allowable subject matter”

Note that in the case of paper procedure, the pendency period (the period between the request for PPH and the first office action) tends to be longer than on-line procedure.

Part II

PPH using the PCT international work products from the USPTO

Applicants can request accelerated examination by a prescribed procedure including submission of relevant documents on an application which is filed with the Japan Patent Office (JPO) and satisfies the following requirements under the JPO-USPTO Patent Prosecution Highway pilot programs based on PCT international work products (PCT-PPH pilot program).

When filing a request for the PCT-PPH pilot program, an applicant must submit a request form “The Explanation of Circumstances Concerning Accelerated Examination” based on the procedure prescribed in “the Guidelines of the Accelerated Examination and Appeal.”⁵ Under the PCT-PPH pilot program, an applicant is not required to fill in the section “2. the disclosure of prior arts and comparison between the claimed invention and prior art” in “The Explanation of Circumstances Concerning Accelerated Examination”.

The trial period of the PCT-PPH pilot program will commence on January 29, 2012, for a trial period duration of two years and ending on January 28, 2014.

The trial period may be extended if necessary until the USPTO and the JPO receive the sufficient number of PCT-PPH requests to adequately assess the feasibility of the PCT-PPH pilot program.

The Offices may also terminate the PCT-PPH pilot program early if the volume of participation exceeds manageable level, or for any other reason. Notice will be published if the PCT-PPH pilot program is terminated before January 28, 2014.

1. Requirements

The application which is filed with the JPO and on which the applicant files a request under the PCT-PPH must satisfy the following requirements:

- (1) The latest work product in the international phase of an international PCT application corresponding to the application (“international work product”), namely the Written Opinion of International Search Authority (WO/ISA), the Written Opinion of International Preliminary Examination Authority (WO/IPEA) or the International Preliminary Examination Report (IPER), indicates at least one claim as allowable/patentable (from the aspect of novelty, inventive steps and industrial applicability).

⁵ http://www.jpo.go.jp/torikumi/t_torikumi/souki/pdf/v3souki/guideline.pdf
“The Explanation of Circumstances Concerning Accelerated Examination” is described on pages 31-33.

Note that the ISA and the IPEA which produced the WO/ISA, WO/IPEA and the IPER must be the USPTO, but, if priority is claimed, the priority claim can be to an application in any Office, see example A' in Annex II (application ZZ can be any national application).

The applicant cannot file a request under PCT-PPH on the basis of an International Search Report (ISR) only.

In case any observation is described in Box VIII of WO/ISA, WO/IPEA or IPER which forms the basis of a PCT-PPH request, the applicant must identify and explain which claim(s) is/are patentable/allowable whether or not an amendment is submitted to correct the observation noted in Box VIII. The application will not be eligible for participating in PCT-PPH pilot program if the applicant does not identify and explain which claim(s) is/are patentable/allowable. In this regard, however, it does not affect the decision on the eligibility of the application whether the explanation is adequate and/or whether the amendment submitted overcomes the observation noted in Box VIII.

- (2) The relationship between the application and the corresponding international application satisfies one of the following requirements:
 - (A) The application is a national phase application of the corresponding international application. (See Diagrams A, A' and A'' in Annex II)
 - (B) The application is a national application as a basis of the priority claim of the corresponding international application. (See Diagram B in Annex II)
 - (C) The application is a national phase application of an international application claiming priority from the corresponding international application. (See Diagram C in Annex II)
 - (D) The application is a national application claiming priority from the corresponding international application. (See Diagram D in Annex II)
 - (E) The application is the derivative application (divisional application, application claiming domestic priority, etc.) of the application which satisfies one of the above requirements (A) – (D). (See Diagrams E1 and E2 in Annex II)
- (3) All claims on file, as originally filed or as amended, for examination under the PCT-PPH must sufficiently correspond to one or more of those claims indicated as allowable in the USPTO as ISA/IPEA.

Claims are considered to "sufficiently correspond" where, accounting for differences due to translations and claim format, the claims in the JPO are of the same or similar scope as the claims in the USPTO, or the claims in the JPO are narrower in scope than the claims in the USPTO.

In this regard, a claim that is narrower in scope occurs when an USPTO claim is amended to be further limited by an additional feature that is supported in the specification (description and/or claims).

A claim in the JPO which introduces a new/different category of claims to those claims indicated as allowable in the USPTO is not considered to sufficiently correspond. For example, the USPTO claims only contain claims to a process of manufacturing a product, then the claims in the JPO are not considered to sufficiently correspond if the JPO claims introduce product claims that are dependent on the corresponding process claims.

- (4) The JPO has not begun examination of the application.

2. Documents to be submitted

The applicant must submit the following documents attached to the request form in filing a request under PCT-PPH.

Some of the documents may not be required to submit in certain cases. Please note that the name of the documents omitted to submit still have to be listed in "The Explanation of Circumstances Concerning Accelerated Examination" (Please refer to the Example form for the detail).

- (1) A copy of the latest international work product which indicated the claims as allowable/patentable.

In case the application satisfies the relationship 1.(2)(A), the applicant need not submit a copy of the International Preliminary Report on Patentability (IPRP) because a copy of this document is already contained in the file-wrapper of the application. In addition, if the copy of the latest international work product is available via "PATENTSCOPE (registered trademark)"⁶, an applicant need not submit these documents, unless otherwise requested by the JPO.

(WO/ISA and IPER are usually available as "IPRP Chapter I" and "IPRP Chapter II" respectively in 30 months after the priority date.)

- (2) A copy of a set of claims which the latest international work product of the

⁶ <http://www.wipo.int/pctdb/en/index.jsp>

corresponding international application indicated as allowable/patentable.

If the copy of the set of claims which are indicated as allowable/patentable is available via "PATENTSCOPE (registered trademark)" (e.g. the international Patent Gazette has been published), an applicant need not submit this document, unless otherwise requested by the JPO.

- (3) A copy of references cited in the latest international work product of the international application corresponding to the application.

If the reference is a patent document, the applicant is not required to submit it . In case the JPO has difficulty in obtaining the document, however, the applicant may be asked to submit it.. Non-patent literature must always be submitted. Translations of cited documents are unnecessary.

- (4) A claims correspondence table which indicates how all claims in the application sufficiently correspond to the claims indicated to be allowable/patentable.

When claims are just literal translation, the applicant can just write down that "they are the same" in the table. When claims are not just literal translation, it is necessary to explain the sufficient correspondence of each claim based on the criteria 1. (3) (Please refer to the **Example form** below).

When an applicant has already submitted the above mentioned documents (1) - (4) to the JPO through simultaneous or past procedures, the applicant may incorporate the documents by reference and is thus not required to attach the documents.

3. Example of "The Explanation of Circumstances Concerning Accelerated Examination" for filing request accelerated examination under the PCT-PPH pilot program

- (1) Circumstances

The applicant must indicate that the relationship between the application and the corresponding international application satisfies one of the requirements (A) - (E) of the sub-section 1 (2), and the accelerated examination is requested under the PPH program. The application number(s) of the corresponding international application(s) also must be written.

In case any observation is described in Box VIII of WO/ISA, WO/IPEA or IPER which forms the basis of a PCT-PPH request, the applicant must identify and explain which claim(s) is/are patentable/allowable.

(2) Documents to be submitted

The applicant must list all required documents mentioned in the section 2 in an identifiable way, even when applicant omits to submit certain documents.

(3) Notice

Forms of “The Explanation of Circumstances Concerning Accelerated Examination” are different between on-line procedure and paper procedure. Please refer to the examples of forms when filling in (“Form 1 for Accelerated Examination” for on-line procedures, and “Form 2 for Accelerated Examination” for paper procedures.).

Example form of on-line procedures

<p>【書類名】 早期審査に関する事情説明書 ----- The name of this paper</p>		
<p>【提出日】 平成00年00月00日 ----- Date of filing</p>		
<p>【あて先】 特許庁長官殿 ----- Destination</p>		
<p>【事件の表示】 【出願番号】 特願 0000-000000 ----- Application number</p>		
<p>【提出者】 【識別番号】 000000000 【住所又は居所】 〇〇県〇〇市〇丁目 【氏名又は名称】 〇〇〇〇 ----- The name and address of who submit this</p>		
<p>【代理人】 【識別番号】 000000000 【住所又は居所】 〇〇県〇〇市〇丁目 【氏名又は名称】 〇〇 〇〇 ----- The name and address of the attorney</p>		
<p>【早期審査に関する事情説明】 ----- The explanation of circumstances concerning accelerated examination</p>		
<p>1. 事情 本出願は国際出願(出願番号 PCT/US0000/000000)の国内移行出願であり、特許審査ハイウェイに基づく早期審査の申請を行うものである。 当該国際出願について国際調査機関としての米国特許商標庁が作成した見解書において、特許請求の範囲に対し特許可能との判断が明示されている。</p>		
<p>1. Circumstances This application is a national phase application of a PCT international application (the application number is PCT/US0000/000000), and the accelerated examination is requested under the PPH program. The WO/ISA issued by the USPTO as an ISA indicates at least one claim as patentable.</p>		
<p>(提出を省略する物件) (物件名)**年**月**日付の対応国際出願に対する WO/ISA の写し (物件名)対応国際出願の国際公開公報である国際公開第0000/000000号 (物件名)対応国際出願に対して引用された米国特許第000000号公報 (物件名)対応国際出願に対して引用された日本国特許第000000号公報</p>		

List up the documents which can be omitted to submit

(Documents to be omitted to submit)
(The name of the document) Copy of WO/ISA on (date)
(The name of the document) International publication of the corresponding PCT international application: WO 0000/000000
(The name of the document) Cited reference of the corresponding PCT international application: United States Publication of application 0000000
(The name of the document) Cited reference of the corresponding PCT international application: Japan Patent publication of application 0000000

以下において、「引用非特許文献1」とは、「村岡洋一著、「コンピュータサイエンス大学講座(第11巻)コンピュータ・アーキテクチャ」、第2版、株式会社近代科学者、1985年11月、p.123-127」である。

In what follows, “non-patent literature1” is “Yoichi Muraoka, Lecture of Computer Science (vol.11) computer architecture, 2nd edition, Scientist com, Nov. 1985, p.123-127.”

【提出物件の目録】

The list of submitted documents

【物件名】 国際出願と本出願の請求項の対応関係を示す書面 1

The table to explain how the claims indicated as patentable in the international phase sufficiently correspond to the claims in the JPO application 1

【物件名】 引用非特許文献1 1

Non-patent literature1 1

List up the documents to be submitted

If the name of the document is long (over than 50 letters), it is impossible to write it down directly to the column “【物件名】.” Please write down the full name of the document in the column “【早期審査に関する事情説明】” and name it properly. Then write the name in the column “【物件名】.”

Use the same name as “【物件名】” under “【提出物件の目録】.”

Attach the document here as image file or text.

【添付物件】

The list of attached documents

【物件名】 国際出願と本出願の請求項の対応関係を示す書面

The table to explain how the claims indicated as patentable in the international phase sufficiently correspond to the claims in the JPO application

【内容】

本出願の請求項	国際段階で特許可能とされた請求項	対応関係に関するコメント
The claim in the JPO	The patentable claim in the international phase	Comments about the correspondence
1	1	両クレームは同一である。 Both claims are the same.
2	2	”
3	1	両クレームは、記載形式を除き同一である。 Both claims are the same except the claim format.
4	2	”
5	1	請求項 5 は、国際段階の請求項 1 に A という構成を付加したものである。 The claim 5 in the JPO has additional composition A on the Claim 1 in the international phase.

【物件名】 引用非特許文献1

Non-patent literature1

【内容】

Attach the copy of the document.

Use the same name as “【物件名】” under “【提出物件の目録】.”

Note that in the case of paper procedure, the pendency period (the period between the request for PPH and the first office action) tends to be longer than on-line procedure.

A

(Case I)
- Paris route -

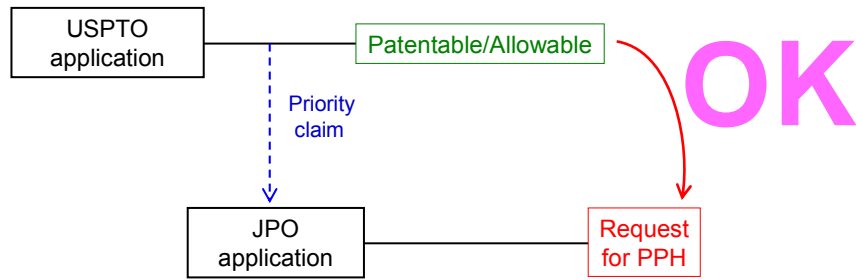

B

(Case I)
- PCT route -

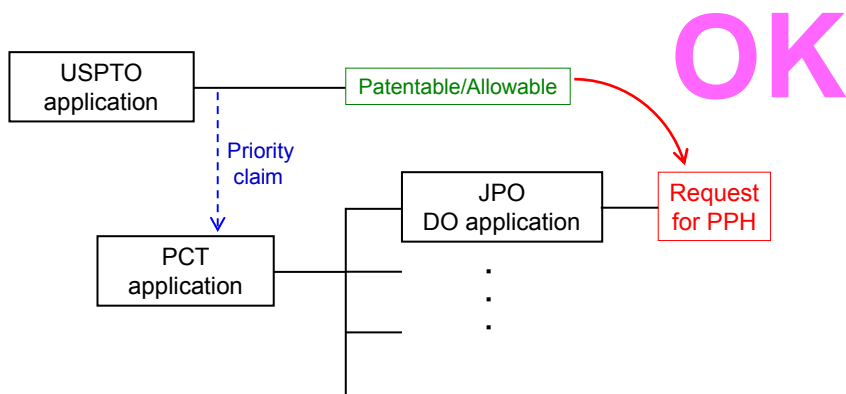

C

(Case I)
- Paris route & Complex priority -

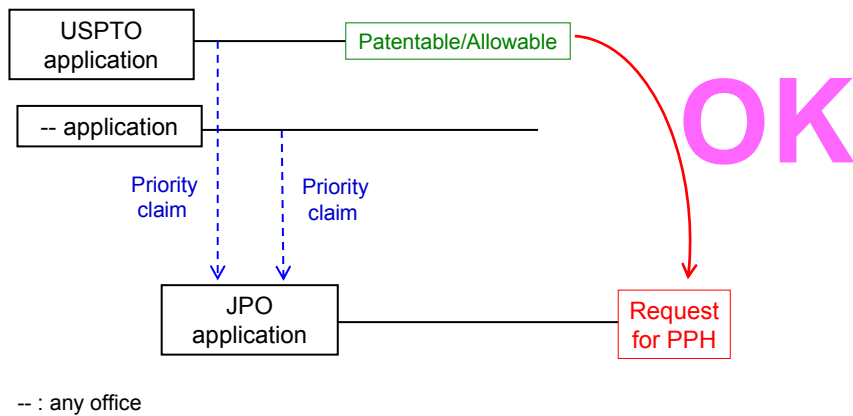

D

(Case I)
- Paris route & divisional application -

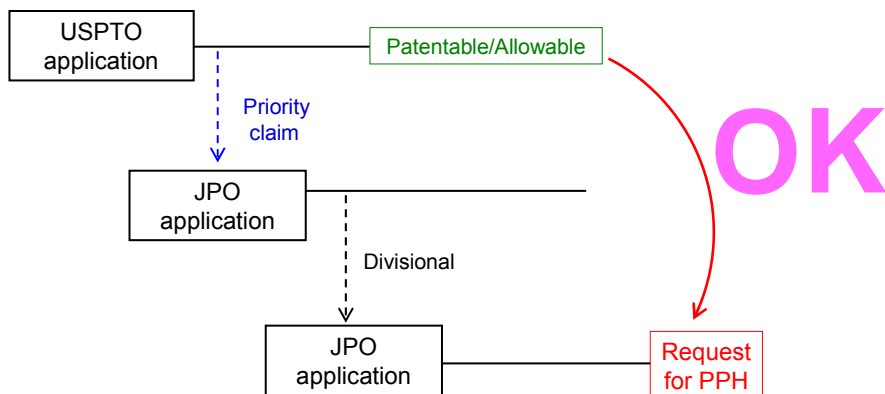

E

(Case II)
- Paris route -

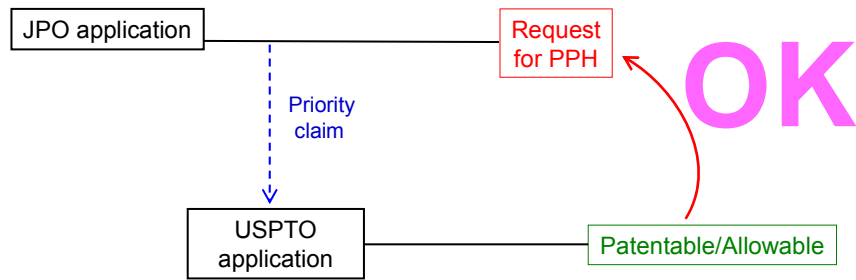

F

(Case II)
- PCT route -

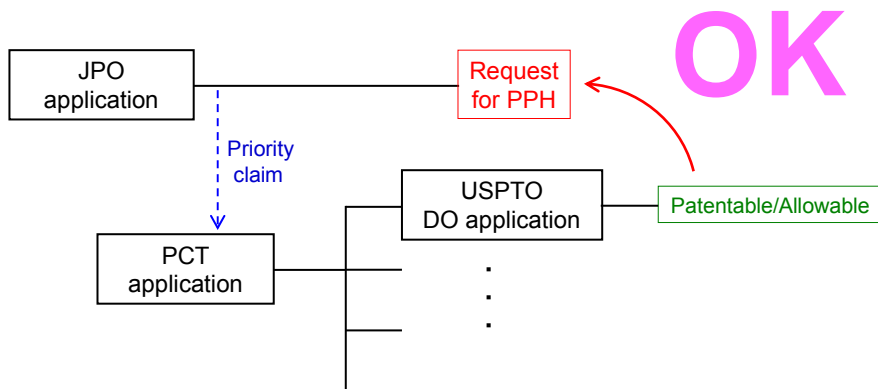

G

(Case II)
- Paris route & Complex priority -

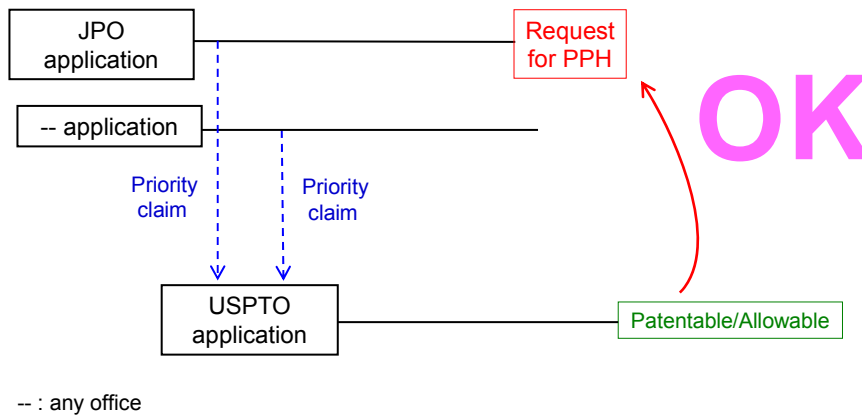

H

(Case III)
- Paris route, Provisional application -

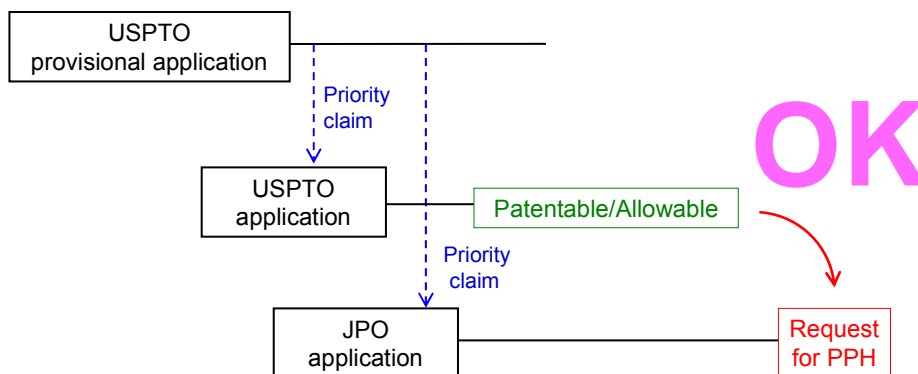

I

(Case III)

- Paris route, but the first application is from the third country -

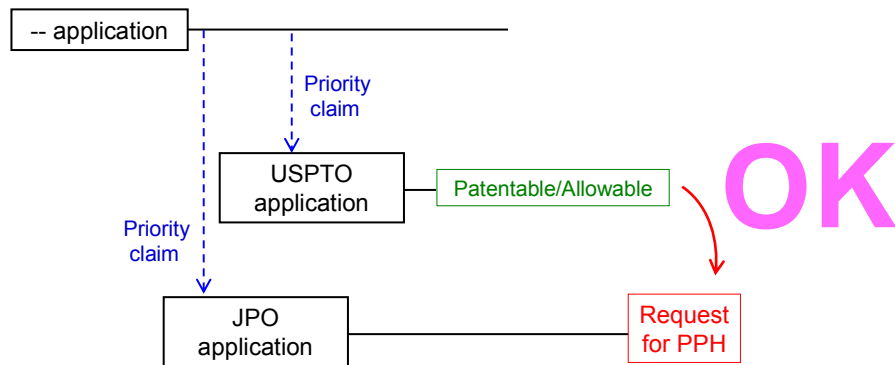

-- : the office other than the JPO and the USPTO

J

(Case III)

- PCT route, but the first application is from the third country -

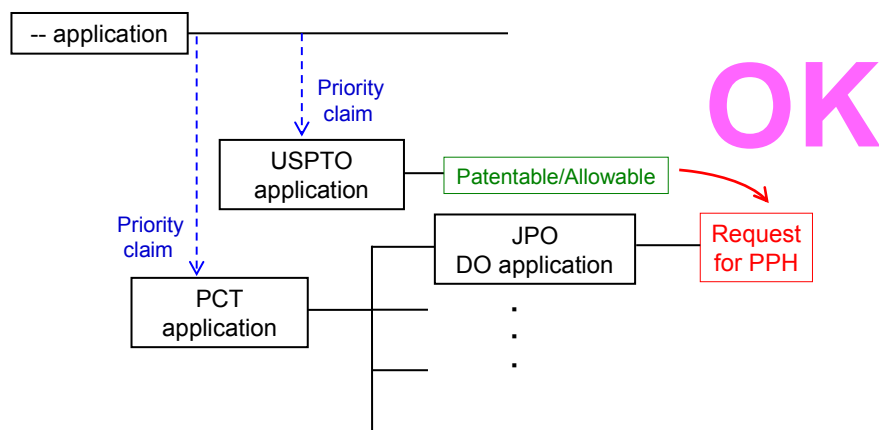

-- : the office other than the JPO and the USPTO

K

(Case III)
- PCT route -

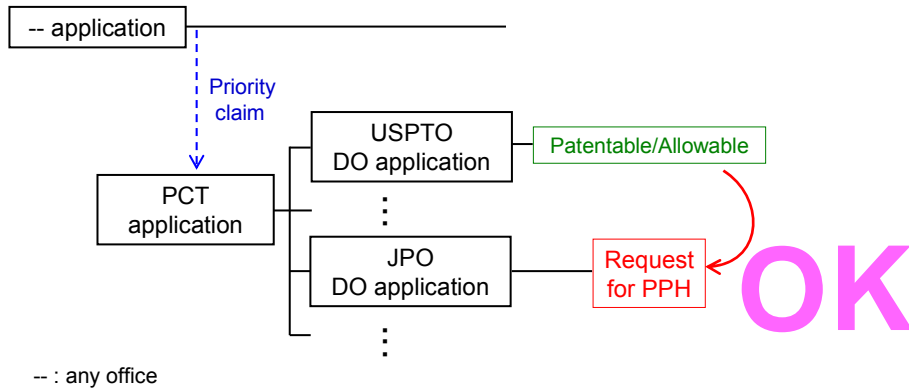

L

(Case III)
- Direct PCT & PCT route -

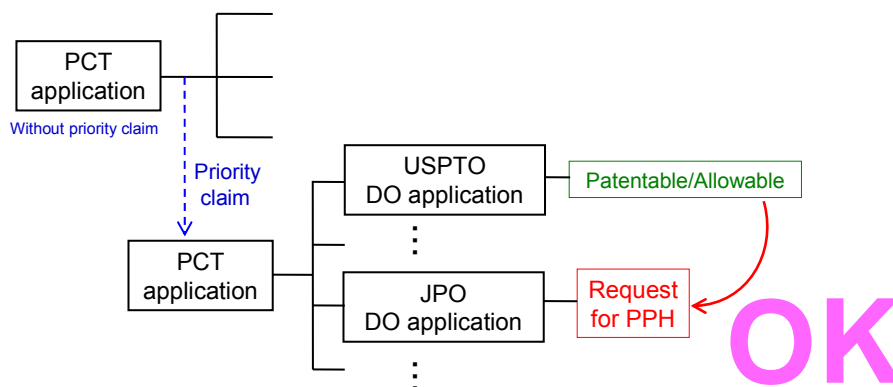

M

(Case IV)
- Direct PCT route -

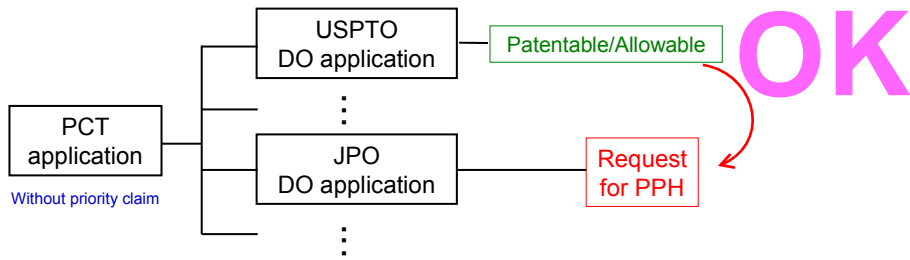

(A) The application is a national phase application of the corresponding international application.

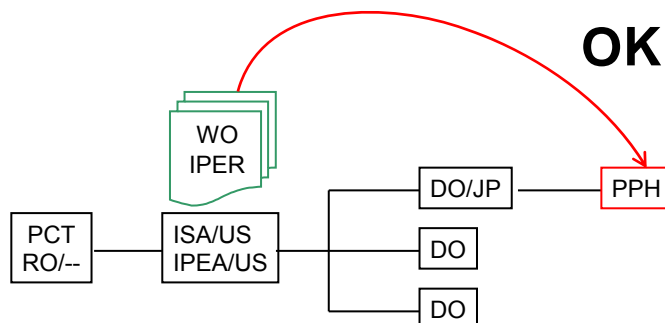

(A') The application is a national phase application of the corresponding international application.

(The corresponding international application claims priority from a national application.)

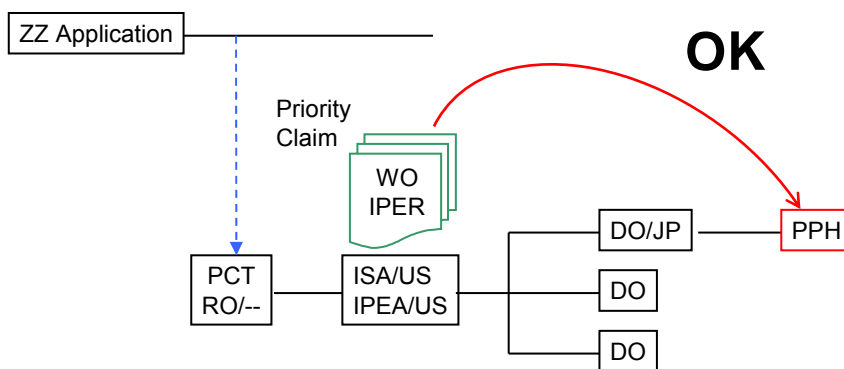

ZZ=any office

(A'') The application is a national phase application of the corresponding international application.

(The corresponding international application claims priority from an international application.)

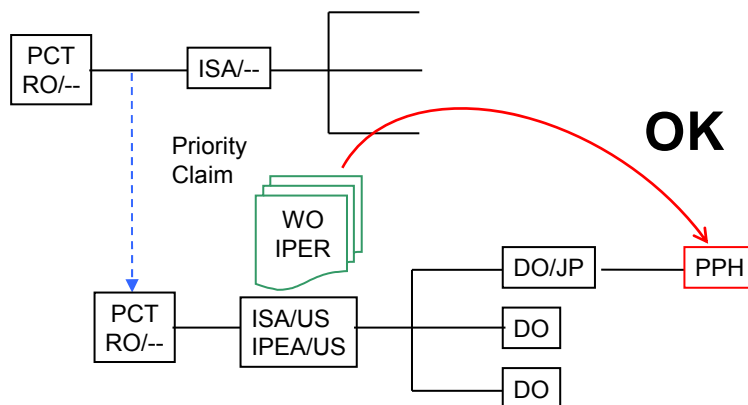

(B) The application is a national application as a basis of the priority claim of the corresponding international application.

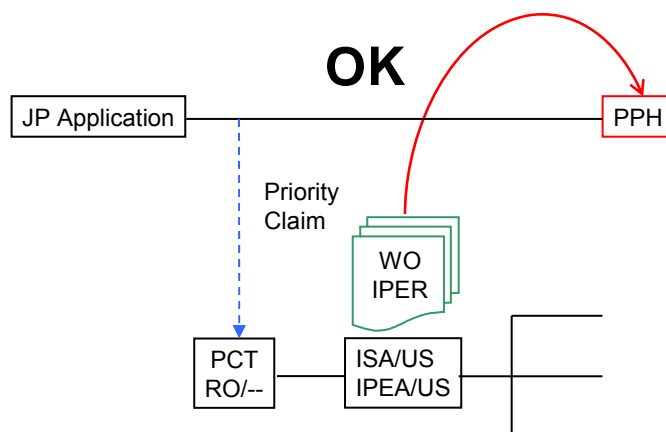

(C) The application is a national phase application of an international application claiming priority from the corresponding international application.

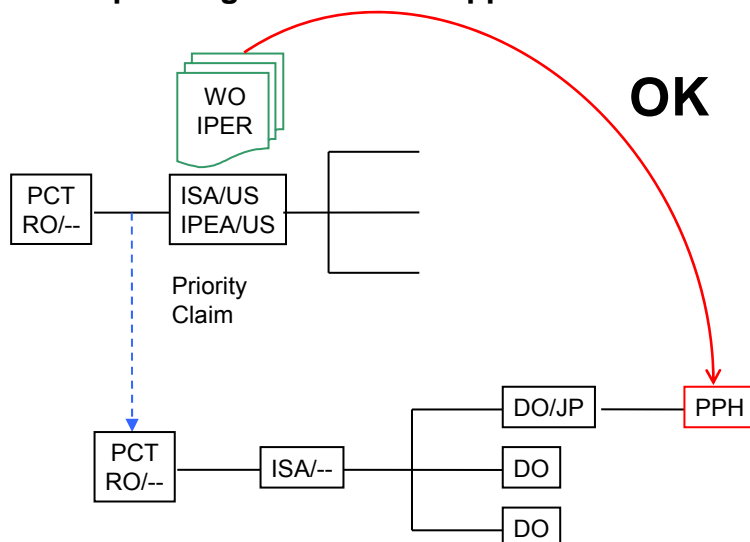

(D) The application is a national application claiming foreign/domestic priority from the corresponding international application.

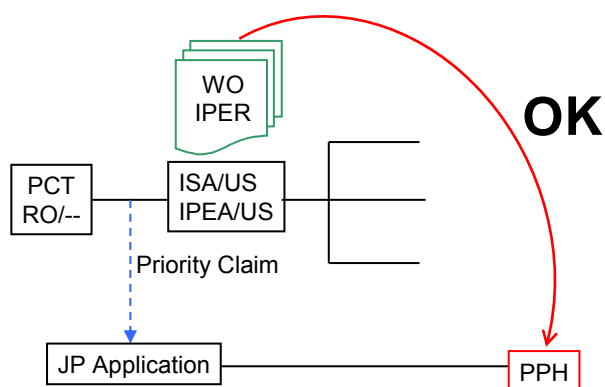

(E1) The application is a divisional application of an application which satisfies the requirement (A).

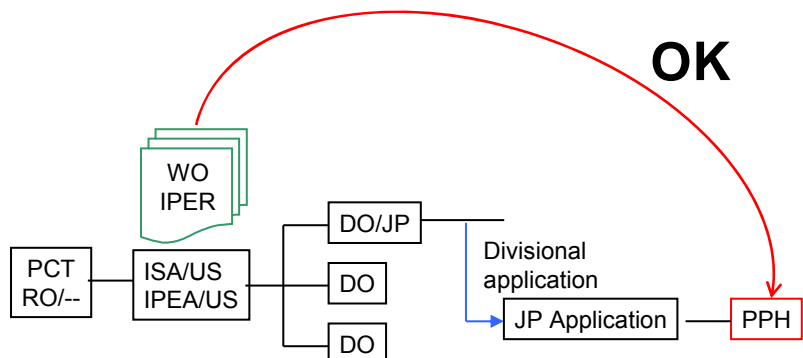

(E2) The application is an application claiming domestic priority from an application which satisfies the requirement (B).

