

Procedures to File a Request to the Korean Intellectual Property Office for Patent Prosecution Highway Pilot Program between the Korean Intellectual Property Office and the United States Patent and Trademark Office based on Patent Cooperation Treaty Work Products

The trial period of this Patent Prosecution Highway based on the Patent Cooperation Treaty Work Products (PCT-PPH) pilot program will commence on July 1, 2011 and will end on May 31, 2012. The trial period may be extended if necessary until the Korean Intellectual Property Office (KIPO) and the United States Patent and Trademark Office (USPTO) receive the sufficient number of PCT-PPH requests to adequately assess the feasibility of the PCT-PPH pilot program.

The Offices may also terminate the PCT-PPH pilot program if the volume of participation exceeds manageable level, or for any other reason. Ex Ante notice will be published if the PCT-PPH pilot program is terminated.

Applicants can request accelerated examination by a prescribed procedure including submission of relevant documents on an application which is filed with the KIPO and satisfies the following requirements under the KIPO-USPTO Patent Prosecution Highway pilot program based on PCT international work products (PCT-PPH pilot program).

When filing a request for the PCT-PPH pilot program, an applicant must submit a request form "Request for Accelerated Examination under the PCT-PPH" to the KIPO.

1. Requirements

The application which is filed with the KIPO and on which the applicant files a request for the PCT-PPH must satisfy the following requirements:

- (a) *The latest work product in the international phase of a PCT application corresponding to the application ("international work product"), namely the Written Opinion of International Search Authority (WO/ISA), the Written Opinion of International Preliminary Examination Authority (WO/IPEA) or the International Preliminary Examination Report (IPER), indicates at least one claim as patentable/allowable (from the aspect of novelty, inventive steps and industrial applicability).***

Note that the ISA and the IPEA which produced the WO/ISA, WO/IPEA and the IPER are limited to the KIPO or the USPTO, but, if priority is claimed, the priority claim can be to an application in any Office, see example A' in Annex I (application ZZ can be any national

application).

The applicant cannot file a request for PCT-PPH on the basis of an International Search Report (ISR) only.

In case any observation is described in Box VIII of WO/ISA, WO/IPEA or IPER which forms the basis of a PCT-PPH request, the applicant must explain why the claim(s) is/are not subject to the observation irrespective of whether or not an amendment is submitted to correct the observation noted in Box VIII. The application will not be eligible for participating in PCT-PPH pilot program if the applicant does not explain why the claim(s) is/are not subject to the observation. In this regard, however, it does not affect the decision on the eligibility of the application whether the explanation is adequate and/or whether the amendment submitted overcomes the observation noted in Box VIII.

- (b) *The relationship between the application and the corresponding international application satisfies one of the following requirements:***
- (i) *The application is a national phase application of the corresponding international application. (See Figures A, A', and A'' in Annex I)***
 - (ii) *The application is a national application as a basis of the priority claim of the corresponding international application. (See Figure B in Annex I)***
 - (iii) *The application is a national phase application of an international application claiming priority from the corresponding international application. (See Figure C in Annex I)***
 - (iv) *The application is a national application claiming foreign/domestic priority from the corresponding international application. (See Figure D in Annex I)***
 - (v) *The application is the derivative application (divisional application and application claiming domestic priority etc.) of the application which satisfies one of the above requirements (i) – (iv). (See Figures E1 and E2 in Annex I)***
- (c) *All claims on file, as originally filed or as amended, for examination under the PCT-PPH must sufficiently correspond to one or more of those claims indicated to be patentable/allowable in the latest international work product of the corresponding international application.***

Claims are considered to "sufficiently correspond" where, accounting for differences due to translations and claim format, the claims of the application are of the same or similar scope as the claims indicated to be patentable/allowable in the latest international work product, or the claims of the application are narrower in scope than the claims indicated to be patentable/allowable in the latest international work product.

In this regard, a claim that is narrower in scope occurs when a claim indicated to be patentable/allowable in the latest international work product is amended to be further

limited by an additional feature that is supported in the specification (description and/or claims) of the application.

A claim of the application which introduces a new/different category of claims to those claims indicated to be patentable/allowable in the latest international work product is not considered to sufficiently correspond. For example, the claims indicated to be patentable/allowable in the latest international work product only contain claims to a process of manufacturing a product, then the claims of the application are not considered to sufficiently correspond if the claims of the application introduce product claims that are dependent on the corresponding process claims.

It is not necessary to include “all” claims determined to be patentable/allowable in the corresponding international application in an application in the KIPO (the deletion of claims is allowable). For example, in the case where the corresponding international application contains 5 claims determined to be patentable/allowable, the application in the KIPO may contain only 3 of these 5 claims.

Refer to Annex II for the cases which are considered to “sufficiently correspond” and the cases which are not considered to “sufficiently correspond”.

Any claims amended or added after the grant of the request for participation in the PCT-PPH pilot program need to sufficiently correspond to the claims indicated as patentable/allowable in the latest international work product.

(d) A “Request for Examination” must have been filed.

The request for accelerated examination under the PCT-PPH must be accompanied by, or preceded by a request for examination.

The request for accelerated examination under the PCT-PPH may be filed not only when examination has not begun, but also when examination has already begun.

2. Documents to be submitted

The applicant must submit the following documents attached to the request form in filing a request for PCT-PPH. Some of the documents may not be required to submit in certain cases.

(a) A copy of the latest international work product which indicated the claims to be patentable/allowable and their Korean or English translations.

If the copy of the latest international work product is available via “PATENTSCOPE”¹, an applicant need not submit these documents, unless otherwise requested by the KIPO.

If it is impossible for the examiner to understand the translated international work product,

¹ <http://www.wipo.int/pctdb/en/index.jsp>

the examiner can request the applicant to resubmit translations.

(b) A copy of a set of claims which the latest international work product of the corresponding international application indicated to be patentable/allowable and their Korean or English translations.

If the copy of the set of claims which are indicated to be patentable/allowable is available via "PATENTSCOPE" (e.g. the international Patent Gazette has been published), an applicant need not submit this document unless otherwise requested by the KIPO.

If it is impossible for the examiner to understand the translated claims, the examiner can request the applicant to resubmit translations.

(c) A copy of references cited in the latest international work product of the international application corresponding to the application.

Documents which are only referred to as references and consequently do not consist of the reasons for refusal do not have to be submitted.

If the reference is a patent document, the applicant is not required to submit it. In case the KIPO has difficulty in obtaining the document, however, the applicant may be asked to submit it. Non-patent literature must always be submitted. Translations of cited references are unnecessary.

(d) A claims correspondence table which indicates how all claims in the application sufficiently correspond to the claims indicated to be patentable/allowable.

When claims are just literal translation, the applicant can just write down that "they are the same" in the table. When claims are not just literal translation, it is necessary to explain the sufficient correspondence of each claim based on the criteria 1.(c) (Please refer to the Example form below).

When an applicant has already submitted the above mentioned documents (a) - (d) to the KIPO through simultaneous or past procedures, the applicant may incorporate the documents by reference and is thus not required to attach the documents.

3. Example of "Request for Accelerated Examination under the PCT-PPH" for filing request for an accelerated examination under the PCT-PPH pilot program

(a) Circumstances

The applicant must indicate that the application is included in (i) to (v) of 1.(b), and that the accelerated examination is requested under the PCT-PPH pilot program. The application number(s) of the corresponding international application(s) also must be written.

In case any observation is described in Box VIII of WO/ISA, WO/IPEA or IPER which forms the basis of a PCT-PPH request, the applicant must explain why the claim(s) is/are not subject to the observation.

(b) Documents to be submitted

The applicant must list all required documents mentioned above 2. in an identifiable way, even when applicant omits to submit certain documents.

(c) Notice

Please refer to the example of the form of "Request for Accelerated Examination under the PCT-PPH".

4. Procedure for the accelerated examination under the PCT-PPH pilot program

The KIPO decides whether the application can be entitled to the status for an accelerated examination under the PCT-PPH when it receives a request with the documents stated above. When the KIPO decides that the request is acceptable, the application is assigned a special status for an accelerated examination under the PCT-PPH.

In those instances where the request does not meet all the requirements set forth above, the applicant will be notified and the defects in the request will be identified. The applicant will be given opportunity to perfect the request. If not perfected, the applicant will be notified and the application will await action in its regular turn. Then the applicant may resubmit the request.

The KIPO will not notify the applicant of the acceptance for assigning a special status for accelerated examination under the PCT-PPH, but instead applicant may recognize it by the reception of an office action resulting from accelerated examination.

**Example form of Request for Accelerated Examination under the PCT-PPH (consists of 2 Forms:
Request for Accelerated Examination and Explanation of Request for Accelerated Examination
under the PCT-PPH)**

【서류명】 심사청구(우선심사신청)서 (Form of Request for Accelerated Examination)

【구분】 우선심사신청 (Request for Accelerated Examination)

【제출인】 (Subscriber)

【명칭】 (Name)

【출원인코드】 (Subscriber ID)

【사건과의 관계】 (Relation)

【대리인】 (Agent)

【성명】 (Name)

【대리인코드】 (Agent ID)

【포괄위임등록번호】 (Mandating Registration ID)

【사건의 표시】 (Application)

【출원번호】 (Application Number)

【발명의 명칭】 (Title)

【수수료】 (Fee)

【우선심사 신청료】 (Fee for Accelerated Examination)

【수수료 자동납부번호】 (Automated Fee Transfer ID)

【취지】 (Purpose)

【첨부서류】

(Attachment, Explanation of Request for Accelerated Examination under the PCT-PPH)

【서류명】 PCT-PPH 에 의한 우선심사신청설명서

(Explanation of Request for Accelerated Examination under the PCT-PPH)

【대상국가】 (Office of First Filing)

【본원출원번호】 (Application Number)

【대응출원번호】 (Application Number of Corresponding Application)

【본원출원과 대응출원의 관계】 (Relation of the Corresponding Application)

【제출서류】 (Required Documents)

【신규성, 진보성 및 산업상 이용가능성이 모두 있다고 판단된 특허청구범위】

(Patentable Claims in view of Novelty, Inventive step and Industrial Applicability)

【서류명 및 제출(발행)일】 (Issue Date)

【서류제출여부】 (Submit, Y/N)

【제출생략 이유】 (Reasons of Exemption)

【번역문제출여부】 (Submit Translations, Y/N)

【제출생략 이유】 (Reasons of Exemption for Translations)

【국제조사 또는 국제예비심사 관련 통지서】 (International Work Product)

【서류명 및 통지일】 (Issue Date)

【서류제출여부】 (Submit, Y/N)

【제출생략 이유】 (Reasons of Exemption)

【번역문제출여부】 (Submit Translations, Y/N)

【제출생략 이유】 (Reasons of Exemption for Translations)

【국제조사 또는 국제예비심사에서 인용된 선행기술문헌】 (Prior Arts cited in WO/IPER)

【명칭】 (Title)

【제출여부】 (Submit, Y/N)

【제출생략 이유】 (Reasons of Exemption)

【청구항간 대응관계설명표】 (Claim Correspondence Table)

본원출원의 청구항 번호 (Claim Number)	대응출원에서 특허가능하다고 판단한 청구항 번호 (Claim Number of the Corresponding International Application)	대응관계 설명 (Correspondence)

【국제출원에 관한 의견 관련 설명】

(Explanation for the Comments in Box VIII of the International Work Product)

ANNEX I

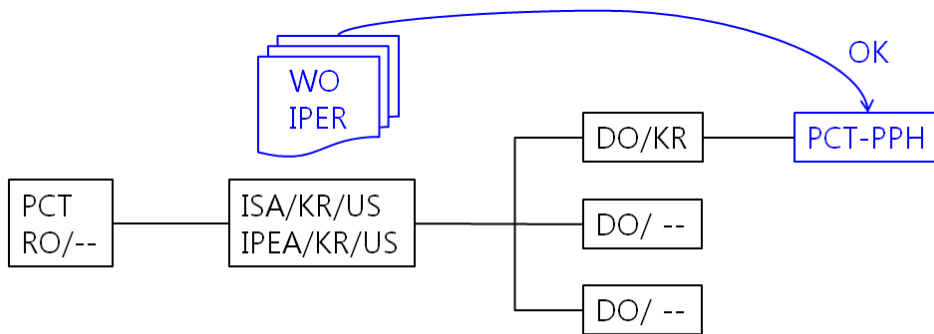

(A) The application is a national phase application of the corresponding PCT application.

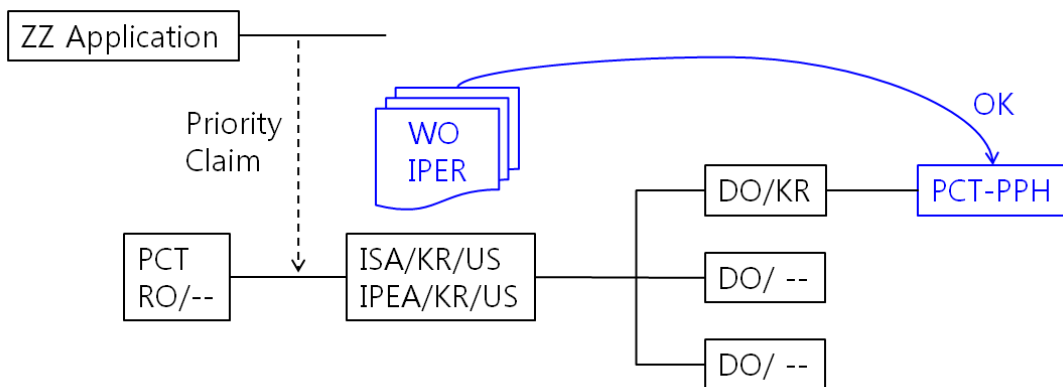

(A) The application is a national phase application of the corresponding PCT application.
(The corresponding PCT application claims priority to a national application filed anywhere.)

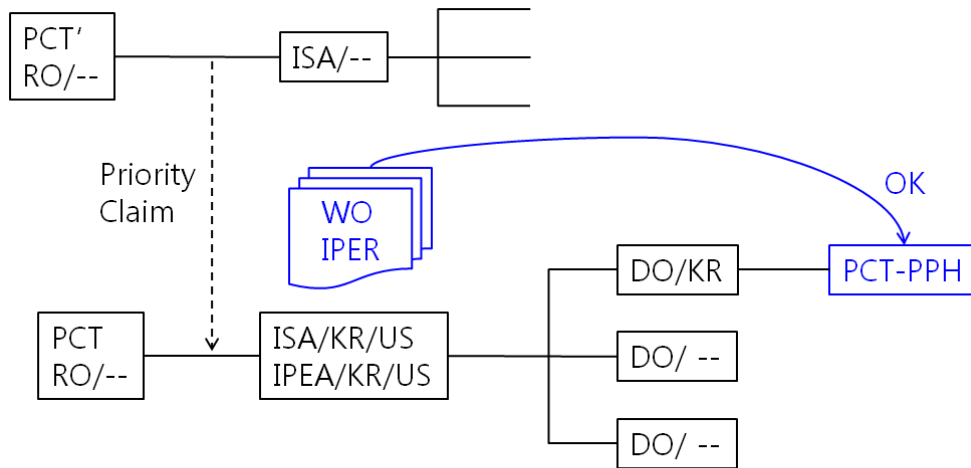

(A') The application is a national phase application of the corresponding PCT application claiming priority to another PCT application.

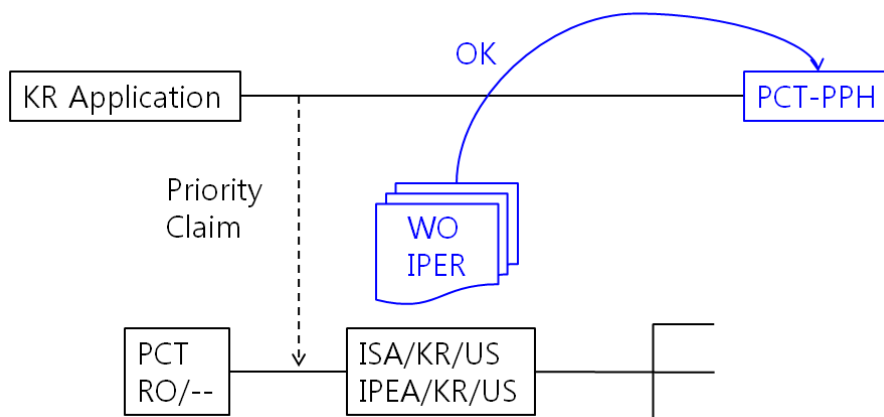

(B) The application is a national application which forms the basis of the priority claim of the corresponding PCT application.

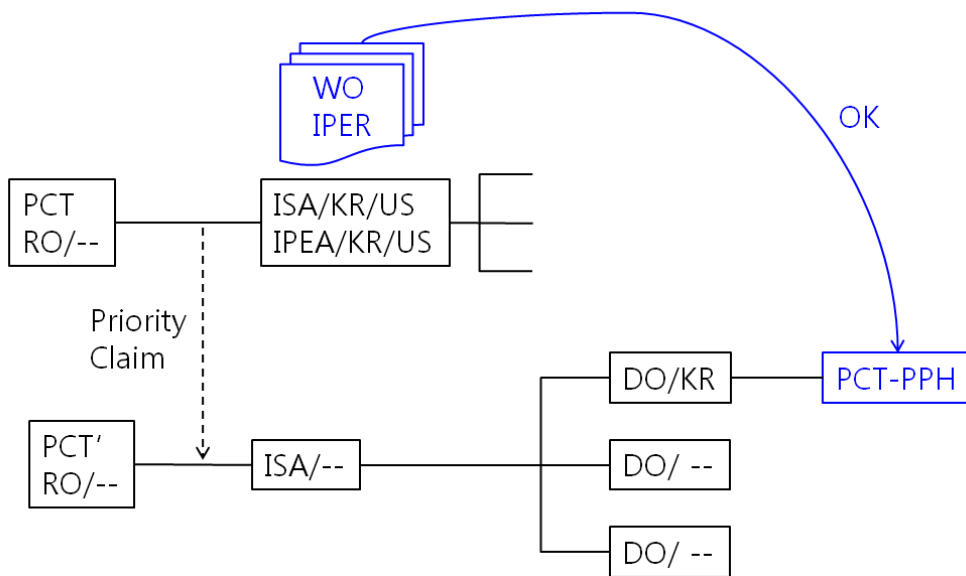

(C) The application is a national phase application of a PCT application claiming priority to the corresponding PCT application.

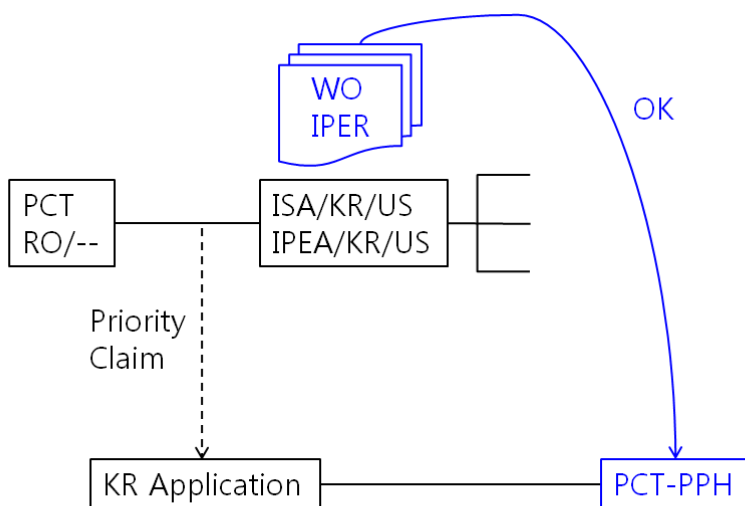

(D) The application is a national application claiming foreign/domestic priority to the corresponding PCT application.

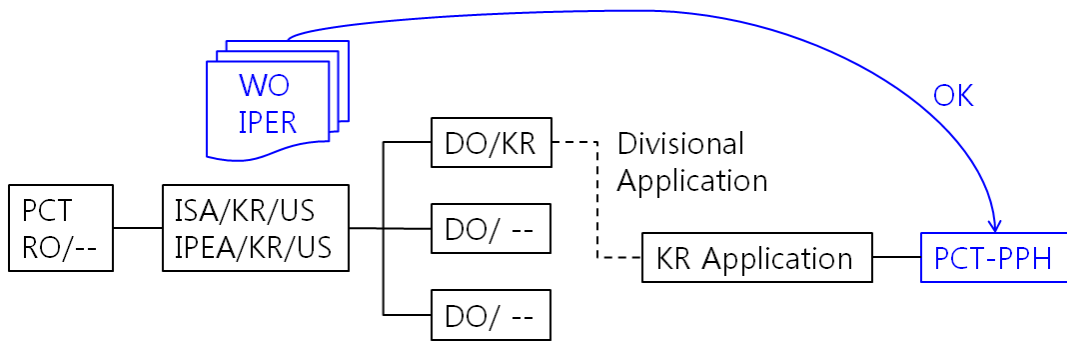

(E1) The application is a divisional application of an application which satisfies the requirement (A).

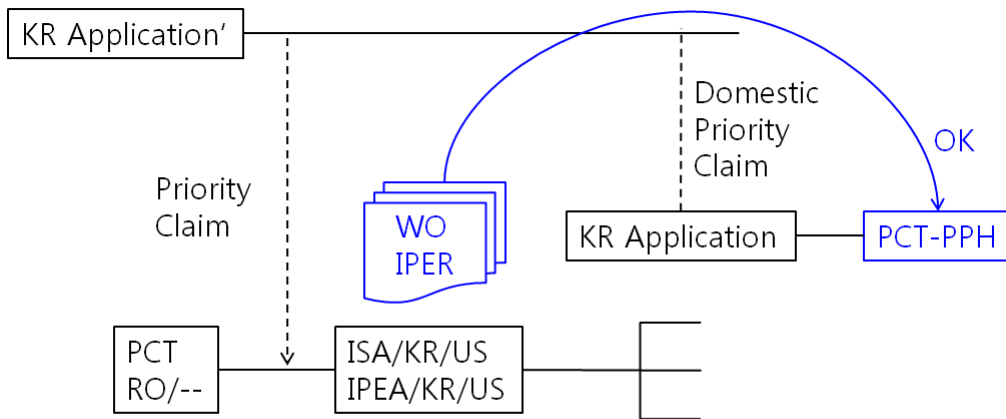

(E2) The application is an application claiming domestic priority to an application which satisfies the requirement (B).

ANNEX II

Examples for the claim correspondence

1. The claims in the following cases (case 1 to case 4) are considered to “sufficiently correspond” to each other.

Case	“Patentable” claim(s)		PPH claim(s)		Correspondence
	Claim	Wording	Claim	Wording	
Case 1	1	A	1	A	PPH claim 1 is the same as “Patentable” claim 1.
Case 2	1	A	1 2	A A+a	PPH claim 1 is the same as “Patentable” claim 1. PPH claim 2 is created by adding a technical feature disclosed in the specification to “Patentable” claim 1.
Case 3	1 2 3	A A+a A+b	1 2 3	A A+b A+a	PPH claim 1 is the same as “Patentable” claim 1. PPH claims 2, 3 are the same as “Patentable” claims 3, 2, respectively.
Case 4	1	A	1	A+a	PPH claim 1 has an additional technical feature ‘a’ disclosed in the specification.

2. The claims in the following cases (case 5 and case 6) are NOT considered to “sufficiently correspond” to each other.

Case	“Patentable” claim(s)		PPH claim(s)		Explanation
	Claim	Wording	Claim	Wording	
Case 5	1	A product	1	A’ method	PPH claim 1 claims to a method, whereas “Patentable” claim 1 claims to a product. (The technical feature of “Patentable” claim is the same as that of PPH claim, but categories of both claims are different)
Case 6	1	A+B	1	A+C	PPH claim 1 is different from “Patentable” claim 1 in a component of the claimed invention. (PPH claim is created by altering part of the technical features of “Patentable” claim.)