

# Procedures to file a request to the JPO for Patent Prosecution Highway Pilot Program between the JPO and the Rospatent

(14/07/2011)

## Request to the JPO

Applicants can request accelerated examination by a prescribed procedure including submission of relevant documents on an application which is filed with the JPO and satisfies the following requirements under the JPO-Rospatent Patent Prosecution Highway pilot program based on the Rospatent application.

When filing a request for the PPH pilot program, an applicant must submit a request form "The Explanation of Circumstances Concerning Accelerated Examination" based on the procedure prescribed in "the Guidelines of the Accelerated Examination and Appeal."<sup>1</sup> Under the PPH pilot program, an applicant is not required to fill in the section "2. the disclosure of prior arts and comparison between the claimed invention and prior art" in "The Explanation of Circumstances Concerning Accelerated Examination".

### 1. Requirements

- (a) Both the JPO application on which PPH is requested and the Rospatent application(s) forming the basis of the PPH request shall have the same earliest date (whether this be a priority date or a filing date).**

For example, the JPO application (including PCT national phase application) may be either:

(Case I) an application which validly claims priority under the Paris Convention from the Rospatent application(s) (examples are provided in ANNEX, Figure A, B, C and D), or

(Case II) an application which provides the basis of a valid priority claim under the Paris Convention for the Rospatent application(s) (including PCT national phase application(s)) (examples are provided in ANNEX, Figure E, F and G), or

(Case III) an application which shares a common priority document with the Rospatent application(s) (including PCT national phase application(s)) (examples are provided in ANNEX, Figure H, I, J, K, L and M), or

(Case IV) a PCT national phase application where both the JPO application and the Rospatent application(s) are derived from a common PCT international application having no priority claim (an example is provided in ANNEX, Figure N).

- (b) At least one corresponding patent application exists in the Rospatent which has one or more claims that have been determined to be patentable by the Rospatent.**

The claims are determined to be patentable by the Rospatent when the Decision on the Grant of a Patent (Решение о выдаче патента) is notified.

---

<sup>1</sup> [http://www.jpo.go.jp/torikumi/t\\_torikumi/souki/pdf/v3souki/guideline.pdf](http://www.jpo.go.jp/torikumi/t_torikumi/souki/pdf/v3souki/guideline.pdf)

It is noted that the application is NOT eligible for this program in case where the examination was conducted in the Eurasian Patent Office and the patent right was validated in Russia as a designated state.

- (c) All claims on file, as originally filed or as amended, for examination under the PPH must sufficiently correspond to one or more of those claims indicated as allowable in the Rospatent.**

Claims are considered to "sufficiently correspond" where, accounting for differences due to translations and claim format, the claims in the JPO are of the same or similar scope as the claims in the Rospatent, or the claims in the JPO are narrower in scope than the claims in the Rospatent.

In this regard, a claim that is narrower in scope occurs when a Rospatent claim is amended to be further limited by an additional feature that is supported in the specification (description and/or claims).

A claim in the JPO which introduces a new/different category of claims to those claims indicated as allowable in the Rospatent is not considered to sufficiently correspond. For example, where the Rospatent claims only contain claims to a process of manufacturing a product, then the claims in the JPO are not considered to sufficiently correspond if the JPO claims introduce product claims that are dependent on the corresponding process claims.

- (d) The JPO has not begun examination of the patent application** (an example is provided in ANNEX, Figure O).

## **2. Documents to be submitted**

Documents (a) to (d) below must be submitted by attaching them to "The Explanation of Circumstances Concerning Accelerated Examination". It is noted that even when it is not needed to submit the documents mentioned below, the name of the documents must be listed in "The Explanation of Circumstances Concerning Accelerated Examination". Please refer to the Example Form below for a more detailed guidance.

- (a) Copies of all office actions<sup>2</sup> from the Rospatent, which were sent in regard to the corresponding patent application filed at the Rospatent, and translations of these office actions<sup>3</sup>.**

Both Japanese and English are acceptable as a translation language.

---

<sup>2</sup> Office actions are documents, which relate to substantive patent examination, such as Decision on the Refusal of the Grant of a Patent (Решение об отказе в выдаче патента) and Decision on the Grant of a Patent (Решение о выдаче патента).

<sup>3</sup> Machine translations are admissible, but if it is impossible for the examiner to understand the outline of the translated office action(s) or the patent claim(s), due to insufficient translation, the JPO examiner can request the applicant to resubmit translations.

**(b) Copies of all claims determined to be patentable by the Rospatent, and translations of them<sup>3</sup>.**

Both Japanese and English are acceptable as a translation language.

**(c) Copies of references cited by the Rospatent examiner**

If the references are patent documents, the applicant is not required to submit them, because the JPO usually possesses them. If the JPO does not possess such a patent document, the applicant must submit the patent document at the JPO examiner's request. Non-patent literature must always be submitted. The translations of the references are unnecessary.

**(d) Claim correspondence table**

Applicants must submit a claim correspondence table which indicates how all claims in the JPO application sufficiently correspond to the claims determined to be patentable by the Rospatent.

When claims are just literal translation, the applicant can just write down that "they are the same" in the table. When claims are not just literal translation, it is necessary to explain the sufficient correspondence of each claim based on the criteria 1.(c).

When an applicant has already submitted the above mentioned documents 2.(a) to 2.(d) to the JPO through simultaneous or past procedures, the applicant may incorporate the documents by reference and is thus not required to attach the documents.

If the application does not fulfill the requirements 1. and 2. above, the request for accelerated examination will not be accepted. In that case, the JPO will notify the applicant (or the representative) hereof and inform of the reasons why the request for the accelerated examination is dismissed.

### **3. Example of “The Explanation of Circumstances Concerning Accelerated Examination” for filing request an accelerated examination under the PPH pilot program**

#### **(1) Circumstances**

Please indicate the relationship between the JPO application on which PPH is requested and the corresponding Rospatent application(s) from the aspect of the above Requirement 1.(a), and state that an accelerated examination is requested under the PPH program. The application number(s) of the corresponding Rospatent application(s) must be specified. If the application requested for the PPH or the corresponding Rospatent application(s) is a derived application (e.g., the Rospatent application that is indicated to be allowable/patentable is a divisional application of a Rospatent application which forms the basis of the priority claim of the JPO application), please indicate the application number of its basic application.

#### **(2) Documents to be submitted**

The applicant must list all required documents mentioned above in requirement 2.(a) to 2.(d) in an identifiable way, even when the applicant are allowed to omit the submission of certain documents according to these requirements 2.(a) to 2.(d).

#### **(3) Notice**

Forms of “The Explanation of Circumstances Concerning Accelerated Examination” are different between on-line procedure and paper procedure. Please refer to the examples of forms when filling in (“Form 1 for Accelerated Examination” for on-line procedures, and “Form 2 for Accelerated Examination” for paper procedures.).

## Example Form for the on-line PPH filing procedure

【書類名】	早期審査に関する事情説明書	} Bibliographical items
	The name of this paper	
【提出日】	平成00年00月00日	
	Date of filing	
【あて先】	特許庁長官殿	
	Destination	
【事件の表示】		
【出願番号】	特願 0000-000000	
	Application number	
【提出者】		
【識別番号】	000000000	
【住所又は居所】	〇〇県〇〇市〇丁目	
【氏名又は名称】	〇〇〇〇	
	The name and address of the submitter	
【代理人】		
【識別番号】	000000000	
【住所又は居所】	〇〇県〇〇市〇丁目	
【氏名又は名称】	〇〇 〇〇	
	The name and address of the attorney	
【早期審査に関する事情説明】		
	The explanation of circumstances concerning accelerated examination	
1. 事情		
	本出願とロシア特許庁への対応出願(特許出願番号0000000)は、共に、米国特許商標庁への一つの出願(出願番号00/000000)に対してパリ条約に基づく優先権を有効に主張する出願であり、特許審査ハイウェイ試行プログラムに基づく早期審査の申請を行うものである。	
1. Circumstances		
	Both this application and the corresponding Rospatent application (the application number is 0000000) validly claim priority under the Paris Convention to a USPTO application (the application number is 00/000000), and the accelerated examination is requested under the PPH program.	
	以下において、「引用非特許文献1」とは、「村岡洋一著、「コンピュータサイエンス大学講座(第11巻)コンピュータ・アーキテクチャ」、第2版、株式会社近代科学者、1985年11月、p.123-127」である。	
	In what follows, “non-patent literature1” is “Yoichi Muraoka, Lecture of Computer Science (vol.11) computer architecture, 2 <sup>nd</sup> edition, Scientist com, Nov. 1985, p.123-127.”	

If the name of the document is long (over 50 letters), it is impossible to write it down directly to the column “【物件名】”. In this case, please write down the full name of the document in the column “【早期審査に関する事情説明】” and name it properly. Then write the name in the column “【物件名】”.

【提出物件の目録】

List up the documents to be submitted

The list of submitted documents

- 【物件名】 ロシア出願と本出願の請求項の対応関係を示す書面 1
- 【物件名】 \*\*年\*\*月\*\*日付の対応ロシア出願に対する拒絶理由通知の写し 1
- 【物件名】 \*\*年\*\*月\*\*日付の対応ロシア出願に対する特許査定 of 写し 1
- 【物件名】 対応ロシア出願の特許公報であるロシア特許第000000号公報 1
- 【物件名】 対応ロシア出願に対して引用された米国特許第000000号明細書 1
- 【物件名】 対応ロシア出願に対して引用された特開0000-000000号公報 1
- 【物件名】 引用非特許文献1 1

(The name of the document) The table explaining how the claims in the JPO application sufficiently correspond to the claims determined to be patentable by the Rospatent 1

(The name of the document) Copy of the Notification of Reasons for Refusal from the Rospatent on (date) 1

(The name of the document) Copy of the Decision to Grant a Patent from the Rospatent on (date) 1

(The name of the document) The publication of the granted patent of the corresponding Rospatent application: Russian Patent number 0000000 1

(The name of the document) Cited reference of the corresponding Rospatent application: US 0000000 A 1

(The name of the document) Cited reference of the corresponding Rospatent application: JP 0000-000000 A 1

(The name of the document) Cited non-patent literature1 1

Use the same name as in “【物件名】” under “【提出物件の目録】.”

【添付物件】

The list of attached documents

【物件名】 ロシア出願と本出願の請求項の対応関係を示す書面

The table explaining how the claims in the JPO application sufficiently correspond to the claims determined to be patentable by the Rospatent

Attach the document here as image file or text.

【内容】

本出願の 請求項 The claim filed to the JPO	ロシアで特許可能 とされた請求項 The claim determined to be patentable in the Rospatent	対応関係に関するコメント Comments about the correspondence
1	1	両クレームは同一である。 Both claims are the same.
2	2	"
3	1	両クレームは、記載形式を除き同一である。 Both claims are the same except the claim format.
4	2	"
5	1	請求項5は、ロシアの請求項1にAという発明特定事項を 付加したものである。 Claim 5 in the JPO application adds composition A to claim 1 of the Rospatent application

【物件名】 引用非特許文献1

Cited non-patent literature1

Use the same name as in “【物件名】”  
under “【提出物件の目録】.”

【内容】

Attach the copy of the document.

A

(Case I)  
- Paris route -

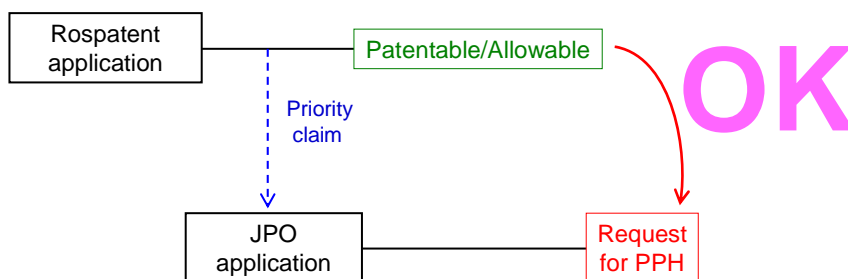

B

(Case I)  
- PCT route -

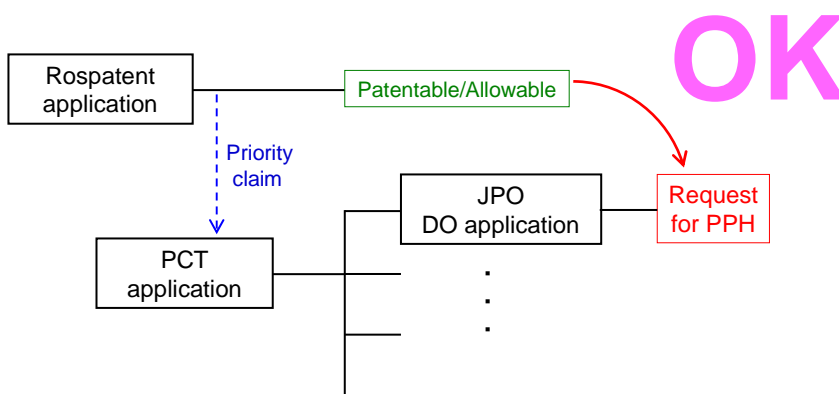

C

(Case I)  
- Paris route & Complex priority -

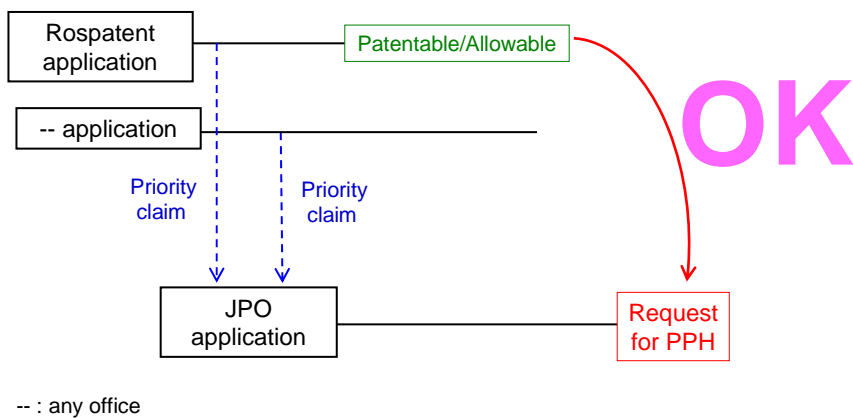

D

(Case I)  
- Paris route & divisional application -

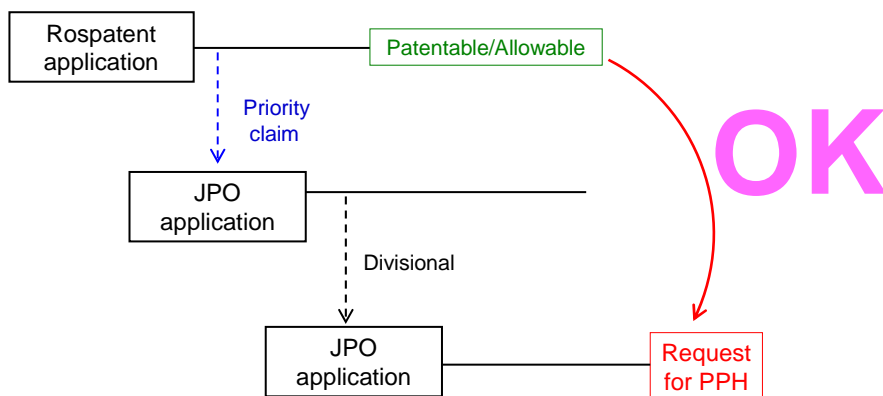

E

(Case II)  
- Paris route -

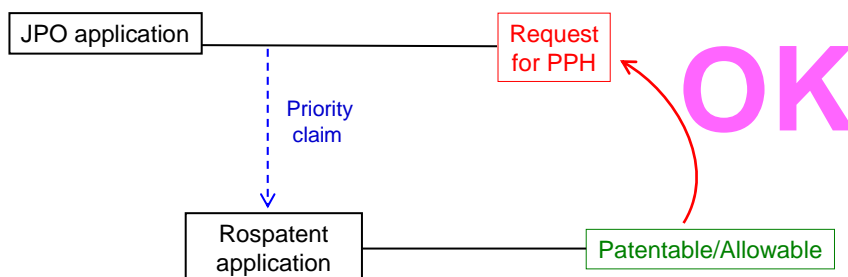

F

(Case II)  
- PCT route -

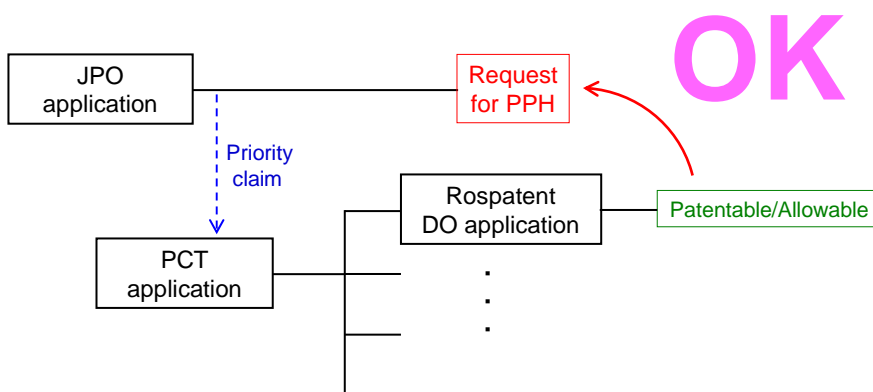

G

(Case II)

- Paris route & Complex priority -

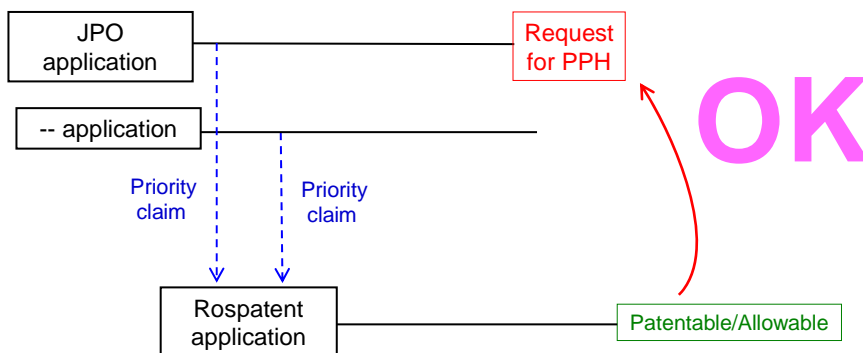

-- : any office

H

(Case III)

- Paris route, Divisional application-

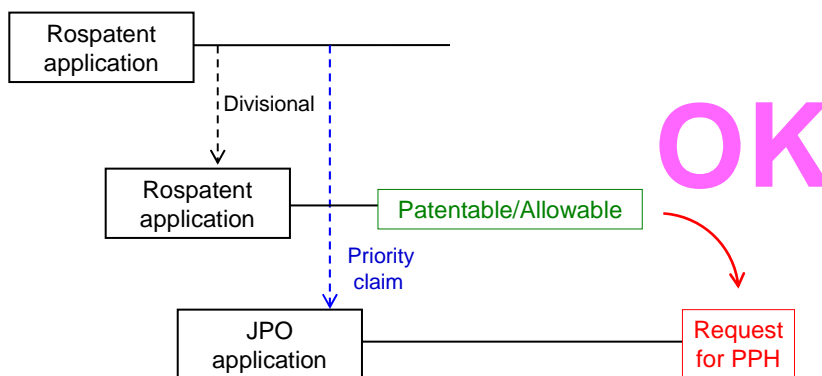

I

*(Case III)*

- Paris route, Internal priority -

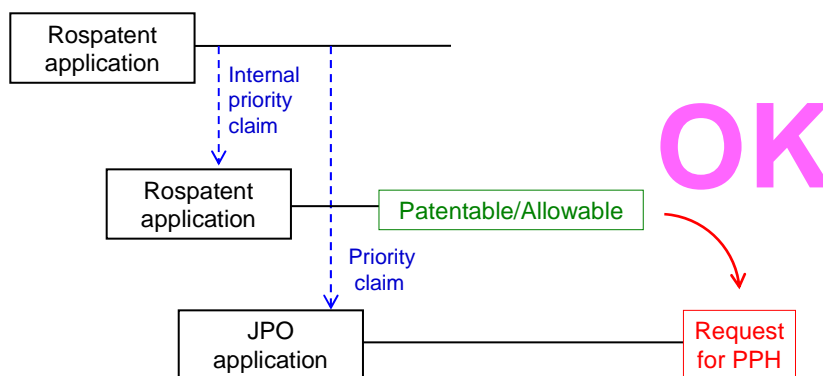

J

*(Case III)*

- Paris route, but the first application is from the third country -

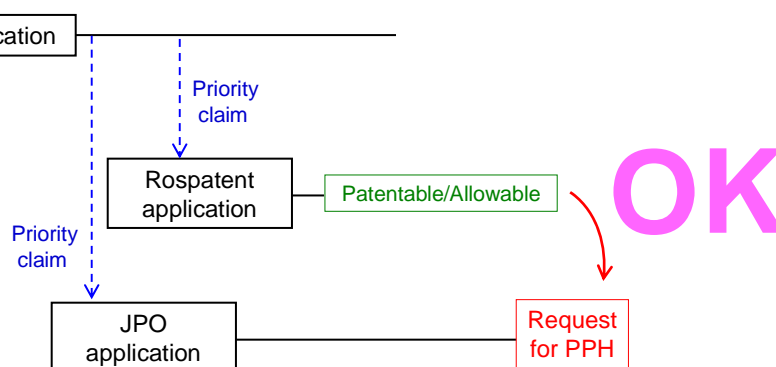

-- : the office other than the JPO and the Rospatent

K

(Case III)

- PCT route, but the first application is from the third country -

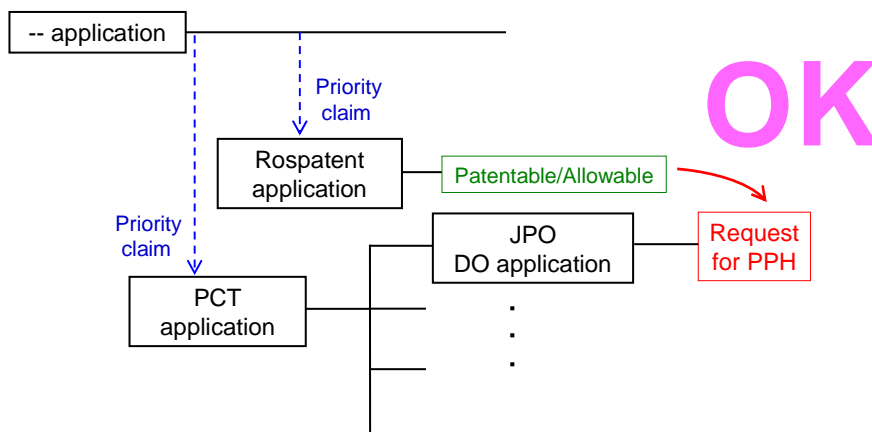

-- : the office other than the JPO and the Rospatent

L

(Case III)

- PCT route -

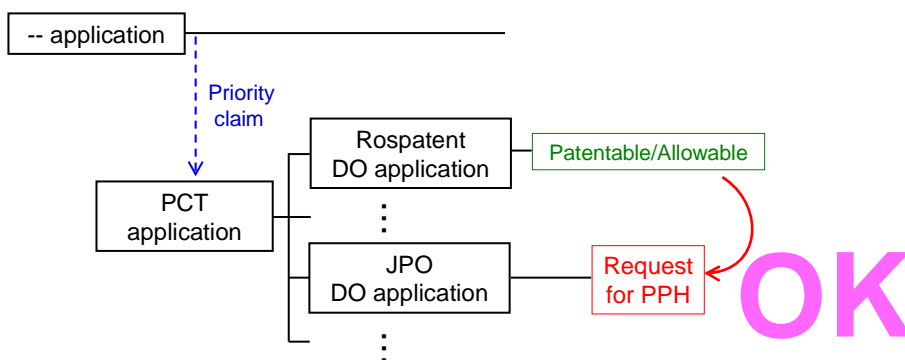

-- : any office

M

(Case III)  
- Direct PCT & PCT route -

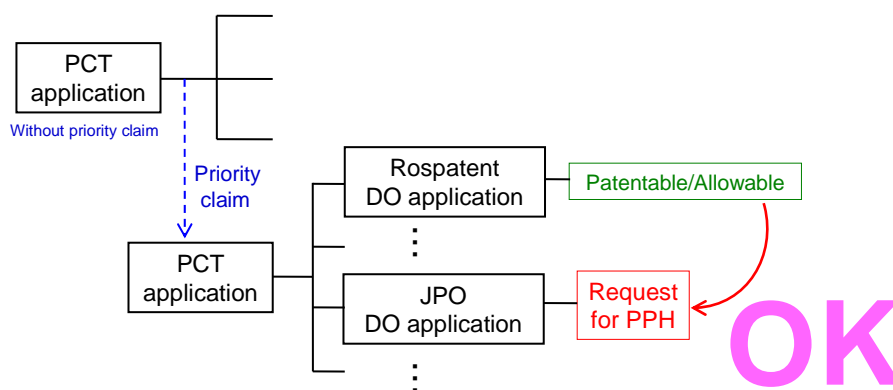

N

(Case IV)  
- Direct PCT route -

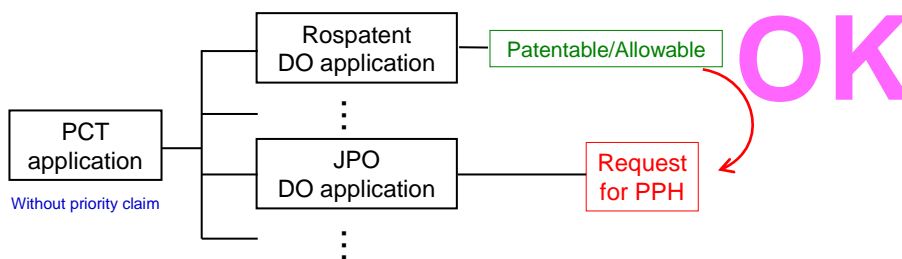

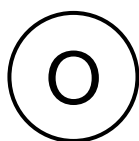

### *A case not meeting requirement (d)*

- Examination has begun before a request for PPH -

