

Procedures to file a request to the
Icelandic Patent Office (IPO)
for the
PCT- Patent Prosecution Highway
Pilot Program between the
Japan Patent Office (JPO)
and the
Icelandic Patent Office (IPO)

Request to the IPO

An applicant should file a request for accelerated examination under the PCT-Patent Prosecution Highway (PPH) to the IPO by submitting a letter requesting accelerated examination under the PCT-PPH accompanied by the relevant supporting documents, including completed PPH request form. The requirements for an application to the IPO for accelerated examination under the PCT-PPH are given in section 1 and relevant supporting documentation is discussed in section 2.

PPH using the PCT international work products

1 Requirements

The application which is filed with the IPO and for which the applicant files a request for an accelerated examination under the PCT-PPH must satisfy the following requirements:

1.1 The relationship between the application and the corresponding international application

The relationship between the application and the corresponding international application satisfies one of the following requirements:

(A) The application is a national phase application of the corresponding international application (examples are provided in Annex 2: figures A, A', and A'').

(B) The application is a national application from which the corresponding international application claims priority (example is provided in Annex 2: figure B).

(C) The application is a national phase application of an international application claiming priority from the corresponding international application (example is provided in Annex 2: figure C).

(D) The application is a national application claiming foreign/domestic priority from the corresponding international application (example is provided in Annex 2: figure D).

(E) The application is the derivative application (divisional application, application claiming internal priority, etc.) of the application which satisfies one of the above requirements (A) – (D) (examples are provided in Annex 2: figures E1 and E2).

1.2 The application has one or more claims that are determined to be allowable in the latest work product of the corresponding PCT application

The latest work product (WO/ISA, WO/IPEA or IPER) in the international phase of a PCT application corresponding to the application, must indicate that at least one claim is allowable (from the aspect of novelty, inventive step and industrial applicability). The applicant cannot file a request under PCT-PPH on the basis of an International Search Report (ISR) only.

If any observation is made in Box VIII of the work product which the request for PCT-PPH is based upon, the applicant must explain why the claim(s) is/are not subject to the observation and whether or not an amendment is submitted to correct the observation. The application will not be eligible for participating in the PCT-PPH pilot program if the applicant fails to explain why the claim(s) is/are not subject to the observation. However, in this regard, it does not affect the decision on the eligibility of the application, whether the explanation is adequate and/or whether the amendment submitted overcomes the observation.

Note that the ISA / IPEA which produced the WO/ISA, WO/IPEA and the IPER must be the JPO, however the application from which priority is claimed could be from any office, see Annex 2, example A' (application ZZ can be any national application).

1.3 Claim correspondence

All claims on file, as originally filed or as amended, for examination under the PCT-PPH must sufficiently correspond to one or more of those claims indicated as allowable in the JPO as

ISA/IPEA.

Claims are considered to "sufficiently correspond" where, accounting for differences due to translations and claim format, the claims in the IPO are of the same or similar scope as the claims in the JPO, or the claims in the IPO are narrower in scope than the claims in the JPO.

In this regard, a claim that is narrower in scope occurs when a claim indicated as allowable in the JPO is amended to be further limited by an additional feature that is supported in the specification (description and/or claims).

A claim in the IPO which introduces a new/different category of claims to those claims indicated as allowable in the JPO is not considered to sufficiently correspond. For example, the claims indicated as allowable in the JPO only contain claims to a process of manufacturing a product, then the claims in the IPO are not considered to sufficiently correspond if the claims in the IPO introduce product claims that are dependent on the corresponding process claims.

1.4 The Office of the application has not begun examination of the application at the time of request for the PPH

The request for the PPH shall be permitted only before the applicant receives the notification whose heading would be "Rannsókn einkaleyfisumsóknar" (Examination of patent application).

2 Documents to be submitted when filing a request for accelerated examination under the PCT-PPH

The applicant must submit the following documents 2.1-2.4 attached to the request form (see Annex 3) when filing a request under PCT-PPH. All documents under this paragraph with exception for the cited documents have to be drawn up in or translated to Danish or English.

2.1 A copy of the latest international work product of the corresponding international application

In case the application satisfies the relationship 1.1 (A), the applicant does **not** need to submit a copy of the International Preliminary Report on Patentability (IPRP) because a copy of these documents is already available in the file-wrapper of the application. In addition, if the copy of the latest international work product is available via PATENTSCOPE^{®*}, an applicant does not need to submit these documents, unless otherwise requested by the patent Office (WO/ISA and IPER are usually available as

“IPRP Chapter I” and “IPRP Chapter II” respectively after 30 months from the priority date.)

2.2 A copy of a set of claims which the latest international work product of the corresponding international application indicated as allowable

A copy of a set of claims which the latest international work product of the corresponding international application indicated as allowable.

If the copy of the set of claims which are indicated as allowable is available via PATENTSCOPE[®] (or the international Patent Gazette has been published), an applicant does not need to submit this document, unless otherwise requested by the IPO. Where translations of the allowable claims are necessary, they must be submitted by the applicant since PATENTSCOPE[®] does not provide them.

2.3 Copies of references cited in the latest international work product of the corresponding international application

If the references are patent documents, the applicant does not have to submit them because the IPO usually has access to them. When the IPO does not have access to the patent document, the applicant has to submit the patent document at the Office’s request. Non-patent literature must always be submitted.

Submission of translation of the references is not required. However, applicants will be free to file translations as part of the supporting documentation when initially requesting accelerated examination under the PCT-PPH to allow prompt consideration of the citations if the applicants so desire.

2.4 Claim correspondence table

The applicant must submit a claim correspondence table to explain the correspondence of claims determined to be allowable in the latest work product of the corresponding international application and all claims in the application (See Annex 1).

2.5 Request form

An applicant should submit a request form (See Annex 3) for the accelerated examination under

the PCT-PPH along with the documents referred to in paragraphs 2.1-2.4.

When the applicant has already submitted the documents mentioned above in paragraphs 2.1 – 2.4 to the IPO in an examination procedure of the patent family application, through simultaneous or past procedures, the applicant may incorporate the documents by reference and is thus not required to attach the documents.

Procedure for the accelerated examination under the PCT-PPH

The applicant files a letter requesting accelerated examination under the PPH Pilot Program to the IPO, including the relevant supporting documents and a completed request form (see Annex 3).

If the request does not meet all the requirements set forth above, the applicant will be notified and the defects in the request will be identified. The applicant will be given opportunity to correct the request. If the defect(s) are not corrected, the applicant will be notified, and the application will await action in its regular turn. If an examination of the application has begun after the applicant has been notified of the defects in the request, any renewed request will be dismissed.

If the request for participation in the PPH pilot program meets all the requirements and examination has not begun, the IPO will decide whether a patent will be issued based on the search and examination carried out by the JPO or sent to the Danish Patent and Trademark Office (DKPTO) for examination, in accordance with a partnership agreement. If the application is sent to the DKPTO their patent examiners will conduct the accelerated examinations

ANNEX 1

Examples for the claim correspondence table

The claims in the following cases are considered to “sufficiently correspond”.



EX.1

<i>Claims in the international phase</i>	<i>IPO claims</i>	<i>Comment</i>
1	1	<i>The IPO claim has the additional component on the claim that is determined to be patentable by JPO..</i>

Allowable claim, corresponding PCT-appl.	Claim, national appl.
<p>A system for presenting a container storing at least one article to a processing tool, comprising:</p> <p>(a) a load port, including: a frame having an opening; a support structure being adapted to receive a container, and a drive mechanism for moving said support structure substantially vertically between a first height and a second height; and</p> <p>(b) a conveyor for movably supporting the container substantially along a container transport plane; wherein a container traveling on said conveyer moves unobstructed over said support structure when said support structure is located in said second height, wherein the container traveling unobstructed does not contact said support structure while traveling over said support structure located at said second height, wherein said support structure, when located at said second height, is located below said transport plane.</p> <p><u>*This additional part is NOT included in the allowable claim but it is included in the description of the national claim</u></p>	<p>A system for presenting a container storing at least one article to a processing tool, comprising:</p> <p>(a) a load port, including: a frame having an opening; a support structure being adapted to receive a container, and a drive mechanism for moving said support structure substantially vertically between a first height and a second height; and</p> <p>(b) a conveyor for movably supporting the container substantially along a container transport plane; wherein a container traveling on said conveyer moves unobstructed over said support structure when said support structure is located in said second height, wherein the container traveling unobstructed does not contact said support structure while traveling over said support structure located at said second height, wherein said support structure, when located at said second height, is located below said transport plane, <u>wherein said support structure, when located at said first height, is located above said transport plane*</u>.</p>

EX.2

<i>Claims in the international phase</i>	<i>IPO claims</i>	<i>Comment</i>
<i>1</i>	<i>1</i>	<i>Same</i>
<i>none</i>	<i>2</i>	<i>The IPO claim2 is dependent on the IPO claim1, which has been determined to be patentable by JPO.</i>

Allowable claim, corresponding PCT-appl.	Claim, national appl.
1. A nitride-based semiconductor device comprising: a first semiconductor layer, consisting of either an n-type nitride-based semiconductor layer having a wurtzite structure or an n-type nitride-based semiconductor substrate having a wurtzite structure; and an n-side electrode formed on a back surface of said first semiconductor layer, wherein a dislocation density is not more than $1 \times 10^9 \text{ cm}^{-2}$ in the vicinity of the interface between said first semiconductor layer and said n-side electrode, and contact resistance between said n-side electrode and said first semiconductor layer is not more than $0.05 \text{ } \Omega \text{ cm}^2$	1. (Same) 
2. (None)	2. <i>The nitride-based semiconductor device according to claim 1, wherein said first semiconductor layer includes an n-type dopant*</i> . 

*This additional part is NOT included in the allowable claim but it is included in the description of the national application

ANNEX 2

Examples of the applications eligible for PCT-PPH

(A) The application is a national phase application of the corresponding international application.

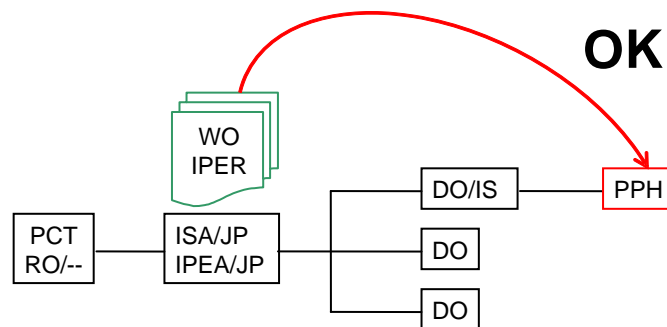

(A') The application is a national phase application of the corresponding international application. (The corresponding international application claims priority from a national application.)

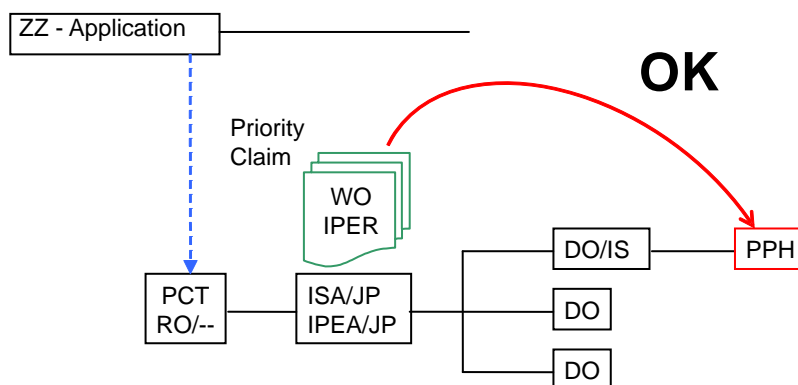

ZZ = any office

**(A”) The application is a national phase application of the corresponding international application.
 (The corresponding international application claims priority from an international application.)**

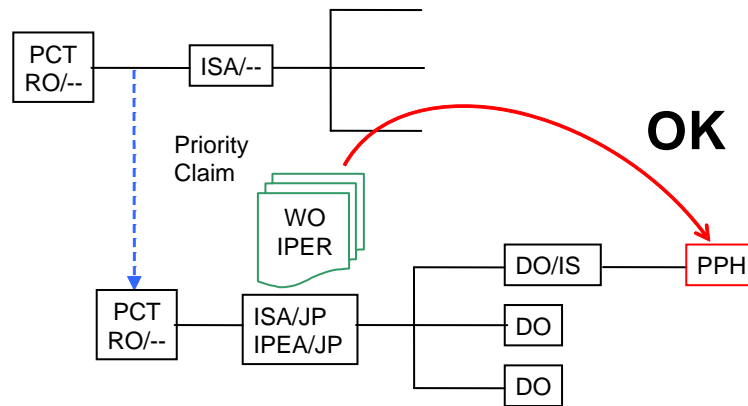

(B) The application is a national application from which the corresponding international application claims priority.

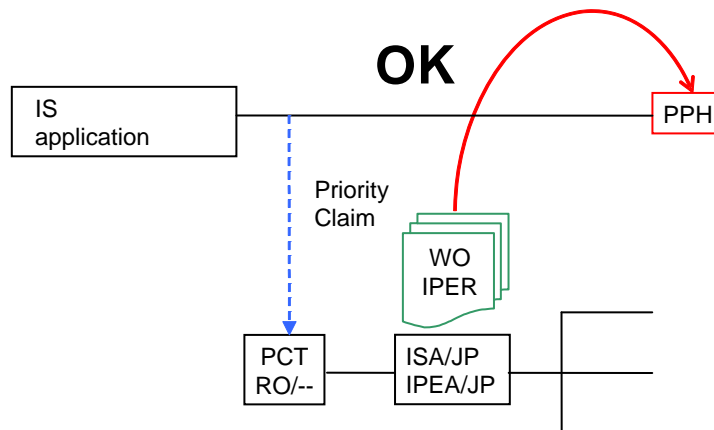

(C) The application is a national phase application of an international application claiming priority from the corresponding international application.

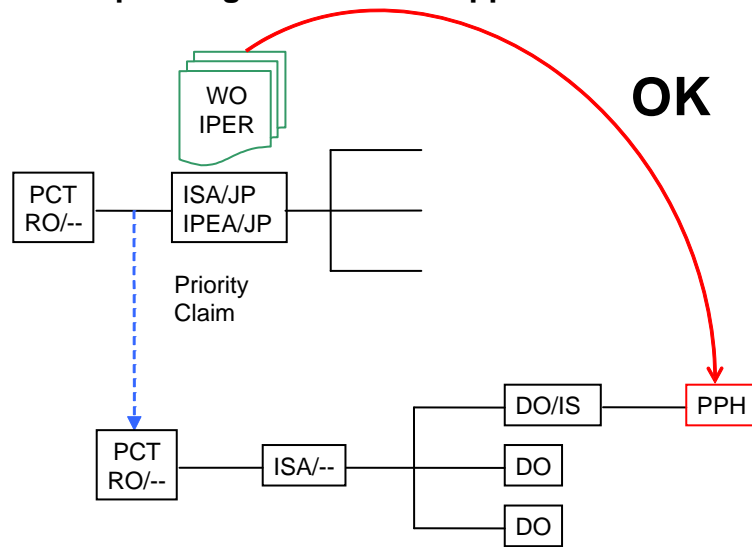

(D) The application is a national application claiming foreign/domestic priority from the corresponding international application.

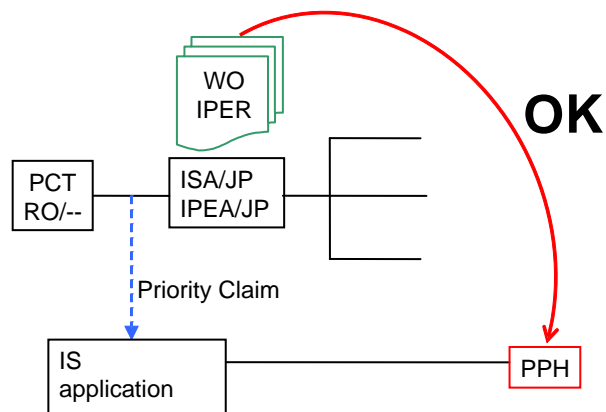

(E1) The application is a divisional application of an application which satisfies the requirement (A).

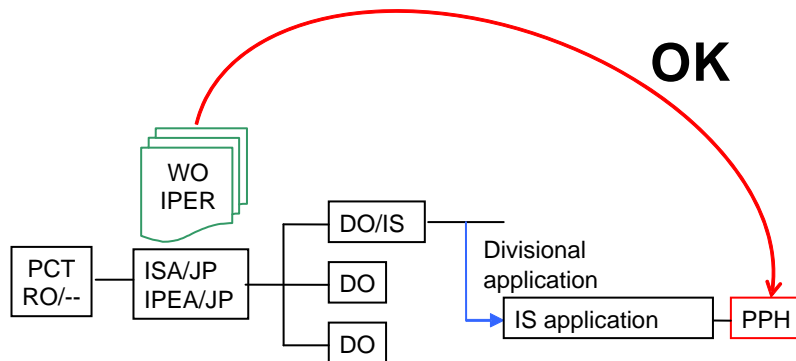

(E2) The application is an application claiming domestic priority from an application which satisfies the requirement (B).

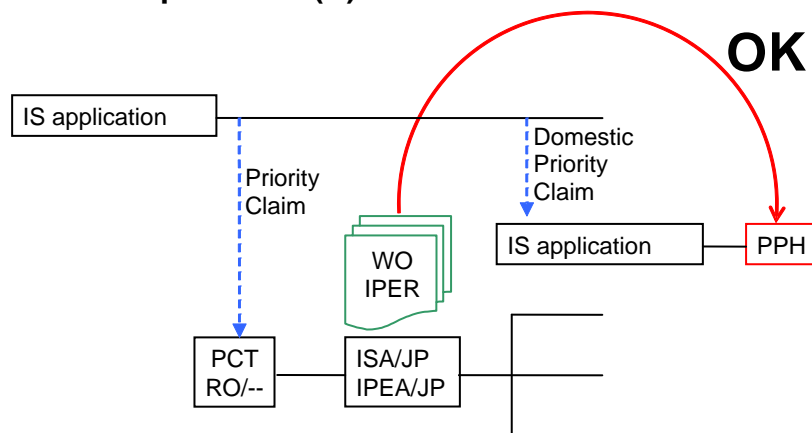

ANNEX 3

PCT-PPH REQUEST

Request for Accelerated Examination at the Icelandic Patent Office (IPO) using the PCT international work products under the Patent Prosecution Highway Pilot Program between the IPO and the Japan Patent Office (PCT-PPH pilot program)

IS application number:

Corresponding PCT application number:

For the purposes of participation in the PCT-PPH, the following documents should be attached/are required:

1. Either:
 - 1a) A copy of WO-ISA, WO-IPEA or IPER and translation thereof in English or Danish
or
 - 1b) Request to obtain documents in 1a) via PATENTSCOPE®

2. Either:
 - 2a) A copy of all claims determined to be patentable/allowable by the ISA or IPEA
or
 - 2b) Request to obtain documents in 2a) via the PATENTSCOPE®

3. Translation of the documents in 2. in English or Danish.

4. Copies of all documents cited in the WO-ISA, WO-IPEA or IPER (except for patent documents)

5. Claim correspondence table

