

Procedures to file a request to the NIPO for Patent Prosecution Highway Pilot Program between the JPO (Japan Patent Office) and the NIPO (Norwegian Industrial Property Office)

Part I

PPH using the national work products from the JPO

Applicants can request accelerated examination by the procedure prescribed in this document including submission of relevant documents on an application which is filed with the NIPO and satisfies the following requirements under the JPO-NIPO Patent Prosecution Highway pilot program based on the JPO application.

1. Requirements

(a) The NIPO application (including PCT national phase application) is

- (i) an application which validly claims priority under the Paris Convention to the JPO application(s) (examples are provided in ANNEX 2, figure A, B, C, F, G and H), or***
- (ii) a PCT national phase application without priority claim (an example is provided in Annex 2, figure I), or***
- (iii) an application which validly claims priority under the Paris Convention to the PCT application(s) without priority claim (examples are provided in ANNEX 2, figure J, K and L).***

The NIPO application, which validly claims priority to multiple JPO or direct PCT applications, or which is the divisional application validly based on the originally filed application that is included in (i) to (iii) above, is also eligible.

(b) At least one corresponding application exists in the JPO and has one or more claims that are determined to be patentable/allowable by the JPO.

The corresponding application can be an application which provides the basis of the priority claim under the Paris Convention for the NIPO application, an application which derived from the JPO application which forms the basis of the priority claim (e.g. a divisional application of the JPO application), or an JPO national phase application of a PCT application.

Claims are “determined to be allowable/patentable” when the JPO examiner clearly identifies the claims to be allowable/patentable in the latest office action, even if the

application is not granted for patent yet. The office action may be either:

- (i) Decision to Grant a Patent
- (ii) Notification of Reasons of Refusal
- (iii) Decision of Refusal
- (iv) Appeal Decision

(c) All claims on file, as originally filed or as amended for examination under the PPH must sufficiently correspond to one or more of those claims indicated as allowable in the JPO.

Claims are considered to "sufficiently correspond" where, accounting for differences due to translations and claim format, the claims in the NIPO are of the same or similar scope as the claims in the JPO, or the claims in the NIPO are narrower in scope than the claims in the JPO.

In this regard, a claim that is narrower in scope occurs when a JPO claim is amended to be further limited by an additional feature that is supported in the specification (description and/or claims).

A claim in the NIPO which introduces a new/different category of claims to those claims indicated as allowable in the JPO is not considered to sufficiently correspond. For example, where the JPO claims only contain claims to a process of manufacturing a product, then the claims in the NIPO are not considered to sufficiently correspond if the NIPO claims introduce product claims that are dependent on the corresponding process claims.

Any claims amended or added after the grant of the request for participation in the PPH pilot program need not to sufficiently correspond to the claims indicated as allowable in the JPO application.

(d) The NIPO has not begun examination of the application at the time of request for the PPH (an example is provided in ANNEX M).

2. Documents to be submitted

Documents (a) to (d) below must be submitted by attaching to the request form (see Annex 3).

All documents under this paragraph with exception for the cited documents have to be drawn up in or translated to Norwegian or English.

(a) Copies of all office actions (which are relevant to substantial examination for

patentability in the JPO), which were sent for the corresponding application by the JPO, and translations of them¹.

Either Norwegian or English is acceptable as translation language.

The applicant does not have to submit a copy of JPO office actions and translations of them when the office actions are provided via AIPN (JPO's dossier access system). If the office actions cannot be obtained by the NIPO examiner via the AIPN, the applicant may be notified and requested to provide the necessary documents.

(b) Copies of all claims determined to be patentable/allowable by the JPO, and translations of them¹.

Either Norwegian or English is acceptable as translation language.

The applicant does not have to submit a copy of claims indicated to be allowable/patentable in the JPO, and translations thereof when the claims are provided via AIPN (JPO's dossier access system). If the claims cannot be obtained by the NIPO examiner via the AIPN, the applicant may be notified and requested to provide the necessary documents.

(c) Copies of references cited by the JPO examiner

If the references are patent documents, the applicant doesn't have to submit them because the NIPO usually possesses them. When the NIPO does not possess the patent document, the applicant has to submit the patent document at the examiner's request. Non-patent literature must always be submitted.

The translations of the references are unnecessary.

(d) Claim correspondence table

The applicant requesting PPH must submit a claim correspondence table, which indicates how all claims in the NIPO application sufficiently correspond to the patentable/allowable claims in the JPO application.

When claims are just literal translation, the applicant can just write down that "they are the same" in the table. When claims are not just literal translation, it is necessary to explain the sufficient correspondence of each claim based on the criteria 1. (c).

¹ Machine translations will be admissible, but if it is impossible for the examiner to understand the outline of the translated office action or claims due to insufficient translation, the examiner can request the applicant to resubmit translations.

When the applicant has already submitted above documents (a) to (d) to the NIPO through simultaneous or past procedures, the applicant may incorporate the documents by reference and does not have to attach them.

3. Procedure for accelerated examination under the PPH pilot program

The applicant files a letter requesting accelerated examination under the PPH pilot program to the NIPO, including the relevant supporting documents and a completed request form (see Annex 3).

The NIPO decides whether the application can be entitled the status of accelerated examination under the PPH when NIPO receives a request with the documents stated above. When NIPO decides that a request is acceptable, the application is assigned a special status for accelerated examination.

If the request does not meet all the requirements set forth above, the applicant will be notified and the defects in the request will be identified. The applicant will be given opportunity to correct the request. If the defect(s) are not corrected, the applicant will be notified, and the application will await action in its regular turn.

Part II

PPH using the PCT international work products from the JPO

An applicant can request accelerated examination by a prescribed procedure including submission of relevant documents on an application which is filed with the NIPO and satisfies the following requirements under the NIPO-JPO Patent Prosecution Highway Pilot Program based on PCT international work products (PCT-PPH Pilot Program).

1. Requirements

1.1 The relationship between the application and the corresponding international application satisfies one of the following requirements:

- (A) The application is a national phase application of the corresponding international application (examples are provided in Annex 5: figures A, A' and A'').
- (B) The application is a national application as a basis of the priority claim of the corresponding international application (example is provided in Annex 5: figure B).
- (C) The application is a national phase application of an international application claiming priority from the corresponding international application (example is provided in Annex 5: figure C).
- (D) The application is a national application claiming foreign/domestic priority from the corresponding international application (example is provided in Annex 5: figure D).
- (E) The application is the derivative application (divisional application, application claiming internal priority, etc.) of the application which satisfies one of the above requirements (A) – (D) (examples are provided in Annex 5: figures E1 and E2).

1.2 The application has one or more claims that are determined to be allowable in the latest work product of the corresponding PCT application.

The latest work product (WO/ISA, WO/IPEA or IPER) in the international phase of a PCT application corresponding to the application, must indicate that at least one claim is allowable (from the aspect of novelty, inventive step and industrial applicability). The applicant cannot file a request under PCT-PPH on the basis of an International Search Report (ISR) only.

If any observation is made in Box VIII of the work product which the request for PCT-PPH is based upon, the applicant must explain why the claim(s) is/are not subject to the observation and whether or not an amendment is submitted to correct the observation. The application will not be eligible for participating in the PCT-PPH pilot program if the applicant fails to explain why the claim(s) is/are not subject to the

observation. However, in this regard, it does not affect the decision on the eligibility of the application, whether the explanation is adequate and/or whether the amendment submitted overcomes the observation.

Note that the ISA / IPEA which produced the WO/ISA, WO/IPEA and the IPER must be the JPO, however the application from which priority is claimed could be from any office, see Annex 5, example A' (application ZZ can be any national application).

1.3 Claim correspondence

All claims on file, as originally filed or as amended, for examination under the PCT-PPH must sufficiently correspond to one or more of those claims indicated as allowable in the JPO as ISA/IPEA.

Claims are considered to "sufficiently correspond" where, accounting for differences due to translations and claim format, the claims in the NIPO are of the same or similar scope as the claims in the JPO, or the claims in the NIPO are narrower in scope than the claims in the JPO.

In this regard, a claim that is narrower in scope occurs when a claim indicated as allowable in the JPO is amended to be further limited by an additional feature that is supported in the specification (description and/or claims).

A claim in the NIPO which introduces a new/different category of claims to those claims indicated as allowable in the JPO is not considered to sufficiently correspond. For example, the claims indicated as allowable in the JPO only contain claims to a process of manufacturing a product, then the claims in the NIPO are not considered to sufficiently correspond if the claims in the NIPO introduce product claims that are dependent on the corresponding process claims.

1.4 The NIPO has not begun examination of the application at the time of request for the PCT-PPH.

2. Documents to be submitted

The applicant must submit the following documents 2.1-2.4 attached to the request form (see Annex 6) when filing a request under PCT-PPH. All documents under this paragraph with exception for the cited documents have to be drawn up in or translated to Norwegian or English.

2.1 A copy of the latest international work product of the corresponding

international application.

In case the application satisfies the relationship 1.1 (A), the applicant does **not** need to submit a copy of the International Preliminary Report on Patentability (IPRP) if a copy of these documents is already available in the file-wrapper of the application. In addition, if the copy of the latest international work product is available via PATENTSCOPE^{®*}, an applicant does not need to submit these documents, unless otherwise requested by the patent Office (WO/ISA and IPER are usually available as “IPRP Chapter I” and “IPRP Chapter II” respectively after 30 months from the priority date.)

2.2 A copy of a set of claims which the latest international work product of the corresponding international application indicated as allowable.

If the copy of the set of claims which are indicated as allowable is available via PATENTSCOPE[®] (or the international Patent Gazette has been published), an applicant does not need to submit this document, unless otherwise requested by the patent Office. Where translations of the allowable claims are necessary, they must be submitted by the applicant since PATENTSCOPE[®] does not provide them.

2.3 Copies of references cited in the latest international work product of the corresponding international application.

If the references are patent documents, the applicant does not have to submit them because the Office of the application usually has access to them. When the Office of the application does not have access to the patent document, the applicant has to submit the patent document at the examiner’s request. Non-patent literature must always be submitted.

Submission of translation of the references is not required. However, applicants will be free to file translations as part of the supporting documentation when initially requesting accelerated examination under the PCT-PPH to allow prompt consideration of the citations if the applicants so desire.

2.4 Claim correspondence table

The applicant must submit a claim correspondence table to explain the correspondence of claims determined to be allowable in the latest work product of the corresponding international application and all claims in the application (See Annex 4).

2.5 Request form

An applicant should submit a request form (See Annex 6) for the accelerated examination under the PCT-PPH along with the documents referred to in paragraphs 2.1-2.4. When the applicant has already submitted the documents mentioned above in paragraphs 2.1 - 2.4 to the patent Office in an examination procedure of the patent family application, through simultaneous or past procedures, the applicant may incorporate the documents by reference and is thus not required to attach the documents.

3. Procedure for accelerated examination under the PCT-PPH pilot program

The applicant files a letter requesting accelerated examination under the PCT-PPH Pilot Program to the NIPO, including the relevant supporting documents and a completed request form (see Annex 6).

The NIPO decides whether the application can be entitled the status of accelerated examination under the PCT-PPH when NIPO receives a request with the documents stated above. When NIPO decides that a request is acceptable, the application is assigned a special status for accelerated examination.

If the request does not meet all the requirements set forth above, the applicant will be notified and the defects in the request will be identified. The applicant will be given opportunity to correct the request. If the defect(s) are not corrected, the applicant will be notified, and the application will await action in its regular turn.

ANNEX 1

Examples for the claim correspondence table

The claims in the following cases are considered to “sufficiently correspond”.

EX.1

<i>JPO claims</i>	<i>NIPO claims</i>	<i>Comments</i>
1	1	<i>The NIPO claim has the additional component on the claim that is determined to be patentable by JPO.</i>

Allowable claim, corresponding JPO appl.	Claim, NIPO appl.
<p>A system for presenting a container storing at least one article to a processing tool, comprising:</p> <p>(a) a load port, including:</p> <p>a frame having an opening;</p> <p>a support structure being adapted to receive a container, and</p> <p>a drive mechanism for moving said support structure substantially vertically between a first height and a second height; and</p> <p>(b) a conveyor for movably supporting the container substantially along a container transport plane;</p> <p>wherein a container traveling on said conveyor moves unobstructed over said support structure when said support structure is located in said second height,</p> <p>wherein the container traveling unobstructed does not contact said support structure while traveling over said support structure located at said second height,</p> <p>wherein said support structure, when located at said second height, is located below said transport plane.</p> <p><u>*This additional part is NOT included in the allowable claim but it is included in the description of the national claim</u></p>	<p>A system for presenting a container storing at least one article to a processing tool, comprising:</p> <p>(a) a load port, including:</p> <p>a frame having an opening;</p> <p>a support structure being adapted to receive a container, and</p> <p>a drive mechanism for moving said support structure substantially vertically between a first height and a second height; and</p> <p>(b) a conveyor for movably supporting the container substantially along a container transport plane;</p> <p>wherein a container traveling on said conveyor moves unobstructed over said support structure when said support structure is located in said second height,</p> <p>wherein the container traveling unobstructed does not contact said support structure while traveling over said support structure located at said second height,</p> <p>wherein said support structure, when located at said second height, is located below said transport plane,</p> <p><u>wherein said support structure, when located at said first height, is located above said transport plane*</u></p>

EX.2

<i>JPO claims</i>	<i>NIPO claims</i>	<i>Comments</i>
<i>1</i>	<i>1</i>	<i>Same</i>
<i>none</i>	<i>2</i>	<i>The NIPO claim2 is dependent on the NIPO claim1, which has been determined to be patentable by JPO.</i>

Allowable claim, corresponding JPO appl.	Claim, NIPO appl.
1. A nitride-based semiconductor device comprising: a first semiconductor layer, consisting of either an n-type nitride-based semiconductor layer having a wurtzite structure or an n-type nitride-based semiconductor substrate having a wurtzite structure; and an n-side electrode formed on a back surface of said first semiconductor layer, wherein a dislocation density is not more than $1 \times 10^9 \text{cm}^{-2}$ in the vicinity of the interface between said first semiconductor layer and said n-side electrode, and contact resistance between said n-side electrode and said first semiconductor layer is not more than $0.05 \Omega \text{cm}^2$	1. (Same)
2. (None)	2. <i>The nitride-based semiconductor device according to claim 1, wherein said first semiconductor layer includes an n-type dopant* .</i>

*This additional part is NOT included in the allowable claim but it is included in the description of the national claim

ANNEX 2

A A case meeting requirement (a) (i)
- Paris route -

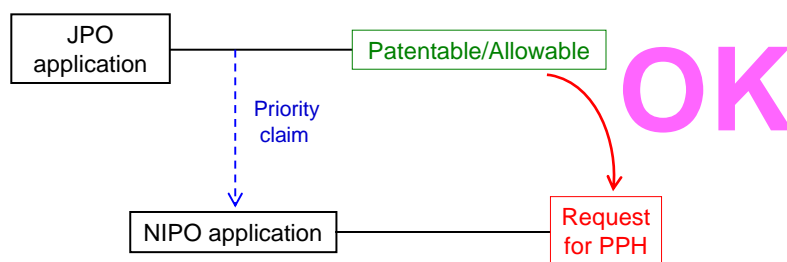

B A case meeting requirement (a) (i)
- PCT route -

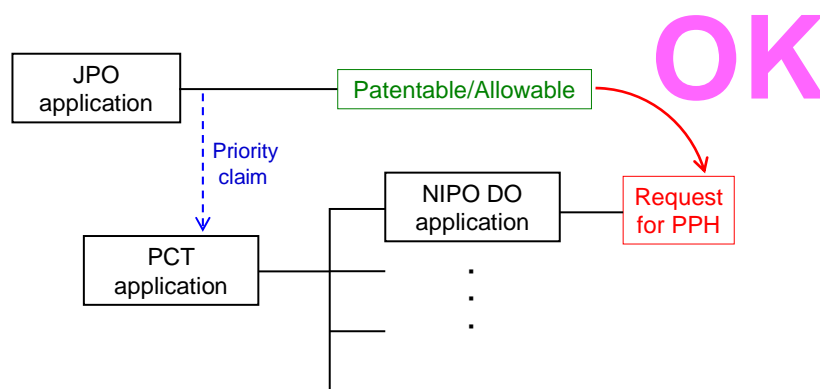

C

A case meeting requirement (a) (i)

- PCT route, Domestic priority -

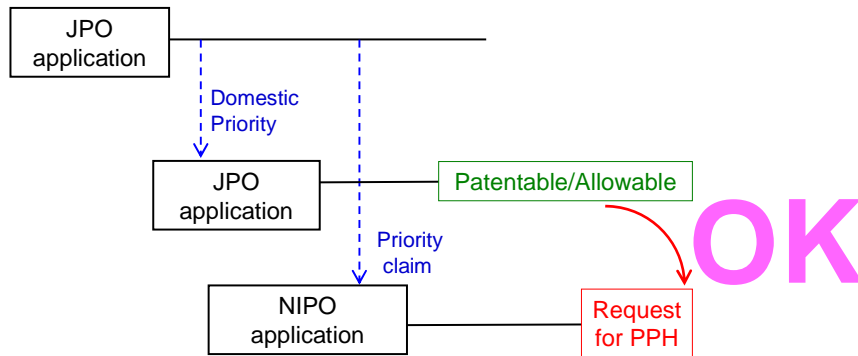

D

A case not meeting requirement (a)

- Paris route, but the first application is from the third country -

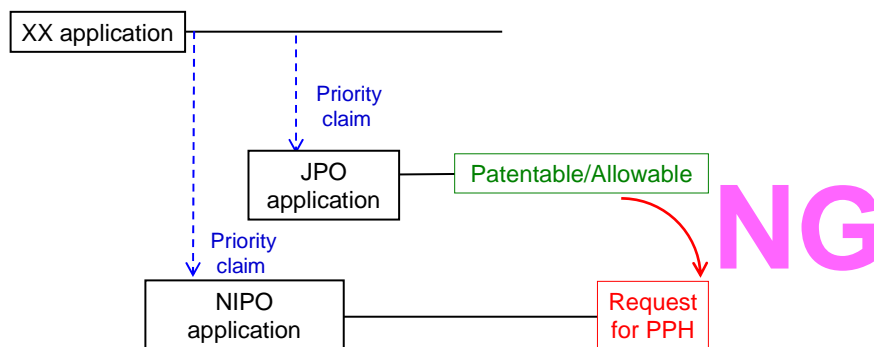

XX : the office other than the JPO

E A case not meeting requirement (a)
- PCT route, but the first application is from the third country -

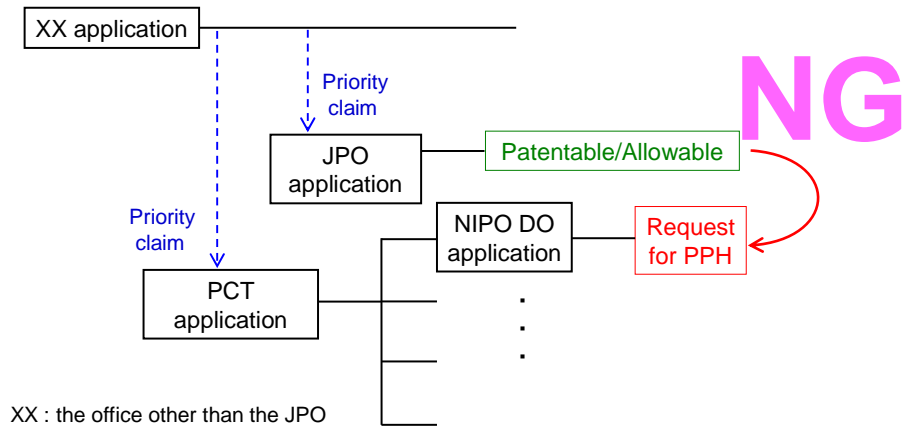

F A case meeting requirement (a) (i)
- Paris route & Complex priority -

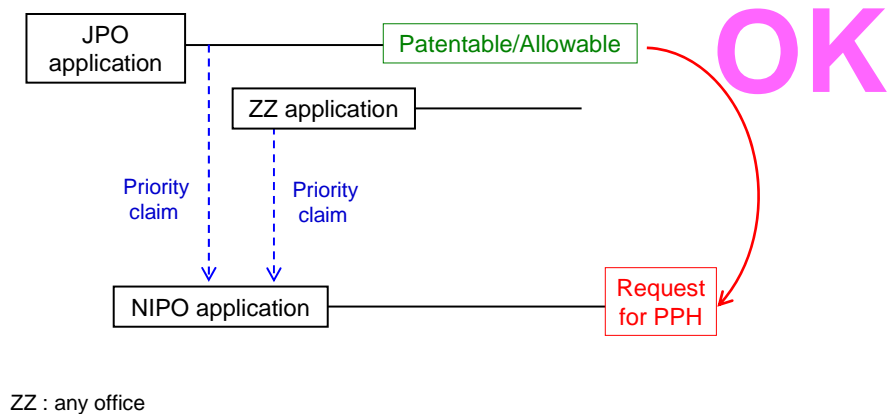

G A case meeting requirement (a) (i)
- Paris route & divisional application -

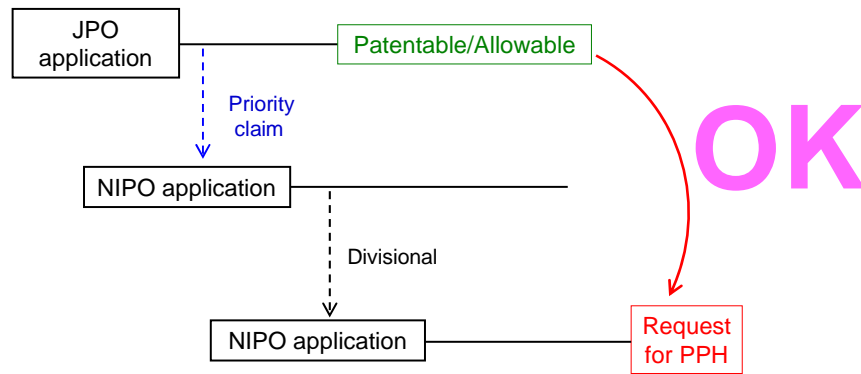

H A case meeting requirement (a) (i)
- PCT route -

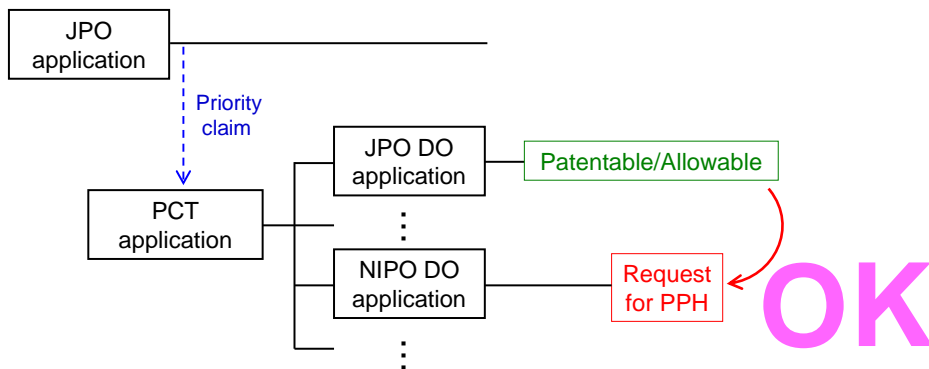

I A case meeting requirement (a) (ii)
- Direct PCT route -

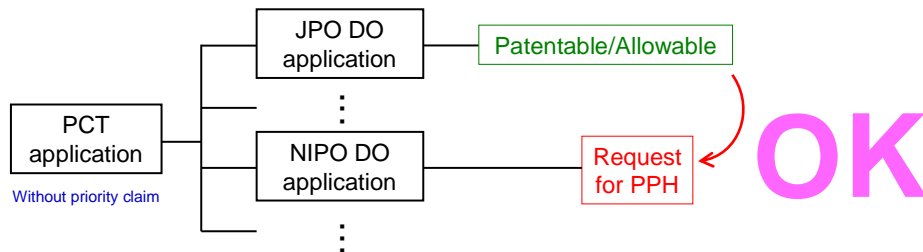

J A case meeting requirement (a) (iii)
- Direct PCT & Paris route -

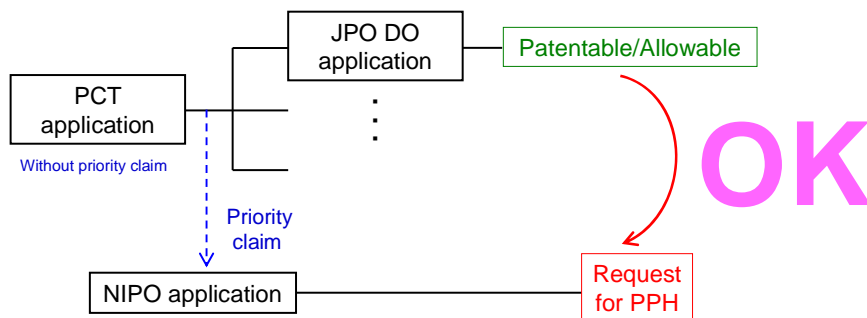

K A case meeting requirement (a) (iii)
- Direct PCT & PCT route -

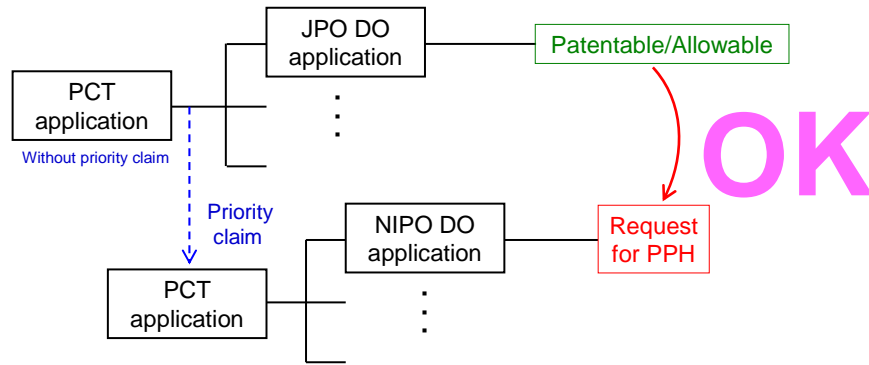

L A case meeting requirement (a) (iii)
- Direct PCT & PCT route -

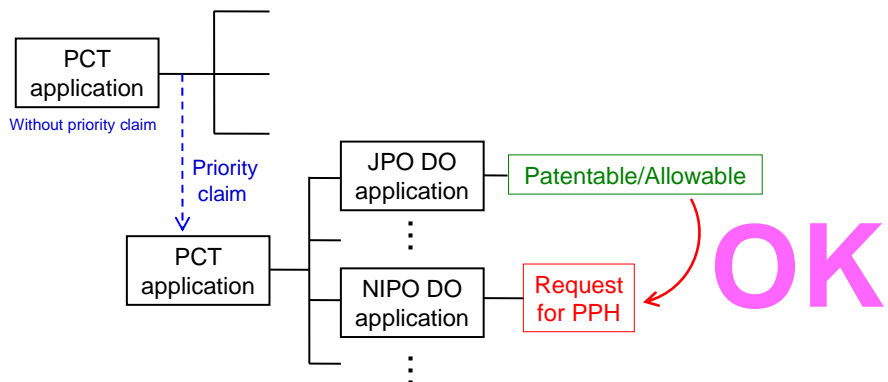

M A case not meeting requirement (d)
- Examination has begun before a request for PPH -

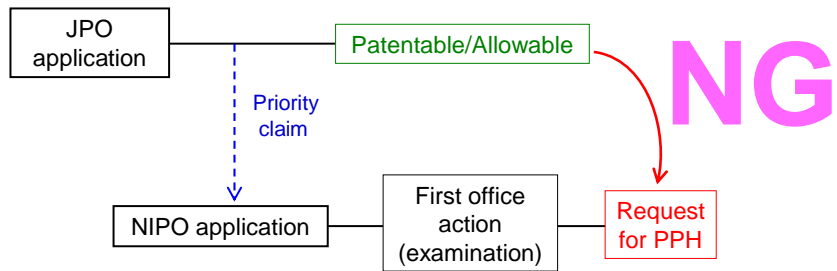

ANNEX 3

PPH REQUEST

Request for Accelerated Examination at the Norwegian Industrial Property Office (NIPO) under the Patent Prosecution Highway Pilot Program Between the NIPO and the Japan Patent Office (JPO)

- 1 NO application number: —
Corresponding JP application number(s):
- 2 **Either:**
- a) Copy of JP office action(s) in Japanese attached:
and
Copy of JP office action(s) translated into English or Norwegian attached
or
- b) NIPO to obtain JP office action(s) from AIPN:
or
- c) JP office action(s) on file from previous PPH request:
NO application number:
- 3 **Either:**
- a) Copy of claims indicated to be allowable of corresponding JP application attached:
and
Copy of JP claims translated to English or Norwegian attached:
or
- b) NIPO to obtain JP claims from AIPN:
or
- c) JP application claims on file from previous PPH request:
NO application number:
- 4 Claim correspondence table attached:
- 5 Copies of all documents cited by the JPO (except for patent documents) attached:

JPO claims	NIPO claims	Comments explaining the correspondence

Please ensure that this is the uppermost document when requesting accelerated examination under the PPH.

ANNEX 4

Examples for the claim correspondence table

The claims in the following cases are considered to “sufficiently correspond”.

EX.1

<i>Claims in the international phase</i>	<i>NIPO claims</i>	<i>Comments</i>
1	1	<i>The NIPO claim has the additional component on the claim that is determined to be patentable by JPO.</i>

Allowable claim, corresponding PCT appl.	Claim, national appl.
<p>A system for presenting a container storing at least one article to a processing tool, comprising:</p> <p>(a) a load port, including:</p> <p>a frame having an opening;</p> <p>a support structure being adapted to receive a container, and</p> <p>a drive mechanism for moving said support structure substantially vertically between a first height and a second height; and</p> <p>(b) a conveyor for movably supporting the container substantially along a container transport plane;</p> <p>wherein a container traveling on said conveyer moves unobstructed over said support structure when said support structure is located in said second height,</p> <p>wherein the container traveling unobstructed does not contact said support structure while traveling over said support structure located at said second height,</p> <p>wherein said support structure, when located at said second height, is located below said transport plane.</p> <p><u>*This additional part is NOT included in the allowable claim but it is included in the description of the national claim</u></p>	<p>A system for presenting a container storing at least one article to a processing tool, comprising:</p> <p>(a) a load port, including:</p> <p>a frame having an opening;</p> <p>a support structure being adapted to receive a container, and</p> <p>a drive mechanism for moving said support structure substantially vertically between a first height and a second height; and</p> <p>(b) a conveyor for movably supporting the container substantially along a container transport plane;</p> <p>wherein a container traveling on said conveyer moves unobstructed over said support structure when said support structure is located in said second height,</p> <p>wherein the container traveling unobstructed does not contact said support structure while traveling over said support structure located at said second height,</p> <p>wherein said support structure, when located at said second height, is located below said transport plane,</p> <p><u>wherein said support structure, when located at said first height, is located above said transport plane*</u></p>

EX.2

<i>Claims in the international phase</i>	<i>NIPO claims</i>	<i>Comments</i>
<i>1</i>	<i>1</i>	<i>Same</i>
<i>none</i>	<i>2</i>	<i>The NIPO claim2 is dependent on the NIPO claim1, which has been determined to be patentable by JPO.</i>

Allowable claim, corresponding PCT appl.	Claim, national appl.
1. A nitride-based semiconductor device comprising: a first semiconductor layer, consisting of either an n-type nitride-based semiconductor layer having a wurtzite structure or an n-type nitride-based semiconductor substrate having a wurtzite structure; and an n-side electrode formed on a back surface of said first semiconductor layer, wherein a dislocation density is not more than $1 \times 10^9 \text{cm}^{-2}$ in the vicinity of the interface between said first semiconductor layer and said n-side electrode, and contact resistance between said n-side electrode and said first semiconductor layer is not more than $0.05 \Omega \text{cm}^2$	1. (Same)
3. (None)	2. <i>The nitride-based semiconductor device according to claim 1, wherein said first semiconductor layer includes an n-type dopant* .</i>

*This additional part is NOT included in the allowable claim but it is included in the description of the national claim

ANNEX 5

(A) The application is a national phase application of the corresponding international application.

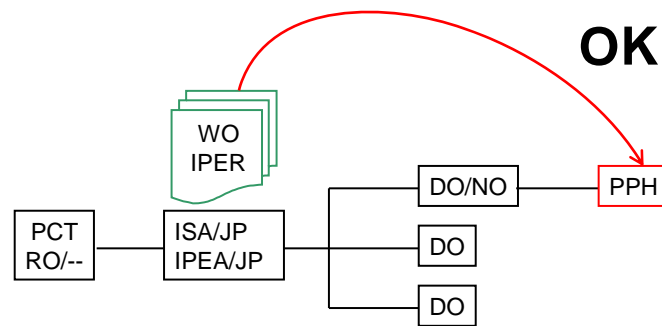

(A') The application is a national phase application of the corresponding international application.

(The corresponding international application claims priority from a national application.)

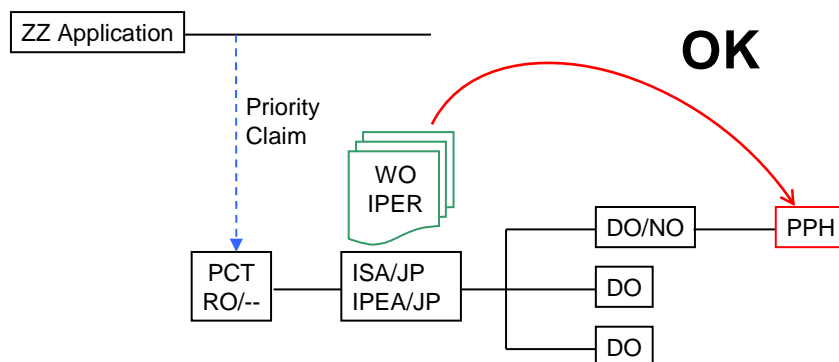

ZZ=any office

(A'') The application is a national phase application of the corresponding international application.

(The corresponding international application claims priority from an international application.)

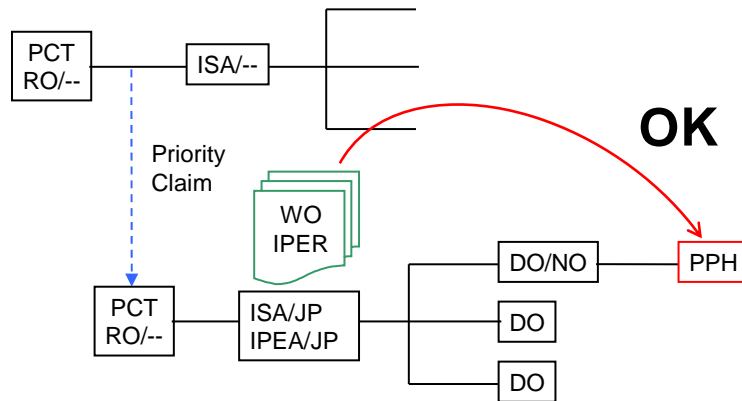

(B) The application is a national application as a basis of the priority claim of the corresponding international application.

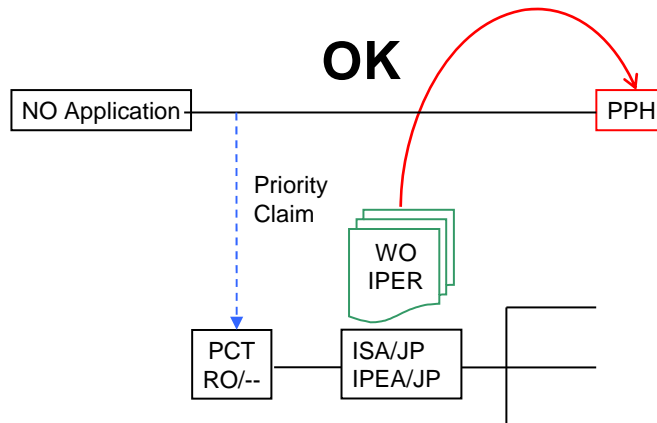

(C) The application is a national phase application of an international application claiming priority from the corresponding international application.

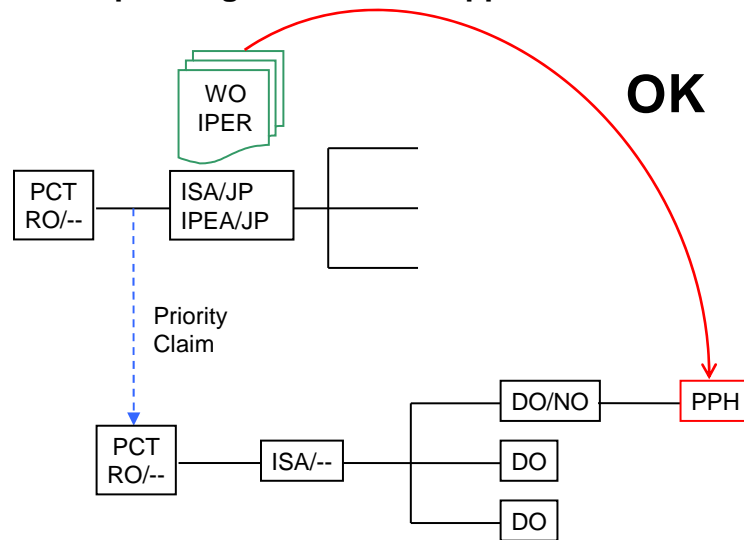

(D) The application is a national application claiming foreign/domestic priority from the corresponding international application.

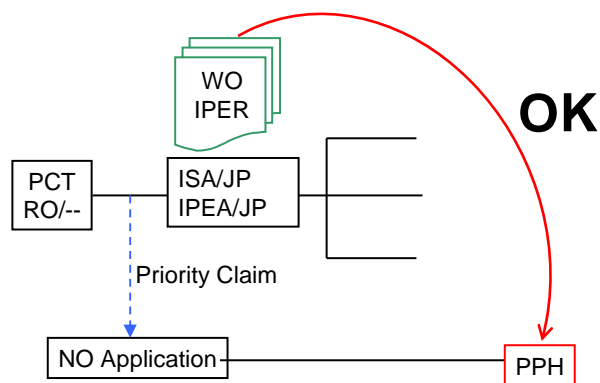

(E1) The application is a divisional application of an application which satisfies the requirement (A).

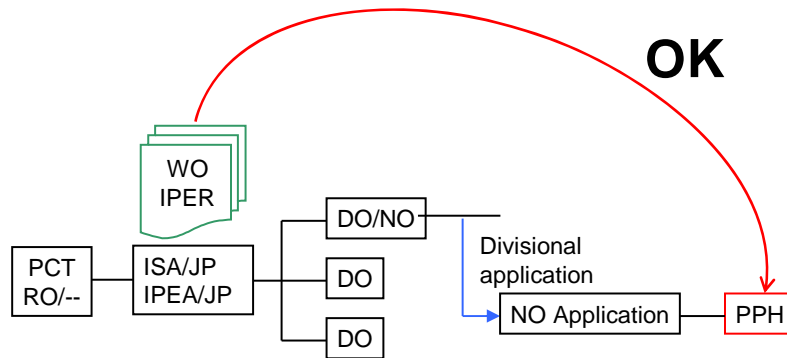

(E2) The application is an application claiming domestic priority from an application which satisfies the requirement (B).

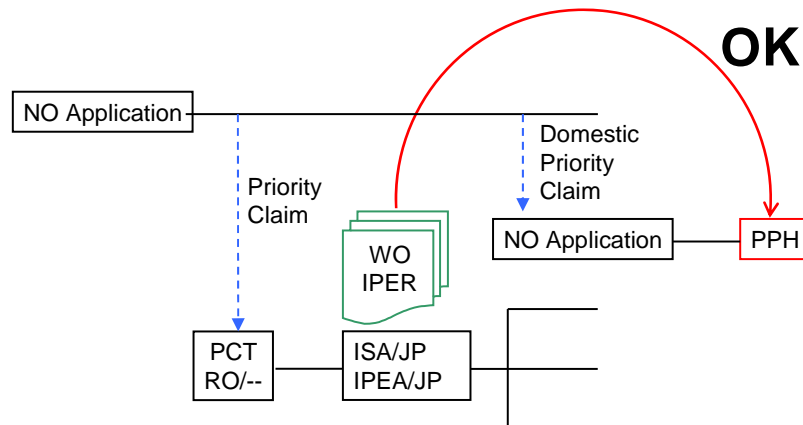

ANNEX 6

PCT-PPH REQUEST

Request for Accelerated Examination at the Norwegian Industrial Property Office (NIPO) using the PCT international work products under the Patent Prosecution Highway Pilot Program Between the NIPO and the Japan Patent Office (JPO)

- 1 NO application number: _
Corresponding PCT application number(s):
- 2 **Either:**
- a) Copy of WO-ISA, WO-IPEA or IPER attached:
- and**
- Copy of WO-ISA, WO-IPEA or IPER translated into English or Norwegian attached:
- or**
- b) NIPO to obtain documents in a) via PATENTSCOPE®:
- or**
- c) Copy of documents in a) on file from previous PPH request:
NO application number:
- 3 **Either:**
- a) Copy of claims indicated to be allowable by the ISA or IPEA attached:
- or**
- b) NIPO to obtain documents in a) via PATENTSCOPE®:
- or**
- c) Copy of documents in a) on file from previous PPH request:
NO application number:
- and**
- Copy of claims indicated to be allowable by the ISA or IPEA translated to English or Norwegian attached:
- 4 Claim correspondence table attached:
- 5 Copies of all documents cited by the ISA or IPEA (except for patent documents) attached:

Claims in the international phase	NIPO claims	Comments explaining the correspondence

Please ensure that this is the uppermost document when requesting accelerated examination under the PCT-PPH.