

**Procedures to file a request to the JPO for
Patent Prosecution Highway Pilot Program
using the PCT international work products from the JPO**

Applicants can request accelerated examination by a prescribed procedure including submission of relevant documents on an application which is filed with the Japan Patent Office (JPO) and satisfies the following requirements under the JPO Patent Prosecution Highway pilot programs based on PCT international work products (PCT-PPH pilot program).

When filing a request for the PCT-PPH pilot program, an applicant must submit a request form “The Explanation of Circumstances Concerning Accelerated Examination” based on the procedure prescribed in “the Guidelines of the Accelerated Examination and Appeal.”¹ Under the PCT-PPH Pilot program, an applicant is not required to fill in the section “2. the disclosure of prior arts and comparison between the claimed invention and prior art” in “The Explanation of Circumstances Concerning Accelerated Examination”.

The trial period of the PCT-PPH pilot program will commence on January 29,, 2012, for a trial period duration of two years and ending on January 28, 2014.

The trial period may be extended if necessary until the JPO receives the sufficient number of PCT-PPH requests to adequately assess the feasibility of the PCT-PPH pilot program.

The Office may also terminate the PCT-PPH pilot program early if the volume of participation exceeds manageable level, or for any other reason. Notice will be published if the PCT-PPH pilot program is terminated before 28 January 2014.

1. Requirements

The application which is filed with the JPO and on which the applicant files a request under the PCT-PPH must satisfy the following requirements:

- (1) The latest work product in the international phase of a PCT application corresponding to the application (“international work product”), namely the Written Opinion of International Search Authority (WO/ISA), the Written Opinion of International Preliminary Examination Authority (WO/IPEA) or the

¹ http://www.jpo.go.jp/torikumi/t_torikumi/souki/pdf/v3souki/guideline.pdf
“The Explanation of Circumstances Concerning Accelerated Examination” is described on pages 31-33.

International Preliminary Examination Report (IPER), indicates at least one claim as allowable (from the aspect of novelty, inventive steps and industrial applicability).

Note that the ISA and the IPEA which produced the WO/ISA, WO/IPEA and the IPER are limited to the JPO, but, if priority is claimed, the priority claim can be to an application in any Office, see example A' in Annex (application ZZ can be any national application).

The applicant cannot file a request under PCT-PPH on the basis of an International Search Report (ISR) only.

In case any observation is described in Box VIII of WO/ISA, WO/IPEA or IPER which forms the basis of a PCT-PPH request, the applicant must identify and explain which claim(s) is/are allowable whether or not an amendment is submitted to correct the observation noted in Box VIII. The application will not be eligible for participating in PCT-PPH pilot program if the applicant does not identify and explain which claim(s) is/are allowable. In this regard, however, it does not affect the decision on the eligibility of the application whether the explanation is adequate and/or whether the amendment submitted overcomes the observation noted in Box VIII.

- (2) The relationship between the application and the corresponding international application satisfies one of the following requirements:
 - (A) The application is a national phase application of the corresponding international application. (See Diagrams A, A', and A'' in Annex)
 - (B) The application is a national application as a basis of the priority claim of the corresponding international application. (See Diagram B in Annex)
 - (C) The application is a national phase application of an international application claiming priority from the corresponding international application. (See Diagram C in Annex)
 - (D) The application is a national application claiming foreign/domestic priority from the corresponding international application. (See Diagram D in Annex)
 - (E) The application is the derivative application (divisional application and application claiming domestic priority etc.) of the application which satisfies one of the above requirements (i) – (iv). (See Diagrams E1 and E2 in Annex)

- (3) All claims on file, as originally filed or as amended, for examination under the

PCT-PPH must sufficiently correspond to one or more of those claims indicated to be allowable in the latest international work product of the corresponding international application.

Claims are considered to "sufficiently correspond" where, accounting for differences due to translations and claim format, the claims of the application are of the same or similar scope as the claims indicated to be allowable in the latest international work product, or the claims of the application are narrower in scope than the claims indicated to be allowable in the latest international work product.

In this regard, a claim that is narrower in scope occurs when a claim indicated to be allowable in the latest international work product is amended to be further limited by an additional feature that is supported in the specification (description and/or claims) of the application.

A claim of the application which introduces a new/different category of claims to those claims indicated to be allowable in the latest international work product is not considered to sufficiently correspond. For example, the claims indicated to be allowable in the latest international work product only contain claims to a process of manufacturing a product, then the claims of the application are not considered to sufficiently correspond if the claims of the application introduce product claims that are dependent on the corresponding process claims.

- (4) The JPO has not begun examination of the application at the time of request under PCT-PPH.

2. Documents to be submitted

The applicant is required to attach a claims correspondence table which indicates how all claims in the application sufficiently correspond to the claims indicated to be allowable in the latest international work product to the request form. It is necessary to explain the sufficient correspondence of each claim based on the criteria 1. (3) in the table (please refer to the **Example form** below).

If all claims in the corresponding international application which is in Japanese are indicated to be allowable in the latest international work product and all claims in the application for which the PPH is requested are completely the

same as all claims in corresponding international application (i.e. claims of both applications are literally identical to each other without deletion, addition or rearrangement of claims), the applicant can just write down that both claims are the same on the request form and thereby will not be required to attach the above claims correspondence table.

3. Example of “The Explanation of Circumstances Concerning Accelerated Examination” for filing request an accelerated examination under the PCT-PPH pilot program

(1) Circumstances

The applicant must indicate that the application is included in (A) to (E) of 1. (2), and that the accelerated examination is requested under the PCT-PPH pilot program. The application number(s) of the corresponding international application(s) also must be written.

In case any observation is described in Box VIII of WO/ISA, WO/IPEA or IPER which forms the basis of a PCT-PPH request, the applicant must identify and explain which claim(s) is/are allowable.

(2) Documents to be submitted

The applicant must list the required document mentioned above 2. in an identifiable way.

(3) Notice

Forms of “The Explanation of Circumstances Concerning Accelerated Examination” are different between on-line procedure and paper procedure. Please refer to the examples of forms when filling in (“Form 1 for Accelerated Examination” for on-line procedures, and “Form 2 for Accelerated Examination” for paper procedures.).

Example form of on-line procedures

【書類名】 早期審査に関する事情説明書

The name of this paper

【提出日】 平成00年00月00日

Date of filing

【あて先】 特許庁長官殿

Destination

【事件の表示】

【出願番号】 特願 0000-000000

Application number

【提出者】

【識別番号】 000000000

【住所又は居所】 ○○県○○市○丁目

【氏名又は名称】 ○○○○

The name and address of who submit this

【代理人】

【識別番号】 000000000

【住所又は居所】 ○○県○○市○丁目

【氏名又は名称】 ○○ ○○

The name and address of the attorney

Bibliographical items

【早期審査に関する事情説明】

The explanation of circumstances concerning accelerated examination

1. 事情

本出願は国際出願(出願番号 PCT/JP0000/000000)の国内移行出願であり、特許審査ハイウェイに基づく早期審査の申請を行うものである。

当該国際出願について国際調査機関としての日本国特許庁が作成した見解書において、特許請求の範囲に対し特許可能との判断が明示されている。

1. Circumstances

This application is a national phase application of a PCT international application (the application number is PCT/JP0000/000000), and the accelerated examination is requested under the PPH program.

The WO/ISA issued by the JPO as an ISA indicates at least one claim to be allowable.

【提出物件の目録】

The list of submitted documents

【物件名】 国際出願と本出願の請求項の対応関係を示す書面 1

The table to explain how the claims indicated as allowable in the international phase sufficiently correspond to the claims in the JP application 1

If the name of the document is long (over than 50 letters), it is impossible to write it down directly to the column “【物件名】.” Please write down the full name of the document in the column “【早期審査に関する事情説明】” and name it properly. Then write the name in the column “【物件名】.”

Use the same name as “【物件名】” under “【提出物件の目録】.”

Attach the document here as image file or text.

【添付物件】

The list of attached documents

【物件名】 国際出願と本出願の請求項の対応関係を示す書面

The table to explain how the claims indicated as allowable in the international phase sufficiently correspond to the claims in the JPO application

【内容】

本出願の請求項	国際段階で特許可能とされた請求項	対応関係に関するコメント
The claim in the JPO	The allowable claim in the international phase	Comments about the correspondence
1	1	両クレームは同一である。 Both claims are the same.
2	2	”
3	1	両クレームは、記載形式を除き同一である。 Both claims are the same except the claim format.
4	2	”
5	1	請求項5は、国際段階の請求項1にAという構成を付加したものである。 The claim 5 in the JPO has additional composition A on the Claim 1 in the international phase.

Note that in the case of paper procedure, the pendency period (the period between the request for PPH and the first office action) tends to be longer than on-line procedure.

(A) The application is a national phase application of the corresponding international application.

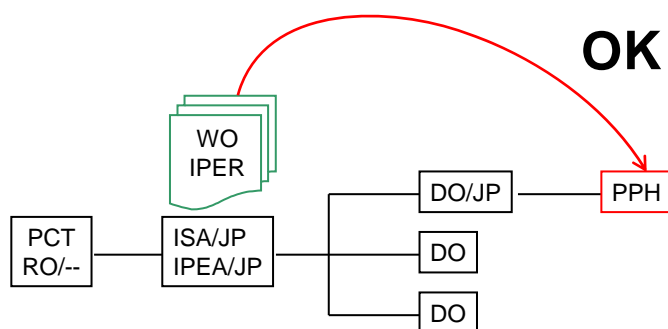

(A') The application is a national phase application of the corresponding international application.
 (The corresponding international application claims priority from a national application.)

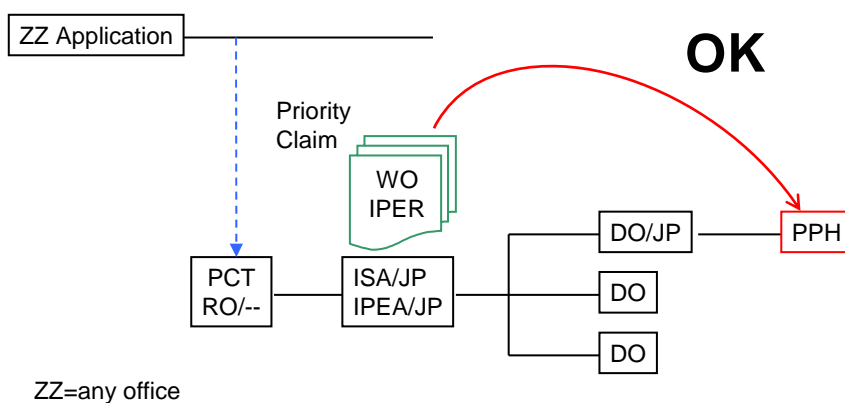

(A'') The application is a national phase application of the corresponding international application.
 (The corresponding international application claims priority from an international application.)

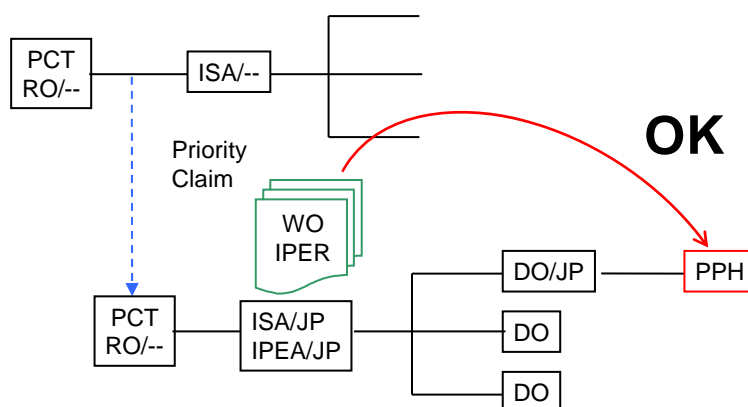

(B) The application is a national application as a basis of the priority claim of the corresponding international application.

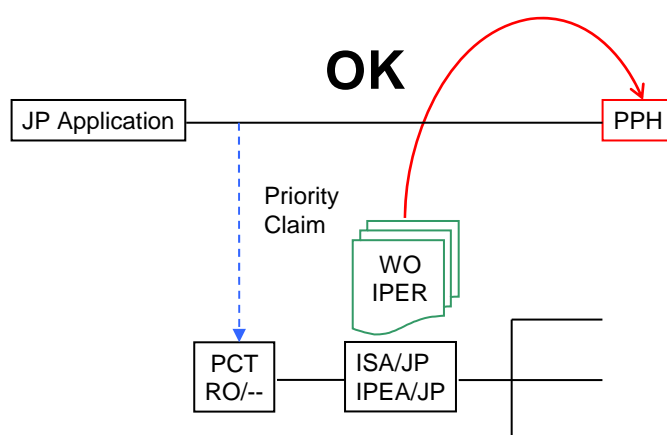

(C) The application is a national phase application of an international application claiming priority from the corresponding international application.

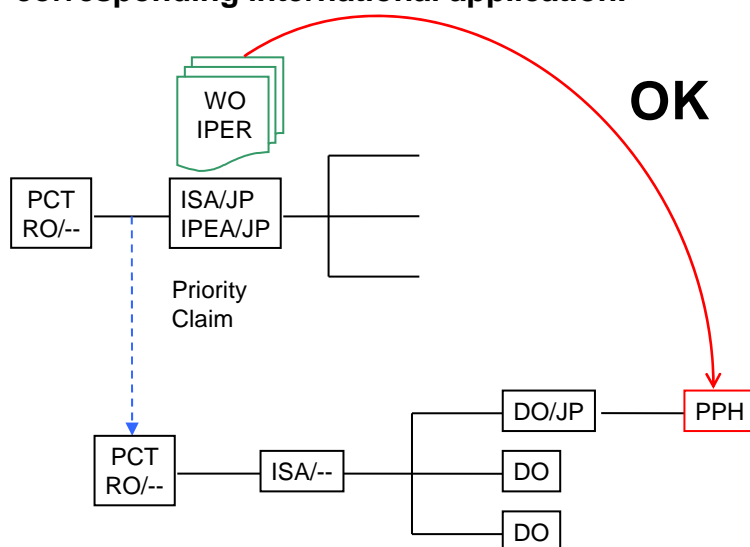

(D) The application is a national application claiming foreign/domestic priority from the corresponding international application.

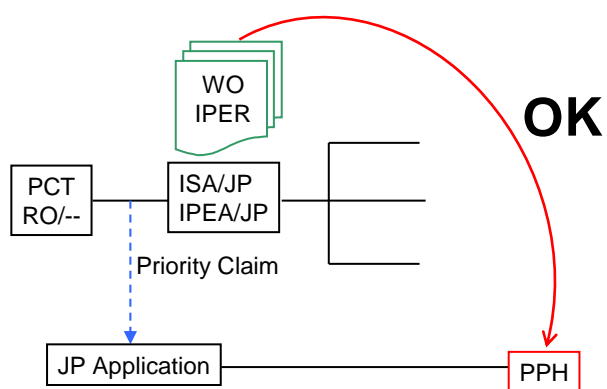

(E1) The application is a divisional application of an application which satisfies the requirement (A).

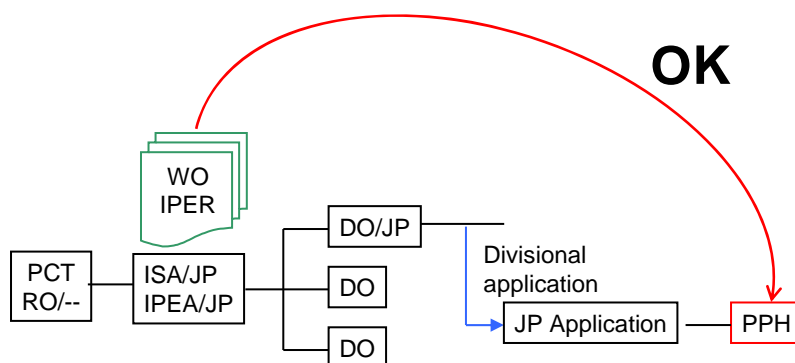

(E2) The application is an application claiming domestic priority from an application which satisfies the requirement (B).

