

Procedures to file a request to the JPO (Japan Patent Office) for Patent Prosecution Highway Pilot Program between the JPO and the SIPO (State Intellectual Property Office of the P. R. China)

The pilot period of this PPH pilot program will commence on November 1, 2011, for a duration of one year and ending on October 31, 2012. The pilot period may be extended if necessary until the SIPO and JPO receive the sufficient number of PPH requests to adequately assess the feasibility of PPH program.

The Offices may also terminate the PPH pilot program if the volume of participation exceeds manageable level, or for any other reason. Ex Ante notice will be published if the PPH pilot program is terminated.

Part I **PPH using the national work products from the SIPO**

Applicants can request accelerated examination by a prescribed procedure including submission of relevant documents on an application which is filed with the JPO and satisfies the following requirements under the JPO-SIPO Patent Prosecution Highway (PPH) pilot program based on the SIPO application.

When filing a request for the PPH pilot program, an applicant must submit a request form "The Explanation of Circumstances Concerning Accelerated Examination" based on the procedure prescribed in "the Guidelines of the Accelerated Examination and Appeal"¹. Under the PPH pilot program, an applicant is not required to fill in the section "2. the disclosure of prior arts and comparison between the claimed invention and prior art" in "The Explanation of Circumstances Concerning Accelerated Examination".

1. Requirements

- (a) The JPO application (including PCT national phase application) is**
- (i) an application which validly claims priority under the Paris Convention to the SIPO application(s) (examples are provided in ANNEX I, Figure A, B, C, F, G and H), or**
 - (ii) a PCT national phase application without priority claim (examples are provided in Annex I, Figure I and K), or**
 - (iii) an application which validly claims priority under the Paris Convention to the PCT application(s) without priority claim (examples are provided in ANNEX I, Figure J and L).**

¹ http://www.jpo.go.jp/torikumi/t_torikumi/souki/pdf/v3souki/guideline.pdf

The JPO application, which validly claims priority to multiple SIPO or direct PCT applications, or which is the divisional application validly based on the originally filed application that is included in (i) to (iii) above, is also eligible.

(b) At least one corresponding application exists in the SIPO and has one or more claims that are determined to be patentable/allowable by the SIPO.

The corresponding application(s) can be the application which forms the basis of the priority claim, an application which derived from the SIPO application which forms the basis of the priority claim (e.g., a divisional application of the SIPO application or an application which claims domestic priority to the SIPO application (see Figure C in Annex I)), or a SIPO national phase application of a PCT application (see Figures H, I, J, K and L in Annex I). Claims are “determined to be allowable/patentable” when the SIPO examiner explicitly identified the claims to be allowable/patentable in the latest office action, even if the application is not granted for patent yet.

The office action includes:

- (a) Decision to Grant a Patent,
- (b) First/Second/Third/…… Office Action,
- (c) Decision of Refusal,
- (d) Reexamination Decision, and
- (e) Invalidation Decision.

Claims are also “determined to be allowable/patentable” in the following circumstances: If the SIPO office action does not explicitly state that a particular claim is allowable/patentable, the applicant must include explanation accompanying the request for participation in the PPH pilot program that no rejection has been made in the SIPO office action regarding that claim, and therefore, the claim is deemed to be allowable/patentable by the SIPO.

For example, if claims are not shown in the item of “6. the Opinion on the Conclusion of Examination (審查的結論性意見) about Claims (權利要求書)” in the “First Notice of the Opinion on Examination(第一次審查意見通知書)” or “5. the Opinion on the Conclusion of Examination (審查的結論性意見) about Claims (權利要求書)” in the “Second/Third/... Notice of the Opinion on Examination(第二次審查意見通知書)” of the SIPO, those claims may be deemed to be implicitly identified to be allowable/patentable and then the applicant must include the above explanation.

(c) All claims in the JPO application (for which an accelerated examination under the PPH pilot program is requested) must sufficiently correspond to one or more of those claims determined to be patentable/allowable in the SIPO.

Claims are considered to “sufficiently correspond” where, accounting for differences due to

translations and claim format, the claims in the JPO are of the same or similar scope as the claims in the SIPO, or the claims in the JPO are narrower in scope than the claims in the SIPO. In this regard, a claim that is narrower in scope occurs when a SIPO claim is amended to be further limited by an additional technical feature that is supported in the specification (description and/or claims). A claim in the JPO which introduces a new/different category of claims to those claims determined to be patentable/allowable in the SIPO is not considered to sufficiently correspond. For example, the SIPO claims only contain claims to a process of manufacturing a product, then the claims in the JPO are not considered to sufficiently correspond if the JPO claims introduce product claims that are dependent on the corresponding process claims.

It is not necessary to include "all" claims determined to be patentable/allowable in the SIPO in an application in the JPO (the deletion of claims is allowable). For example, in the case where an application in the SIPO contains 5 claims determined to be patentable/allowable, the application in the JPO may contain only 3 of these 5 claims.

Any claims amended or added after the grant of the request for participation in the PPH pilot program need not to sufficiently correspond to the claims indicated as patentable/allowable in the SIPO application.

- (d) The JPO has not begun examination of the application at the time of request for the PPH.***

2. Documents to be submitted

Documents (a) to (d) below must be submitted by attaching to "The Explanation of Circumstances Concerning Accelerated Examination".

Note that even when it is not needed to submit documents below, the name of the documents must be listed in "The Explanation of Circumstances Concerning Accelerated Examination" (Please refer to the Example form for the detail).

- (a) Copies of all office actions (which are relevant to substantial examination for patentability in the SIPO), which were sent for the corresponding application by the SIPO, and translations of them.***

Either Japanese or English is acceptable as translation language. Machine translation will be admissible, but if it is impossible for the examiner to understand the outline of the translated office action due to insufficient translation, the examiner can request the applicant to resubmit translations.

- (b) Copies of all claims determined to be patentable/allowable by the SIPO, and***

translations of them.

Either Japanese or English is acceptable as translation language. Machine translations will be admissible, but if it is impossible for the examiner to understand the outline of the translated claims due to insufficient translation, the examiner can request the applicant to resubmit translations.

(c) *Copies of references cited by the SIPO examiner*

The documents to be submitted are those cited in the above-mentioned office actions. Documents which are only referred to as references and consequently do not consist of the reasons for refusal do not have to be submitted.

If the references are patent documents, the applicant doesn't have to submit them because the JPO usually possesses them. When the JPO does not possess the patent document, the applicant has to submit the patent document at the examiner's request. Non-patent literature must always be submitted. The translations of the references are unnecessary.

(d) *Claim correspondence table*

The applicant requesting PPH must submit a claim correspondence table, which indicates how all claims in the JPO application sufficiently correspond to the patentable/allowable claims in the SIPO application.

When claims are just literal translation, the applicant can just write down that "they are the same" in the table. When claims are not just literal translation, it is necessary to explain the sufficient correspondence of each claim based on the criteria 1. (c) (Please refer to the Example form).

When the applicant has already submitted above documents (a) to (d) to the JPO through simultaneous or past procedures, the applicant may incorporate the documents by reference and does not have to attach them.

3. Example of "The Explanation of Circumstances Concerning Accelerated Examination" for filing request for an accelerated examination under the PPH pilot program

(1) Circumstances

When an applicant files a request for an accelerated examination under the PPH pilot program

to the JPO, an applicant must submit a request form “The Explanation of Circumstances Concerning Accelerated Examination” based on the procedure prescribed in “the Guidelines of the Accelerated Examination and Appeal”².

The applicant must indicate that the application is included in (i) to (iii) of 1. (a), and that the accelerated examination is requested under the PPH pilot program. The application number, publication number, or a patent number of the corresponding SIPO application(s) also must be written.

*In the case that the application which has one or more claims that are determined to be patentable/allowable is different from the SIPO application(s) included in (i) to (iii) of 1. (a) (for example, the divisional application of the basic application), the application number, publication number, or a patent number of the application(s) which has claims determined to be patentable/allowable and the relationship between those applications also must be written.

(2) Documents to be submitted

The applicant must list all required documents mentioned above 2. in an identifiable way, even when applicant omits to submit certain documents.

(3) Notice

Please refer to the example of the form of “The Explanation of Circumstances Concerning Accelerated Examination” for both on-line and paper procedures.

Note that in the case of paper procedure, the pendency period (the period between the request for PPH and the first office action) tends to be longer than on-line procedure.

4. Procedure for the accelerated examination under the PPH pilot program

The JPO decides whether the application can be entitled to the status for an accelerated examination under the PPH when it receives a request with the documents stated above. When the JPO decides that the request is acceptable, the application is assigned a special status for an accelerated examination under the PPH.

In those instances where the request does not meet all the requirements set forth above, the applicant will be notified and the defects in the request will be identified. Before the issue of the notification of not assigning a special status for accelerated examination under the PPH, the applicant will be given opportunity to submit missing documents. Even after the issue of the notification of not assigning a special status for accelerated examination under the PPH, the

² http://www.jpo.go.jp/torikumi/t_torikumi/souki/pdf/v3souki/guideline.pdf

Part I PPH using the national work products from the SIPO

applicant can request the PPH again.

Example form of “The Explanation of Circumstances Concerning Accelerated Examination”

【書類名】 早期審査に関する事情説明書 The name of this paper	} Bibliographical items
【提出日】 平成00年00月00日 Date of filing	
【あて先】 特許庁長官殿 Destination	
【事件の表示】 【出願番号】 特願 0000-000000 Application number	
【提出者】 【識別番号】 000000000 【住所又は居所】 〇〇県〇〇市〇丁目 【氏名又は名称】 〇〇〇〇〇 The name and address of who submit this	
【代理人】 【識別番号】 000000000 【住所又は居所】 〇〇県〇〇市〇丁目 【氏名又は名称】 〇〇 〇〇 The name and address of the attorney	
【早期審査に関する事情説明】 The explanation of circumstances concerning accelerated examination	
1. 事情 本出願は中国国家知識産権局への出願(特許出願番号 P0000-00000)をパリ条約に基づく優先権の基礎出願とする出願であり、特許審査ハイウェイ試行プログラムに基づく早期審査の申請を行うものである。	
1. Circumstances This application is an application validly claiming the priority under the Paris Convention to the corresponding SIPO application (the application number is 000000000), and the accelerated examination is requested under the PPH pilot program.	
以下において、「引用非特許文献1」とは、「村岡洋一著、「コンピュータサイエンス大学講座(第11巻) コンピュータ・アーキテクチャ」、第2版、株式会社近代科学者、1985年11月、p.123-127」である。	
In what follows, “non-patent literature1” is “Yoichi Muraoka, Lecture of Computer Science (vol.11) computer architecture, 2 nd edition, Scientist com, Nov. 1985, p.123-127.”	
<In case of on-line procedure> If the name of the document is long (over than 50 letters), it is impossible to write it down directly to the column “【物件名】.” Please write down the full name of the document in the column “【早期審査に関する事情説明】” and name it properly. Then write the name in the column “【物件名】.”	

(提出を省略する物件)

(物件名) 対応中国出願に対して引用された中国出願公開00000号公報

(物件名) 対応中国出願に対して引用された日本国特許第00000号公報

List up the documents which can be omitted to submit

(Documents to be omitted to submit)

(The name of the document) Cited reference of the corresponding SIPO application:
Chinese Publication of application 0000000

(The name of the document) Cited reference of the corresponding SIPO application:
Japan Patent publication of application 0000000

【提出物件の目録】

List up the documents to be submitted

The list of submitted documents

【物件名】 中国出願と本出願の請求項の対応関係を示す書面 1

【物件名】 対応中国出願に対する**年**月**日付の第一次審査意見通知書の写し及びその翻訳文 1

【物件名】 対応中国出願に対する**年**月**日付の特許査定およびその翻訳文 1

【物件名】 対応中国出願で特許可能と判断された請求項の写し及びその翻訳文 1

【物件名】 引用非特許文献 1

(The name of the document) The table to explain how the claims indicated as allowable in the SIPO sufficiently correspond to the claims in the JPO application 1

(The name of the document) Copy and translation of the First Notice of the Opinion on Examination in the SIPO on (date) 1

(The name of the document) Copy and translation of grant in the SIPO on (date) 1

(The name of the document) Copy and translation of the claims indicated patentable in the report on the state of the art and written opinion in the SIPO on (date) 1

(The name of the document) Cited non patent literature 1

<In case of on-line procedure> The applicants can describe the list of attached documents as below.
 <In case of paper procedure> The applicants have to describe the following not on this form but on accompanying sheets at each attached document.

Use the same name as “【物件名】” under “【提出物件の目録】.”

Attach the document here as image file or text.

【添付物件】

The list of attached documents

【物件名】 中国出願と本出願の請求項の対応関係を示す書面

The table to explain how the claims indicated as allowable in the SIPO sufficiently correspond to the claims in the JPO application

【内容】

本出願の請求項 The claim in the JPO	中国国家知識産権局で特許可能とされた請求項 The patentable claim in the SIPO	対応関係に関するコメント Comments about the correspondence
1	1	両クレームは同一である。 Both claims are the same.
2	2	"
3	1	両クレームは、記載形式を除き同一である。 Both claims are the same except the claim format.
4	2	"
5	1	請求項5は、対応する SIPO 出願の請求項1にAという技術的特徴を付加したものである。 Claim 5 in the JPO adds feature A to Claim 1 in the SIPO

【物件名】 対応 SIPO 出願に対する**年**月**日付の第一次審査意見通知書の写し及びその翻訳文 1

Copy and translation of the First Notice of the Opinion on Examination in the SIPO on (date) 1

【内容】 Attach the copy of the document.

Use the same name as “【物件名】” under “【提出物件の目録】.”

【物件名】 対応 SIPO 出願に対する**年**月**日付の特許査定およびその翻訳文 1

Copy and translation of grant in the SIPO on (date) 1

【内容】 Attach the copy of the document.

【物件名】 対応中国出願で特許可能と判断された請求項の写し及びその翻訳文 1

Copy and translation of the claims indicated patentable in the report on the state of the art and written opinion in the SIPO on (date) 1

【内容】

Attach the copy of the document.

【物件名】 引用非特許文献1

Cited non-patent literature1

【内容】

Attach the copy of the document.

Part II

PPH using the PCT international work products from the SIPO

Applicants can request accelerated examination by a prescribed procedure including submission of relevant documents on an application which is filed with the JPO and satisfies the following requirements under the JPO-SIPO Patent Prosecution Highway pilot program based on PCT international work products (PCT-PPH pilot program).

When filing a request for the PCT-PPH pilot program, an applicant must submit a request form “The Explanation of Circumstances Concerning Accelerated Examination” based on the procedure prescribed in “the Guidelines of the Accelerated Examination and Appeal”¹. Under the PCT-PPH pilot program, an applicant is not required to fill in the section “2. the disclosure of prior arts and comparison between the claimed invention and prior art” in “The Explanation of Circumstances Concerning Accelerated Examination”.

1. Requirements

The application which is filed with the JPO and on which the applicant files a request under the PCT-PPH must satisfy the following requirements:

- (1) The latest work product in the international phase of a PCT application corresponding to the application (“international work product”), namely the Written Opinion of International Search Authority (WO/ISA), the Written Opinion of International Preliminary Examination Authority (WO/IPEA) or the International Preliminary Examination Report (IPER), indicates at least one claim as patentable/allowable (from the aspect of novelty, inventive steps and industrial applicability).**

Note that the ISA and the IPEA which produced the WO/ISA, WO/IPEA and the IPER are limited to the SIPO, but, if priority is claimed, the priority claim can be to an application in any Office, see example A' in Annex II (application ZZ can be any national application).

The applicant cannot file a request under PCT-PPH on the basis of an International Search Report (ISR) only.

In case any observation is described in Box VIII of WO/ISA, WO/IPEA or IPER which forms the basis of a PCT-PPH request, the applicant must explain why the claim(s) is/are not subject to the observation irrespective of whether or not an amendment is submitted to correct the observation noted in Box VIII. The application will not be eligible for participating in PCT-PPH pilot program if the applicant does not explain why the claim(s) is/are not subject to the observation. In this regard, however, it does not affect the decision on the eligibility of the application whether the explanation is adequate and/or whether the amendment submitted

¹ http://www.jpo.go.jp/torikumi/t_torikumi/souki/pdf/v3souki/guideline.pdf

overcomes the observation noted in Box VIII.

- (2) The relationship between the application and the corresponding international application satisfies one of the following requirements:**
- (A) The application is a national phase application of the corresponding international application. (See Figures A, A', and A'' in Annex II)**
 - (B) The application is a national application as a basis of the priority claim of the corresponding international application. (See Figure B in Annex II)**
 - (C) The application is a national phase application of an international application claiming priority from the corresponding international application. (See Figure C in Annex II)**
 - (D) The application is a national application claiming foreign/domestic priority from the corresponding international application. (See Figure D in Annex II)**
 - (E) The application is the derivative application (divisional application and application claiming domestic priority etc.) of the application which satisfies one of the above requirements (A) – (D). (See Figures E1 and E2 in Annex II)**
- (3) All claims on file, as originally filed or as amended, for examination under the PCT-PPH must sufficiently correspond to one or more of those claims indicated to be patentable/allowable in the latest international work product of the corresponding international application.**

Claims are considered to "sufficiently correspond" where, accounting for differences due to translations and claim format, the claims of the application are of the same or similar scope as the claims indicated to be patentable/allowable in the latest international work product, or the claims of the application are narrower in scope than the claims indicated to be patentable/allowable in the latest international work product.

In this regard, a claim that is narrower in scope occurs when a claim indicated to be patentable/allowable in the latest international work product is amended to be further limited by an additional feature that is supported in the specification (description and/or claims) of the application.

A claim of the application which introduces a new/different category of claims to those claims indicated to be patentable/allowable in the latest international work product is not considered to sufficiently correspond. For example, the claims indicated to be patentable/allowable in the latest international work product only contain claims to a process of manufacturing a product, then the claims of the application are not considered to sufficiently correspond if the claims of the application introduce product claims that are dependent on the corresponding process claims.

It is not necessary to include "all" claims determined to be patentable/allowable in the

corresponding international application in an application in the JPO (the deletion of claims is allowable). For example, in the case where the corresponding international application contains 5 claims determined to be patentable/allowable, the application in the JPO may contain only 3 of these 5 claims.

Any claims amended or added after the grant of the request for participation in the PCT-PPH pilot program need not to sufficiently correspond to the claims indicated as patentable/allowable in the latest international work product.

(4) The JPO has not begun examination of the application at the time of request under PCT-PPH.

2. Documents to be submitted

The applicant must submit the following documents attached to the request form in filing a request under PCT-PPH. Some of the documents may not be required to submit in certain cases.

(1) A copy of the latest international work product which indicated the claims to be patentable/allowable and their Japanese or English translations if they are not in English.

In case the application satisfies the relationship 1.(2)(A), the applicant need not submit a copy of the International Preliminary Report on Patentability (IPRP) and any English translations thereof because a copy of these documents is already contained in the file-wrapper of the application. In addition, if the copy of the latest international work product and the copy of the translation are available via “PATENTSCOPE (registered trademark)”², an applicant need not submit these documents, unless otherwise requested by the JPO.

(WO/ISA and IPER are usually available as “IPRP Chapter I” and “IPRP Chapter II” respectively in 30 months after the priority date.)

Machine translation will be admissible, but if it is impossible for the examiner to understand the outline of the latest translated international work product due to insufficient translation, the examiner can request the applicant to resubmit translations.

(2) A copy of a set of claims which the latest international work product of the corresponding international application indicated to be patentable/allowable and their Japanese or English translations if they are not in English

If the copy of the set of claims which are indicated to be patentable/allowable is available via “PATENTSCOPE (registered trademark)” (e.g. the international Patent Gazette has been

² <http://www.wipo.int/pctdb/en/index.jsp>

published), an applicant need not submit this document unless otherwise requested by the JPO. Where the set of claims is written in Chinese, the translations thereof must be still submitted by the applicant. Machine translations will be admissible, but if it is impossible for the examiner to understand the outline of the translated claims due to insufficient translation, the examiner can request the applicant to resubmit translations.

(3) A copy of references cited in the latest international work product of the international application corresponding to the application.

Documents which are only referred to as references and consequently do not consist of the reasons for refusal do not have to be submitted.

If the reference is a patent document, the applicant is not required to submit it. In case the JPO has difficulty in obtaining the document, however, the applicant may be asked to submit it. Non-patent literature must always be submitted. Translations of cited references are unnecessary.

(4) A claims correspondence table which indicates how all claims in the application sufficiently correspond to the claims indicated to be patentable/allowable.

When claims are just literal translation, the applicant can just write down that “they are the same” in the table. When claims are not just literal translation, it is necessary to explain the sufficient correspondence of each claim based on the criteria 1. (3) (Please refer to the Example form below).

When an applicant has already submitted the above mentioned documents (1) - (4) to the JPO through simultaneous or past procedures, the applicant may incorporate the documents by reference and is thus not required to attach the documents.

3. Example of “The Explanation of Circumstances Concerning Accelerated Examination” for filing request for an accelerated examination under the PCT-PPH pilot program

(1) Circumstances

The applicant must indicate that the application is included in (A) to (E) of 1. (2), and that the accelerated examination is requested under the PCT-PPH pilot program. The application number(s) of the corresponding international application(s) also must be written.

In case any observation is described in Box VIII of WO/ISA, WO/IPEA or IPER which forms the basis of a PCT-PPH request, the applicant must explain why the claim(s) is/are not subject to the observation.

(2) Documents to be submitted

The applicant must list all required documents mentioned above 2. in an identifiable way, even when applicant omits to submit certain documents.

(3) Notice

Please refer to the example of the form of “The Explanation of Circumstances Concerning Accelerated Examination” for both on-line and paper procedures³.

Note that in the case of paper procedure, the pendency period (the period between the request for PPH and the first office action) tends to be longer than on-line procedure.

4. Procedure for the accelerated examination under the PPH pilot program

The JPO decides whether the application can be entitled to the status for an accelerated examination under the PCT-PPH when it receives a request with the documents stated above. When the JPO decides that the request is acceptable, the application is assigned a special status for an accelerated examination under the PCT-PPH.

In those instances where the request does not meet all the requirements set forth above, the applicant will be notified and the defects in the request will be identified. Before the issue of the notification of not assigning a special status for accelerated examination under the PPH, the applicant will be given opportunity to submit missing documents. Even after the issue of the notification of not assigning a special status for accelerated examination under the PPH, the applicant can request the PPH again.

³ http://www.jpo.go.jp/torikumi/t_torikumi/souki/pdf/v3souki/guideline.pdf

**Example form of “The Explanation of Circumstances Concerning Accelerated Examination”
(Example of the request based on the claims indicated patentable/allowable in the IPER)**

<p>【書類名】 早期審査に関する事情説明書 The name of this paper</p>		<div style="border: 1px solid orange; padding: 5px; display: inline-block;">Bibliographical items</div>
<p>【提出日】 平成00年00月00日 Date of filing</p>		
<p>【あて先】 特許庁長官殿 Destination</p>		
<p>【事件の表示】 【出願番号】 特願 0000-000000 Application number</p>		
<p>【提出者】 【識別番号】 000000000 【住所又は居所】 〇〇県〇〇市〇丁目 【氏名又は名称】 〇〇〇〇 The name and address of who submit this</p>		
<p>【代理人】 【識別番号】 000000000 【住所又は居所】 〇〇県〇〇市〇丁目 【氏名又は名称】 〇〇 〇〇 The name and address of the attorney</p>		
<p>【早期審査に関する事情説明】 The explanation of circumstances concerning accelerated examination</p>		
<p>1. 事情 本出願は国際出願(出願番号 PCT/CN0000/000000)の国内移行出願であり、特許審査ハイウェイに基づく早期審査の申請を行うものである。 当該国際出願について国際予備審査機関としての中国国家知識産権局が作成した国際予備審査報告において、特許請求の範囲に対し特許可能との判断が明示されている。</p>		
<p>1. Circumstances This application is a national phase application of a PCT international application (the application number is PCT/CN0000/000000), and the accelerated examination is requested under the PPH program. The IPER issued by the SIPO as an IPEA indicates at least one claim to be allowable.</p>		
<p>(提出を省略する物件) (物件名)**年**月**日付の対応国際出願に対する IPER の写しおよびその翻訳文 (物件名)最新国際段階成果物で特許性有りと判断されたクレームの写し (物件名)対応国際出願に対して引用された米国特許第000000号公報 (物件名)対応国際出願に対して引用された日本国特許第000000号公報</p>		

List up the documents which can be omitted to submit

(Documents to be omitted to submit)
 (The name of the document) Copy and its translation of IPER on (date)
 (The name of the document) Copy of the claims indicated patentable in the latest international work product of the corresponding PCT international application WO 0000/000000
 (The name of the document) Cited reference of the corresponding PCT international application: United States Publication of application 0000000
 (The name of the document) Cited reference of the corresponding PCT international application: Japan Patent publication of application 0000000

以下において、「引用非特許文献1」とは、「村岡洋一著、「コンピュータサイエンス大学講座(第 11 巻) コンピュータ・アーキテクチャ」、第 2 版、株式会社近代科学者、1985 年 11 月、p. 123 - 127」である。

In what follows, “non-patent literature1” is “Yoichi Muraoka, Lecture of Computer Science (vol.11) computer architecture, 2nd edition, Scientist com, Nov. 1985, p.123-127.”

<In case of on-line procedure>

If the name of the document is long (over than 50 letters), it is impossible to write it down directly to the column “【物件名】.” Please write down the full name of the document in the column “【早期審査に関する事情説明】” and name it properly. Then write the name in the column “【物件名】.”

(第 VIII 欄に記載された意見についての釈明)

第 VIII 欄には、請求項7は明細書によって十分に裏付けされていないとの意見が記載されている。そこで、請求項7に XXX の技術的特徴を追加して限定する補正を行ったので、請求項7は明細書によって十分に裏付けられたと思料する。

(Explanation why the claim(s) is/are not subject to the observation noted in Box VIII)
 There is an observation noted in the Box VIII that claim 7 is not supported by the description. Claim 7 is amended to be further limited by an additional feature XXX. Therefore we assume that amended claim 7 is supported by the description.

【提出物件の目録】

The list of submitted documents

【物件名】 国際出願と本出願の請求項の対応関係を示す書面 1

The table to explain how the claims indicated as allowable in the international phase sufficiently correspond to the claims in the JP application 1

【物件名】 最新国際成果物で特許性有りと判断されたクレームの翻訳文 1

Translation of the claims indicated patentable in the latest international work product of the corresponding PCT international application 1

【物件名】 引用非特許文献1 1

Non-patent literature1 1

List up the documents to be submitted

<In case of on-line procedure> The applicants can describe the list of attached documents as below.
 <In case of paper procedure> The applicants have to describe the following not on this form but on accompanying sheets at each attached document.

Use the same name as “【物件名】” under “【提出物件の目録】.”

Attach the document here as image file or text.

【添付物件】

The list of attached documents

【物件名】 国際出願と本出願の請求項の対応関係を示す書面

The table to explain how the claims indicated as allowable in the international phase sufficiently correspond to the claims in the JPO application

【内容】

本出願の請求項	国際段階で特許可能とされた請求項	対応関係に関するコメント
The claim in the JPO	The allowable claim in the international phase	Comments about the correspondence
1	1	両クレームは同一である。 Both claims are the same.
2	2	”
3	1	両クレームは、記載形式を除き同一である。 Both claims are the same except the claim format.
4	2	”
5	1	請求項 5 は、国際段階の請求項 1 に A という技術的特徴を付加したものである。 Claim 5 in the JPO has additional feature A on the Claim 1 in the international phase.
6	5	両クレームは同一である。 Both claims are the same.
7	7	請求項 7 は、国際段階の請求項 7 に XXX という技術的特徴を付加したものである。 Claim 7 in the JPO has additional feature XXX on Claim 7 in the international phase.

【物件名】 最新国際成果物で特許性有りと判断されたクレームの翻訳文 1

Translation of the claims indicated patentable in the latest international work product of the corresponding PCT international application 1

【内容】 Attach the copy of the document.

【物件名】 引用非特許文献1

Non-patent literature1

【内容】 Attach the copy of the document.

Use the same name as “【物件名】” under “【提出物件の目録】.”

A A case meeting requirement (a) (i)
- Paris route -

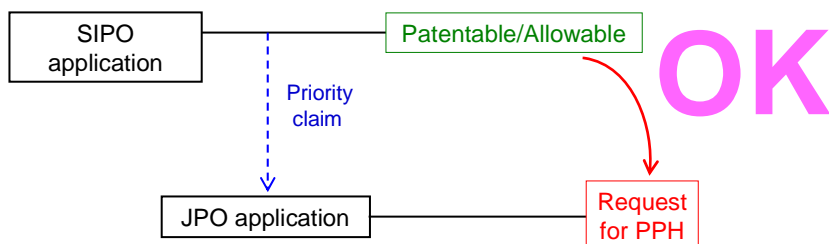

B A case meeting requirement (a) (i)
- PCT route -

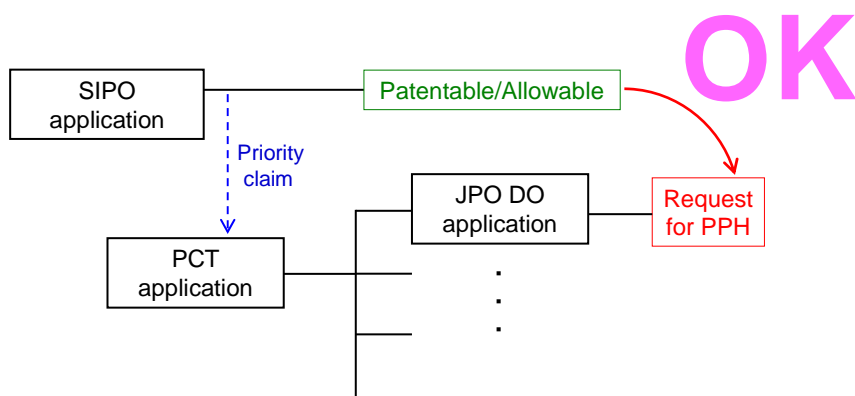

C

A case meeting requirement (a) (i)

- Paris route, Domestic priority -

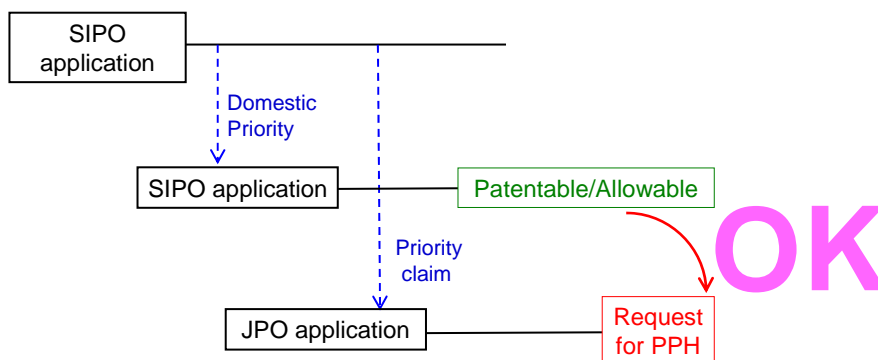

D

A case not meeting requirement (a)

- Paris route, but the first application is from the third country -

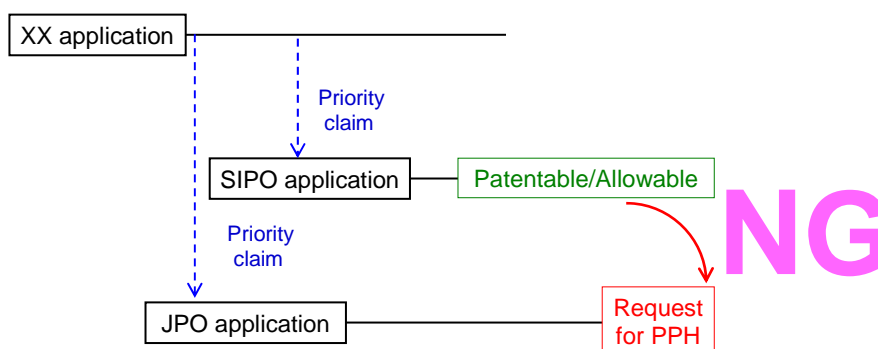

XX : the office other than the SIPO

E A case not meeting requirement (a)
- PCT route, but the first application is from the third country -

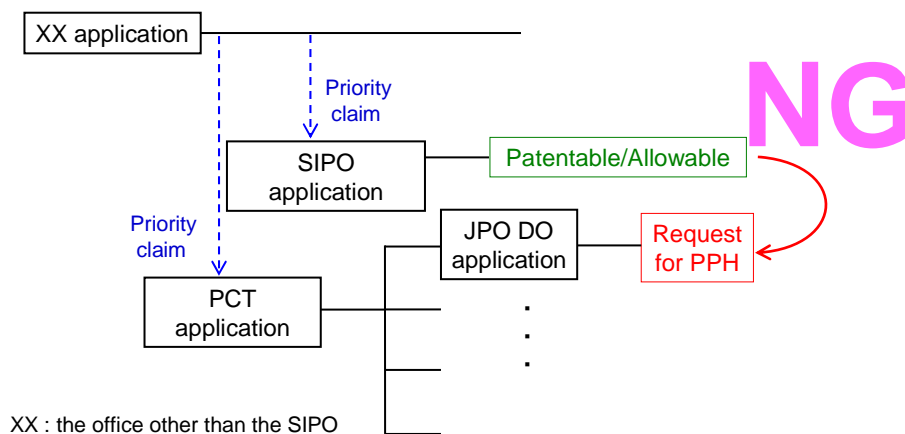

F A case meeting requirement (a) (i)
- Paris route & Complex priority -

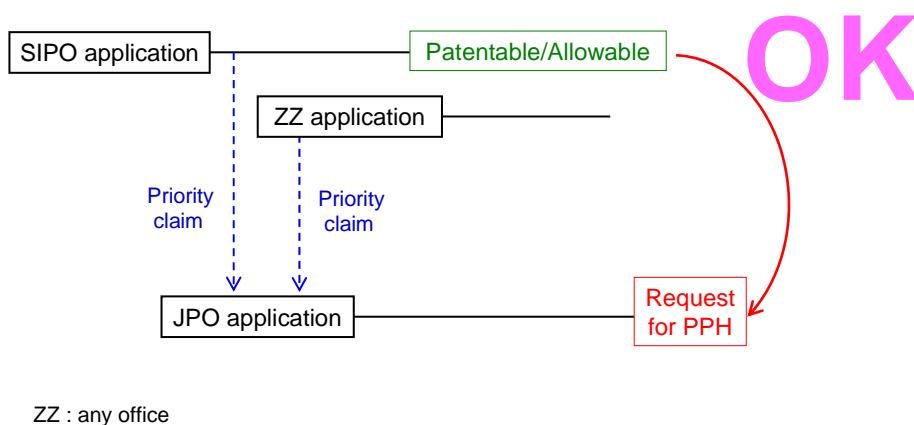

G A case meeting requirement (a) (i)
- Paris route & divisional application -

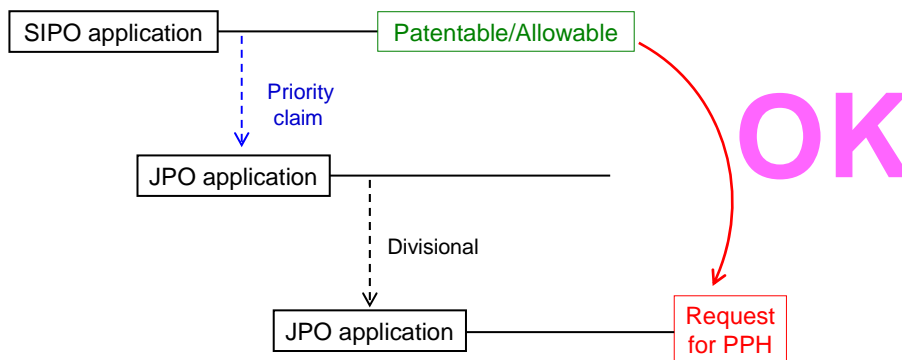

H A case meeting requirement (a) (i)
- PCT route -

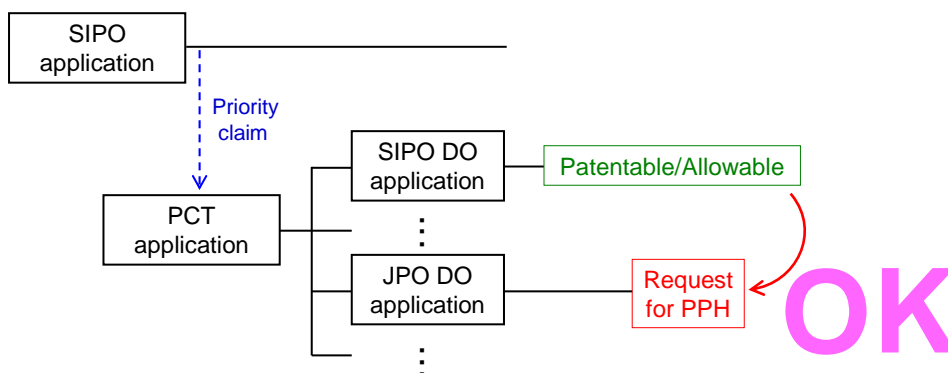

I A case meeting requirement (a) (ii)
- Direct PCT route -

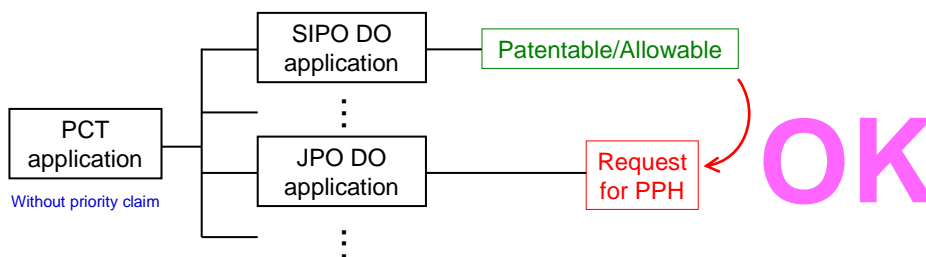

J A case meeting requirement (a) (iii)
- Direct PCT & Paris route -

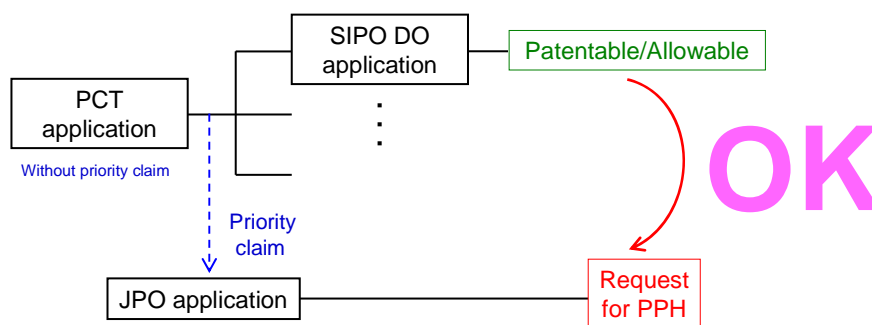

K A case meeting requirement (a) (ii)
- Direct PCT & PCT route -

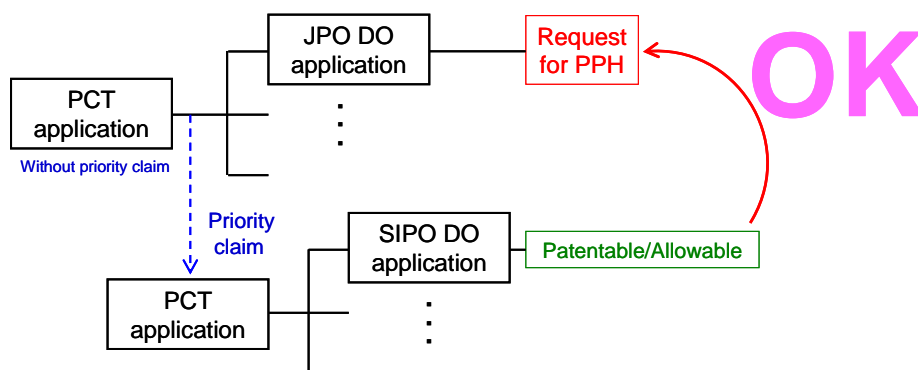

L A case meeting requirement (a) (iii)
- Direct PCT & PCT route -

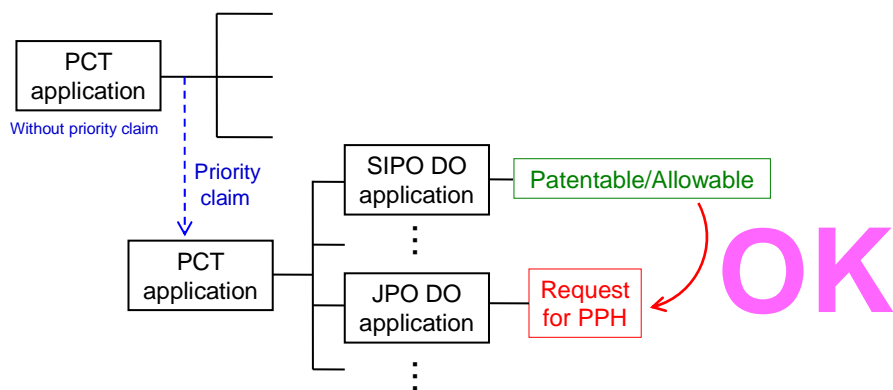

M A case not meeting requirement (d)
- Examination has begun before a request for PPH -

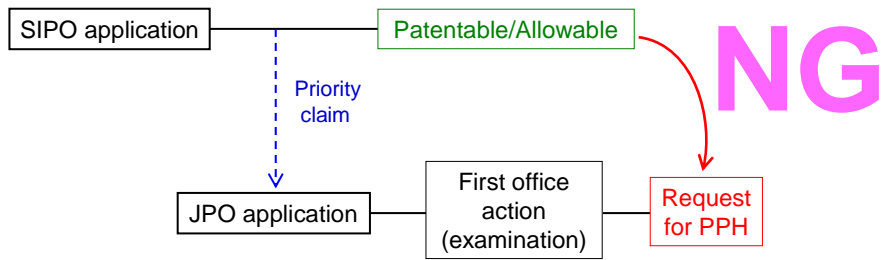

(A) The application is a national phase application of the corresponding international application.

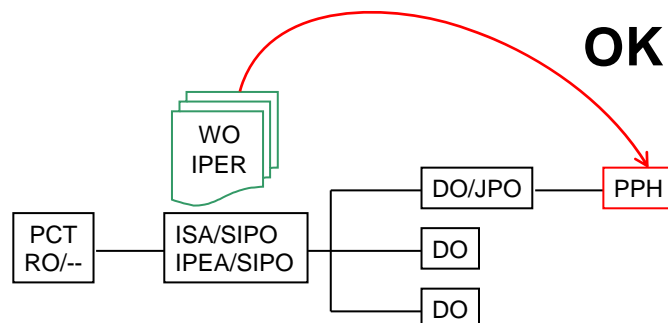

(A') The application is a national phase application of the corresponding international application.

(The corresponding international application claims priority from a national application.)

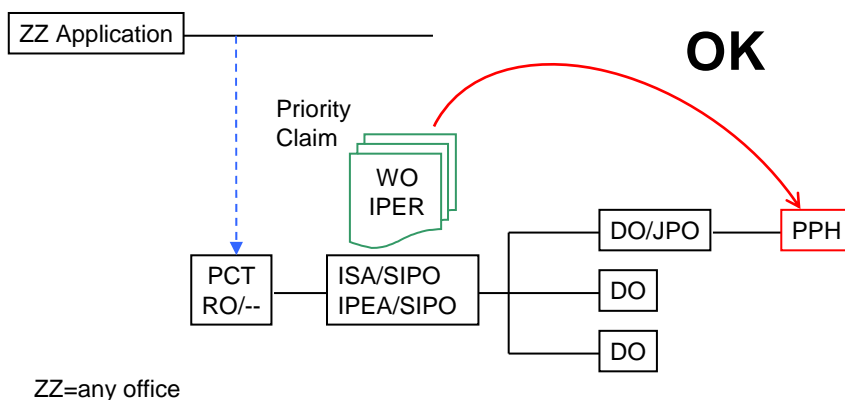

(A'') The application is a national phase application of the corresponding international application.

(The corresponding international application claims priority from an international application.)

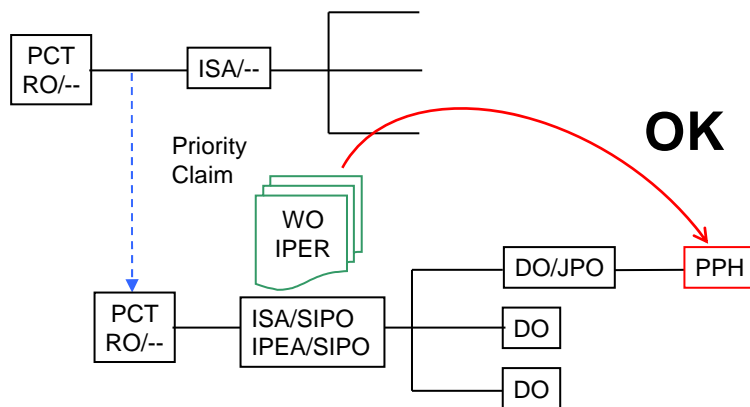

(B) The application is a national application as a basis of the priority claim of the corresponding international application.

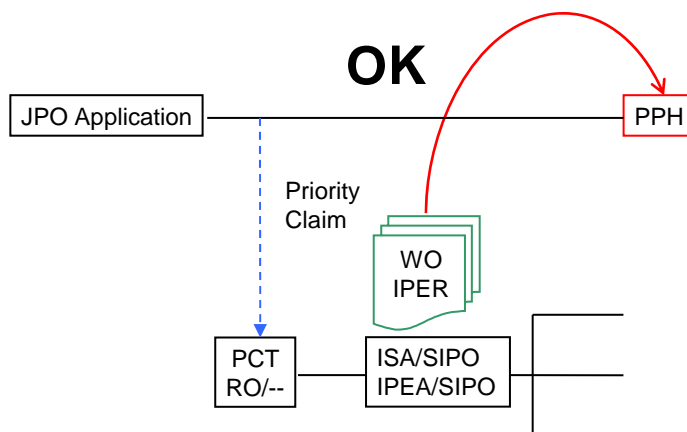

(C) The application is a national phase application of an international application claiming priority from the corresponding international application.

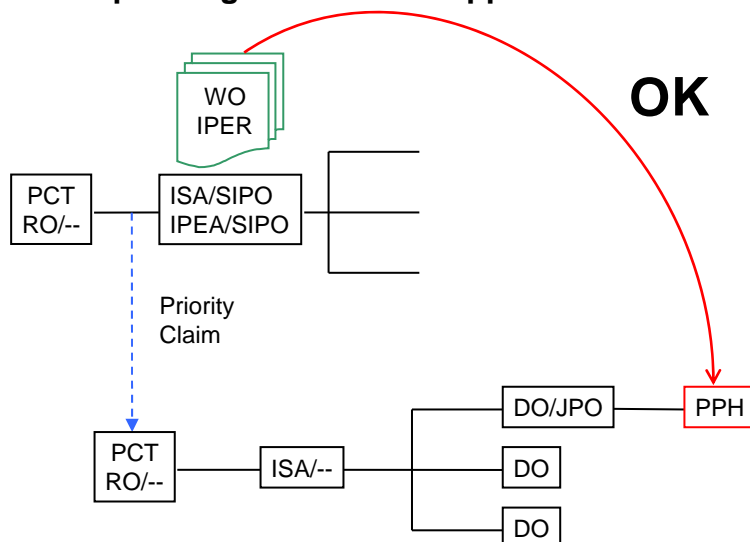

(D) The application is a national application claiming foreign/domestic priority from the corresponding international application.

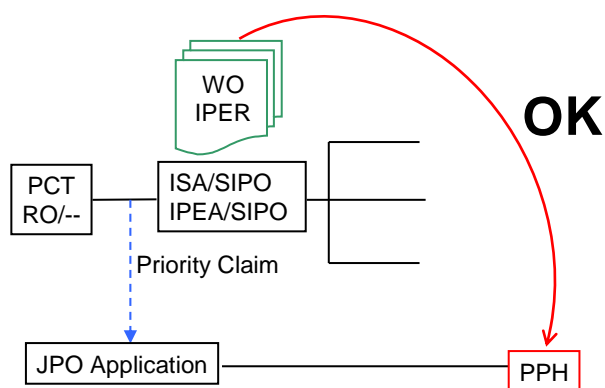

(E1) The application is a divisional application of an application which satisfies the requirement (A).

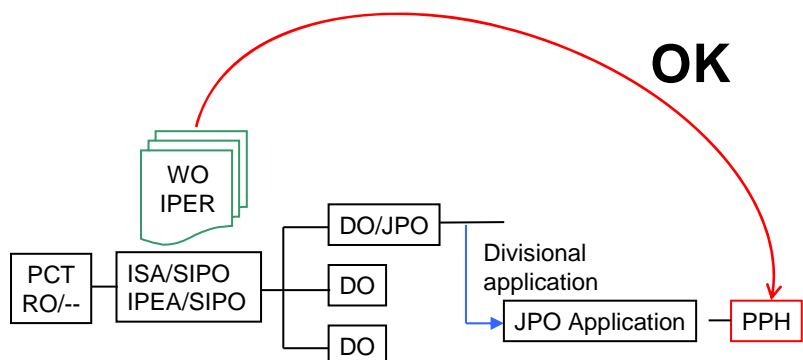

(E2) The application is an application claiming domestic priority from an application which satisfies the requirement (B).

