

Procedures to file a request to the JPO for Patent Prosecution Highway Pilot Program between the JPO and the DKPTO

1. Request to the JPO

When an applicant files a request for an accelerated examination under the Patent Prosecution Highway Pilot Program to the Japan Patent Office (JPO), an applicant must submit a request form “The Explanation of Circumstances Concerning Accelerated Examination” based on the procedure prescribed in “the Guidelines of the Accelerated Examination and Appeal”. (Please access to http://www.jpo.go.jp/torikumi/t_torikumi/souki/pdf/v3souki/guideline.pdf (Japanese only). “The Explanation of Circumstances Concerning Accelerated Examination” is described in P.31-33.)

Under the Patent Prosecution Highway Pilot Program, an applicant is not required to fill in section 2 (the disclosure of prior arts and comparison between the claimed invention and the prior art) in “The Explanation of Circumstances Concerning Accelerated Examination”, if the application, filed to the JPO, satisfies the following conditions (1) and the applicant attaches the following documents (2) to “The Explanation of Circumstances Concerning Accelerated Examination”.

(1) Requirements for requesting an accelerated examination under the PPH pilot program at the JPO

(a) *The JPO patent application (including PCT national phase application) is:*

- (i) an application which validly claims priority under the Paris Convention to the DKPTO application(s). Examples are provided in the annex to this guideline (hereafter “the Annex”) (figure A, B, H, I, J and K), or
- (ii) an PCT national phase application without priority claim. Examples are provided in the Annex (figure L), or
- (iii) an application which validly claims priority under the Paris Convention to the PCT application(s) without priority claim. Examples are provided in Annex (figure M, N and O).

A JPO application, which validly claims priority to multiple DKPTO or PCT applications, or which is a divisional application validly based on the originally filed application that is included in (i) to (iii) above, is also eligible.

(b) *At least one corresponding patent application exists in the DKPTO which has one or more claims that have been determined to be patentable by the DKPTO.*

Claims clearly identified to be patentable in the latest office action at the examination stage are able to be a base of a request for an accelerated examination under the PPH pilot

program, even if the application which includes those claims is not granted for patent yet. The following case will fall within this interpretation: When a DKPTO examiner sends a notification specifying the DKPTO's intention to grant. The headings for such notifications will be "Godkendelse".

(c) All claims on file, as originally filed or as amended, for examination under the PPH must sufficiently correspond to one or more of those claims indicated as allowable in the DKPTO.

Claims are considered to "sufficiently correspond" where, accounting for differences due to translations and claim format, the claims in the JPO are of the same or similar scope as the claims in the DKPTO, or the claims in the JPO are narrower in scope than the claims in the DKPTO.

In this regard, a claim that is narrower in scope occurs when a DKPTO claim is amended to be further limited by an additional feature that is supported in the specification (description and/or claims).

A claim in the JPO which introduces a new/different category of claims to those claims indicated as allowable in the DKPTO is not considered to sufficiently correspond. For example, where the DKPTO claims only contain claims to a process of manufacturing a product, then the claims in the JPO are not considered to sufficiently correspond if the JPO claims introduce product claims that are dependent on the corresponding process claims.

(d) The JPO has not begun examination of the patent application.

(2) Documents to be submitted

Documents (a) to (d) below must be submitted by attaching them to "The Explanation of Circumstances Concerning Accelerated Examination". It is noted that even when it is not needed to submit the documents mentioned below, the name of the documents must be listed in "The Explanation of Circumstances Concerning Accelerated Examination" (Please refer to the Example Form below for a more detailed guidance).

(a) Copies of all office actions¹ from the DKPTO, which were sent in regard to the corresponding patent application filed to the DKPTO, and translations of these office actions².

Both Japanese and English are acceptable as translation languages. An applicant who requests an accelerated examination under the PPH pilot program to the JPO does not

¹ Office actions are documents which relate to substantive patent examination.

² Machine translations are admissible, but if it is impossible for the examiner to understand the outline of the translated office action(s) or the patent claim(s), due to insufficient translation, the JPO examiner can request the applicant to resubmit translations.

have to submit copies of the office actions when those documents are provided via PVS online

(<http://onlineweb.dkpto.dk/pvsonline/patent?action=1&subAction=front&language=GB>). However, the translations of these office actions must be submitted by the applicant, because such translations are not provided via PVS online.

(b) *Copies of all claims determined to be patentable by the DKPTO, and translations of them².* Both Japanese and English are acceptable as translation languages. The descriptions above in requirement (2)(a) - regarding the occasions where the applicant is not required to submit copies and translations and regarding machine translations - also applies to this requirement (2)(b).

(c) *Copies of references cited by the DKPTO examiner*

If the references are patent documents, the applicant is not required to submit them, because the JPO will usually possess them. If the JPO does not possess such a patent document, the applicant must submit the patent document at the JPO examiner's request. Non-patent literature must always be submitted. It is unnecessary to provide translations of the references.

(d) *Claim correspondence table*

Applicants must submit a claim correspondence table which indicates how all claims in the JP application sufficiently correspond to the allowable/patentable claims in the DKPTO application.

When claims are just literal translation, the applicant can just write down that "they are same" in the table. When claims are not just literal translation, it is necessary to explain the sufficient correspondence of each claim based on the criteria (1) (c). Please refer to the Example Form below.

When an applicant has already submitted the above mentioned documents (a) to (d) to the JPO, through simultaneous or past procedures, the applicant may incorporate the documents by reference and is thus not required to attach the documents.

If the application does not fulfill the requirements (1) and (2) above, the applicant cannot omit to fill in section 2 (the disclosure of prior arts and comparison between the claimed invention and prior art) and the request for accelerated examination will not be accepted. In that case, the JPO will notify the applicant (or the representative) hereof including the reasons why accelerated examination is denied.

2. Guideline for filling out the application form “The Explanation of Circumstances Concerning Accelerated Examination” when requesting accelerated examination at the JPO under the PPH pilot program

(1) Circumstances

The applicant must indicate that the application falls within the eligible applications as defined in (i) to (iii) of requirement (1) (a) above and that accelerated examination is requested under the PPH pilot program. In addition, the applicant must also write the application number, the publication number or the patent number of the corresponding DKPTO application(s).

If the application (which has one or more claims that have been determined to be patentable by the DKPTO) is different from the application that fulfills the requirements laid down in (i) to (iii) of (1) (a) (for example, a divisional application of the basic application), the applicant must also write the application number, the publication number, or the patent number of the application(s) which has claims that have been determined to be patentable by the DKPTO. The applicant must also specify in writing the relationship between those applications.

(2) Documents to be submitted

The applicant must list all required documents mentioned above in requirement 1(2) (a) to (d) in an identifiable way, even when the applicant are allowed to omit the submission of certain documents according to these requirements 1(2) (a) to (d).

(3) Notice

The forms for “The Explanation of Circumstances Concerning Accelerated Examination” are different depending on if the applicant makes use of the on-line filing procedure or of the paper filing procedure. Please refer to the available application forms: “Form 1 for Accelerated Examination” for on-line procedures and “Form 2 for Accelerated Examination” for paper procedures. (Please access to http://www.jpo.go.jp/torikumi/t_torikumi/souki/pdf/v3souki/guideline.pdf (Japanese only). “Form 1 for Accelerated Examination” is described in P. 31 and “Form 2 for Accelerated Examination” is described in P. 32 .).

Example Form for the on-line PPH filing procedure

【書類名】 早期審査に関する事情説明書

The name of this paper

【提出日】 平成00年00月00日

Date of filing

【あて先】 特許庁長官殿

Destination

【事件の表示】

【出願番号】 特願 0000-000000

Application number

【提出者】

【識別番号】 000000000

【住所又は居所】 〇〇県〇〇市〇丁目

【氏名又は名称】 〇〇〇〇〇

The name and address of the submitter

【代理人】

【識別番号】 000000000

【住所又は居所】 〇〇県〇〇市〇丁目

【氏名又は名称】 〇〇 〇〇

The name and address of the attorney

Bibliographical items

【早期審査に関する事情説明】

The explanation of circumstances concerning accelerated examination

1. 事情

本出願はデンマーク特許商標庁への出願(特許出願番号0000000)をパリ条約に基づく優先権の基礎出願とする出願であり、特許審査ハイウェイ試行プログラムに基づく早期審査の申請を行うものである。

1. Circumstances

This application validly claims priority under the Paris Convention to the corresponding DKPTO application (the application number is 0000000) and the accelerated examination is requested under the PPH pilot program.

以下において、「引用非特許文献1」とは、「村岡洋一著、「コンピュータサイエンス大学講座(第11巻) コンピュータ・アーキテクチャ」、第2版、株式会社近代科学者、1985年11月、p.123-127」である。

In what follows, “non-patent literature1” is “Yoichi Muraoka, Lecture of Computer Science (vol.11) computer architecture, 2nd edition, Scientist com, Nov. 1985, p.123-127.”

If the name of the document is long (over 50 letters), it is impossible to write it down directly to the column “【物件名】”. In this case, please write down the full name of the document in the column “【早期審査に関する事情説明】” and name it properly. Then write the name in the column “【物件名】”.

【提出物件の目録】

The list of submitted documents

List up the documents to be submitted

- 【物件名】 デンマーク出願と本出願の請求項の対応関係を示す書面 1
- 【物件名】 **年**月**日付の対応デンマーク出願に対する調査報告書の写し 1
- 【物件名】 **年**月**日付の対応デンマーク出願に対する拒絶理由通知書の写し 1
- 【物件名】 **年**月**日付の対応デンマーク出願に対する特許査定書の写し 1
- 【物件名】 対応デンマーク出願の特許公報であるデンマーク公告第00000号公報 1
- 【物件名】 対応デンマーク出願に対して引用されたドイツ出願公開00000号公報 1
- 【物件名】 対応デンマーク出願に対して引用された日本国特許第00000号公報 1
- 【物件名】 引用非特許文献1 1

(The name of the document) The table explaining how the claims indicated as allowable by the DKPTO sufficiently correspond to the claims in the JPO application 1

(The name of the document) Copy of the search report from the DKPTO of (date) 1

(The name of the document) Copy of the examination report from the DKPTO of (date) 1

(The name of the document) Copy of the notification of grant by the DKPTO of (date) 1

(The name of the document) The publication of the corresponding application: Danish Patent number 0000000 1

(The name of the document) Cited reference of the corresponding DKPTO application: German Publication of application 0000000 1

(The name of the document) Cited reference of the corresponding DKPTO application: Japan Patent publication of application 0000000 1

(The name of the document) Cited non patent literature 1

Use the same name as in“【物件名】” under “【提出物件の目録】.”

Attach the document here as image file or text.

【添付物件】

The list of attached documents

- 【物件名】 デンマーク出願と本出願の請求項の対応関係を示す書面

The table explaining how the claims indicated as allowable by the DKPTO sufficiently correspond to the claims in the JPO application

【内容】

<p>本出願の請求項</p> <p>The claim filed to the JPO</p>	<p>デンマークで特許可能とされた請求</p> <p>The claim which the DKPTO found patentable</p>	<p>対応関係に関するコメント</p> <p>Comments about the correspondence</p>
<p>1</p>	<p>1</p>	<p>両クレームは同一である。</p> <p>Both claims are the same.</p>
<p>2</p>	<p>2</p>	<p>”</p>
<p>3</p>	<p>1</p>	<p>両クレームは、記載形式を除き同一である。</p> <p>Both claims are the same except the claim format.</p>
<p>4</p>	<p>2</p>	<p>”</p>
<p>5</p>	<p>1</p>	<p>請求項5は、デンマークの請求項1にAという構成を付加したものである。</p> <p>Claim 5 in the JPO application adds composition A to claim 1 filed at the DKPTO</p>

【物件名】 引用非特許文献1

Non-patent literature1

【内容】

Attach the copy of the document.

Use the same name as in “【物件名】” under “【提出物件の目録】.”

A

A case meeting requirement (a) (i)
- Paris route -

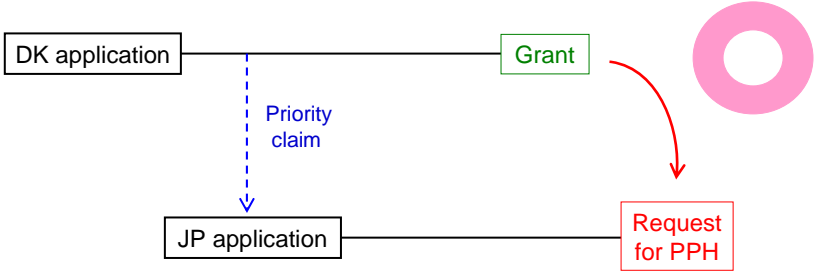

B

A case meeting requirement (a) (i)
- PCT route -

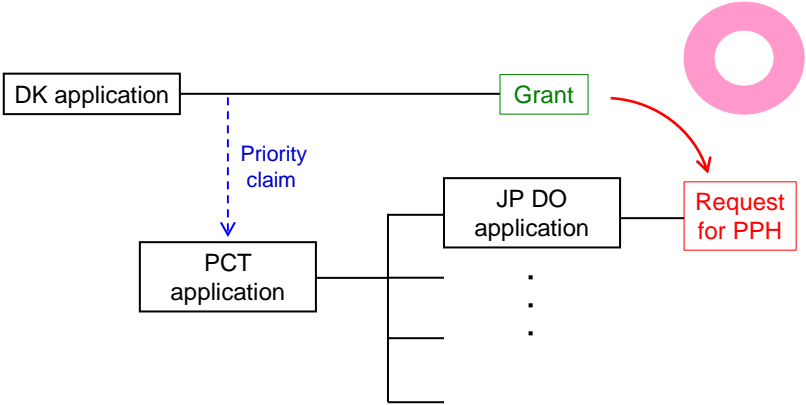

C

A case not meeting requirement (a)

- Paris route, but the first application is from the third country -

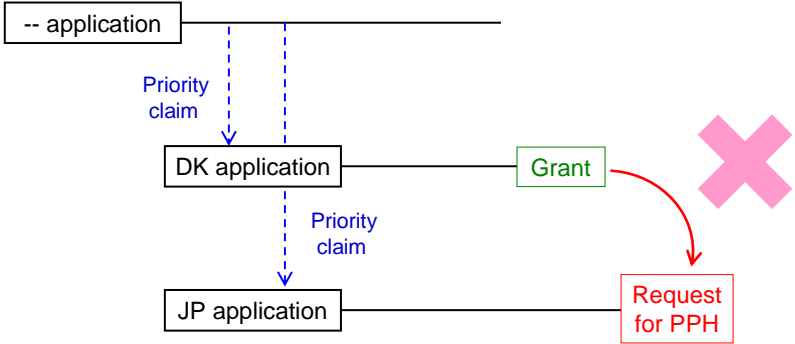

-- : NOT PPH participating country

D

A case not meeting requirement (a)

- PCT route, but the first application is from the third country -

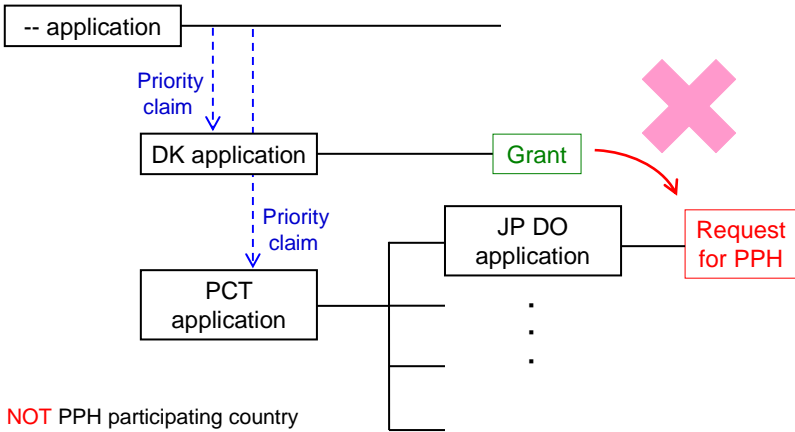

-- : NOT PPH participating country

E A case not meeting requirement (b)
- Search report -

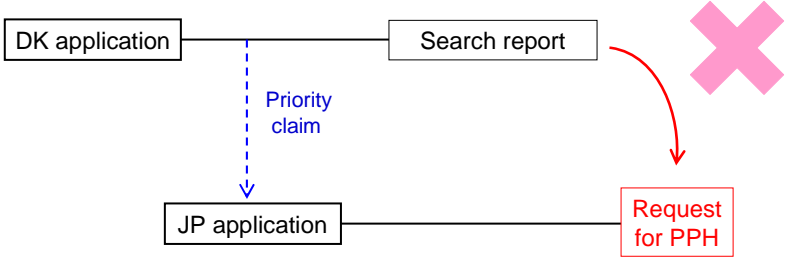

F A case not meeting requirement (b)
- ISR, ISO -

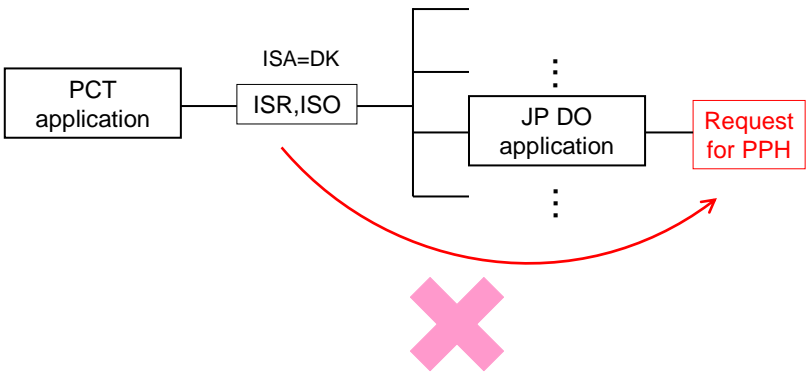

G A case not meeting requirement (d)
- Examination has begun before a request for PPH -

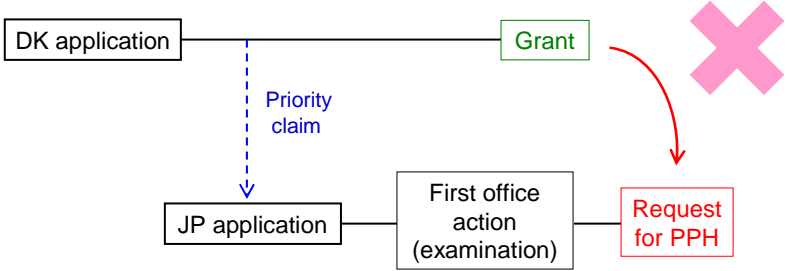

H A case meeting requirement (a) (i)
- Paris route & Complex priority -

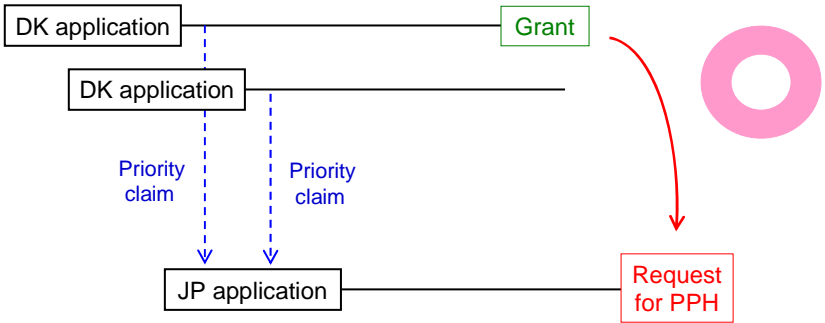

I

A case meeting requirement (a) (i)
- Paris route & Internal priority -

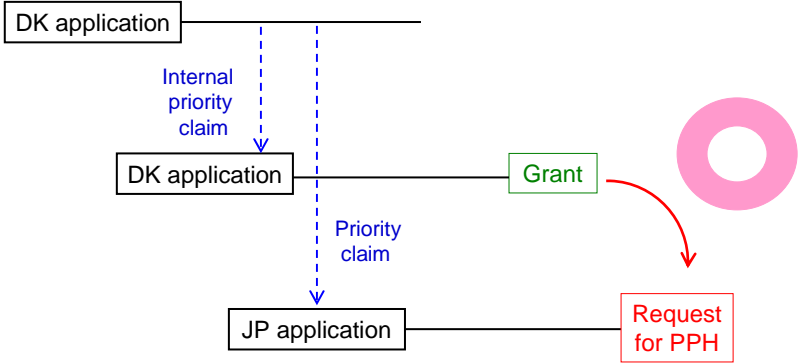

J

A case meeting requirement (a) (i)
- Paris route & divisional application -

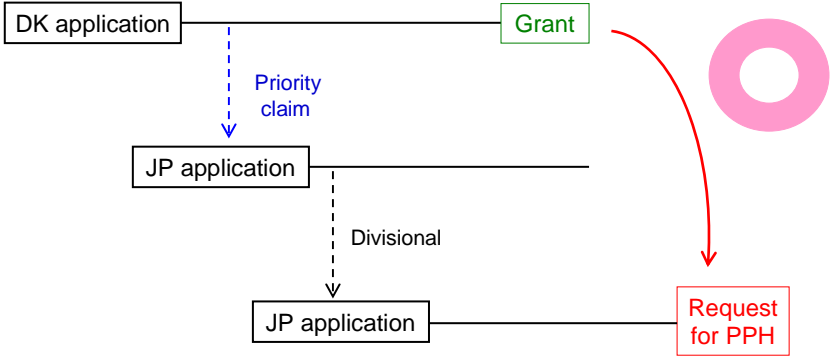

K

A case meeting requirement (a) (i)
- PCT route -

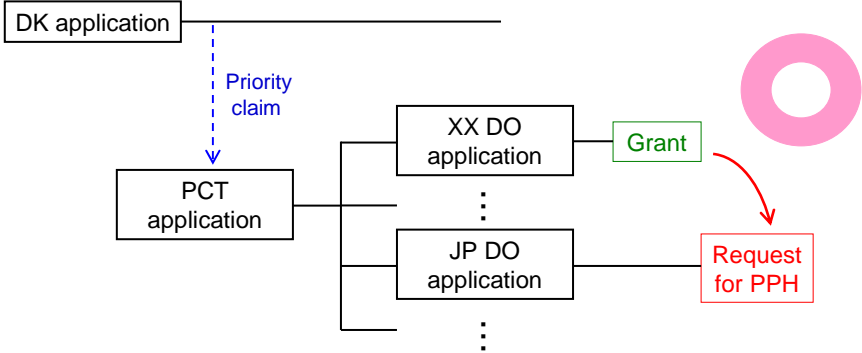

L

A case meeting requirement (a) (ii)
- Direct PCT route -

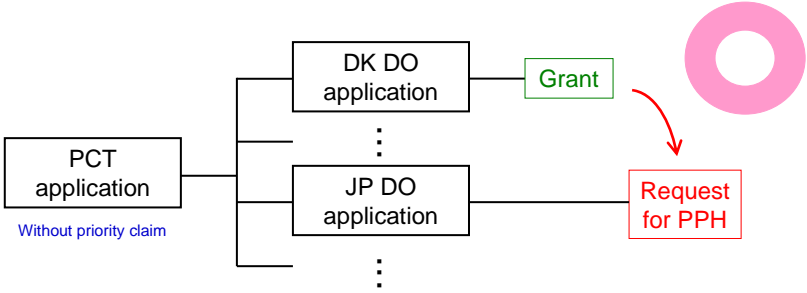

M A case meeting requirement (a) (iii)
- Direct PCT & Paris route -

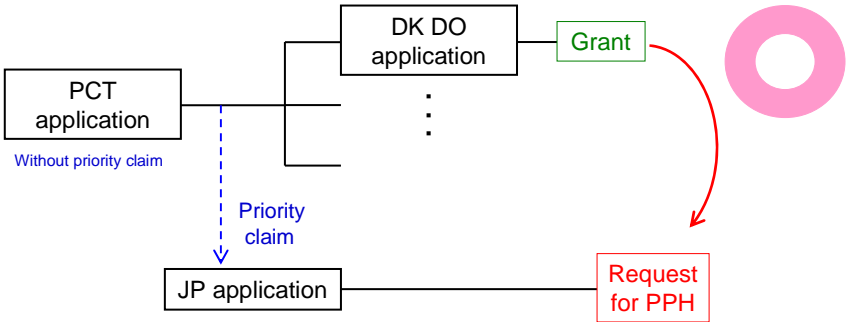

N A case meeting requirement (a) (iii)
- Direct PCT & PCT route -

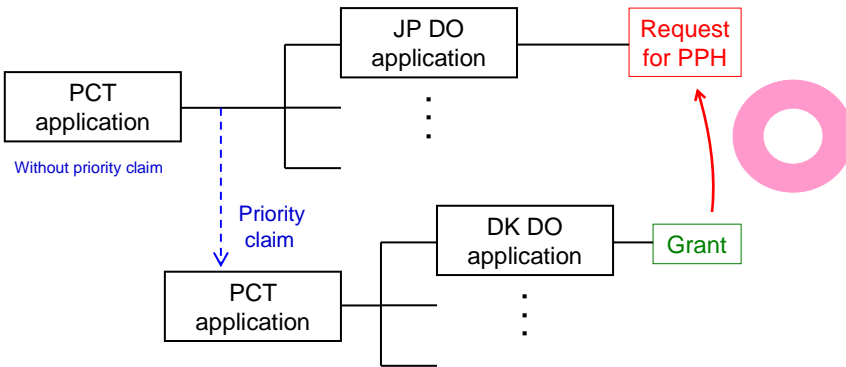

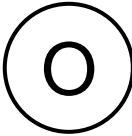

A case meeting requirement (a) (iii)
- Direct PCT & PCT route -

