

Procedures to file a request to the JPO for Patent Prosecution Highway Pilot Program between the JPO (Japan Patent Office) and the NBPR (National Board of Patent and Registration of Finland)

Part I

PPH using the national work products from the NBPR

Applicants can request accelerated examination by a prescribed procedure including submission of relevant documents on an application which is filed with the JPO and satisfies the following requirements under the JPO-NBPR Patent Prosecution Highway pilot program based on the NBPR application.

When filing a request for the PPH pilot program, an applicant must submit a request form "The Explanation of Circumstances Concerning Accelerated Examination" based on the procedure prescribed in "the Guidelines of the Accelerated Examination and Appeal."¹ Under the PPH pilot program, an applicant is not required to fill in the section "2. the disclosure of prior arts and comparison between the claimed invention and prior art" in "The Explanation of Circumstances Concerning Accelerated Examination".

1. Requirements

- (a) Both the JPO application on which PPH is requested and the NBPR application(s) forming the basis of the PPH request shall have the same earliest date (whether this be a priority date or a filing date).**

For example, the JPO application (including PCT national phase application) may be either: (Case I) an application which validly claims priority under the Paris Convention from the NBPR application(s) (examples are provided in ANNEX I, Figure A, B, C and D), or (Case II) an application which provides the basis of a valid priority claim under the Paris Convention for the NBPR application(s) (including PCT national phase application(s)) (examples are provided in ANNEX I, Figure E, F and G), or (Case III) an application which shares a common priority document with the NBPR application(s) (including PCT national phase application(s)) (examples are provided in ANNEX I, Figure H, I, J, K and L), or (Case IV) a PCT national phase application where both the JPO application and the NBPR application(s) are derived from a common PCT international application having no priority claim (an example is provided in ANNEX I, Figure M).

- (b) At least one corresponding application exists in the NBPR and has one or more claims that are determined to be patentable/allowable by the NBPR.**

¹ http://www.jpo.go.jp/torikumi/t_torikumi/souki/pdf/v3souki/guideline.pdf

Claims clearly identified to be patentable/allowable in the latest office action at examination stage are able to be a base of a request for an accelerated examination under the PPH pilot program, even if the application, which includes those claims is not granted for patent yet. The following case will fall within this interpretation: When an NBPR examiner sends a notification specifying the NBPR's intention to grant. The headings for such notifications will be "Communication of Approval" (The heading of the communication is "Hyväksyvä välipäätös").

(c) All claims on file, as originally filed or as amended, for examination under the PPH must sufficiently correspond to one or more of those claims indicated as allowable in the NBPR.

Claims are considered to "sufficiently correspond" where, accounting for differences due to translations and claim format, the claims in the JPO are of the same or similar scope as the claims in the NBPR, or the claims in the JPO are narrower in scope than the claims in the NBPR.

In this regard, a claim that is narrower in scope occurs when a NBPR claim is amended to be further limited by an additional feature that is supported in the specification (description and/or claims).

A claim in the JPO which introduces a new/different category of claims to those claims indicated as allowable in the NBPR is not considered to sufficiently correspond. For example, where the NBPR claims only contain claims to a process of manufacturing a product, then the claims in the JPO are not considered to sufficiently correspond if the JPO claims introduce product claims that are dependent on the corresponding process claims. Any claims amended or added after the grant of the request for participation in the PPH pilot program need not to sufficiently correspond to the claims indicated as allowable in the NBPR application.

(d) The JPO has not begun examination of the application (an example is provided in ANNEX I, Figure N).

2. Documents to be submitted

Documents (a) to (d) below must be submitted by attaching to "The Explanation of Circumstances Concerning Accelerated Examination".

Note that even when it is not needed to submit documents below, the name of the documents must be listed in "The Explanation of Circumstances Concerning Accelerated Examination" (Please refer to the Example form for the detail).

- (a) **Copies of all office actions¹ in the NBPR, which were sent for the corresponding application by the NBPR, and translations of them².**

Both Japanese and English are acceptable as translation language.³

- (b) **Copies of all claims determined to be patentable/allowable by the NBPR, and translations of them.**

Both Japanese and English are acceptable as translation language⁴.

- (c) **Copies of references cited by NBPR examiner**

If the references are patent documents, the applicant doesn't have to submit them because the JPO usually possess them. When the JPO does not possess the patent document, the applicant has to submit the patent document at the examiner's request. Non-patent literature must always be submitted.

The translations of the references are unnecessary.

- (d) **Claim correspondence table**

Applicant must submit a claim correspondence table, which indicates how all claims in the JPO application sufficiently correspond to the patentable/allowable claims in the NBPR application.

When claims are just literal translation, the applicant can just write down that "they are same" in the table. When claims are not just literal translation, it is necessary to explain the sufficient correspondence of each claim based on the criteria 1.(c) (Please refer to the **Example form**).

When the applicant has already submitted above documents 2.(a) to 2.(d) to the JPO through simultaneous or past procedures, the applicant may incorporate the documents by reference and does not have to attach them.

When the application doesn't fulfill the requirement of 1. and 2. above, the request of an accelerated examination is not accepted. In that case, the JPO will notify that and the reason for it to the applicant (or the representative).

¹ Office actions are documents which relate to substantive examination.

² Machine translations will be admissible, but if it is impossible for the examiner to understand the outline of the translated office action or claims due to insufficient translation, the examiner can request the applicant to resubmit translations.

³ When the copies and translations of all office actions are available for the JPO via NBPR's dossier access system, an applicant will not have to submit them to the JPO.

⁴ When the copies and translations of all patentable/allowable claims are available for the JPO via NBPR's dossier access system, an applicant will not have to submit them to the JPO.

3. Example of “The Explanation of Circumstances Concerning Accelerated Examination” for filing request an accelerated examination under the PPH pilot program

(1) Circumstances

Please indicate the relationship between the JPO application on which PPH is requested and the corresponding NBPR application(s) from the aspect of the above Requirement 1.(a), and state that an accelerated examination is requested under the PPH program. The application number(s) of the corresponding NBPR application(s) must be specified. If the application requested for the PPH or the corresponding NBPR application(s) is a derived application (e.g., the NBPR application that is indicated to be allowable/patentable is a divisional application of a NBPR application which forms the basis of the priority claim of the JPO application), please indicate the application number of its basic application.

(2) Documents to be submitted

The applicant must list all required documents mentioned above 2. in an identifiable way, even when applicant omits to submit certain documents.

(3) Notice

Forms of “The Explanation of Circumstances Concerning Accelerated Examination” are different between on-line procedure and paper procedure. Please refer to the examples of forms when filling in (“Form 1 for Accelerated Examination” for on-line procedures, and “Form 2 for Accelerated Examination” for paper procedures.).

Example form of on-line procedures

<p>【書類名】 早期審査に関する事情説明書 ----- The name of this paper</p>	<p>Bibliographical items</p>
<p>【提出日】 平成00年00月00日 ----- Date of filing</p>	
<p>【あて先】 特許庁長官殿 ----- Destination</p>	
<p>【事件の表示】 【出願番号】 特願 0000-000000 ----- Application number</p>	
<p>【提出者】 【識別番号】 000000000 【住所又は居所】 〇〇県〇〇市〇丁目 【氏名又は名称】 〇〇〇〇〇 ----- The name and address of who submit this</p>	
<p>【代理人】 【識別番号】 000000000 【住所又は居所】 〇〇県〇〇市〇丁目 【氏名又は名称】 〇〇 〇〇 ----- The name and address of the attorney</p>	
<p>【早期審査に関する事情説明】 ----- The explanation of circumstances concerning accelerated examination</p>	
<p>1. 事情 本出願とフィンランド特許登録庁への対応出願(特許出願番号0000000)は、共に、米国特許商標庁への一つの出願(出願番号00/000000)に対してパリ条約に基づく優先権を有効に主張する出願であり、特許審査ハイウェイ試行プログラムに基づく早期審査の申請を行うものである。</p>	
<p>1. Circumstances Both this application and the corresponding NBPR application (the application number is 0000000) validly claim priority under the Paris Convention to a USPTO application (the application number is 00/000000), and the accelerated examination is requested under the PPH program.</p>	
<p>以下において、「引用非特許文献1」とは、「村岡洋一著、「コンピュータサイエンス大学講座(第 11 巻) コンピュータ・アーキテクチャ」、第 2 版、株式会社近代科学者、1985 年 11 月、p. 123 - 127」である。</p>	
<p>In what follows, “non-patent literature1” is “Yoichi Muraoka, Lecture of Computer Science (vol.11) computer architecture, 2nd edition, Scientist com, Nov. 1985, p.123-127.”</p>	
<p>If the name of the document is long (over than 50 letters), it is impossible to write it down directly to the column “【物件名】.” Please write down the full name of the document in the column “【早期審査に関する事情説明】” and name it properly. Then write the name in the column “【物件名】.”</p>	

【提出物件の目録】

List up the documents to be submitted

The list of submitted documents

- 【物件名】 フィンランド出願と本出願の請求項の対応関係を示す書面 1
- 【物件名】 **年**月**日付の対応フィンランド出願に対する調査報告書の写し 1
- 【物件名】 **年**月**日付の対応フィンランド出願に対する拒絶理由通知書の写し 1
- 【物件名】 **年**月**日付の対応フィンランド出願に対する特許査定書の写し 1
- 【物件名】 対応フィンランド出願の特許公報であるフィンランド特許第00000号公報 1
- 【物件名】 対応フィンランド出願に対して引用されたドイツ出願公開00000号公報 1
- 【物件名】 対応フィンランド出願に対して引用された日本国特許第00000号公報 1
- 【物件名】 引用非特許文献 1

- (The name of the document) The table to explain how the claims indicated as allowable in the NBPR sufficiently correspond to the claims in the JPO application 1
- (The name of the document) Copy of search report in the NBPR on (date) 1
- (The name of the document) Copy of examination report in the NBPR on (date) 1
- (The name of the document) Copy of notification of grant in the NBPR on (date) 1
- (The name of the document) Corresponding NBPR application's patent publication: Patent number 0000000 1
- (The name of the document) Cited reference of the corresponding NBPR application: German Publication of application 0000000 1
- (The name of the document) Cited reference of the corresponding NBPR application: Japanese Patent publication of application 0000000 1
- (The name of the document) Cited non patent literature 1

Use the same name as “【物件名】” under “【提出物件の目録】.”

Attach the document here as image file or text.

【添付物件】

The list of attached documents

- 【物件名】 フィンランド出願と本出願の請求項の対応関係を示す書面

The table to explain how the claims indicated as allowable in the NBPR sufficiently correspond to the claims in the JPO application

【内容】

本出願の請求項	フィンランドで特許可能とされた請求項	対応関係に関するコメント
The claim in the JPO	The patentable claim in the NBPR	Comments about the correspondence
1	1	両クレームは同一である。 Both claims are the same.
2	2	”

Part I PPH using the national work products from the NBPR

3	1	両クレームは、記載形式を除き同一である。 Both claims are the same except the claim format.
4	2	”
5	1	請求項5は、フィンランドの請求項1にAという技術的特徴を付加したものである。 Claim 5 in the JPO adds feature A to Claim 1 in the NBPR

【物件名】 引用非特許文献1

Non-patent literature1

【内容】

Attach the copy of the document.

Use the same name as “【物件名】” under “【提出物件の目録】.”

Note that in the case of paper procedure, the pendency period (the period between the request for PPH and the first office action) tends to be longer than on-line procedure.

Part II

PPH using the PCT international work products from the NBPR

Applicants can request accelerated examination by a prescribed procedure including submission of relevant documents on an application which is filed with the JPO and satisfies the following requirements under the JPO-NBPR Patent Prosecution Highway pilot program based on PCT international work products (PCT-PPH pilot program).

When filing a request for the PCT-PPH pilot program, an applicant must submit a request form “The Explanation of Circumstances Concerning Accelerated Examination” based on the procedure prescribed in “the Guidelines of the Accelerated Examination and Appeal.”⁶ Under the PCT-PPH pilot program, an applicant is not required to fill in the section “2. the disclosure of prior arts and comparison between the claimed invention and prior art” in “The Explanation of Circumstances Concerning Accelerated Examination”.

The Offices may terminate the PCT-PPH pilot program early if the volume of participation exceeds manageable level, or for any other reason. Notice will be published if the PCT-PPH pilot program is terminated.

1. Requirements

The application which is filed with the JPO and on which the applicant files a request under the PCT-PPH must satisfy the following requirements:

- (1) The latest work product in the international phase of a PCT application corresponding to the application (“international work product”), namely the Written Opinion of International Search Authority (WO/ISA), the Written Opinion of International Preliminary Examination Authority (WO/IPEA) or the International Preliminary Examination Report (IPER), indicates at least one claim as patentable/allowable (from the aspect of novelty, inventive steps and industrial applicability).

Note that the ISA and the IPEA which produced the WO/ISA, WO/IPEA and the IPER are limited to the NBPR, but, if priority is claimed, the priority claim can be to an application in any Office, see example A' in Annex II (application ZZ can be any national application).

The applicant cannot file a request under PCT-PPH on the basis of an International Search Report (ISR) only.

In case any observation is described in Box VIII of WO/ISA, WO/IPEA or IPER which forms the basis of a PCT-PPH request, the applicant must explain why the claim(s) is/are not subject to the observation whether or not an amendment is submitted to correct the observation noted in Box VIII. The application will not be eligible for participating in PCT-PPH pilot program if the applicant does not explain why the claim(s) is/are not subject to the observation. In this regard,

⁶ http://www.jpo.go.jp/torikumi/t_torikumi/souki/pdf/v3souki/guideline.pdf

however, it does not affect the decision on the eligibility of the application whether the explanation is adequate and/or whether the amendment submitted overcomes the observation noted in Box VIII.

- (2) The relationship between the application and the corresponding international application satisfies one of the following requirements:
 - (A) The application is a national phase application of the corresponding international application. (See Diagrams A, A', and A'' in Annex II)
 - (B) The application is a national application as a basis of the priority claim of the corresponding international application. (See Diagram B in Annex II)
 - (C) The application is a national phase application of an international application claiming priority from the corresponding international application. (See Diagram C in Annex II)
 - (D) The application is a national application claiming foreign/domestic priority from the corresponding international application. (See Diagram D in Annex II)
 - (E) The application is the derivative application (divisional application and application claiming domestic priority etc.) of the application which satisfies one of the above requirements (A) – (D). (See Diagrams E1 and E2 in Annex II)

- (3) All claims on file, as originally filed or as amended, for examination under the PCT-PPH must sufficiently correspond to one or more of those claims indicated as allowable in the NBPR as ISA/IPEA.

Claims are considered to "sufficiently correspond" where, accounting for differences due to translations and claim format, the claims in the JPO are of the same or similar scope as the claims in the NBPR, or the claims in the JPO are narrower in scope than the claims in the NBPR.

In this regard, a claim that is narrower in scope occurs when an NBPR claim is amended to be further limited by an additional feature that is supported in the specification (description and/or claims).

A claim in the JPO which introduces a new/different category of claims to those claims indicated as allowable in the NBPR is not considered to sufficiently correspond. For example, the NBPR claims only contain claims to a process of manufacturing a product, then the claims in the JPO are not considered to sufficiently correspond if the JPO claims introduce product claims that are dependent on the corresponding process claims.

Any claims amended or added after the grant of the request for participation in the PCT-PPH pilot program need not to sufficiently correspond to the claims indicated as allowable in the latest international work product.

- (4) The JPO has not begun examination of the application at the time of request under PCT-PPH.

2. Documents to be submitted

The applicant must submit the following documents attached to the request form in filing a request under PCT-PPH.

Some of the documents may not be required to submit in certain cases. Please note that the name of the documents omitted to submit still have to be listed in “The Explanation of Circumstances Concerning Accelerated Examination” (Please refer to the Example form for the detail).

- (1) A copy of the latest international work product which indicated the claims to be patentable/allowable and their Japanese or English translations if they are not in English.

In case the application satisfies the relationship I.(2)(A), the applicant need not submit a copy of the International Preliminary Report on Patentability (IPRP) and any English translations thereof because a copy of these documents is already contained in the file-wrapper of the application. In addition, if the copy of the latest international work product and the copy of the translation are available via “PATENTSCOPE (registered trademark)”*, an applicant need not submit these documents, unless otherwise requested by the JPO.

(WO/ISA and IPER are usually available as “IPRP Chapter I” and “IPRP Chapter II” respectively in 30 months after the priority date.)

- (2) A copy of a set of claims which the latest international work product of the corresponding international application indicated to be patentable/allowable and their Japanese or English translations if they are not in English

If the copy of the set of claims which are indicated to be patentable/allowable is available via “PATENTSCOPE (registered trademark)” (e.g. the international Patent Gazette has been published), an applicant need not submit this document unless otherwise requested by the JPO.

- (3) A copy of references cited in the latest international work product of the international application corresponding to the application.

If the reference is a patent document, the applicant is not required to submit it. In case the JPO has difficulty in obtaining the document, however, the applicant may be asked to submit it. Non-patent literature must always be submitted. Translations of cited documents are unnecessary.

* <http://www.wipo.int/pctdb/en/index.jsp>

- (4) A claims correspondence table which indicates how all claims in the application sufficiently correspond to the claims indicated to be patentable/allowable.

When claims are just literal translation, the applicant can just write down that “they are the same” in the table. When claims are not just literal translation, it is necessary to explain the sufficient correspondence of each claim based on the criteria 1. (3) (Please refer to the **Example form** below).

When an applicant has already submitted the above mentioned documents (1) - (4) to the JPO through simultaneous or past procedures, the applicant may incorporate the documents by reference and is thus not required to attach the documents.

3. Example of “The Explanation of Circumstances Concerning Accelerated Examination” for filing request an accelerated examination under the PCT-PPH pilot program

(1) Circumstances

The applicant must indicate that the application is included in (A) to (E) of 1. (2), and that the accelerated examination is requested under the PCT-PPH pilot program. The application number(s) of the corresponding international application(s) also must be written.

In case any observation is described in Box VIII of WO/ISA, WO/IPEA or IPER which forms the basis of a PCT-PPH request, the applicant must explain why the claim(s) is/are not subject to the observation.

(2) Documents to be submitted

The applicant must list all required documents mentioned above 2. in an identifiable way, even when applicant omits to submit certain documents.

(3) Notice

Forms of “The Explanation of Circumstances Concerning Accelerated Examination” are different between on-line procedure and paper procedure. Please refer to the examples of forms when filling in (“Form 1 for Accelerated Examination” for on-line procedures, and “Form 2 for Accelerated Examination” for paper procedures.)⁷.

⁷ http://www.jpo.go.jp/torikumi/t_torikumi/souki/pdf/v3souki/guideline.pdf

Example form of on-line procedures

<p>【書類名】 早期審査に関する事情説明書 The name of this paper</p>	<div style="border: 1px solid orange; padding: 5px; display: inline-block;">Bibliographical items</div>
<p>【提出日】 平成00年00月00日 Date of filing</p>	
<p>【あて先】 特許庁長官殿 Destination</p>	
<p>【事件の表示】 【出願番号】 特願 0000-000000 Application number</p>	
<p>【提出者】 【識別番号】 000000000 【住所又は居所】 〇〇県〇〇市〇丁目 【氏名又は名称】 〇〇〇〇 The name and address of who submit this</p>	
<p>【代理人】 【識別番号】 000000000 【住所又は居所】 〇〇県〇〇市〇丁目 【氏名又は名称】 〇〇 〇〇 The name and address of the attorney</p>	
<p>【早期審査に関する事情説明】 The explanation of circumstances concerning accelerated examination</p>	
<p>1. 事情 本出願は国際出願(出願番号 PCT/FI0000/000000)の国内移行出願であり、特許審査ハイウェイに基づく早期審査の申請を行うものである。 当該国際出願について国際調査機関としてのフィンランド特許登録庁が作成した見解書において、特許請求の範囲に対し特許可能との判断が明示されている。</p>	
<p>1. Circumstances This application is a national phase application of a PCT international application (the application number is PCT/FI0000/000000), and the accelerated examination is requested under the PPH program. The WO/ISA issued by the NBPR as an ISA indicates at least one claim to be allowable.</p>	
<p>(提出を省略する物件) (物件名)**年**月**日付の対応国際出願に対する WO/ISA の写し (物件名)対応国際出願の国際公開公報である国際公開第0000/000000号 (物件名)対応国際出願に対して引用された米国特許第000000号公報 (物件名)対応国際出願に対して引用された日本国特許第000000号公報</p>	

List up the documents which can be omitted to submit

(Documents to be omitted to submit)
(The name of the document) Copy of WO/ISA on (date)
(The name of the document) International publication of the corresponding PCT international application: WO 0000/000000
(The name of the document) Cited reference of the corresponding PCT international application: United States Publication of application 0000000
(The name of the document) Cited reference of the corresponding PCT international application: Japan Patent publication of application 0000000

以下において、「引用非特許文献1」とは、「村岡洋一著、「コンピュータサイエンス大学講座(第 11 巻) コンピュータ・アーキテクチャ」、第 2 版、株式会社近代科学者、1985 年 11 月、p. 123 - 127」である。

In what follows, “non-patent literature1” is “Yoichi Muraoka, Lecture of Computer Science (vol.11) computer architecture, 2nd edition, Scientist com, Nov. 1985, p.123-127.”

If the name of the document is long (over than 50 letters), it is impossible to write it down directly to the column “【物件名】.” Please write down the full name of the document in the column “【早期審査に関する事情説明】” and name it properly. Then write the name in the column “【物件名】.”

(第 VIII 欄に記載された意見についての釈明)

第 VIII 欄には、請求項7は明細書によって十分に裏付けされていないとの意見が記載されている。そこで、請求項7に XXX の技術的特徴を追加して限定する補正を行ったので、請求項7は明細書によって十分に裏付けられたと思料する。

(Explanation why the claim(s) is/are not subject to the observation noted in Box VIII)
There is an observation noted in the Box VIII that claim 7 is not supported by the description. Claim 7 is amended to be further limited by an additional feature XXX. Therefore we assume that amended claim 7 is supported by the description.

【提出物件の目録】

The list of submitted documents

【物件名】 国際出願と本出願の請求項の対応関係を示す書面 1

The table to explain how the claims indicated as allowable in the international phase sufficiently correspond to the claims in the JP application 1

【物件名】 引用非特許文献1 1

Non-patent literature1 1

List up the documents to be submitted

Use the same name as “【物件名】” under “【提出物件の目録】.”

Attach the document here as image file or text.

【添付物件】

The list of attached documents

【物件名】 国際出願と本出願の請求項の対応関係を示す書面

The table to explain how the claims indicated as allowable in the international phase sufficiently correspond to the claims in the JPO application

【内容】

本出願の請求項 The claim in the JPO	国際段階で特許可能とされた請求項 The allowable claim in the international phase	対応関係に関するコメント Comments about the correspondence
1	1	両クレームは同一である。 Both claims are the same.
2	2	"
3	1	両クレームは、記載形式を除き同一である。 Both claims are the same except the claim format.
4	2	"
5	1	請求項 5 は、国際段階の請求項 1 に A という技術的特徴を付加したものである。 Claim 5 in the JPO has additional feature A on the Claim 1 in the international phase.
6	5	両クレームは同一である。 Both claims are the same.
7	7	請求項 7 は、国際段階の請求項 7 に XXX という技術的特徴を付加したものである。 Claim 7 in the JPO has additional feature XXX on Claim 1 in the international phase.

【物件名】 引用非特許文献1

Non-patent literature1

【内容】

Use the same name as “【物件名】” under “【提出物件の目録】.”

Attach the copy of the document.

Note that in the case of paper procedure, the pendency period (the period between the request for PPH and the first office action) tends to be longer than on-line procedure.

A

(Case I)
- Paris route -

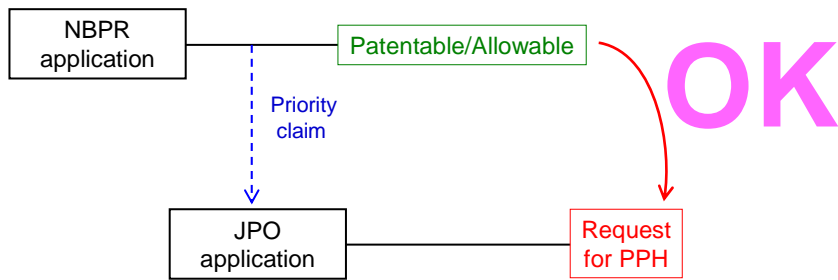

B

(Case I)
- PCT route -

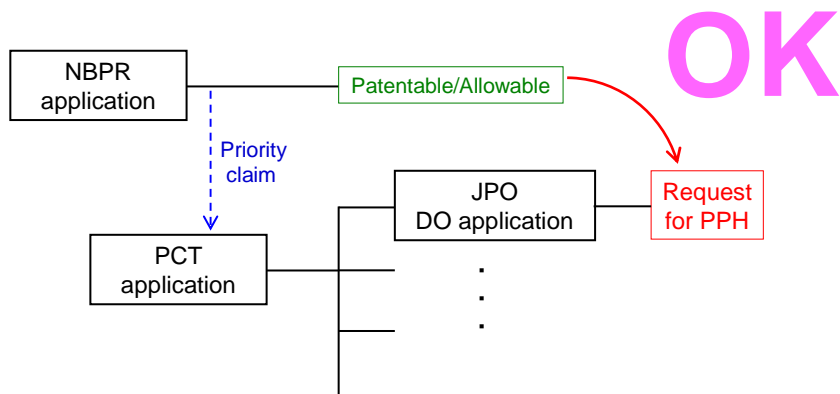

C

(Case I)
- Paris route & Complex priority -

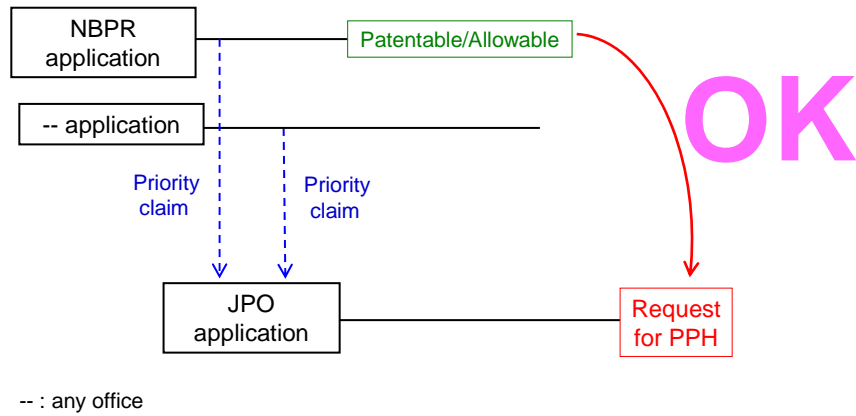

D

(Case I)
- Paris route & divisional application -

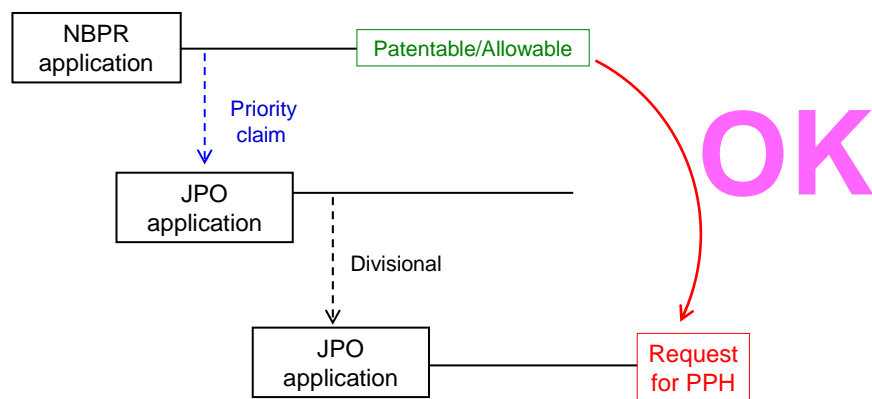

E

(Case II)
- Paris route -

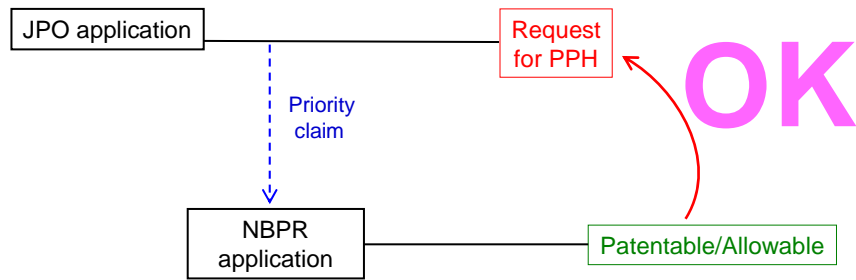

F

(Case II)
- PCT route -

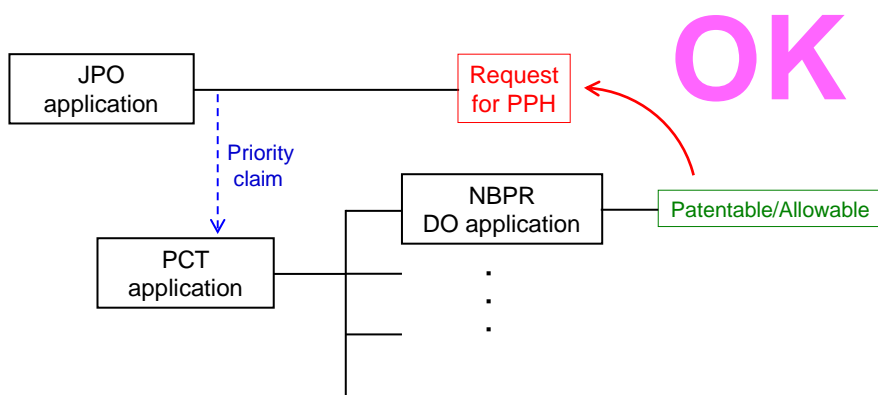

G

(Case II)

- Paris route & Complex priority -

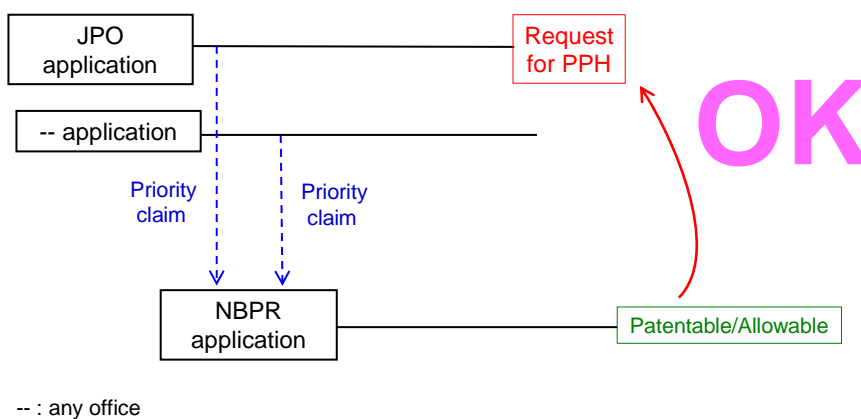

H

(Case III)

- Paris route, Internal priority -

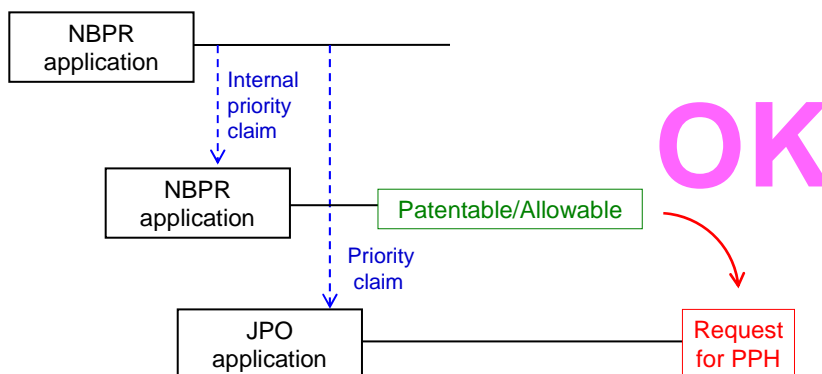

I

(Case III)

- Paris route, but the first application is from the third country -

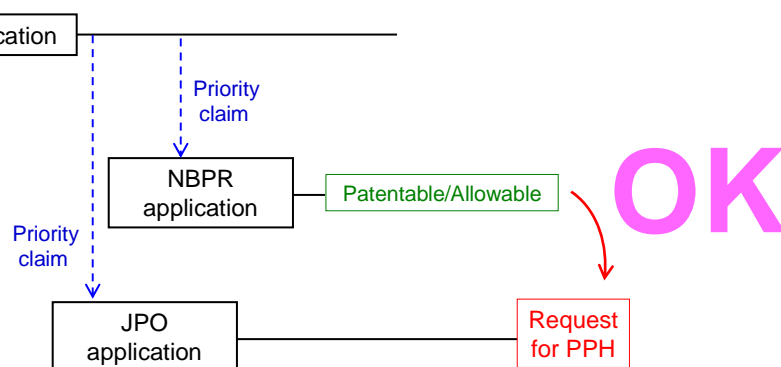

-- : the office other than the JPO and the NBPR

J

(Case III)

- PCT route, but the first application is from the third country -

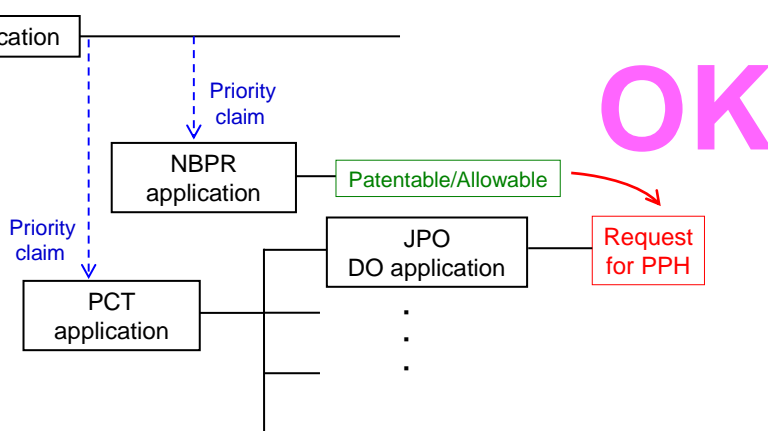

-- : the office other than the JPO and the NBPR

K

(Case III)
- PCT route -

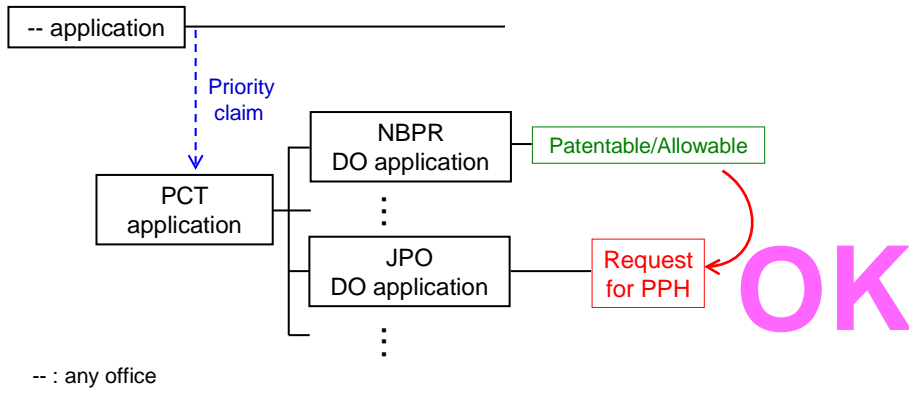

L

(Case III)
- Direct PCT & PCT route -

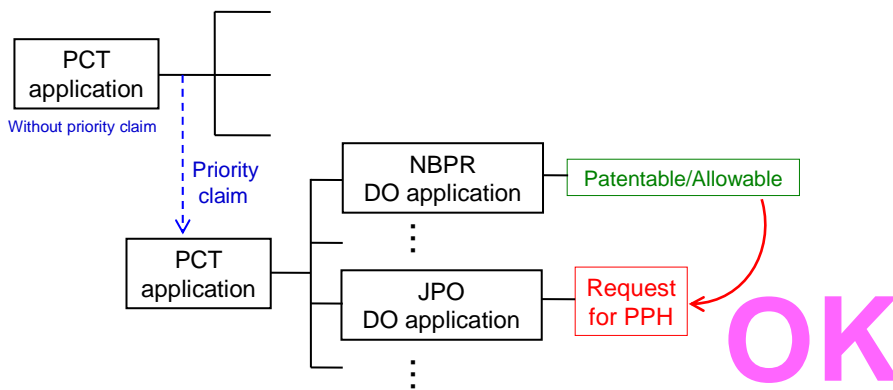

M

(Case IV)
- Direct PCT route -

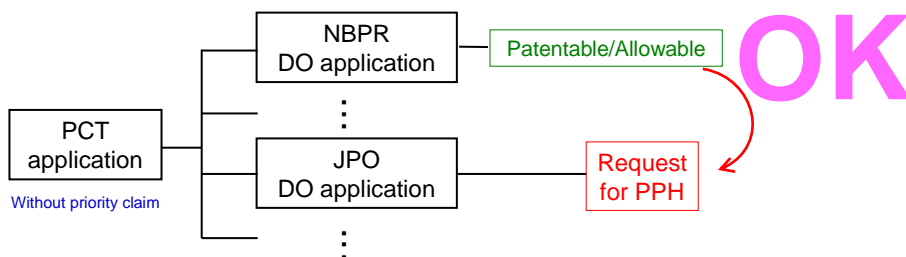

N

A case not meeting requirement (d)
- Examination has begun before a request for PPH -

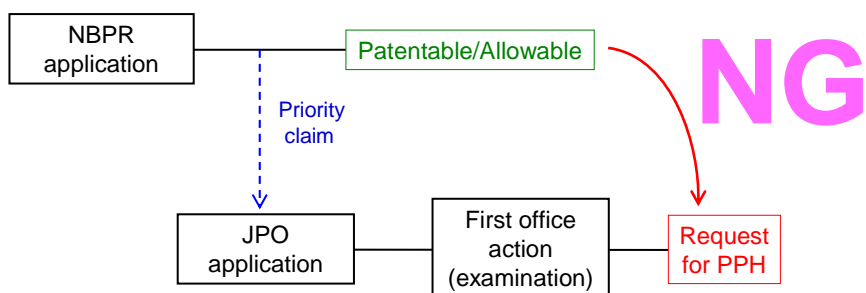

(A) The application is a national phase application of the corresponding international application.

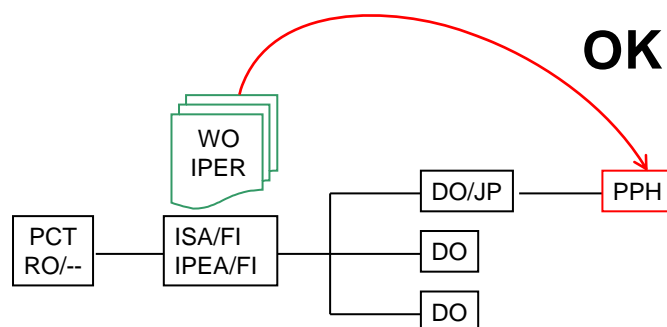

(A') The application is a national phase application of the corresponding international application.

(The corresponding international application claims priority from a national application.)

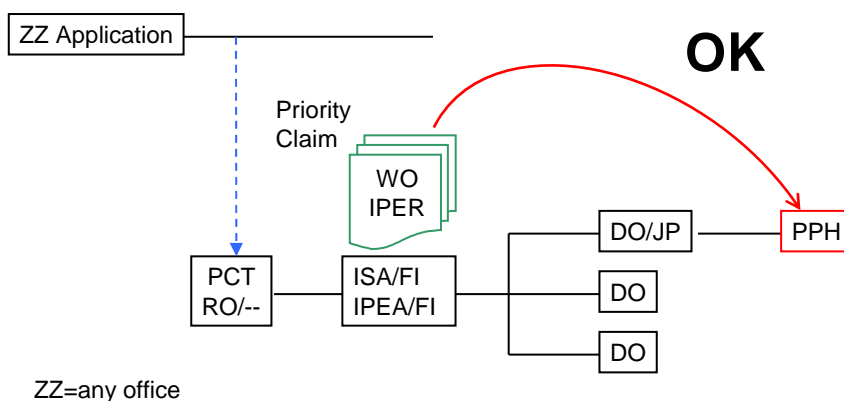

(A'') The application is a national phase application of the corresponding international application.

(The corresponding international application claims priority from an international application.)

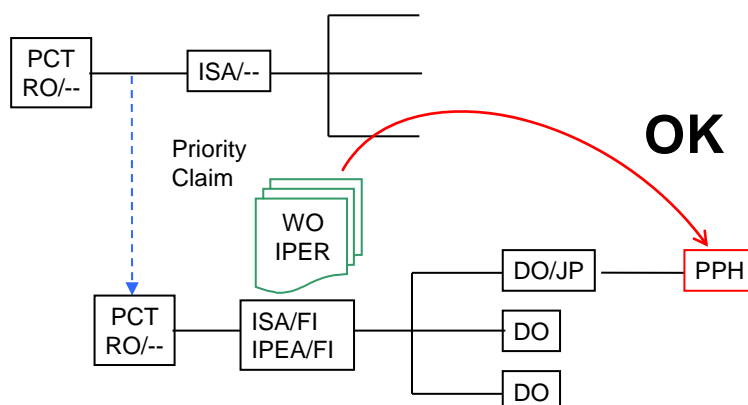

(B) The application is a national application as a basis of the priority claim of the corresponding international application.

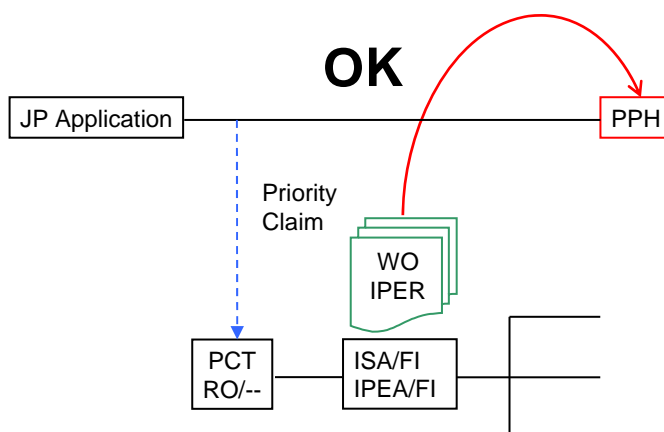

(C) The application is a national phase application of an international application claiming priority from the corresponding international application.

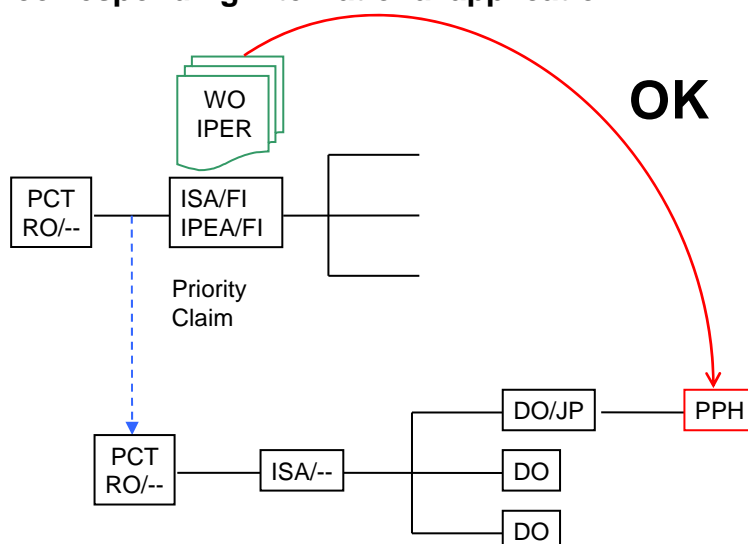

(D) The application is a national application claiming foreign/domestic priority from the corresponding international application.

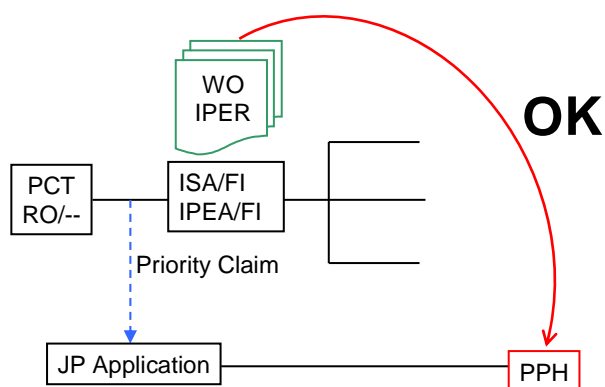

(E1) The application is a divisional application of an application which satisfies the requirement (A).

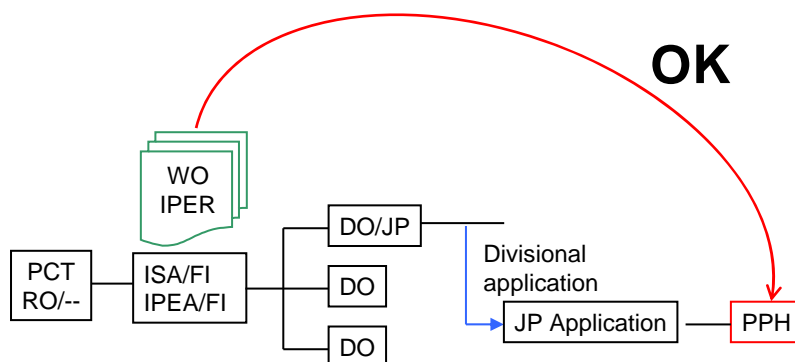

(E2) The application is an application claiming domestic priority from an application which satisfies the requirement (B).

