

# Revised procedures to file a request to the JPO for the Patent Prosecution Highway Pilot Program between the JPO and the DPMA

## **0. The outline of the Patent Prosecution Highway program**

The Patent Prosecution Highway (PPH) program enables an application whose claims are determined to be patentable in the Office of First Filing (OFF) to undergo an accelerated examination in the Office of Second Filing (OSF) with a simple procedure according to a request from an applicant.

## **1. Request to the JPO**

When an applicant files a request for an accelerated examination under the PPH pilot program to the Japan Patent Office, an applicant should submit a request form “The Explanation of Circumstances Concerning Accelerated Examination” based on the procedure prescribed in “the Guidelines of the Accelerated Examination and Appeal”.

Under the PPH pilot program, an applicant is not required to fill in the section [2. the disclosure of prior arts and comparison between the claimed invention and prior art] in “The Explanation of Circumstances Concerning Accelerated Examination”, if the application, filed to the JPO, satisfies following conditions (1) and the applicant attaches following documents (2) to it.

### **(1) Requirements for requesting accelerated examination under the PPH pilot program at the JPO**

- (a) The JPO application (including PCT national phase application) is
- (i) an application which validly claims priority under Paris Convention to the DPMA application(s) (examples are provided in Annex, figure A, B, F, G and I or
  - (ii) an PCT national phase application without priority claim (examples are provided in Annex, figure J), or
  - (iii) an application which validly claims priority under Paris Convention to the PCT application(s) without priority claim (examples are provided in Annex, figure K, L and M).

The JPO application, which validly claims priority to multiple DPMA or PCT applications, or which is the divisional application based on the originally filed application that is included in (i) to (iii) above, is also eligible.

- (b) At least one corresponding DPMA application has one or more claims that are determined

to be patentable by the DPMA<sup>1</sup>.

(c) All claims in the JPO application for which accelerated examination under the PPH pilot program is requested must sufficiently correspond to one or more of those claims indicated as patentable in the DPMA.

Claims shall be considered to sufficiently correspond where the claims are of the same or similar scope. For the purposes of the JPO, “claims are of the same or similar scope” means that the claims must have a common technical feature which made the claims allowable over the prior art in the DPMA application.

Please note that when claims are determined to be patentable by the DPMA by making amendment to claims, the claims in the JPO also should be amended similar way to sufficiently correspond to the patentable claims in the DPMA application.

(d) The JPO has not begun examination of the application.

**(2) The documents that the applicant should attach to “The Explanation of Circumstances Concerning Accelerated Examination”.**

a. Copies of all office actions in the DPMA<sup>2</sup>, which were sent for the corresponding application by the DPMA examiner, and translation of them<sup>3</sup>.

Both Japanese and English are acceptable as translation language.

b. Copies of all claims determined to be patentable by the DPMA, and translation of them<sup>3</sup>.

Both Japanese and English are acceptable as translation language.

c. Copies of references cited by DPMA examiner

Copies of patent documents cited by the DPMA will not be needed where they are freely available on the JPO’s patent databases. In the case that the JPO doesn’t possess the patent documents, examiners may require the submission of the patent documents. Any translation of cited documents is not needed.

d. The explanation table of sufficiently corresponding claims

---

<sup>1</sup> This is the case where the DPMA patent examiner clearly identifies those claims to be patentable. When an DPMA examiner offers an amendment of claims in the final-communication which leads to a patent grant if the applicant shows his attitude to accept it, the amendment shall be a basis of request for the PPH pilot program.

<sup>2</sup> Office actions in the DPMA mean “Recherchebericht”, “Prüfungsbescheide” and “Erteilungsbeschluss”.

<sup>3</sup> Machine translations will be admissible, but if it is impossible for the examiner to understand the outline of the translated office action or claims due to insufficient translation, the examiner can request the applicant to resubmit translations.

Applicant should attach an explanation table to explain how the claims indicated as patentable in the DPMA sufficiently correspond to the claims in the JPO application.

When claims are just literal translation, the applicant can just write down that “they are same” in the table. When claims are not just literal translation, it is necessary to explain the sufficient correspondence of each claim based on the criteria (1)(c).

When the applicant has already submitted above documents (a. to d.) to the JPO through simultaneous or past procedures, the applicant can incorporate the documents by reference and does not have to attach them.

When the application doesn't fulfill the requirement of (1) and (2), then the applicant cannot omit to fill in the section [2. the disclosure of prior arts and comparison between the claimed invention and prior art] and the request of accelerated examination is not accepted. In that case, the JPO will notify that and the reason for it to the applicant (or the representative).

## **2. Example of “The Explanation of Circumstances Concerning Accelerated Examination” for filing request accelerated examination under the PPH pilot program**

### (1) Circumstances

The applicant should indicate that the application (including PCT national phase application) is an application validly claiming the priority under Paris Convention to the corresponding DPMA application, and the accelerated examination is requested under the PPH pilot program here. And the application number of the corresponding application(s), publication number, or a patent number also should be written.

\*In the case that the application which has one or more claims that are determined to be patentable is different from the one that is a base of the priority (for example, the divisional application of the basic application), the application number, publication number, or a patent number of the application(s) that is a base of the priority, and the relationship between the application which has claim(s) determined to be patentable should also be written.

### (2) The submitted documents

The applicant should list all required documents mentioned above 1.(2) in an identifiable way.

### (3) Notice

Forms of “The Explanation of Circumstances Concerning Accelerated Examination” are different between on-line procedure and paper procedure. So please refer to the examples of forms when filling in (“Accelerated Examination form1” for on-line procedures, and “Accelerated Examination form2” for paper procedures.).

## Example form of on-line procedures

【書類名】	早期審査に関する事情説明書	} Bibliographical items
The name of this paper		
【提出日】	平成00年00月00日	
Date of filing		
【あて先】	特許庁長官殿	
Destination		
【事件の表示】		
【出願番号】	特願 0000-000000	
Application number		
【提出者】		
【識別番号】	000000000	
【住所又は居所】	〇〇県〇〇市〇丁目	
【氏名又は名称】	〇〇〇〇	
The name and address of who submit this		
【代理人】		
【識別番号】	000000000	
【住所又は居所】	〇〇県〇〇市〇丁目	
【氏名又は名称】	〇〇 〇〇	
The name and address of the attorney		
【早期審査に関する事情説明】		
The explanation of circumstances concerning accelerated examination		
1. 事情		
本出願はドイツ特許商標庁への出願(特許出願番号0000000)をパリ条約に基づく優先権の基礎出願とする出願であり、特許審査ハイウェイに基づく早期審査の申請を行うものである。		
1. Circumstances		
This application is an application validly claiming the priority under Paris Convention to the corresponding DPMA application (the application number is 0000000), and the accelerated examination is requested under the PPH pilot program.		
以下において、「引用非特許文献1」とは、「村岡洋一著、「コンピュータサイエンス大学講座(第11巻)コンピュータ・アーキテクチャ」、第2版、株式会社近代科学者、1985年11月、p.123-127」である。		
In what follows, “non-patent literature1” is “Yoichi Muraoka, Lecture of Computer Science (vol.11) computer architecture, 2 <sup>nd</sup> edition, Scientist com, Nov. 1985, p.123-127.”		
If the name of the document is long (over than 50 letters), it is impossible to write it down directly to the column “【物件名】.” Please write down the full name of the document in the column “【早期審査に関する事情説明】” and name it properly. Then write the name in the column “【物件名】.”		

【提出物件の目録】

List up the documents to be submitted

The list of submitted documents

- 【物件名】 ドイツ出願と本出願の請求項の対応関係を示す書面 1
- 【物件名】 \*\*年\*\*月\*\*日付の対応ドイツ出願に対する調査報告書の写し 1
- 【物件名】 \*\*年\*\*月\*\*日付の対応ドイツ出願に対する拒絶理由通知書の写し 1
- 【物件名】 \*\*年\*\*月\*\*日付の対応ドイツ出願に対する特許査定書の写し 1
- 【物件名】 対応ドイツ出願の特許公報である英国公告第00000号公報 1
- 【物件名】 対応ドイツ出願に対して引用されたドイツ出願公開00000号公報 1
- 【物件名】 対応ドイツ出願に対して引用された日本国特許第00000号公報 1
- 【物件名】 引用非特許文献1 1

- (The name of the document) The table to explain how the claims indicated as allowable in the DPMA sufficiently correspond to the claims in the JPO application 1
- (The name of the document) Copy of search report in the DPMA on (date) 1
- (The name of the document) Copy of examination report in the DPMA on (date) 1
- (The name of the document) Copy of notification of grant in the DPMA on (date) 1
- (The name of the document) Corresponding application's patent publication: German Patent number 0000000 1
- (The name of the document) Cited reference of the corresponding DPMA application: German Publication of application 0000000 1
- (The name of the document) Cited reference of the corresponding DPMA application: Japan Patent publication of application 0000000 1
- (The name of the document) Cited non patent literature 1

Use the same name as “【物件名】” under “【提出物件の目録】.”

Attach the document here as image file or text.

【添付物件】

The list of attached documents

- 【物件名】 ドイツ出願と本出願の請求項の対応関係を示す書面

The table to explain how the claims indicated as allowable in the DPMA sufficiently correspond to the claims in the JPO application

【内容】

本出願の請求項	ドイツで特許可能とされた請求項	対応関係に関するコメント
The claim in the JPO	The patentable claim in the DPMA	Comments about the correspondence
1	1	両クレームは同一である。 Both claims are the same.
2	2	”

3	1	両クレームは、記載形式を除き同一である。 Both claims are the same except the claim format.
4	2	”
5	1	請求項5は、ドイツの請求項1にAという構成を付加したものである。 The claim 5 in the JPO adds the composition A to the Claim 1 in the DPMA

【物件名】 引用非特許文献1

Non-patent literature1

【内容】

Attach the copy of the document.

Use the same name as “【物件名】” under “【提出物件の目録】.”

Note that in the case of paper procedure, the pendency period (the period between the request for PPH and the first office action) tends to be longer than on-line procedure.

**A** A case meeting requirement (a) (i)  
- Paris route -

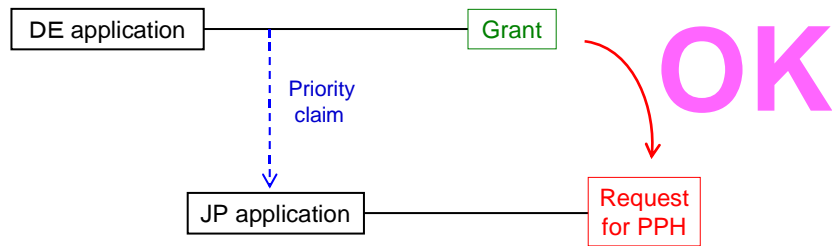

**B** A case meeting requirement (a) (i)  
- PCT route -

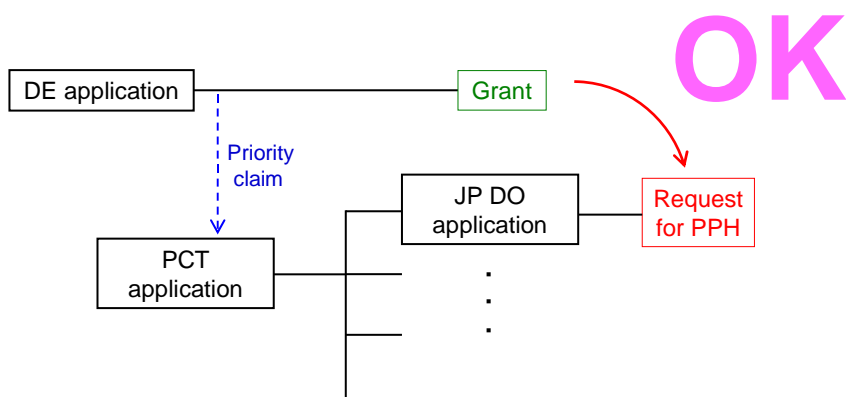

**C** A case not meeting requirement (a)  
 - Paris route, but the first application is from the third country -

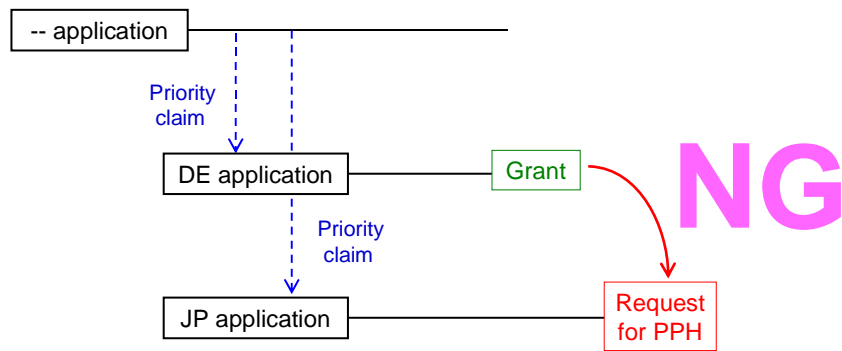

-- : the office other than the DPMA

**D** A case not meeting requirement (a)  
 - PCT route, but the first application is from the third country -

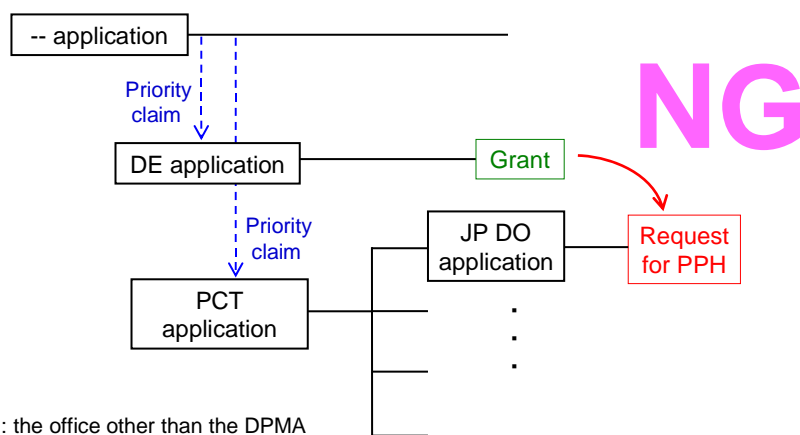

-- : the office other than the DPMA

**E** A case meeting requirement (b)  
- Search Report -

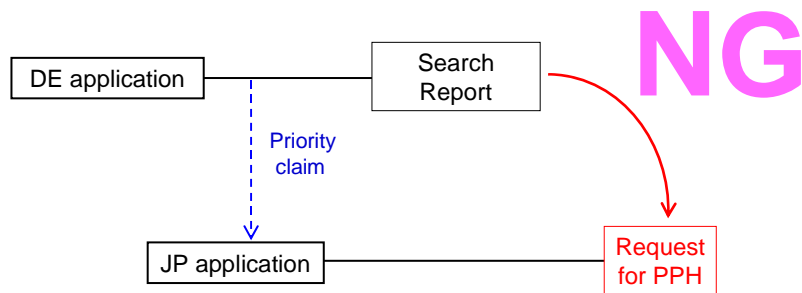

**F** A case meeting requirement (a) (i)  
- Paris route & Complex priority -

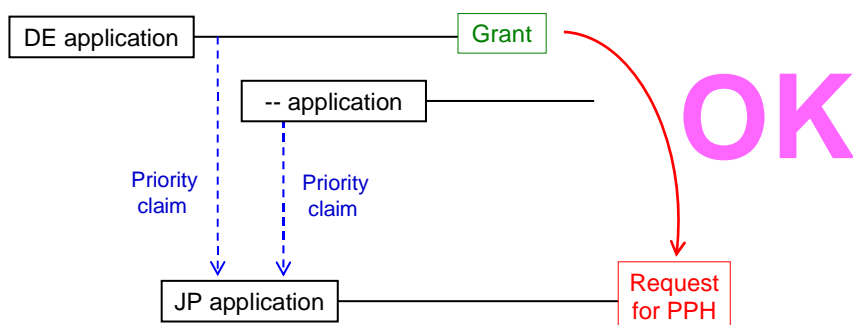

-- : any office

**G** A case meeting requirement (a) (i)  
- Paris route & Internal priority -

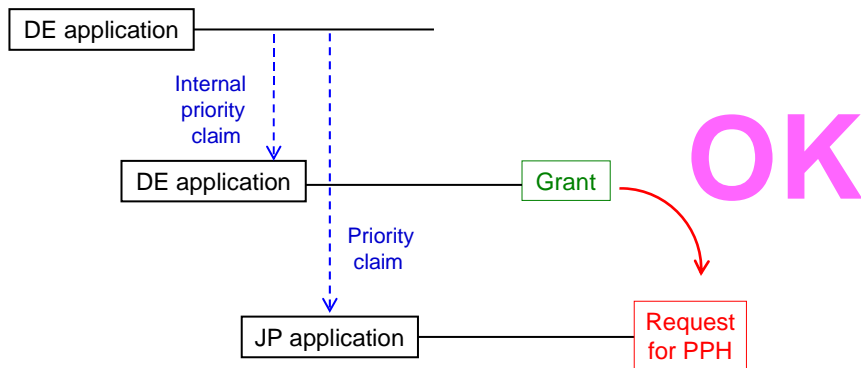

**H** A case meeting requirement (a) (i)  
- Paris route & divisional application -

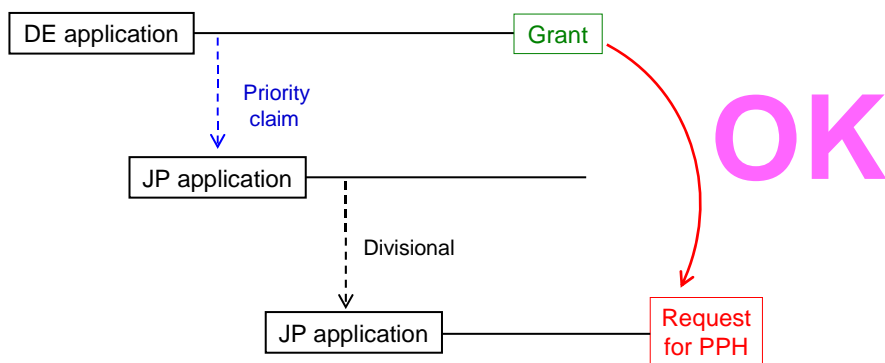

**I** A case meeting requirement (a) (i)  
- PCT route -

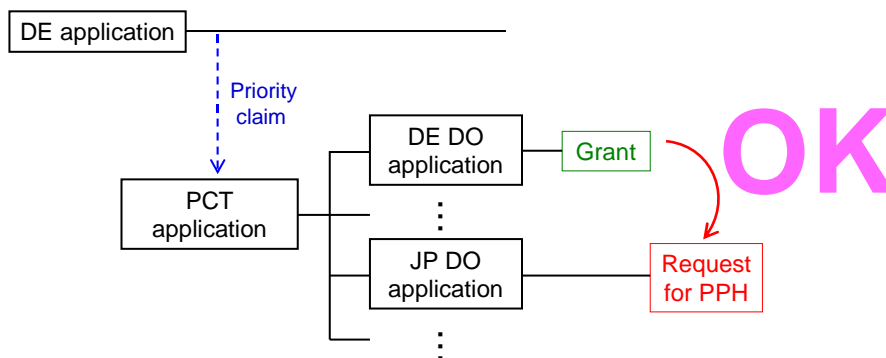

**J** A case meeting requirement (a) (ii)  
- Direct PCT route -

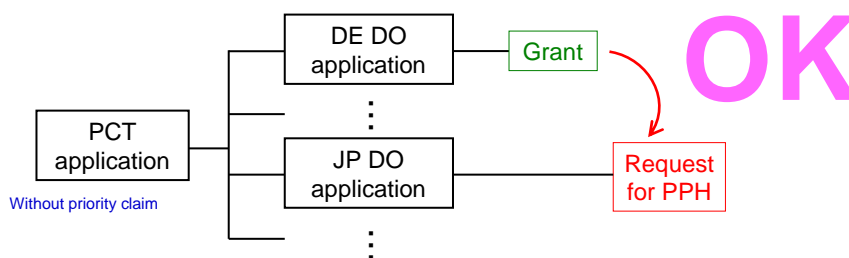

**K** A case meeting requirement (a) (iii)  
- Direct PCT & Paris route -

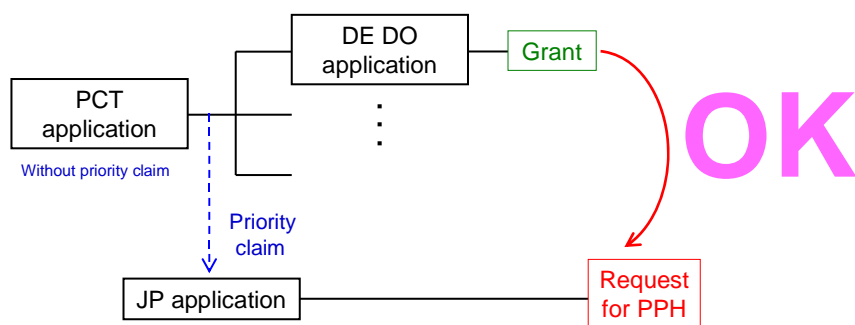

**L** A case meeting requirement (a) (iii)  
- Direct PCT & PCT route -

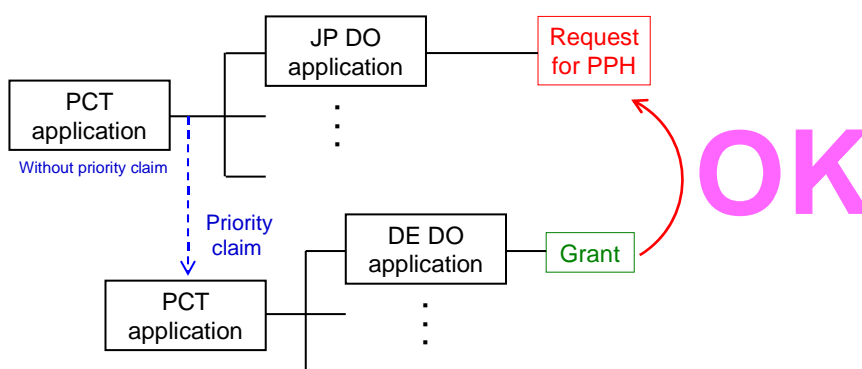

**M** A case meeting requirement (a) (iii)  
- Direct PCT & PCT route -

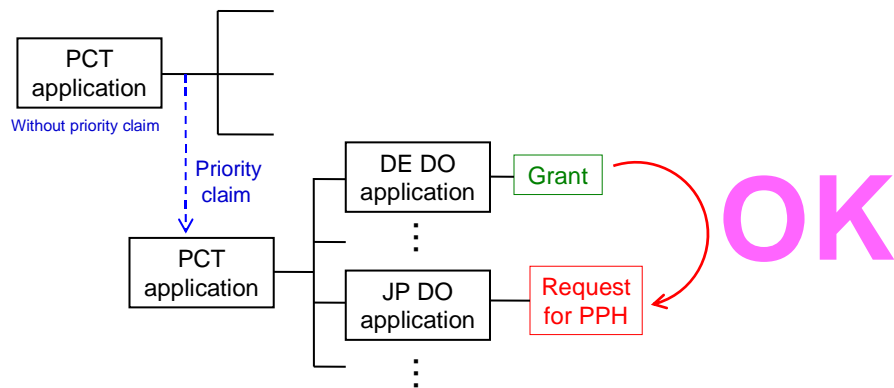

**N** A case not meeting requirement (d)  
- Examination has begun before a request for PPH -

