

Procedures to file a request to the IMPI for Patent Prosecution Highway Pilot Program between the IMPI (Instituto Mexicano de la Propiedad Industrial) and the JPO (Japan Patent Office)

Part I

PPH using the national work products from the JPO

Applicants can request accelerated examination by a prescribed procedure including submission of relevant documents on an application which is filed with the IMPI and satisfies the following requirements under the IMPI-JPO Patent Prosecution Highway (PPH) pilot program.

When filing a request for the PPH pilot program, an applicant must submit a free style writing before the Institute. (See section 3)

The Offices may terminate the PPH pilot program if the volume of participation exceeds manageable level, or for any other reason. Ex Ante notice will be published if the PPH pilot program is terminated.

1. Requirements

(a) *The IMPI application (including a PCT national phase application) is:*

- (i) *an application which validly claims priority under the Paris Convention to the JPO application(s) (examples are provided in ANNEX I, Figure A, B, C, F, G and H), or***
- (ii) *a PCT national phase application without priority claim (examples are provided in Annex I, Figure I and K), or***
- (iii) *an application which validly claims priority under the Paris Convention to the PCT application(s) without priority claim (examples are provided in ANNEX I, Figure J and L).***

The IMPI application, which validly claims priority to multiple JPO or direct PCT applications, or which is the divisional application validly based on the originally filed application that is included in (i) to (iii) above, is also eligible.

(b) *At least one corresponding application exists in the JPO and has one or more claims that are determined to be patentable/allowable by the JPO.*

The corresponding application(s) can be the application which forms the basis of the priority claim, an application which derived from the same (e.g., a divisional application of the JPO application or an application which claims domestic priority to the JPO application (see Figure C in Annex I)), or an JPO national phase application of a PCT application (see Figures H, I, J, K and L in Annex I).

Claims are “determined to be allowable/patentable” when the JPO examiner clearly identified the claims to be allowable/patentable in the latest office action, even if the application is not granted for patent yet.

The office action includes:

- (a) Decision to Grant a Patent
- (b) Notification of Reasons for Refusal
- (c) Decision of Refusal
- (d) Appeal Decision

For example, if the following routine expression is described in the “Notification of Reason for Refusal” of the JPO, those claims are clearly identified to be allowable/patentable.

“<Claims which has been found no reason for refusal>

At present for invention concerning Claim___, no reason for refusal is found.”

(c) All claims on file, as originally filed or as amended, for examination under the PPH must sufficiently correspond to one or more of those claims indicated as allowable in the JPO.

Claims are considered to “sufficiently correspond” where, accounting for differences due to translations and claim format, the claims in the IMPI are of the same or similar scope as the claims in the JPO, or the claims in the IMPI are narrower in scope than the claims in the JPO.

In this regard, a claim that is narrower in scope occurs when a JPO claim is amended to be further limited by an additional feature that is supported in the specification (description and/or claims).

A claim in the IMPI which introduces a new/different category of claims to those claims indicated as allowable in the JPO is not considered to sufficiently correspond. For example, the JPO claims only contain claims to a process of manufacturing a product, then the claims in the IMPI are not considered to sufficiently correspond if the IMPI claims introduce product claims that are dependent on the corresponding process claims.

Any claims amended or added after the grant of the request for participation in the PPH pilot program need not to sufficiently correspond to the claims indicated as patentable/allowable in the JPO application. However, if any amended claim does not satisfy the claim correspondence, the application is treated as the usual application (i.e. it gets out of Fast Track).

(d) The IMPI has not begun examination of the application at the time of request for the

PPH. (See Figure M in ANNEX I)

2. Documents to be submitted

Documents (a) to (d) below must be submitted by attaching to the PPH request.

- (a) Copies of all office actions (which are relevant to substantial examination for patentability in the JPO) which were issued for the corresponding application by the JPO, and translations of them¹.**

The applicant does not have to submit a copy of JPO office actions and translations of them when the office actions are provided via AIPN (JPO's dossier access system). If the office actions cannot be obtained by the IMPI examiner via the AIPN, the applicant may be notified and requested to provide the necessary documents.

- (b) Copies of all claims determined to be patentable/allowable by the JPO, and translations of them.**

The applicant does not have to submit a copy of claims indicated to be allowable/patentable in the JPO, and translations thereof when the claims are provided via AIPN (JPO's dossier access system). If the claims cannot be obtained by the IMPI examiner via the AIPN, the applicant may be notified and requested to provide the necessary documents.

- (c) Copies of references cited by the JPO examiner**

If the references are patent documents, the applicant does not have to submit them because the IMPI usually possesses them. When a patent document is not available to the IMPI examiner, the applicant must submit it at the examiner's request. Non-patent literature must always be submitted.

The translations of the references are unnecessary

- (d) Claim correspondence table**

The applicant requesting PPH must submit a claim correspondence table, which indicates how all claims in the IMPI application sufficiently correspond to the patentable/allowable claims in the JPO application.

When claims are just literal translation, the applicant can just write down that "they are the same" in the table. When claims are not just literal translation, it is necessary to explain the sufficient correspondence of each claim.

¹ Machine translations will be admissible, but if it is impossible for the examiner to understand the outline of the translated office action or claims due to insufficient translation, the examiner can request the applicant to resubmit translations.

When the applicant has already submitted above documents (a) to (d) to the IMPI through simultaneous or past procedures, the applicant may incorporate the documents by reference and does not have to attach them.

3. Sample text for participating under the PPH pilot program.

(1) The circumstances

When an applicant files a petition for an accelerated examination under the PPH before IMPI, the applicant shall submit its application in writing explaining the circumstances for its participation, according to the guidelines described in this document.

The applicant shall indicate that the application is included in subparagraphs (i) to (iii) of section 1 (a), and that the accelerated examination is requested under the PPH pilot program. The application number, publication number, or patent number of the corresponding JPO application(s) also shall be presented.

In the event that the application which has one or more claims that are indicated as allowable is different from those presented in the JPO application included in subparagraphs (i) to (iii) of section 1 (a) (for example, a divisional application of the initial application), the application number, publication number or patent number of the application(s) which contains patentable/allowable claims and the relationship among these applications must also be explained in the writing.

(2) Documents to be submitted

The applicant must list all required documents in section 2, on an identifiable way, even if the applicant omits to submit certain documents.

(3) Sample of free style writing

Lugar y Fecha

Asunto: Petición para participar en el Programa Piloto PPH

Número de solicitud ante el IMPI

Fecha de presentación

Título de la invención

Solicitante

Apoderado, representante legal o mandatario

Domicilio para oír y recibir notificaciones

Instituto Mexicano de la Propiedad Industrial

Dirección Divisional de Patentes

PRESENTE

Por este conducto, se solicita la inclusión de la solicitud de patente con número de expediente MX/a/ / / dentro del Programa Piloto del PPH correspondiente a la solicitud de patente japonesa JP XXXXXX y que cumple con la relación prevista en el inciso (X) del punto 1 (a) (explique la razón por qué cumple con esa relación).

Para efectos de lo anterior se enlistan los documentos que se anexan y los que no se anexan por estar disponibles a través del sistema AIPN o ser documentos de patente.

- (a) Copia de todas las acciones oficiales que fueron relevantes para determinar la patentabilidad de la solicitud de patente en JPO, que fueron emitidas para la solicitud JPO correspondiente y, en su caso, su traducción son:

1. Acción oficial 1 (no se anexa por estar disponible en AIPN)
2. ...

(b) Copia de todas las reivindicaciones que han sido indicadas como otorgables por JPO y, en su caso, su traducción:

1. Las reivindicaciones otorgables son las originalmente presentadas ante la JPO. (no se anexan por estar disponibles en AIPN)

(c) Copia de todas las referencias citadas por el examinador de JPO:

1. JPXXXXXX (no se anexa por ser documento de patente)
2.

(d) Tabla de correspondencia de reivindicaciones:

Tabla de correspondencia de reivindicaciones		
Reivindicaciones en la solicitud en el IMPI	Reivindicaciones otorgables en la solicitud JPO	Explicación sobre la suficiente correspondencia
XXX	XXX	Son lo mismo
XYX	XYZ	Justificación de la suficiente correspondencia
...

Nombre y firma del solicitante o apoderado.

Part II

PPH using the PCT international work products from the JPO

Applicants can request accelerated examination by a prescribed procedure including submission of relevant documents on an application which is filed with the IMPI and satisfies the following requirements under the IMPI-JPO Patent Prosecution Highway pilot program based on PCT international work products (PCT-PPH pilot program).

When filing a request for the PCT-PPH pilot program, an applicant must submit a free style writing before the IMPI. (See section 3).

The Offices may terminate the PCT-PPH pilot program if the volume of participation exceeds manageable level, or for any other reason. Ex Ante notice will be published if the PPH pilot program is terminated.

1. Requirements

The application which is filed with the IMPI and on which the applicant files a request under the PCT-PPH must satisfy the following requirements:

- (1) The latest work product in the international phase of a PCT application corresponding to the application (“international work product”), namely the Written Opinion of International Search Authority (WO/ISA), the Written Opinion of International Preliminary Examination Authority (WO/IPEA) or the International Preliminary Examination Report (IPER), indicates at least one claim as patentable/allowable (from the aspect of novelty, inventive steps and industrial applicability).**

Note that the ISA and the IPEA which produced the WO/ISA, WO/IPEA and the IPER are limited to the JPO, but, if priority is claimed, the priority claim can be to an application in any Office, see example A' in Annex II (application ZZ can be any national application).

The applicant cannot file a request under PCT-PPH on the basis of an International Search Report (ISR) only.

In case any observation is described in Box VIII of WO/ISA, WO/IPEA or IPER which forms the basis of a PCT-PPH request, the applicant must explain why the claim(s) is/are not subject to the observation irrespective of whether or not an amendment is submitted to correct the observation noted in Box VIII. The application will not be eligible for participating in PCT-PPH pilot program if the applicant does not explain why the claim(s) is/are not subject to the observation. In this regard, however, it does not affect the decision on the eligibility of the application whether the explanation is adequate and/or whether the amendment submitted overcomes the observation noted in Box VIII.

(2) The relationship between the application and the corresponding international application satisfies one of the following requirements:

- (A) The application is a national phase application of the corresponding international application. (See Figures A, A', and A'' in Annex II)
- (B) The application is a national application as a basis of the priority claim of the corresponding international application. (See Figure B in Annex II)
- (C) The application is a national phase application of an international application claiming priority from the corresponding international application. (See Figure C in Annex II)
- (D) The application is a national application claiming foreign/domestic priority from the corresponding international application. (See Figure D in Annex II)
- (E) The application is the derivative application (divisional application and application claiming domestic priority etc.) of the application which satisfies one of the above requirements (A) – (D). (See Figures E1 and E2 in Annex II)

(3) All claims on file, as originally filed or as amended, for examination under the PCT-PPH must sufficiently correspond to one or more of those claims indicated as allowable in the latest international work product of the corresponding international application.

Claims are considered to “sufficiently correspond” where, accounting for differences due to translations and claim format, the claims of the application are of the same or similar scope as the claims in the latest international work product, or the claims of the application are narrower in scope than the claims in the latest international work product.

In this regard, a claim that is narrower in scope occurs when a claim indicated as allowable in the latest international work product is amended to be further limited by an additional feature that is supported in the specification (description and/or claims).

A claim of the application which introduces a new/different category of claims to those claims indicated as allowable in the latest international work product is not considered to sufficiently correspond. For example, the claims indicated as allowable in the latest international work product only contain claims to a process of manufacturing a product, then the claims of the application are not considered to sufficiently correspond if the claims of the application introduce product claims that are dependent on the corresponding process claims.

Any claims amended or added after the grant of the request for participation in the PPH pilot program need not to sufficiently correspond to the claims indicated as patentable/allowable in the JPO application. However, if any amended claim does not satisfy the claim correspondence, the application is treated as the usual application (i.e. it gets out of Fast Track).

- (4) **The IMPI has not begun examination of the application at the time of request under PCT-PPH (See Figure F in Annex II)**

2. Documents to be submitted

The applicant must submit the following documents attached to the request form in filing a request under PCT-PPH. Some of the documents may not be required to submit in certain cases.

- (1) A copy of the latest international work product which indicated the claims to be patentable/allowable and their translations.**

In case the application satisfies the relationship 1.(2)(A), the applicant need not submit a copy of the International Preliminary Report on Patentability (IPRP) and any translations thereof because a copy of these documents is already contained in the file-wrapper of the application. In addition, if the copy of the latest international work product and the copy of the translation are available via “PATENTSCOPE (registered trademark)”², an applicant need not submit these documents, unless otherwise requested by the IMPI.

(WO/ISA and IPER are usually available as “IPRP Chapter I” and “IPRP Chapter II” respectively in 30 months after the priority date.)

- (2) A copy of a set of claims which the latest international work product of the corresponding international application indicated to be patentable/allowable and their translations.**

If the copy of the set of claims which are indicated to be patentable/allowable is available via “PATENTSCOPE (registered trademark)” (e.g. the international Patent Gazette has been published), an applicant need not submit this document unless otherwise requested by the IMPI. Where the set of claims is written in Japanese, the translations thereof must be still submitted by an applicant.

- (3) A copy of references cited in the latest international work product of the international application corresponding to the application.**

If the reference is a patent document, and it is not available to IMPI, this may be requested to applicant. Non-patent literature must always be submitted. Translations of cited references are unnecessary.

² <http://www.wipo.int/pctdb/en/index.jsp>

(4) A claims correspondence table which indicates how all claims in the application sufficiently correspond to the claims indicated to be patentable/allowable

When claims are just literal translation, the applicant can just write down that “they are the same” in the table. When claims are not just literal translation, it is necessary to explain the sufficient correspondence of each claim based on the criteria 1. (3) (Please refer to the Example form below).

When an applicant has already submitted the above mentioned documents (1) - (4) before the IMPI through simultaneous or past procedures, the applicant may incorporate the documents by reference and is thus not required to attach the documents.

3. Sample text for participating under the PCT-PPH pilot program.

(1) The circumstances

When an applicant files a petition for an accelerated examination under the PCT-PPH before the IMPI, the applicant shall submit its application in writing explaining the circumstances for its participation, according to the guidelines described in this document.

The applicant shall indicate that the request is included in subparagraphs (A) to (E) of section 1 (2), and that the accelerated examination is requested under the PCT-PPH pilot program. The international application number or the international publication number also shall be presented.

In the event that the application which has one or more claims that are determined to be patentable/allowable is different from those presented in the international application included in subparagraphs (A) to (E) of section 1 (2) (for example, a divisional application of the initial application), the international application number or the international publication number of the international application(s) which contains patentable/allowable claims and the relationship among these applications must also be explained in the writing.

(2) Documents to be submitted

The applicant must list all required documents in section 2, on an identifiable way, even if the applicant omits to submit certain documents.

(3) Sample of free style writing

Lugar y Fecha

Asunto: Petición para participar en el Programa Piloto PCT-PPH

Número de solicitud ante el IMPI

Fecha de presentación

Título de la invención

Solicitante

Apoderado, representante legal o mandatario

Domicilio para oír y recibir notificaciones

Instituto Mexicano de la Propiedad Industrial

Dirección Divisional de Patentes

PRESENTE

Por este conducto, se solicita la inclusión de la solicitud de patente con número de expediente MX/a/ / / dentro del Programa Piloto del PCT-PPH correspondiente a la fase nacional de la solicitud internacional XXXXXX y que cumple con la relación prevista en el inciso (X) del punto 1 (2) (explique la razón por qué cumple con esa relación).

Para efectos de lo anterior se enlistan los documentos que se anexan y los que no se anexan por estar disponibles a través del sistema PATENTSCOPE ® o ser documentos de patente.

- (a) Copia del último resultado de la fase internacional que indica las reivindicaciones que son patentables/otorgables y, en su caso, su traducción. (No se anexa por estar disponible en PATENTSCOPE)
- (b) Copia del capítulo reivindicatorio que de acuerdo con el último resultado de la fase internacional de la solicitud PCT correspondiente se indica

como patentable/otorgable y, en su caso, su traducción. . (No se anexa por estar disponible en PATENTSCOPE)

(c) Copia de las referencias citadas en el último resultado de la fase internacional de la solicitud PCT correspondiente a la solicitud.

1. JPXXXXX (no se anexa por ser documento de patente)

2.

(d) Tabla de correspondencia de reivindicaciones:

Tabla de correspondencia de reivindicaciones		
Reivindicaciones en la solicitud en el IMPI	Reivindicaciones otorgables en la solicitud internacional	Explicación sobre la suficiente correspondencia
XXX	XXX	Son lo mismo
XYY	XYZ	Justificación de la suficiente correspondencia
...

Nombre y firma del solicitante o apoderado.

A A case meeting requirement (a) (i)
- Paris route -

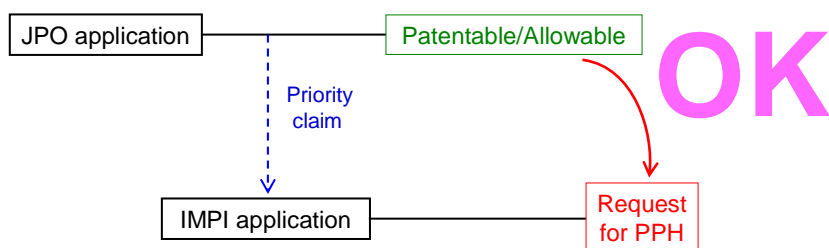

B A case meeting requirement (a) (i)
- PCT route -

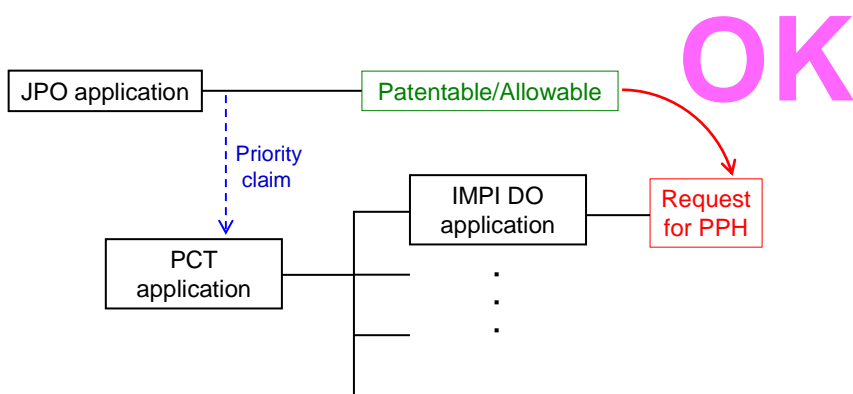

DO: Designated office

C A case meeting requirement (a) (i)
- Paris route, Domestic priority -

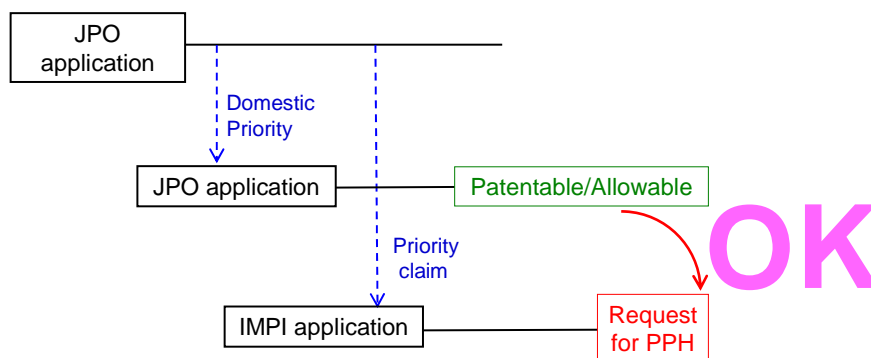

D A case not meeting requirement (a)
- Paris route, but the first application is from the third country -

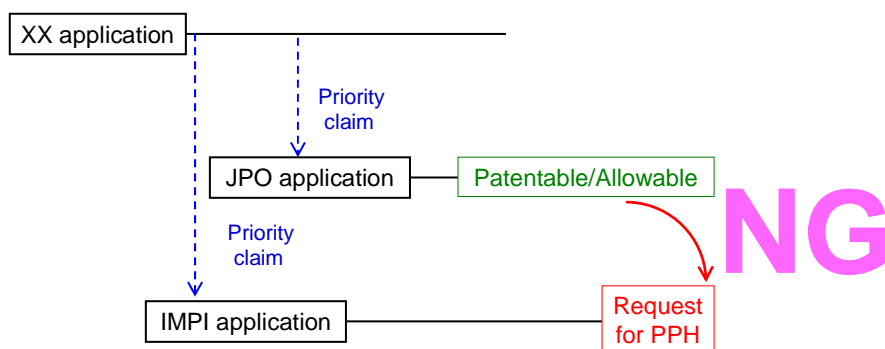

XX : the office other than the JPO

E A case not meeting requirement (a)
- PCT route, but the first application is from the third country -

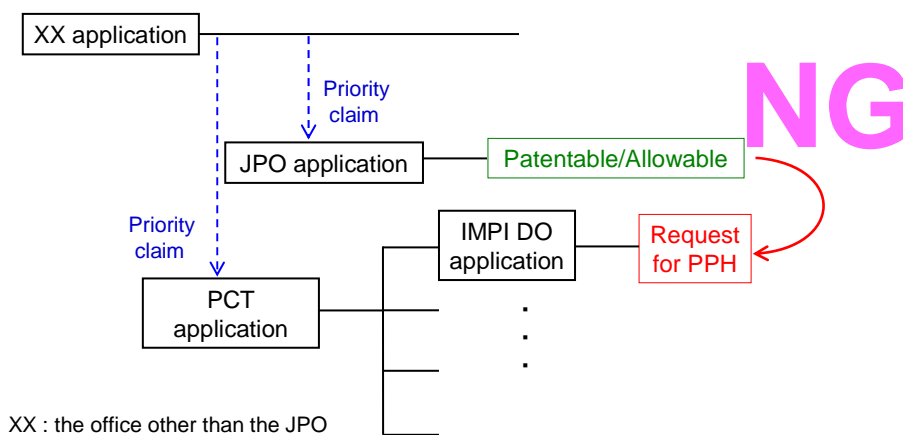

NG: Not granted

F A case meeting requirement (a) (i)
- Paris route & Complex priority -

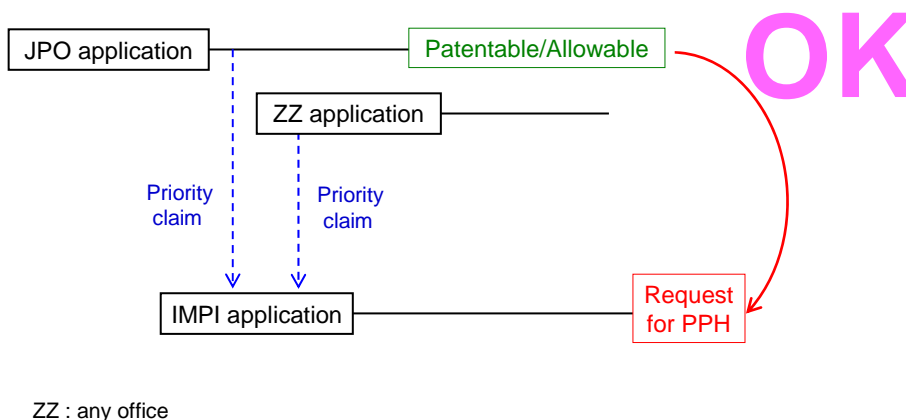

G A case meeting requirement (a) (i)
- Paris route & divisional application -

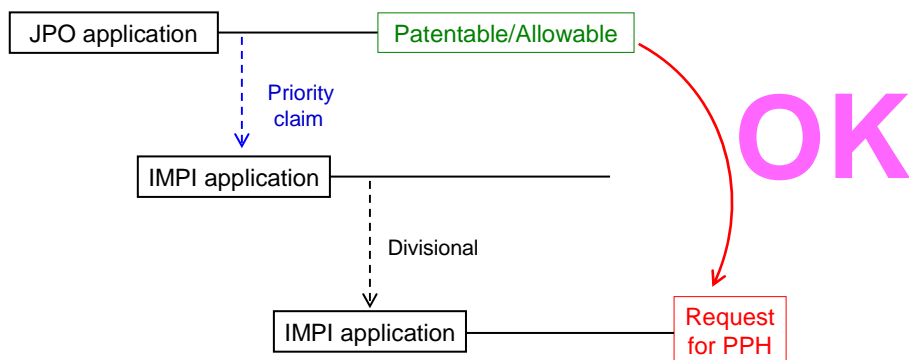

H A case meeting requirement (a) (i)
- PCT route -

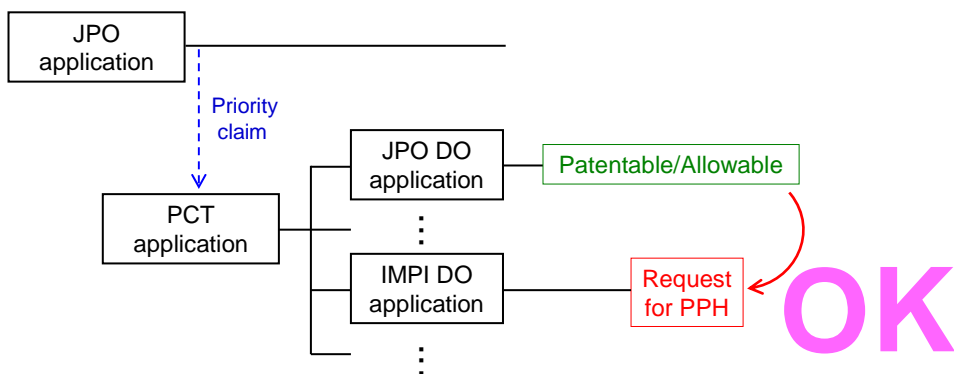

I A case meeting requirement (a) (ii)
- Direct PCT route -

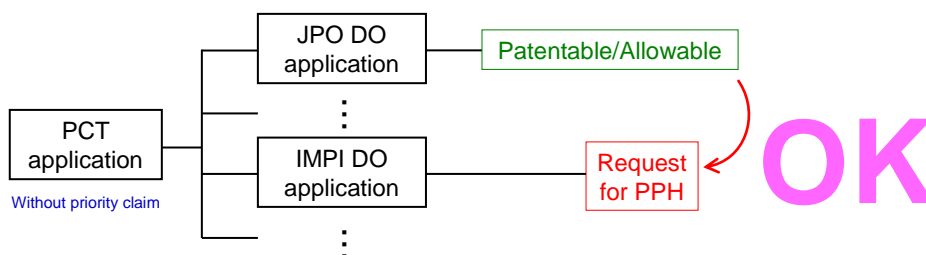

J A case meeting requirement (a) (iii)
- Direct PCT & Paris route -

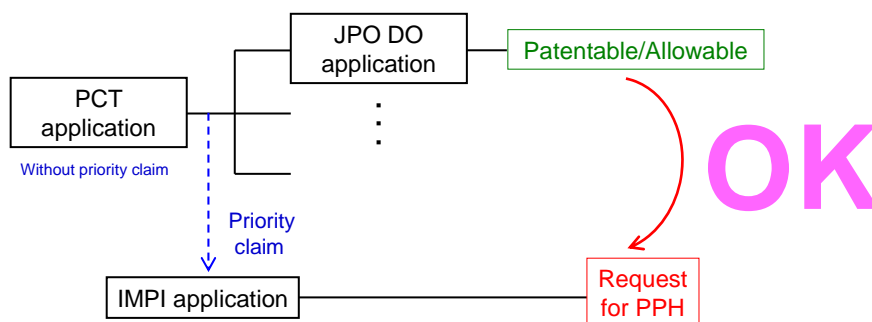

K A case meeting requirement (a) (ii)
- Direct PCT & PCT route -

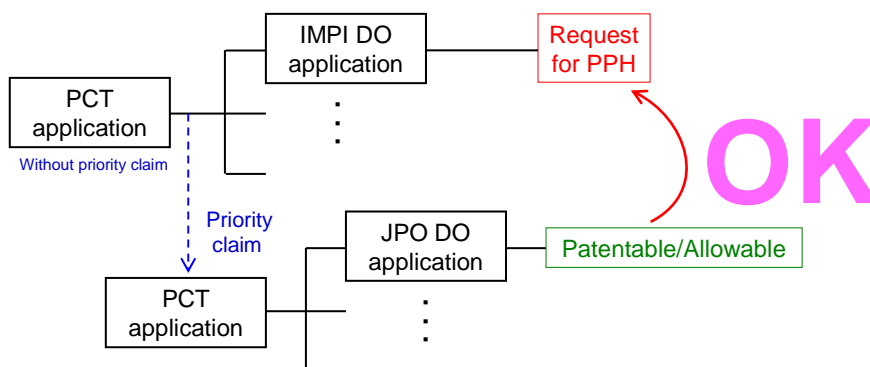

L A case meeting requirement (a) (iii)
- Direct PCT & PCT route -

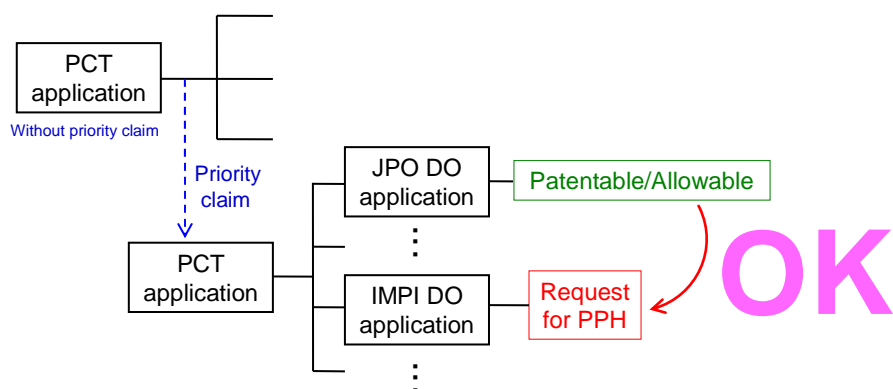

M A case not meeting requirement (d)
- Examination has begun before a request for PPH -

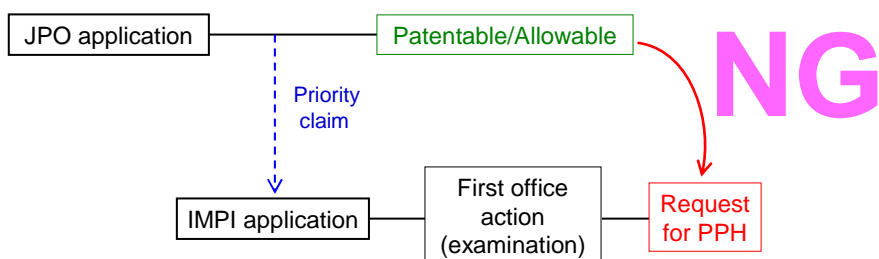

(A) The application is a national phase application of the corresponding international application.

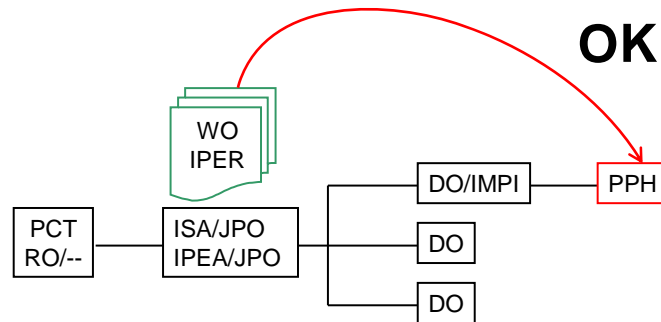

RO: Receiving Office

DO: Designated Office

(A') The application is a national phase application of the corresponding international application.

(The corresponding international application claims priority from a national application.)

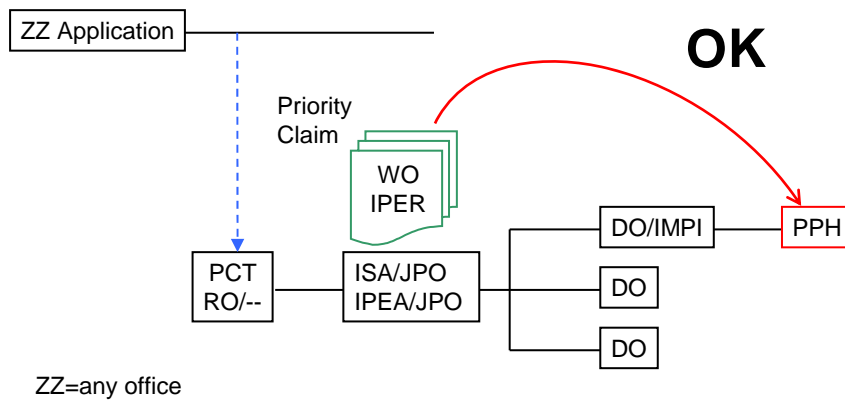

(A'') The application is a national phase application of the corresponding international application.

(The corresponding international application claims priority from an international application.)

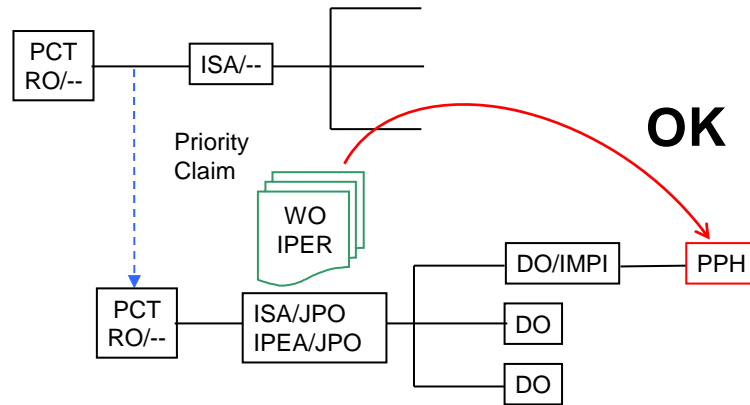

(B) The application is a national application as a basis of the priority claim of the corresponding international application.

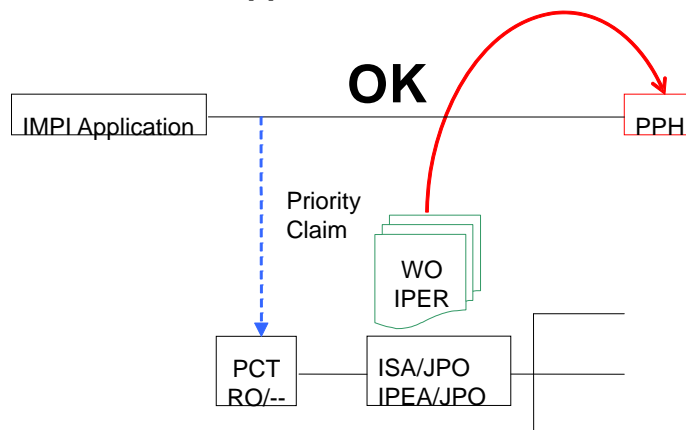

- (C) The application is a national phase application of an international application claiming priority from the corresponding international application.

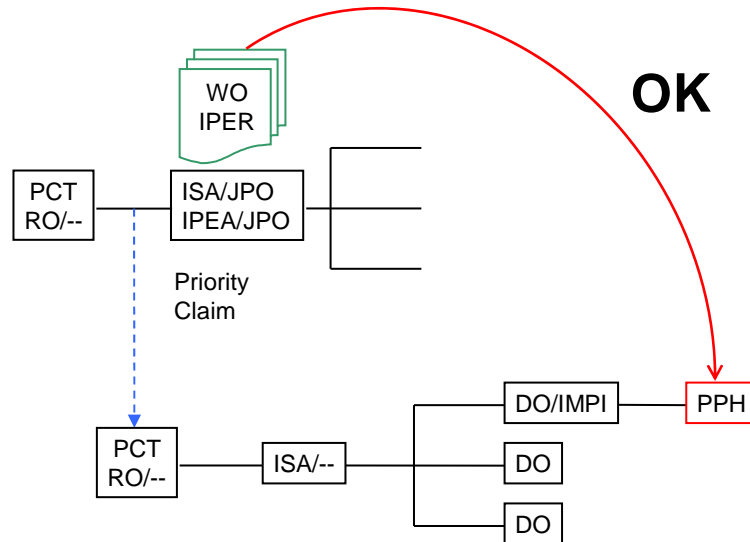

- (D) The application is a national application claiming foreign/domestic priority from the corresponding international application.

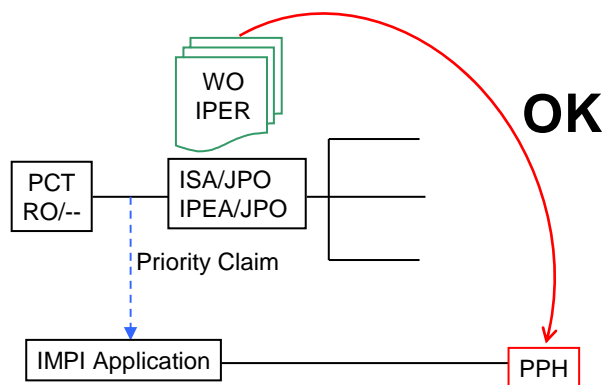

(E1) The application is a divisional application of an application which satisfies the requirement (A).

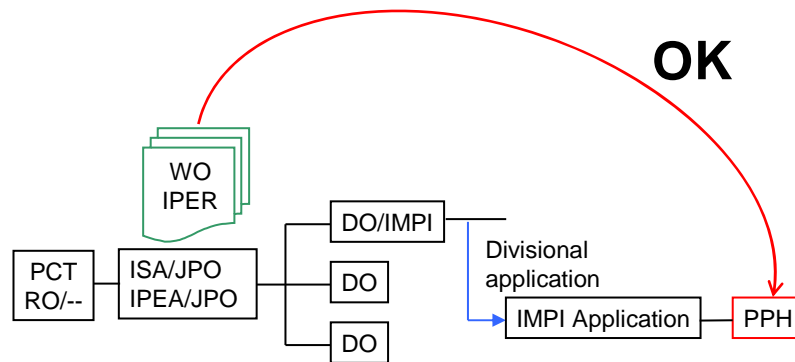

(E2) The application is an application claiming domestic priority from an application which satisfies the requirement (B).

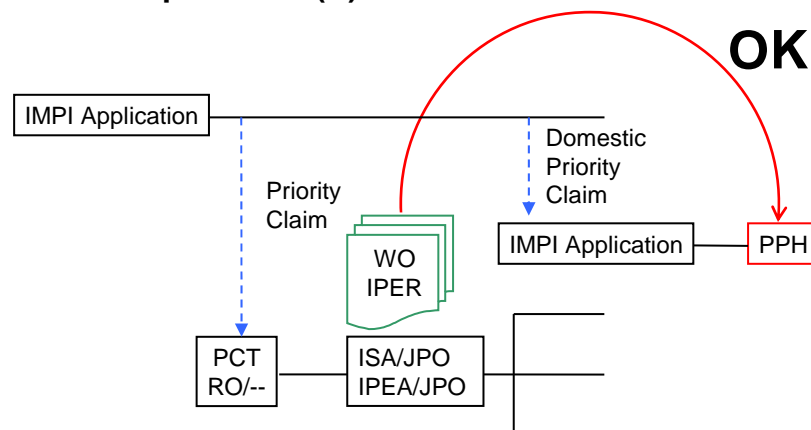

(F) A case not meeting requirement 1 (4)

