

**Revised Requirements for Requesting Participation in the
Patent Prosecution Highway (PPH) Program in the
United States Patent and Trademark Office (USPTO) Under the PPH Program
between
the USPTO and the Japan Patent Office**

I. Background

The United States Patent and Trademark Office (USPTO) implemented a patent prosecution highway (PPH) program on a permanent basis with the Japan Patent Office (JPO) on January 4, 2008. See <http://www.uspto.gov/web/offices/com/sol/og/2008/week10/TOC.htm#ref14>.

In order to improve the PPH program and make it available to a wider range of applicants, the USPTO and JPO have agreed to revise the requirements for requesting participation in the PPH program. The revised requirements and the trial period are set forth below and supersede all prior PPH notices between the USPTO and JPO. The PCT-PPH pilot program is not affected by the current notice and remains available to the applicants under the existing guidelines. See <http://www.uspto.gov/web/offices/com/sol/og/2010/week08/TOC.htm#ref17>.

II. Trial Period for the PPH Program

The PPH program with the revised requirements will commence on July 15, 2011, for a period of one year ending on July 14, 2012. The revised requirements will apply to PPH requests filed in the USPTO on or after July 15, 2011 based on claims that have been determined allowable by JPO in a corresponding application filed in JPO. The trial period may be extended for up to an additional year if necessary to adequately assess the feasibility of the PPH program. The USPTO and JPO will evaluate the results of the PPH program to determine whether and how the program should be implemented after the trial period. The Offices may also terminate the PPH program early if the volume of participation exceeds a manageable level, or for any other reason. Notice will be published if the PPH program will be terminated before the July 14, 2012 date.

III. Revised Requirements for Requesting Participation in the PPH Program in the USPTO

In order to be eligible to participate in the PPH program in the USPTO, the following conditions must be met:

(1) The U.S. application for which participation in the PPH program is requested and the corresponding JPO application must have the same priority/filing date. In particular, the U.S. application (including national stage entry of a PCT application and a so-called bypass application filed under 35 U.S.C. § 111(a) which validly claims benefit under 35 U.S.C. § 120 to a PCT application):

(Case I) – is an application that validly claims priority under 35 U.S.C. § 119(a) and 37 CFR 1.55 to one or more applications filed with JPO (examples are provided in the ANNEX, Figures A, B, C and D),

or

(Case II) – is an application which is the basis of a valid priority claim under the Paris Convention for the application filed in JPO (examples are provided in the ANNEX, Figures E, F and G),

or

(Case III) – is an application which shares a common priority document with the application filed in JPO (examples are provided in the ANNEX, Figures H, I, J, K, L, M and N),

or

(Case IV) – and the JPO application are derived from/related to a PCT application having no priority claim (examples are provided in the ANNEX, Figure O).

Provisional applications, plant applications, design applications, reissue applications, reexamination proceedings, and applications subject to a secrecy order are excluded and not subject to participation in the PPH.

(2) At least one claim was determined by JPO to be allowable/patentable. The applicant must submit a copy of the allowable/patentable claims from the JPO application along with an English translation thereof and a statement that the English translation is accurate if the claims are not in the English language. If the JPO office action does not explicitly state that a particular claim is allowable, the applicant must include a statement in the request for participation in the PPH program or in the transmittal letter accompanying the request for participation that no rejection has been made in the JPO office action regarding that claim, and therefore, the claim is deemed allowable by JPO.

(3) All claims on file, as originally filed or as amended, for examination under the PPH must sufficiently correspond to one or more of those claims indicated as allowable in the JPO. Claims are considered to "sufficiently correspond" where, accounting for differences due to translations and claim format, the claims in the USPTO are of the same or similar scope as the claims in the JPO, or the claims in the USPTO are narrower in scope than the claims in the JPO. In this regard, a claim that is narrower in scope occurs when a JPO claim is amended to be further limited by an additional feature that is supported in the specification (description and/or claims). A claim in the USPTO which introduces a new/different category of claims to those claims indicated as allowable in the JPO is not considered to sufficiently correspond. For example, if the JPO claims only

contain claims to a process of manufacturing a product, then the claims in the USPTO are not considered to sufficiently correspond if the USPTO claims introduce product claims that are dependent on the corresponding process claims.

The additional limitation that makes the claims in the U.S. application narrower in scope than the allowable/patentable claims in the JPO application must have support in the written description of the U.S. application and the additional limitation must be presented in dependent form. The applicant is required to submit a claims correspondence table in English. The claims correspondence table must indicate how all the claims in the U.S. application correspond to the allowable/patentable claims in the JPO application(s). The dependent claims with the additional limitations must be clearly identified in the claims correspondence table.

(4) Examination of the U.S. application for which participation in the PPH program is requested has not begun.

(5) The applicant must file a request for participation in the PPH program and a request that the U.S. application be advanced out of turn for examination by order of the Director to expedite the business of the Office under 37 CFR 1.102(a). A revised request form (PTO/SB/20JP) will be available from the USPTO Web site at <http://www.uspto.gov> on July 15, 2011. Applicants are encouraged to use the USPTO request form. A petition fee under 37 CFR 1.17(h) is NOT required. See Notice Regarding the Elimination of the Fee for Petitions To Make Special Filed Under the Patent Prosecution Highway (PPH) Programs, 75 Fed. Reg. 29312 (May 25, 2010).

(6) The applicant must submit a copy of the office action from the JPO application just prior to the “Decision to Grant a Patent” (e.g., the latest “Notification of Reasons for Refusal”) from each of the JPO application(s) containing the allowable/patentable claims that are the basis for the request, along with an English translation thereof and a statement that the English translation is accurate if the office actions are not in the English language. It will not be necessary for applicant to submit a copy of the “Decision to Grant a Patent” and an English translation thereof. If the JPO application is a first action allowance, i.e., there is no office action just prior to the “Decision to Grant a Patent,” then applicant should indicate on the request form that no office action from the JPO application is submitted since the JPO application was a first action allowance.

The applicant must submit copies of any office actions (which are relevant to patentability) from the JPO application(s) issued after the grant of the request for participation in the PPH program in the USPTO (especially where JPO might have reversed a prior holding of allowability).

(7) The applicant must submit an information disclosure statement (IDS) listing the documents cited by the JPO examiner in the JPO office action (unless such an IDS has already been filed in the U.S. application). The applicant must submit copies of all the documents cited in the JPO office action (unless the copies have already been filed in the U.S. application) except U.S. patents or U.S. patent application publications.

The request for participation in the PPH program and all the supporting documents must be submitted to the USPTO via EFS-Web and indexed with the following document description: "Petition to make special under Patent Pros Hwy." Information regarding EFS-Web is available at http://www.uspto.gov/ebc/efs_help.html. Any preliminary amendments and IDS submitted with the PPH documents must be separately indexed as a preliminary amendment and IDS, respectively.

Where the request for participation in the PPH program and special status are granted, the applicant will be notified and the U.S. application will be advanced out of turn for examination. In those instances where the request for participation in the PPH program does not meet all the requirements set forth above, the applicant will be notified and the defects in the request will be identified. The applicant will be given one opportunity to perfect the request in a renewed request for participation (which must be submitted via EFS-Web and indexed accordingly as noted above). Note that action on the application by the examiner will NOT be suspended (37 CFR 1.103) awaiting a reply by the applicant to perfect the request in a renewed request for participation. That is, if the application is picked up for examination by the examiner after the applicant has been notified of the defects in the request, any renewed request will be dismissed. If the renewed request is perfected and examination has not begun, the request and special status will be granted, the applicant will be notified and the U.S. application will be advanced out of turn for examination. If not perfected, the applicant will be notified and the application will await action in its regular turn.

(8) Request for participation in the PPH program and special status granted in a parent application will not carry over to a continuing application. The applicant must fulfill all the conditions set forth above in order for special status to be granted in the continuing application.

If any of the documents identified in items (2), (6) and (7) above have already been filed in the U.S. application prior to the request for participation in the PPH program, it will not be necessary for the applicant to resubmit these documents with the request for participation. The applicant may simply refer to these documents and indicate in the request for participation in the PPH program when these documents were previously filed in the U.S. application.

IV. Special Examining Procedures

Once the request for participation in the PPH program and special status have been granted to the U.S. application, the U.S. application will be taken up for examination by the U.S. examiner before all other categories of applications except those clearly in condition for allowance, those with set time limits, such as examiner's answers, and those that have been granted special status for "accelerated examination."

Any claims amended or added after the grant of the request for participation in the PPH program must sufficiently correspond to one or more allowable/patentable claims in the

JPO application(s). The applicant is required to submit a claims correspondence table along with the amendment (see III.(3) above). If the amended or newly added claims do not sufficiently correspond to the allowable/patentable claims in the JPO application(s), the amendment will not be entered and will be treated as a non-responsive reply.

The PPH program does not absolve applicants of all their duties under 37 CFR 1.56 and 37 CFR 11.18. By complying with requirements III.(6) and (7) identified above, applicants would be considered to have complied with their duties to bring to the attention of the USPTO any material prior art cited in the corresponding foreign application(s) (see MPEP § 2001.06(a)). Applicants still have a duty of candor and good faith, including providing to the USPTO other information known to them to be material to patentability.

Any inquiries concerning this notice may be directed to Magdalen Greenlief, Office of the Associate Commissioner for Patent Examination Policy, at 571-272-8140 or at magdalen.greenlief@uspto.gov.

Date: _____

David J. Kappos
Under Secretary of Commerce for Intellectual Property and
Director of the United States Patent and Trademark Office

ANNEX

A

(Case I)
- Paris route -

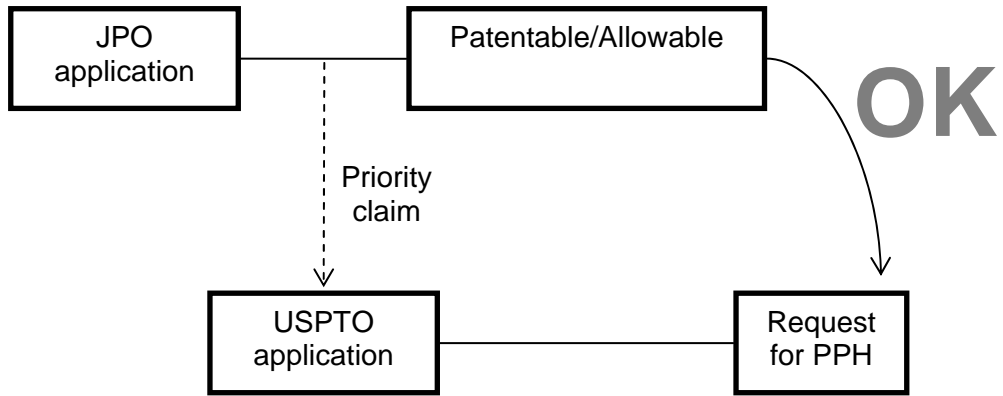

B

(Case I)
- PCT route -

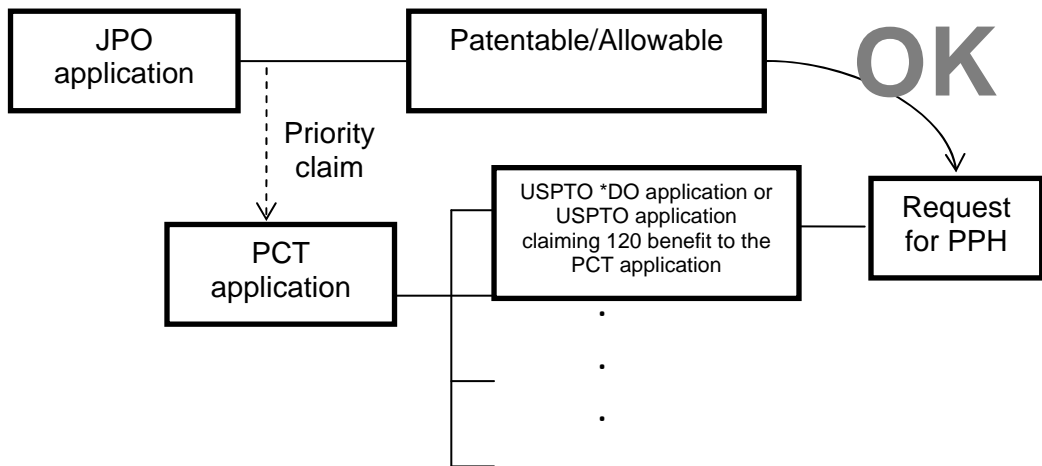

*DO – designated office

C

(Case I)
- Paris route & Complex priority -

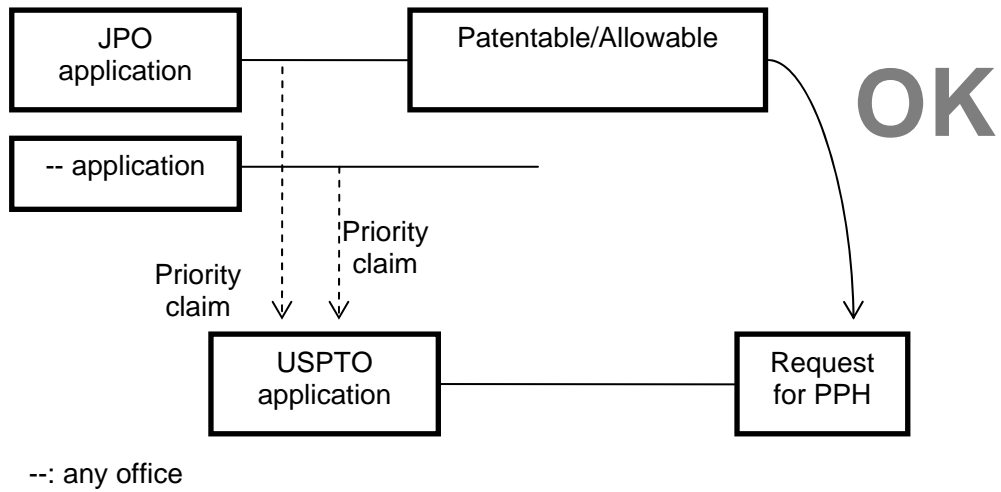

D

(Case I)
- Paris route & continuing application -

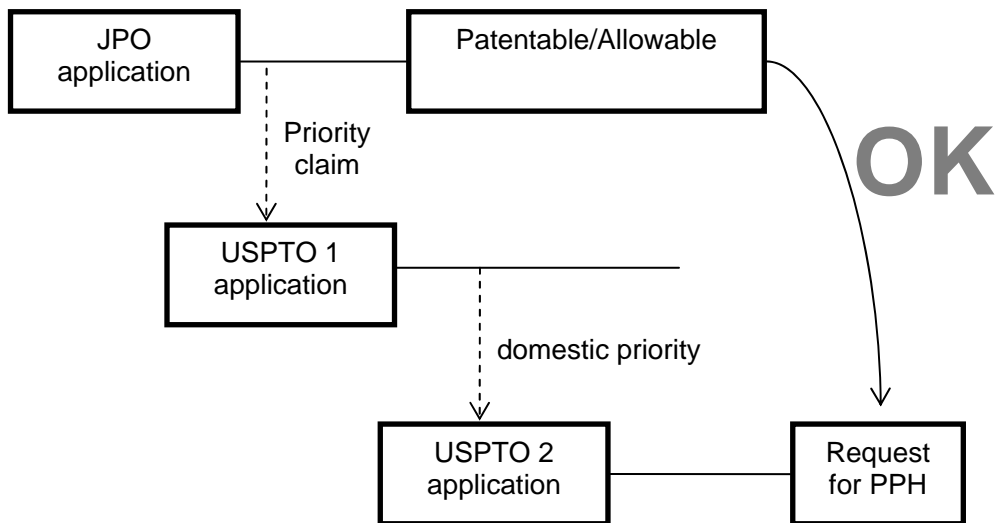

E

(Case II)
- Paris route -

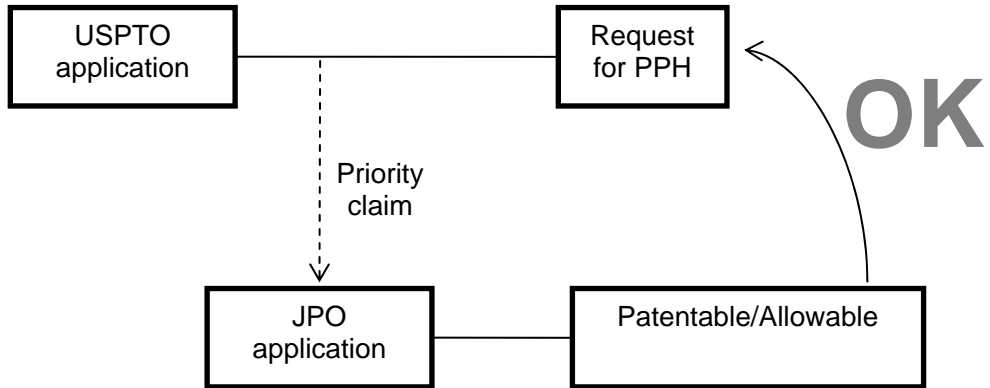

F

(Case II)
- PCT route -

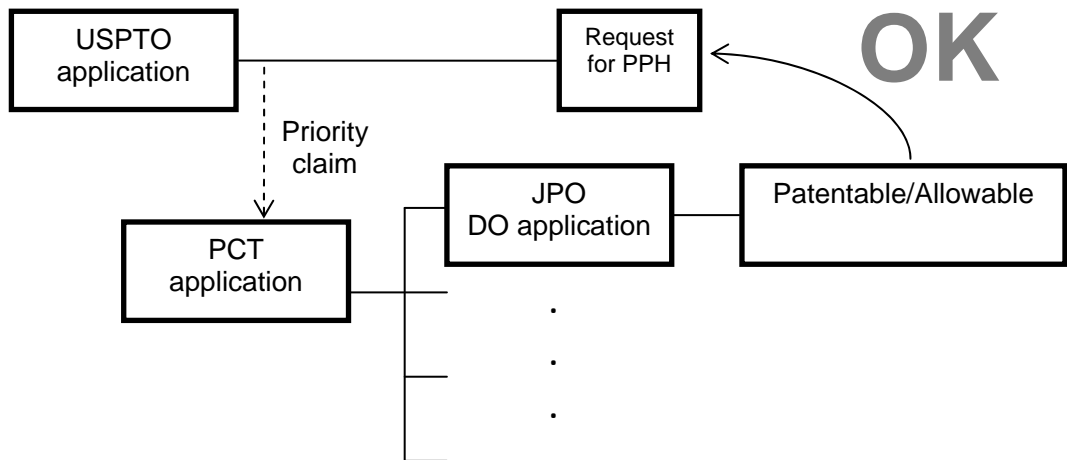

G

(Case II)
- Paris route & Complex priority -

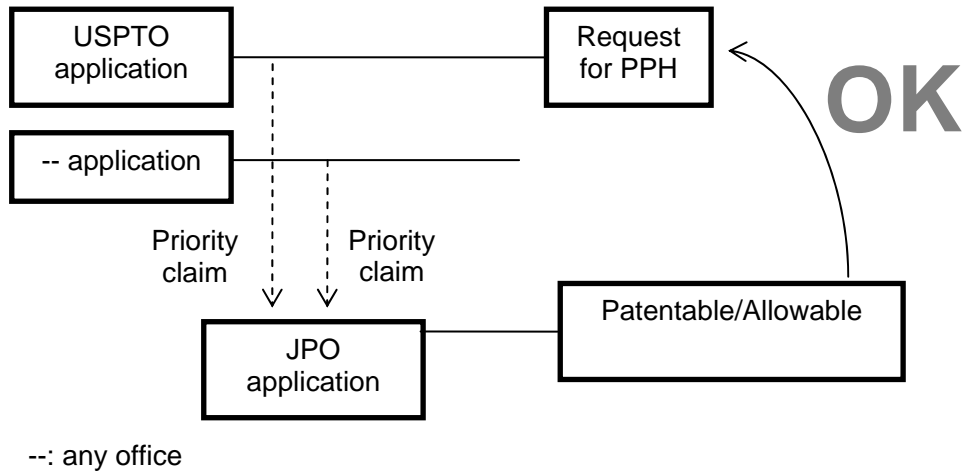

H

(Case III)
- Paris route, Domestic priority -

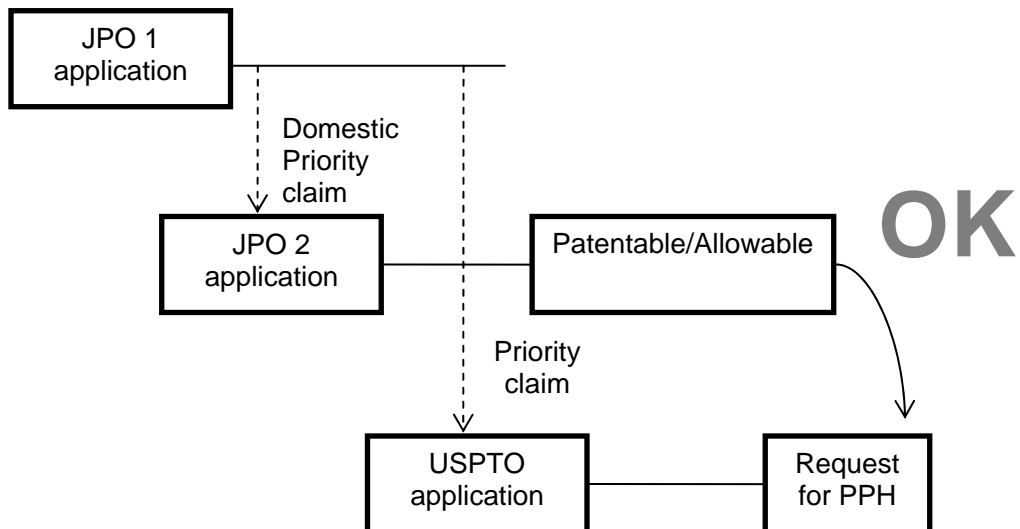

(Case III)

- Paris route, but the first application is from the third country -

I

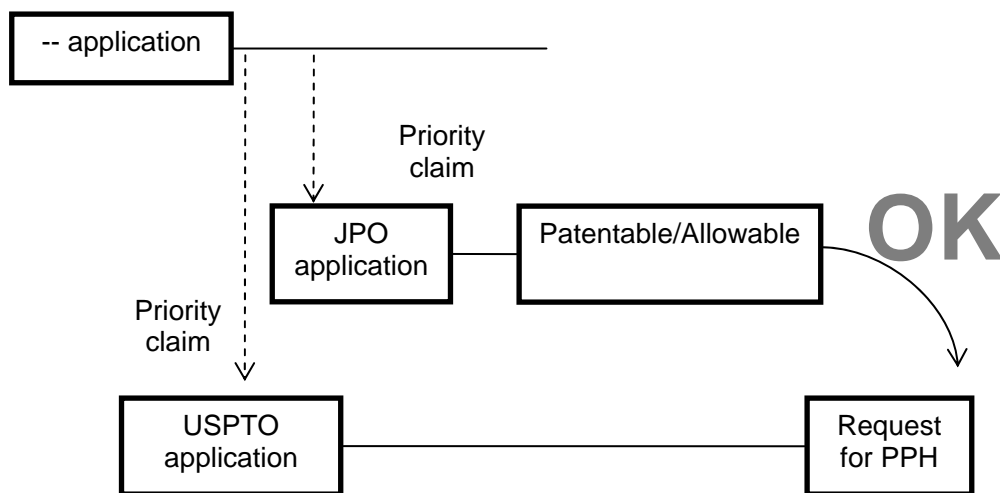

--: an office other than the JPO and the USPTO

(Case III)

- PCT route, but the first application is from the third country -

J

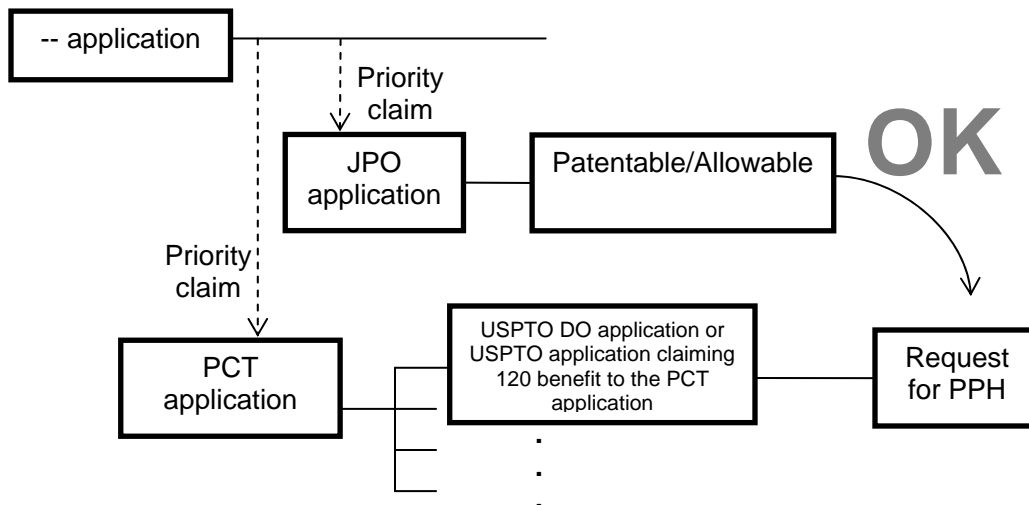

--: an office other than the JPO and the USPTO

(K)

(Case III)
- PCT route -

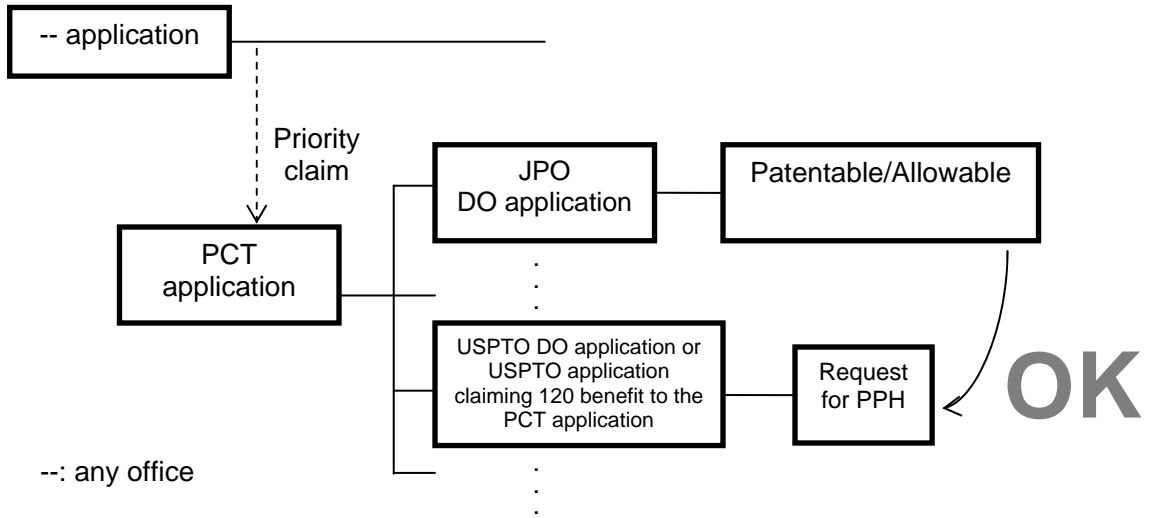

(L)

(Case III)
- Direct PCT & PCT route -

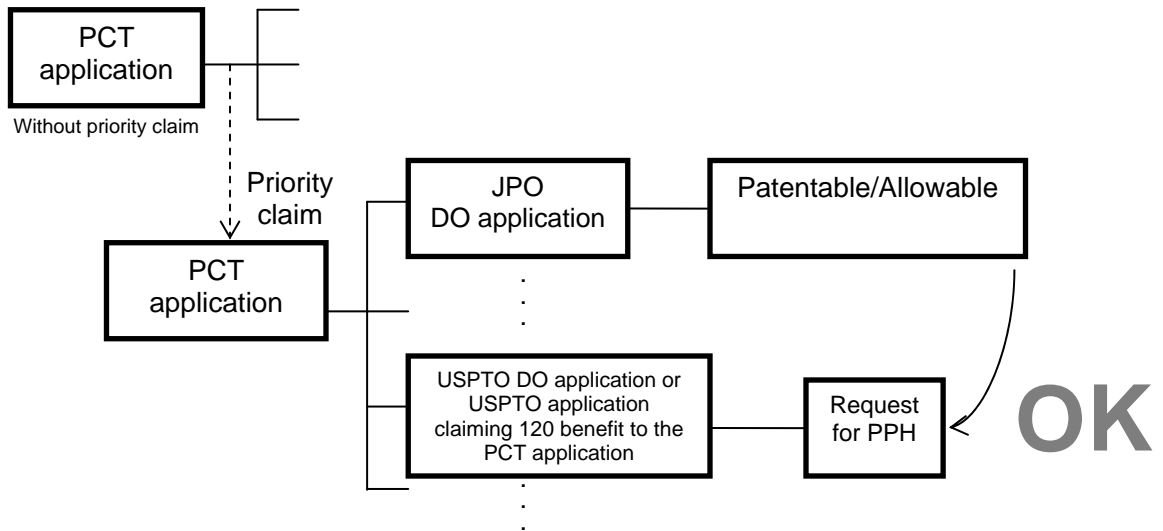

(M)

(Case III)
- Paris route & U.S. provisional application -

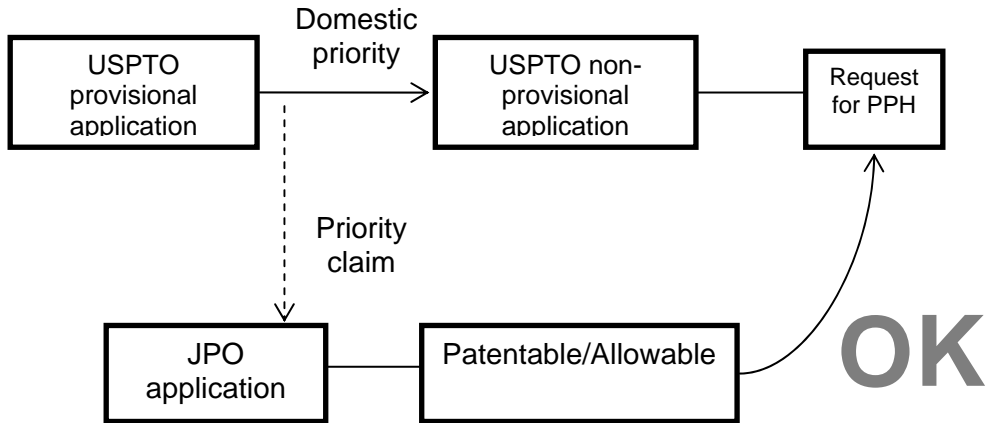

(N)

(Case III)
- PCT route & U.S. provisional application -

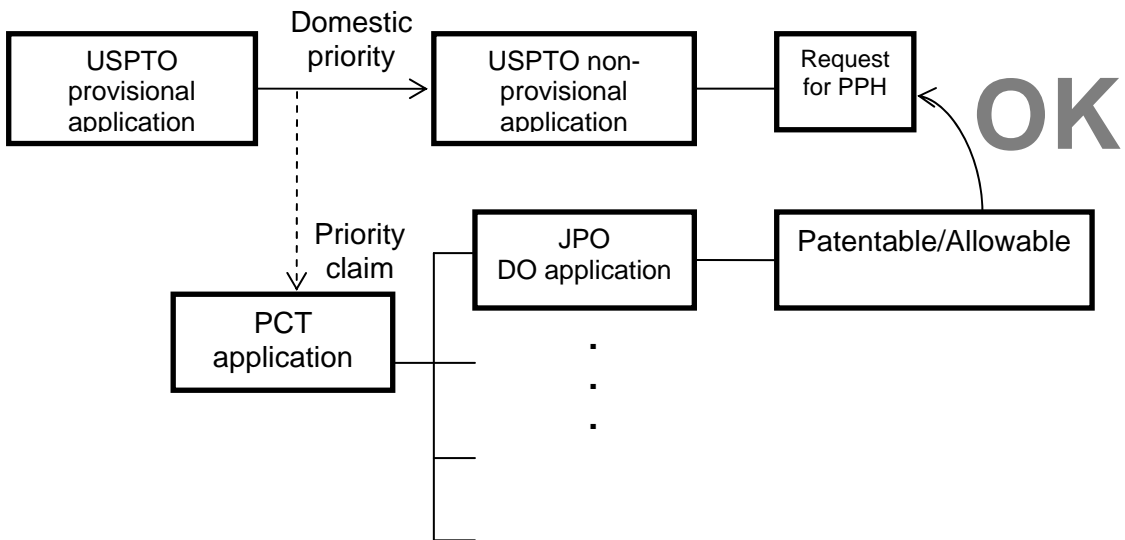

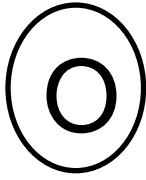

(Case IV)
- Direct PCT route -

