

Procedures to file a request to the JPO for Patent Prosecution Highway Pilot Program between the JPO and the EPO

Part I

PPH based on the European patent application

When an applicant files a request for an accelerated examination under the Patent Prosecution Highway (hereinafter called “PPH”) Pilot Program based on the European application to the JPO, an applicant must submit a request form “The Explanation of Circumstances Concerning Accelerated Examination” based on the procedure prescribed in “the Guidelines of the Accelerated Examination and Appeal.”¹

Under the PPH Pilot Program, an applicant is not required to fill in the section “2. the disclosure of prior arts and comparison between the claimed invention and prior art” in “The Explanation of Circumstances Concerning Accelerated Examination”.

The trial period of this PPH Pilot Program will commence on January 29, 2012, for a trial period duration of two years and ending on January 28, 2014.

The trial period may be extended if necessary until the EPO and the JPO receive the sufficient number of PPH requests to adequately assess the feasibility of the PPH program.

The Offices may also terminate the PPH pilot program early if the volume of participation exceeds manageable level, or for any other reason. Notice will be published if the PPH pilot program is terminated before 28 January 2014.

1. Requirements

(a) Both the JP application on which PPH is requested and the EP application(s) forming the basis of the PPH request shall have the same earliest date (whether this be a priority date or a filing date). For example, the JP application (including PCT national phase application) is either:

(Case I) an application which validly claims priority under the Paris Convention to the EP application(s) (examples are provided in ANNEX I, Figures

¹ http://www.jpo.go.jp/torikumi/t_torikumi/souki/pdf/v3souki/guideline.pdf

A, B, C, D and E), or

(Case II) an application which is the basis of a valid priority claim under the Paris Convention for the EP application(s) (including PCT national phase application(s)) (examples are provided in ANNEX I, Figures F, G and H), or

(Case III) an application which shares a common priority document with the EP application(s) (including PCT national phase application(s)) (examples are provided in ANNEX I, Figures I, J, K, L and M), or

(Case IV) a PCT national phase application where both the JP application and the EP application(s) are derived from a common PCT international application having no priority claim (examples are provided in ANNEX I, Figure N),

(b) At least one corresponding application exists in the EPO and has one or more claims that are indicated to be allowable/patentable in the latest office action by the EPO.

Claims are “determined to be allowable/patentable” in either of the following cases:

- (i) a communication regarding the intention to grant a European patent was issued on the claims (The heading of the communication is “Communication under Rule 71(3) EPC”)
- (ii) if the communication under (i) has not been issued yet, a positive opinion regarding the allowability of the claims is contained in the European Search Report (see Figure (E) in Annex I), i.e. neither category X documents (including category PX, EX and OX documents) nor category Y documents (including category PY, EY and OY documents) are cited as to the claims.

(c) All claims on file, as originally filed or as amended, for examination under the PPH must sufficiently correspond to one or more of those claims indicated as patentable/allowable in the EPO.

Claims are considered to “sufficiently correspond” where, accounting for differences due to translations and claim format, the claims in the JPO are of the same or similar scope as the claims indicated as patentable/allowable in

the EPO, or the claims in the JPO are narrower in scope than the claims indicated as patentable/allowable in the EPO. In this regard, a claim that is narrower in scope occurs when a claim indicated as patentable/allowable in the EPO is amended to be further limited by an additional technical feature that is supported in the specification (description and/or claims). A claim in the JPO which introduces a new/different category of claims to those claims determined to be patentable/allowable in the EPO is not considered to sufficiently correspond. For example, the claims indicated as patentable/allowable in the EPO only contain claims to a process of manufacturing a product, then the claims in the JPO are not considered to sufficiently correspond if the claims in the JPO introduce product claims that are dependent on the corresponding process claims.

(d) The JPO has not begun examination of the application. (an example is provided in ANNEX I, Figure O)

2. Documents to be submitted

Documents (a) to (d) below must be submitted by attaching to “The Explanation of Circumstances Concerning Accelerated Examination”.

Some of the documents may not be required to submit in certain cases. Please note that the name of the documents omitted to submit still have to be listed in “The Explanation of Circumstances Concerning Accelerated Examination” (Please refer to the **Example form** for the detail).

(a) A copy of all office actions which are relevant to allowability from the EPO, which were sent in regard to the corresponding EPO patent application, and their Japanese or English translations if they are not in English.

The EPO office actions which are relevant to allowability mean all issued “European Search Report”, “European Search Opinion”, “Examination Report” and “Communication under Rule 71(3) EPC”.

If these documents are written in English and available via the EPO dossier access system, i.e. epoline (registered trademark) (<https://register.epoline.org/espacenet/regviewer>), the applicant does not have to submit their copies and only have to list up the name of the

documents as “documents to be omitted to submit” in the request form “The Explanation of Circumstances Concerning Accelerated Examination”. If these documents are written in French or German, the applicant does not have to submit their copies if they are available via the EPO dossier access system, but has to attach their translations by him/herself.

(b) A copy of all claims determined to be allowable by the EPO, and their Japanese or English translations if they are not in English.

Copies of the claims determined to be allowable in the EPO can be a copy of the written amendments which include claims determined to be allowable, the documents submitted at filing which include claims determined to be allowable, the printer's copy (“Druckexemplar”) or the EPO’s publication of the granted patent.

The conditions where the applicant will not have to submit a copy and translation of the claims are the same as those that apply to the office actions as described above.

(c) Copies of documents cited by the EPO examiner

The copies of documents to be submitted are those cited in the “Examination Report” or, if no Examination Report has been issued, those listed in the “European Search Report”.

If a cited document is a patent document, the applicant does not have to submit it. In case the JPO has difficulty in obtaining the document, however, the applicant may be asked to submit it.

If a cited document is non-patent literature, the applicant always has to submit it.

Translations of cited documents are unnecessary.

(d) A claims correspondence table

The applicant must submit a claim correspondence table, which indicates how all claims in the JP application sufficiently correspond to the claims determined to be allowable by the EPO.

When claims are just literal translation, the applicant can just write down that “they are the same” in the table. When claims are not just literal translation, it is necessary to explain the sufficient correspondence of each claim based on the criteria 1. (c) (Please refer to the **Example form** below).

When the applicant has already submitted above documents (a) to (d) to the JPO through simultaneous or past procedures, the applicant may incorporate the documents by reference and will not have to attach them.

3. Example of “The Explanation of Circumstances Concerning Accelerated Examination” for filing request an accelerated examination under the PPH pilot program

(1) Circumstances

Please state that an accelerated examination is requested under the PPH pilot program, explaining that the relationship between the application requested for the PPH and the corresponding EP application(s) meets the requirement under 1. (a) and that the corresponding EP application(s) meets either (i) or (ii) of 1. (b). The application number(s) of the corresponding EP application(s) must be specified. If the application requested for the PPH or the corresponding EP application(s) is a derived application (e.g., the EP application that is determined to be allowable is a divisional application of an EP application which forms the basis of the priority claim of the JP application), please indicate the application number of its basic application.

(2) Documents to be submitted

The applicant must list all required documents mentioned above 2. in an identifiable way, even when applicant omits to submit certain documents.

(3) Notice

Forms of “The Explanation of Circumstances Concerning Accelerated Examination” are different between on-line procedure and paper procedure. Please refer to the examples of forms when filling in (“Form 1 for Accelerated Examination” for on-line procedures, and “Form 2 for Accelerated Examination” for paper procedures.).

Example Form for the on-line PPH filing procedure

<p>【書類名】 早期審査に関する事情説明書 The name of this paper</p>	
<p>【提出日】 平成00年00月00日 Date of filing</p>	
<p>【あて先】 特許庁長官殿 Destination</p>	
<p>【事件の表示】 【出願番号】 特願 0000-000000 Application number</p>	
<p>【提出者】 【識別番号】 000000000 【住所又は居所】 〇〇県〇〇市〇丁目 【氏名又は名称】 〇〇〇〇〇 The name and address of the submitter</p>	
<p>【代理人】 【識別番号】 000000000 【住所又は居所】 〇〇県〇〇市〇丁目 【氏名又は名称】 〇〇 〇〇 The name and address of the attorney</p>	
<p>【早期審査に関する事情説明】 The explanation of circumstances concerning accelerated examination</p>	
<p>1. 事情 本出願と欧州特許庁への対応出願(特許出願番号0000000)は、共に、英国知的財産庁への一つの出願(出願番号00/000000)に対してパリ条約に基づく優先権を有効に主張する出願であり、日欧特許審査ハイウェイに基づく早期審査の申請を行うものである。 当該欧州出願に対して、**年**月**日付で特許許可通知(EPC規則71(3)に基づく通知)が発行されている。</p>	
<p>1, Circumstances Both this application and the corresponding EP application (the application number is 0000000) validly claim priority under the Paris Convention to a UKIPO application (the application number is 00/000000), and the accelerated examination is requested under the PPH pilot program between the JPO and the EPO. A communication under Rule 71(3) EPC is issued on (date) toward the corresponding EP patent application,</p>	
<p>(提出を省略する物件) (物件名) **年**月**日付の対応欧州出願に対する欧州調査報告(European Search Report)の写し (物件名) **年**月**日付の対応欧州出願に対する拒絶理由通知(Examination Report)の写し (物件名) **年**月**日付の対応欧州出願に対する欧州調査見解(European Search Opinion)</p>	

List up the documents which can be omitted to submit

の写し

(物件名) **年**月**日付の対応欧州出願に対する特許許可通知(EPC規則71(3)に基づく通知)の写し

(物件名) 対応欧州出願の特許公報である欧州特許第0000000号明細書

(物件名) 対応欧州出願に対して引用された米国特許第0000000号明細書

(物件名) 対応欧州出願に対して引用された欧州特許出願公開第0000000号明細書

(Documents to be omitted to submit)

(The name of the document) Copy of the European Search Report of (date)

(The name of the document) Copy of the European Search Opinion of (date)

(The name of the document) Copy of the Examination Report of (date)

(The name of the document) Copy of the communication under Rule 71(3) EPC of (date)

(The name of the document) Publication of the corresponding EP patent application:
EP 0000000 B1

(The name of the document) Cited reference of the corresponding EP patent application:
US 0000000 A

(The name of the document) Cited reference of the corresponding EP patent application:
EP 0000000 A1

以下において、「引用非特許文献1」とは、「村岡洋一著、「コンピュータサイエンス大学講座(第11巻)コンピュータ・アーキテクチャ」、第2版、株式会社近代科学者、1985年11月、p.123-127」である。

In what follows, “cited non-patent literature1” is “Yoichi Muraoka, Lecture of Computer Science (vol.11) computer architecture, 2nd edition, Scientist com, Nov. 1985, p.123-127.”

If the name of the document is long (over 50 letters), it is impossible to write it down directly to the column “【物件名】”. In this case, please write down the full name of the document in the column “【早期審査に関する事情説明】” and name it properly. Then write the name in the column “【物件名】”.

List up the documents to be submitted

【提出物件の目録】
The list of submitted documents

【物件名】 欧州出願と本出願の請求項の対応関係を示す書面 1
【物件名】 引用非特許文献1 1

(The name of the document) The table explaining how the claims indicated to be allowable by the EPO sufficiently correspond to the claims in the JP patent application 1
(The name of the document) Cited non-patent literature1 1

Use the same name as in“【物件名】” under “【提出物件の目録】.”

【添付物件】
The list of attached documents

【物件名】 欧州出願と本出願の請求項の対応関係を示す書面

The table explaining how the claims indicated to be allowable by the EPO sufficiently correspond to the claims in the JP application

【内容】

Attach the document here as image file or text.

本出願の 請求項 The claim filed to the JPO	欧州特許庁で特 許可能とされた 請求項 The claim indicated to be allowable in the EPO	対応関係に関するコメント Comments about the correspondence
1	1	両クレームは同一である。 Both claims are the same.
2	2	両クレームは、記載形式を除き同一である。 Both claims are the same except the claim format.
3	1	請求項3は、欧州特許出願の請求項1にAという発明特 定事項を付加したものである。 Claim 3 in the JP application adds composition A to claim 1 filed at the EPO

【物件名】 引用非特許文献1

Cited non-patent literature1

Use the same name as in “【物件名】” under “【提出物件の目録】.”

【内容】

Attach the copy of the document.

Please note that in the case of paper procedure, the pendency period (the period between the request for PPH and the first office action) tends to be longer than on-line procedure

Part II

PPH using the PCT international work products from the EPO

Applicants can request accelerated examination by a prescribed procedure including submission of relevant documents on an application which is filed with the Japan Patent Office (JPO) and satisfies the following requirements under the JPO-EPO Patent Prosecution Highway pilot programs based on PCT international work products (PCT-PPH pilot program).

When filing a request for the PCT-PPH pilot program, an applicant must submit a request form “The Explanation of Circumstances Concerning Accelerated Examination” based on the procedure prescribed in “the Guidelines of the Accelerated Examination and Appeal.”² Under the PCT-PPH Pilot program, an applicant is not required to fill in the section “2. the disclosure of prior arts and comparison between the claimed invention and prior art” in “The Explanation of Circumstances Concerning Accelerated Examination”.

The trial period of the PCT-PPH pilot program will commence on January 29, 2012, for a trial period duration of two years and ending on January 28, 2014.

The trial period may be extended if necessary until the JPO and EPO receive the sufficient number of PCT-PPH requests to adequately assess the feasibility of the PCT-PPH pilot program.

The Offices may also terminate the PCT-PPH pilot program early if the volume of participation exceeds manageable level, or for any other reason. Notice will be published if the PCT-PPH pilot program is terminated before 28 January 2014.

1. Requirements

The application which is filed with the JPO and on which the applicant files a request under the PCT-PPH must satisfy the following requirements:

- (1) The latest work product in the international phase of a PCT application corresponding to the application (“international work product”), namely the Written Opinion of International Search Authority (WO/ISA), the Written Opinion of International Preliminary Examination Authority (WO/IPEA) or the International Preliminary Examination Report (IPER), indicates at least one claim as allowable (from the aspect of novelty, inventive steps and industrial applicability).

² http://www.jpo.go.jp/torikumi/t_torikumi/souki/pdf/v3souki/guideline.pdf

Note that the ISA and the IPEA which produced the WO/ISA, WO/IPEA and the IPER are limited to the EPO, but, if priority is claimed, the priority claim can be to an application in any Office, see example A' in Annex II (application ZZ can be any national application).

The applicant cannot file a request under PCT-PPH on the basis of an International Search Report (ISR) only.

In case any observation is described in Box VIII of WO/ISA, WO/IPEA or IPER which forms the basis of a PCT-PPH request, the applicant must identify and explain which claim(s) is/are allowable whether or not an amendment is submitted to correct the observation noted in Box VIII. The application will not be eligible for participating in PCT-PPH pilot program if the applicant does not identify and explain which claim(s) is/are allowable. In this regard, however, it does not affect the decision on the eligibility of the application whether the explanation is adequate and/or whether the amendment submitted overcomes the observation noted in Box VIII.

- (2) The relationship between the application and the corresponding international application satisfies one of the following requirements:
 - (A) The application is a national phase application of the corresponding international application. (See Diagrams A, A', and A'' in Annex II)
 - (B) The application is a national application as a basis of the priority claim of the corresponding international application. (See Diagram B in Annex II)
 - (C) The application is a national phase application of an international application claiming priority from the corresponding international application. (See Diagram C in Annex II)
 - (D) The application is a national application claiming foreign/domestic priority from the corresponding international application. (See Diagram D in Annex II)
 - (E) The application is the derivative application (divisional application and application claiming domestic priority etc.) of the application which satisfies one of the above requirements (A) – (D). (See Diagrams E1 and E2 in Annex II)
- (3) All claims on file, as originally filed or as amended, for examination under the PCT-PPH must sufficiently correspond to one or more of those claims indicated as patentable/allowable in the EPO as ISA/IPEA.

Claims are considered to "sufficiently correspond" where, accounting for differences due to translations and claim format, the claims in the JPO are of the same or similar scope as the claims indicated as patentable/allowable in the EPO, or the claims in the JPO are narrower in scope than the claims indicated as patentable/allowable in the EPO.

In this regard, a claim that is narrower in scope occurs when a claim indicated as patentable/allowable in the EPO is amended to be further limited by an additional feature that is supported in the specification (description and/or claims) of the application.

A claim in the JPO which introduces a new/different category of claims to those claims indicated as patentable/allowable in the EPO is not considered to sufficiently correspond. For example, the claims indicated as patentable/allowable in the EPO only contain claims to a process of manufacturing a product, then the claims in the JPO are not considered to sufficiently correspond if the claims in the JPO introduce product claims that are dependent on the corresponding process claims.

- (4) The JPO has not begun examination of the application at the time of request under PCT-PPH.

2. Documents to be submitted

The applicant must submit the following documents attached to the request form in filing a request under PCT-PPH.

Some of the documents may not be required to submit in certain cases. Please note that the name of the documents omitted to submit still have to be listed in "The Explanation of Circumstances Concerning Accelerated Examination" (Please refer to the Example form for the detail).

- (1) A copy of the latest international work product which indicated the claims to be allowable and their Japanese or English translations if they are not in English.

In case the application satisfies the relationship I.(2)(A), the applicant need not submit a copy of the International Preliminary Report on Patentability (IPRP) and any English translations thereof because a copy of these documents is already contained in the file-wrapper of the application. In addition, if the copy of the latest international work product and the copy of the translation are

available via “PATENTSCOPE (registered trademark)”*, an applicant need not submit these documents, unless otherwise requested by the JPO.

(WO/ISA and IPER are usually available as “IPRP Chapter I” and “IPRP Chapter II” respectively in 30 months after the priority date.)

- (2) A copy of a set of claims which the latest international work product of the corresponding international application indicated to be allowable and their Japanese or English translations if they are not in English

If the copy of the set of claims which are indicated to be allowable is available via “PATENTSCOPE (registered trademark)” (e.g. the international Patent Gazette has been published), an applicant need not submit this document unless otherwise requested by the JPO. Where the set of claims is written in French or German, the translations must be submitted by an applicant.

- (3) A copy of references cited in the latest international work product of the international application corresponding to the application.

If the reference is a patent document, the applicant is not required to submit it. In case the JPO has difficulty in obtaining the document, however, the applicant may be asked to submit it. Non-patent literature must always be submitted. Translations of cited documents are unnecessary.

- (4) A claims correspondence table which indicates how all claims in the application sufficiently correspond to the claims indicated to be allowable.

When claims are just literal translation, the applicant can just write down that “they are the same” in the table. When claims are not just literal translation, it is necessary to explain the sufficient correspondence of each claim based on the criteria 1. (3) (Please refer to the **Example form** below).

When an applicant has already submitted the above mentioned documents (1) - (4) to the JPO through simultaneous or past procedures, the applicant may incorporate the documents by reference and is thus not required to attach the documents.

3. Example of “The Explanation of Circumstances Concerning Accelerated Examination” for filing request an accelerated examination under the

* <http://www.wipo.int/pctdb/en/index.jsp>

PCT-PPH pilot program

(1) Circumstances

The applicant must indicate that the application is included in (A) to (E) of 1. (2), and that the accelerated examination is requested under the PCT-PPH pilot program. The application number(s) of the corresponding international application(s) also must be written.

In case any observation is described in Box VIII of WO/ISA, WO/IPEA or IPER which forms the basis of a PCT-PPH request, the applicant must identify and explain which claim(s) is/are allowable.

(2) Documents to be submitted

The applicant must list all required documents mentioned above 2. in an identifiable way, even when applicant omits to submit certain documents.

(3) Notice

Forms of “The Explanation of Circumstances Concerning Accelerated Examination” are different between on-line procedure and paper procedure. Please refer to the examples of forms when filling in (“Form 1 for Accelerated Examination” for on-line procedures, and “Form 2 for Accelerated Examination” for paper procedures.).

Example form of on-line procedures

<p>【書類名】 早期審査に関する事情説明書 ----- The name of this paper</p>	
<p>【提出日】 平成00年00月00日 ----- Date of filing</p>	
<p>【あて先】 特許庁長官殿 ----- Destination</p>	
<p>【事件の表示】 【出願番号】 特願 0000-000000 ----- Application number</p>	
<p>【提出者】 【識別番号】 000000000 【住所又は居所】 〇〇県〇〇市〇丁目 【氏名又は名称】 〇〇〇〇 ----- The name and address of who submit this</p>	
<p>【代理人】 【識別番号】 000000000 【住所又は居所】 〇〇県〇〇市〇丁目 【氏名又は名称】 〇〇 〇〇 ----- The name and address of the attorney</p>	
<p>【早期審査に関する事情説明】 ----- The explanation of circumstances concerning accelerated examination</p>	
<p>1. 事情 本出願は国際出願(出願番号 PCT/EP0000/000000)の国内移行出願であり、特許審査ハイウェイに基づく早期審査の申請を行うものである。 当該国際出願について国際調査機関としての欧州特許庁が作成した見解書において、特許請求の範囲に対し特許可能との判断が明示されている。</p>	
<p>----- 1. Circumstances This application is a national phase application of a PCT international application (the application number is PCT/EP0000/000000), and the accelerated examination is requested under the PPH program. The WO/ISA issued by the EPO as an ISA indicates at least one claim to be allowable.</p>	
<p>(提出を省略する物件) (物件名)**年**月**日付の対応国際出願に対する WO/ISA の写し (物件名)対応国際出願の国際公開公報である国際公開第0000/000000号 (物件名)対応国際出願に対して引用された米国特許第000000号公報 (物件名)対応国際出願に対して引用された日本国特許第000000号公報</p>	

List up the documents which can be omitted to submit

(Documents to be omitted to submit)
(The name of the document) Copy of WO/ISA on (date)
(The name of the document) International publication of the corresponding PCT international application: WO 0000/000000
(The name of the document) Cited reference of the corresponding PCT international application: United States Publication of application 0000000
(The name of the document) Cited reference of the corresponding PCT international application: Japan Patent publication of application 0000000

以下において、「引用非特許文献1」とは、「村岡洋一著、「コンピュータサイエンス大学講座(第11巻)コンピュータ・アーキテクチャ」、第2版、株式会社近代科学者、1985年11月、p.123-127」である。

In what follows, “non-patent literature1” is “Yoichi Muraoka, Lecture of Computer Science (vol.11) computer architecture, 2nd edition, Scientist com, Nov. 1985, p.123-127.”

【提出物件の目録】

The list of submitted documents

【物件名】 国際出願と本出願の請求項の対応関係を示す書面 1

The table to explain how the claims indicated as allowable in the international phase sufficiently correspond to the claims in the JP application 1

【物件名】 引用非特許文献1 1

Non-patent literature1 1

List up the documents to be submitted

If the name of the document is long (over than 50 letters), it is impossible to write it down directly to the column “【物件名】.” Please write down the full name of the document in the column “【早期審査に関する事情説明】” and name it properly. Then write the name in the column “【物件名】.”

Use the same name as “【物件名】” under “【提出物件の目録】.”

Attach the document here as image file or text.

【添付物件】

The list of attached documents

【物件名】 国際出願と本出願の請求項の対応関係を示す書面

The table to explain how the claims indicated as allowable in the international phase sufficiently correspond to the claims in the JPO application

【内容】

本出願の請求項	国際段階で特許可能とされた請求項	対応関係に関するコメント
The claim in the JPO	The allowable claim in the international phase	Comments about the correspondence
1	1	両クレームは同一である。 Both claims are the same.
2	2	”
3	1	両クレームは、記載形式を除き同一である。 Both claims are the same except the claim format.
4	2	”
5	1	請求項 5 は、国際段階の請求項 1 に A という構成を付加したものである。 The claim 5 in the JPO has additional composition A on the Claim 1 in the international phase.

【物件名】 引用非特許文献1
 Non-patent literature1

【内容】

Attach the copy of the document.

Use the same name as “【物件名】” under “【提出物件の目録】.”

Note that in the case of paper procedure, the pendency period (the period between the request for PPH and the first office action) tends to be longer than on-line procedure.

A

(Case I)
- Paris route -

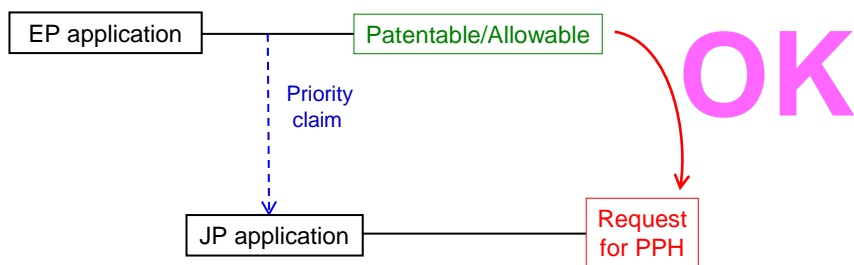

B

(Case I)
- PCT route -

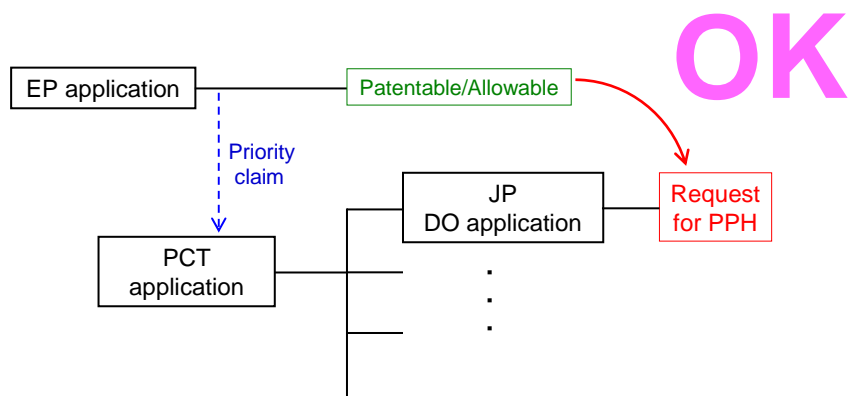

C

(Case I)
- Paris route & Complex priority -

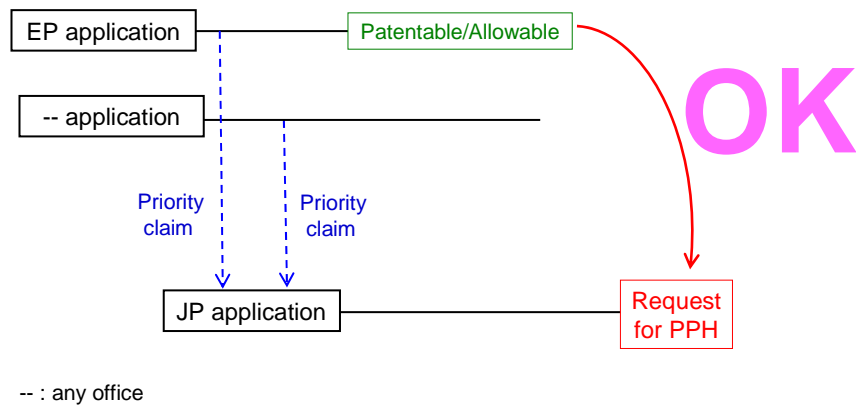

D

(Case I)
- Paris route & divisional application -

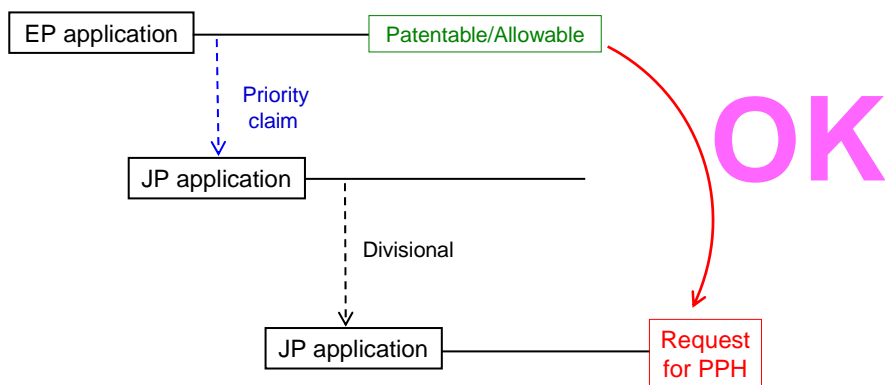

E

(Case I)
- Search Report -

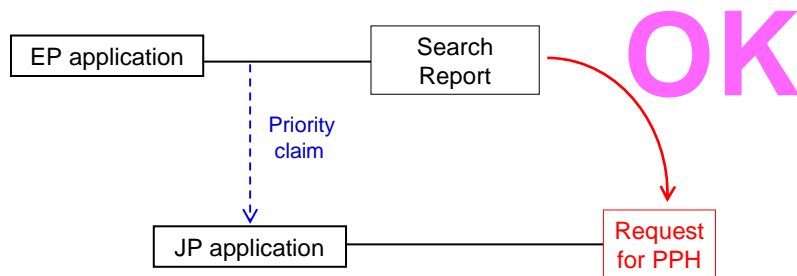
**F**

(Case II)
- Paris route -

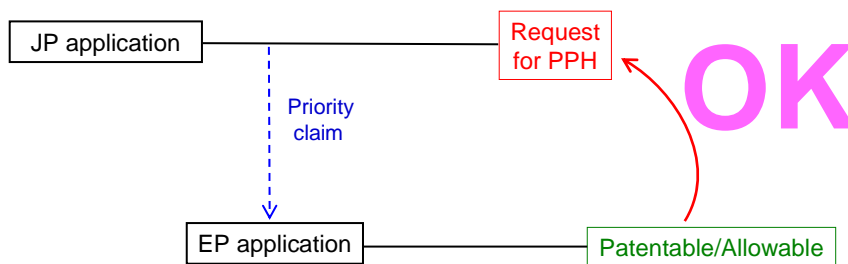

G

(Case II)
- PCT route -

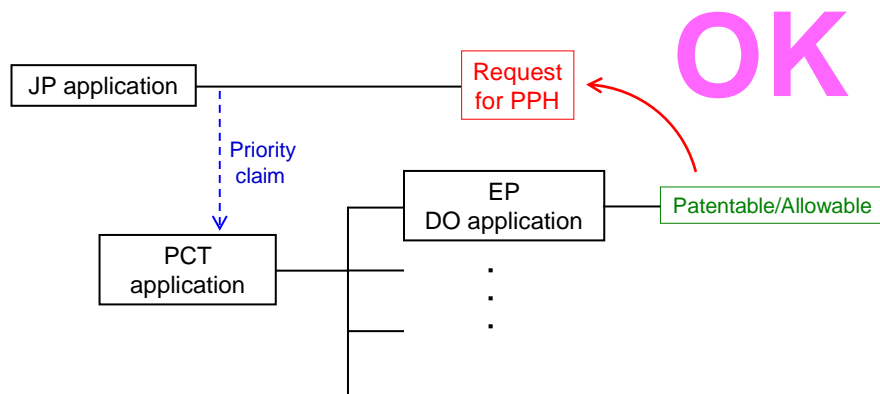

H

(Case II)
- Paris route & Complex priority -

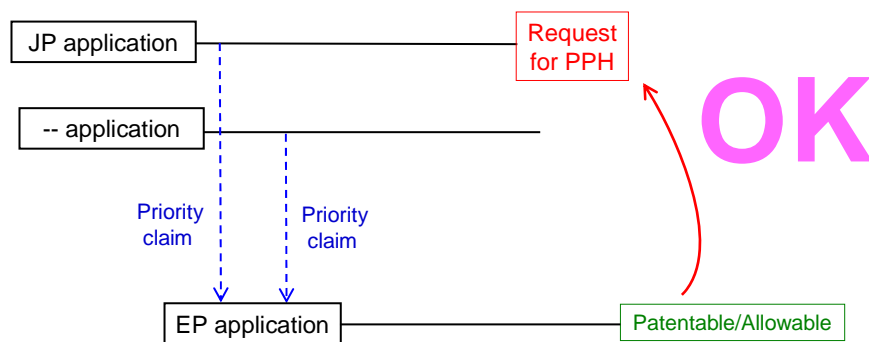

-- : any office

I

(Case III)
- Paris route, Internal priority -

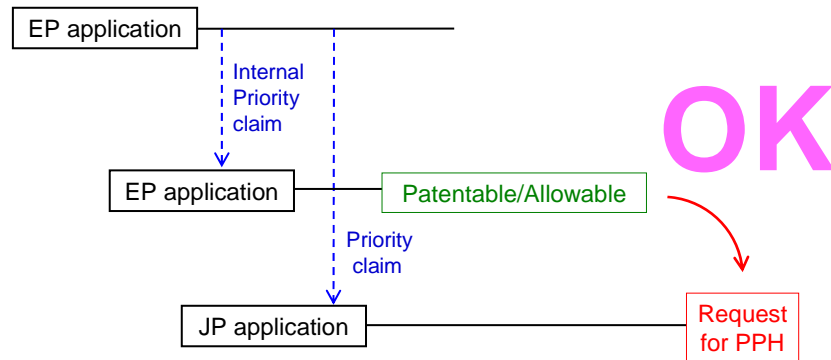

J

(Case III)
- Paris route, but the first application is from the third country -

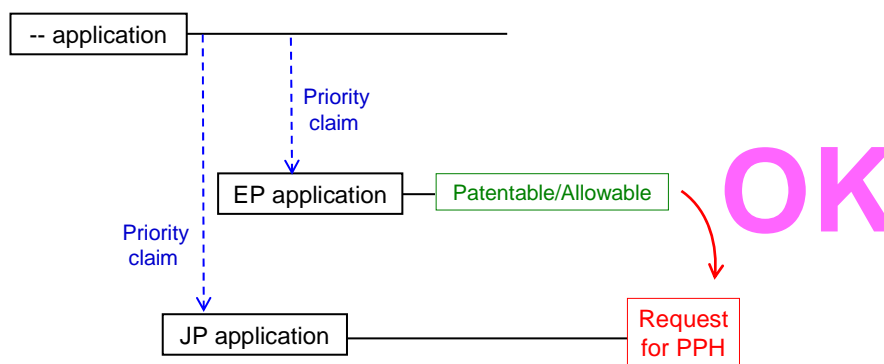

-- : the office other than the JPO and the EPO

K

(Case III)

- PCT route, but the first application is from the third country -

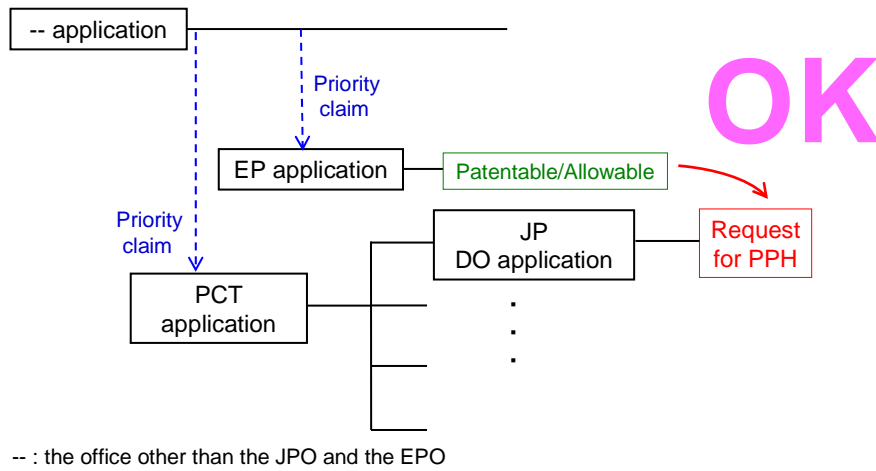

L

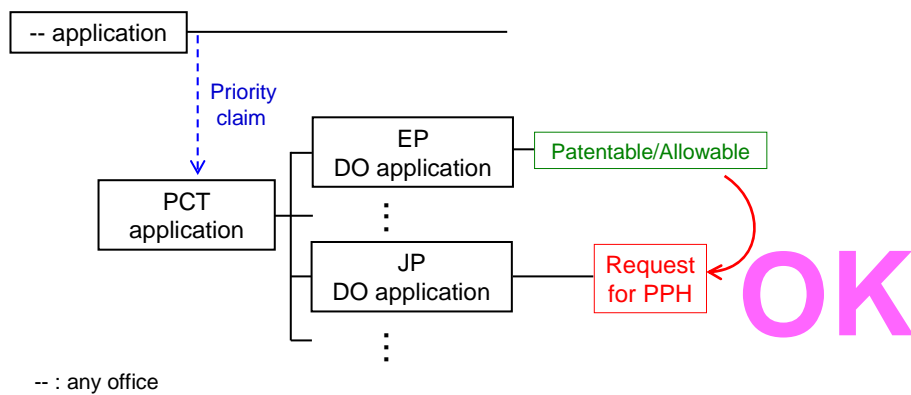
(Case III)
- PCT route -

M

(Case III)
- Direct PCT & PCT route -

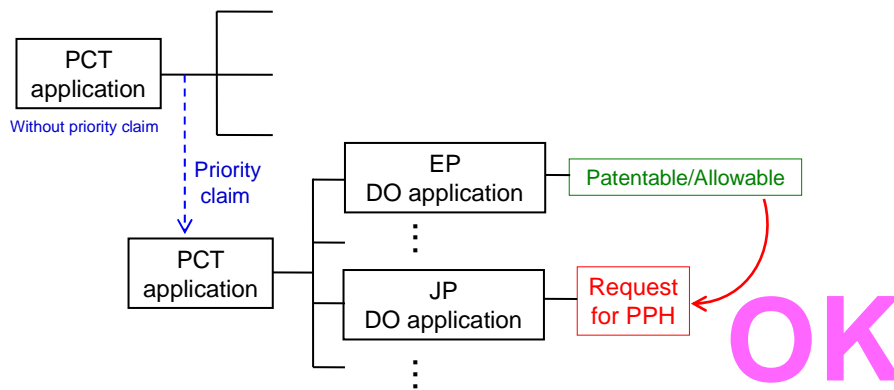

N

(Case IV)
- Direct PCT route -

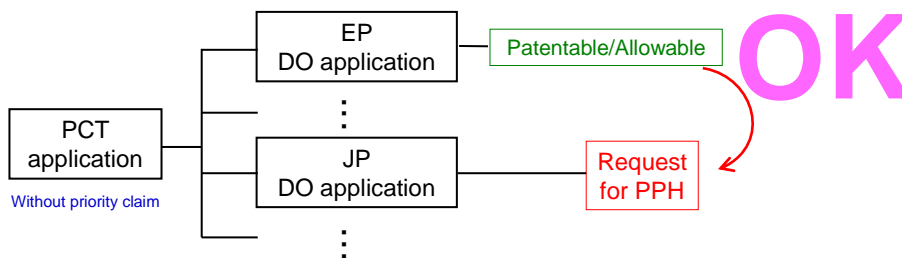

O A case not meeting requirement (d)
- Examination has begun before a request for PPH -

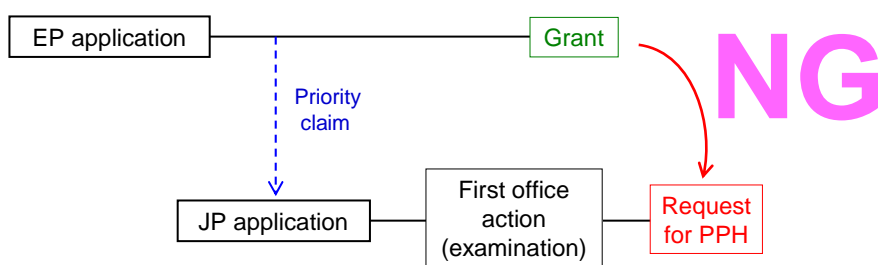

(A) The application is a national phase application of the corresponding international application.

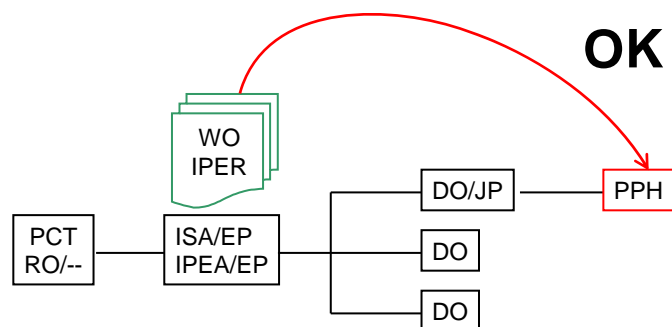

(A') The application is a national phase application of the corresponding international application.

(The corresponding international application claims priority from a national application.)

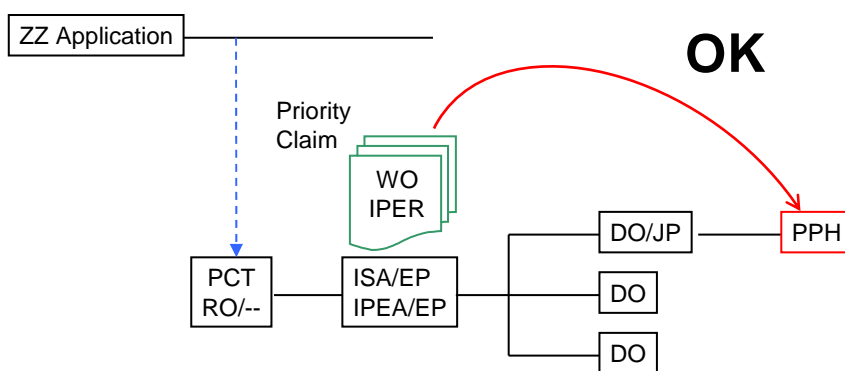

ZZ=any office

(A'') The application is a national phase application of the corresponding international application.

(The corresponding international application claims priority from an international application.)

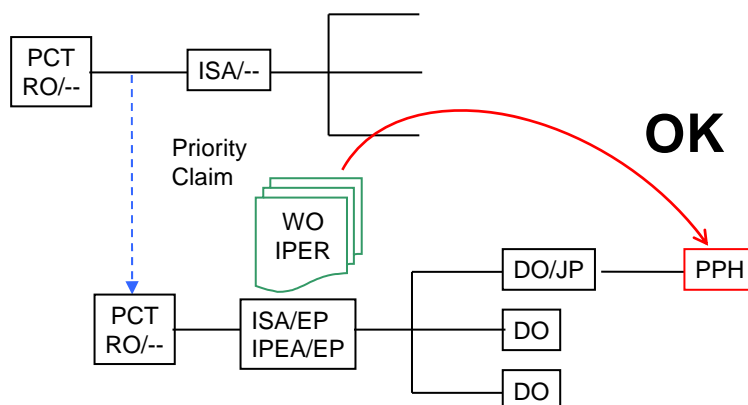

(B) The application is a national application as a basis of the priority claim of the corresponding international application.

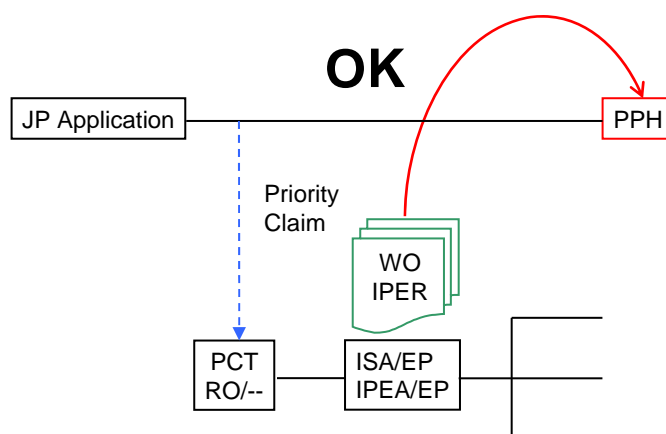

(C) The application is a national phase application of an international application claiming priority from the corresponding international application.

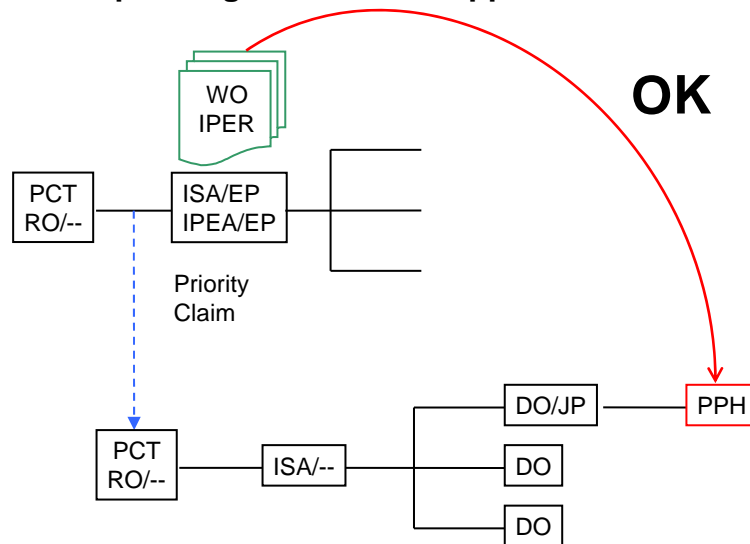

(D) The application is a national application claiming foreign/domestic priority from the corresponding international application.

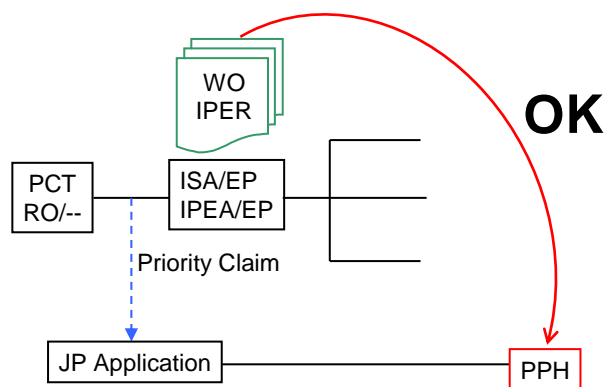

(E1) The application is a divisional application of an application which satisfies the requirement (A).

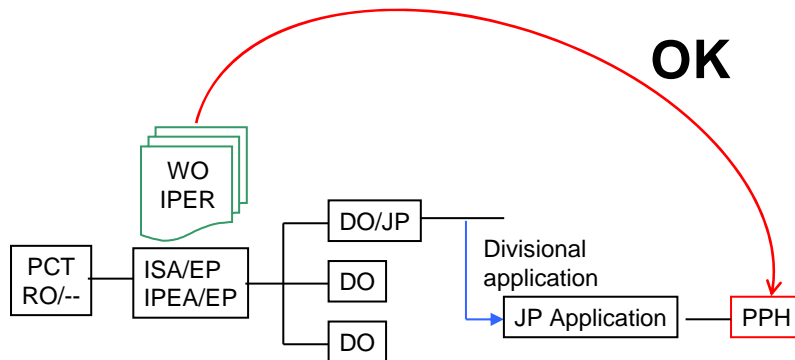

(E2) The application is an application claiming domestic priority from an application which satisfies the requirement (B).

