

# Outline of Japanese Patent Law

Japan Patent Office

Asia - Pacific Industrial Property Center, Japan Institute for

Promoting Invention and Innovation

©2018

Collaborator: Mr. Masayoshi SUMIDA  
Attorney at Law,  
Professor of Intellectual Property Law,  
Executive Director,  
Social Science Research Institute,  
Tokai University

# Outline of Japanese Patent Law

Mr. Masayoshi SUMIDA

Attorney at Law, Professor of Intellectual Property Law, Executive Director,  
Social Science Research Institute, Tokai University

## Table of Contents

1. Overview of the Patent Act	
(1) Purpose of the Patent Act .....	5
(2) Object of patent right.....	5
1) Definition of an invention.....	5
2) Categories of inventions .....	7
3) Conditions of patentability of inventions .....	8
i) Industrial applicability (main paragraph of Article 29 (1)) .....	8
ii) Novelty (Article 29 (1)(i) to (iii)).....	9
iii) Inventive step (Article 29 (2)).....	11
iv) Quasi-known (Article 29-2) .....	12
4) Reasons for unpatentability (Article 32) .....	12
(3) Subject of a patent right.....	13
1) Inventor.....	13
2) Right to obtain a patent.....	14
3) Infringement of the right to obtain a patent .....	15
4) Inventions by employees .....	16
5) Temporary exclusive license and temporary non-exclusive license .....	22
2. Acquisition of a Patent Right	
(1) Documents for patent application .....	23
1) Application.....	23
2) Description.....	23
3) Scope of claims.....	24
(2) Extraordinary patent applications.....	25
(3) Publication of application.....	25
(4) Right to claim compensation.....	25
(5) Examination procedure .....	26
1) Deferred examination system .....	26
2) Overview of examination procedure .....	27
(6) Registration of patent .....	28
3. Patent right	
(1) Effect of the patent right.....	30
(2) Restriction on effect of patent rights .....	35

1) Restriction on working of patented invention (use invention) .....	35
2) Statutory restrictions .....	36
i) Work for test/research .....	36
ii) International transportation merely passing through .....	36
iii) Other cases that patent right is not effective .....	36
3) Restriction by statutory non-exclusive license .....	37
4) Restriction by arbitrated license .....	37
5) Exhaustion of patent rights .....	37
i) Exhaustion in Japan .....	37
ii) Exhaustion in overseas .....	37
4. Licenses of Patent Rights (Exclusive License and Non-exclusive License)	
(1) General Overview .....	40
(2) Exclusive License .....	40
(3) Non-exclusive License .....	41
5. Infringement of Patent Rights	
(1) General Overview .....	44
(2) Direct Infringement of a Patent Right .....	44
1) Meaning of Direct Infringement .....	44
2) Literal Infringement of Patent Rights (Claim Interpretation) .....	44
3) Materials for Claim Interpretation .....	46
4) Patent Infringement by Equivalents (Doctrine of Equivalents) .....	48
5) Patent Infringements by Incomplete Working .....	50
(3) Indirect Infringement of a Patent Right .....	52
1) Meaning of Indirect Infringement .....	52
2) Indirect Infringement by Exclusive Products .....	53
3) Indirect Infringement by Non-Exclusive Products .....	55
(4) Civil Relief against Patent Infringements .....	57
1) Right to Seek Injunction .....	57
2) Claim for Damages .....	57
(5) Criminal Sanctions against Patent Infringement .....	58
6. Litigation Rescinding Trials and Appeals or Trial Decisions	
(1) Outline .....	59
(2) Appeal against Examiner's Decision of Refusal .....	60
1) The Purpose of the System .....	60
2) Reconsideration by Examiner Before Appeal .....	60
3) Proceedings and Trial Decisions .....	60
(3) Trial for Patent Invalidation .....	61
1) The Purpose of the System .....	61

2) Reasons for Invalidation.....	61
3) Request for Invalidation Trial.....	62
4) Request for Correction in Invalidation Trial.....	62
5) Effect of Proceedings and Trial Decisions .....	63
(4) Correction Trial .....	63
1) The Purpose of the System .....	63
2) Demandant of Correction Trial.....	64
3) Requirements for Correction Trial.....	64
(5) Opposition to a Granted Patent .....	65
1) The Purpose of the System .....	65
2) Reasons for Opposition to a Granted Patent.....	65
3) Procedures.....	65
(6) Litigation Rescinding the Trial Decision .....	66
1) Outline .....	66
2) Appropriate Party in the Case.....	66
3) The Time Limit for Institution of Action.....	67
4) Proceedings and the Scope of Proceedings .....	67
5) Ruling .....	68

## 1. Overview of the Patent Act

### (1) Purpose of the Patent Act

The Japanese Patent Act (hereinafter simply, “the Patent Act”) prescribes its purpose as follows: “The purpose of this Act is, through promoting the protection and the utilization of inventions, to encourage inventions, and thereby to contribute to the development of industry” (Article 1 of the Patent Act; hereinafter simply referred to as “Article 1” and so on by omitting “of the Patent Act”).

The Universal Declaration of Human Rights in 1948 sets forth in Article 27, paragraph 1, “Everyone has the right freely to participate in the cultural life of the community, to enjoy the arts and to share in scientific advancement and its benefits,” and in paragraph 2 of the said Article, “Everyone has the right to the protection of the moral and material interests resulting from any scientific, literary or artistic production of which he is the author.”

The Universal Declaration of Human Rights can be said to be explaining the reason for protection an invention with a patent right is because a patent right represents mental ownership. However, a more promising explanation than this is the industrial policy theory, which consists of the industrial encouragement theory, the laying open compensation theory, etc.

A judicial precedent states as follows: The patent system is intended to contribute to the development of industries by encouraging inventors by granting an exclusive right to use an invention for a certain period of time and, at the same time, by providing third parties with opportunities to use inventions laid open. (Supreme Court Decision of Apr. 16, 1999, Minshu Vol. 53 No. 4 p. 627 “Case of Therapeutic Agent for Pancreatic Disorders”).

### (2) Object of a patent right

#### 1) Definition of an invention

An object of a patent right is an invention. The Patent Act prescribes: “Invention” in this Act means the highly advanced creation of technical ideas utilizing the laws of nature (Article 2 (1)). This definition follows the theory of Dr. Kohler, a well-known German patent legal scholar.

An object of a patent right, or an invention under the Patent Act, must meet the following four requirements.

The first requirement is that an invention must utilize the laws of nature. Examples what cannot be said to be the laws of nature include the laws found through the purely intellectual and mental activities of human beings, such as the power of reasoning, artificial arrangements, economic laws and psychological laws. Examples of what cannot be said to be utilizing the laws of nature thus include the laws of nature themselves and methods of calculation, taxation, play and hypnosis. For example, a judicial precedent states that a calendar of great figures and the like, in which the illustrations, pictures, reading of names, maps showing the homeland of great figures, etc. are arranged, cannot be said to be utilizing the laws of nature (IP High Court Decision of March 6, 1993). On the other hand, there is a judicial precedent that found a dental therapy system utilizing computers and a network to be utilizing the laws of nature (IP High Court Decision of June 24, 2008 “Case of Dental Therapy System”).

No. 2 IP High Court Judgment Jun. 24, 2008 Hanji No. 2026 p. 123  
“Case of Bidirectional Dental Therapy System”

[Drawing] This is an outline block diagram showing the hue analysis system to capture images composed in accordance with one embodiment of the invention.

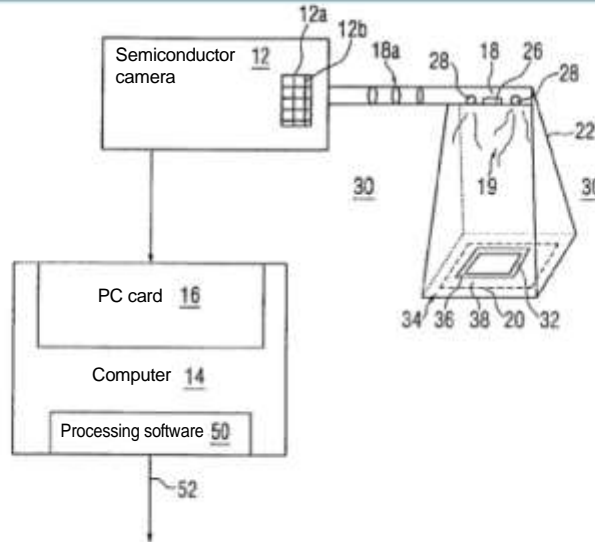

6

What does not utilize the laws of nature include those that contradict the laws of nature, such as a perpetual motion machine (Tokyo High Court Decision of March 27, 2002 Court Website “Perpetual Motion Machine of the First Kind”).

Perpetual Motion Machine in the Case of Perpetual Motion Machine of the First Kind

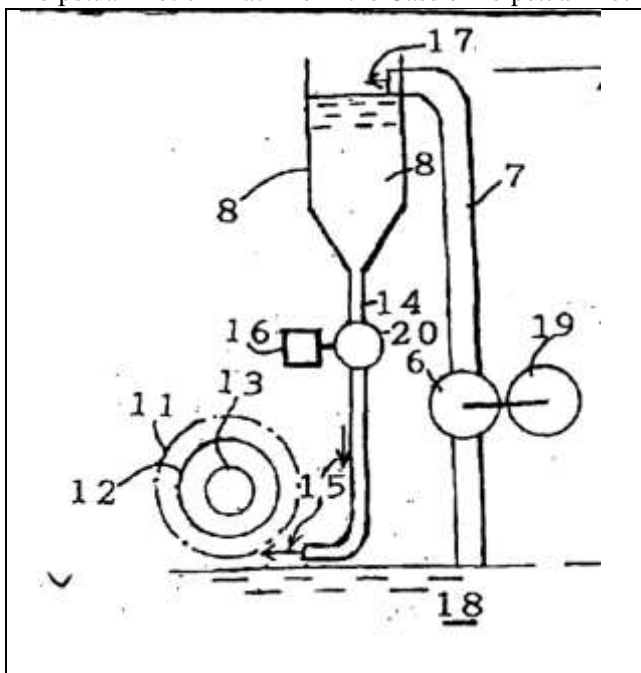

Inventions for which the utilization of the laws of nature becomes an issue include software-related inventions and business models, as well as artificial intelligence (AI), IoT and big data that are the central technologies of the fourth industrial revolution. However, these technologies are deemed to meet the requirement of the utilization of the laws of nature if they work in collaboration with hardware resources, i.e. computer systems.

The second requirement is that an invention must be a technical idea. An invention is required to address the three elements of technology, i.e. (a) problems, (b) means for solving the problems and (c) operation and effect, and to have replicability, enablement and objectivity. An invention for which problems and ideas are simply presented without showing concrete means for solving problems or an invention whose means of solving problems are not able to fulfil its objective are considered to be incomplete inventions and not granted protection (Supreme Court Decision of Jan. 28, 1969, Minshu Vol. 23 No. 1 p. 54 “Case of Nuclear Energy Generator”). An invention must have replicability but is not required to be highly replicable (Supreme Court Decision of Feb. 29, 2010, Minshu Vol. 54 No. 2 p. 709 “Case of Yellow Peach Breeding and Propagation Method”). An invention differs from a copyrighted work, in that the former is an idea in itself, but in the case of the latter, only the expression of thoughts, not thoughts themselves, is protected (refer to Article 2(1)(i) of the Copyright Act; hereinafter, when referring to the text of an Article, simply referred to as “Copyright Article 2 (1)(i)” and so on).

The third requirement is that an invention must be a creation. A creation refers to creating something through intellectual and mental activities. It differs from a discovery, which newly recognizes something that has already existed. The Patent Act clearly indicates that it does not protect a discovery. However, a so-called use invention can be granted patent protection in light of its usability although it is a discovery of a new use.

The fourth requirement is that an invention must be highly advanced. This requirement clearly indicates that inventions protectable under the Patent Act do not include those that are less advanced. This distinguishes a patent from a utility model, which protects a technical feature that is not highly advanced.

## 2) Categories of inventions

Inventions are grouped into two categories: inventions of a product and inventions of a process. Inventions of a product is further divided into two categories: inventions of a process of producing a product and other inventions of a process in a narrower sense (Article 2 (3) (i) to (iii)).

Since the effect of a patent right differs between an invention of a product and an invention of a process (Patent Article 68), it is a major practical issue in which category an inventor should state a completed invention in claims.

However, when judging patent applications to determine the identicalness between an invention of a prior application and an invention of a subsequent application, it is not precluded to find the two inventions to be identical if their technical ideas are identical to each other, even though the two inventions fall under different categories (invention of a product or a process) in terms of the statements in claims.

After an amendment of the Patent Act in 2002, a product as used in “invention of a product” may now be a “computer program, etc.” although it is an intangible. Also as a result of the amendment, the term “program, etc.” now includes “any other information that is to be processed by an electronic computer equivalent to a computer program” in addition to the previous definition “a set of instructions given to an electronic computer which are combined in order to produce a specific result.” In the case where a product relating to a patented invention is a computer program, etc., acts of working the invention now include “providing through an electronic telecommunication line.” This means that a patent right is effective against an act of transmitting a computer program over the Internet, leading to some overlap with a subdivided right of a copyright, i.e. the right of public transmission.

### 3) Conditions of patentability of inventions

#### i) Industrial applicability (main paragraph of Article 29 (1))

Industrial applicability means that (1) inventions that can be implemented theoretically and experimentally only, and (2) inventions in which whose the human body is a composing element, are excluded (Tokyo High Court Decision of Dec. 22, 1070, Han-ta No. 260 p. 334 “Case of Ion Toothbrush”).

Whether or not a method of operating, treating or diagnosing a human being, i.e. a method of medical treatment, satisfies the requirement of industrial applicability were discussed in many countries, including Japan. For example, the TRIPS Agreement in 1995 prescribes in Article 27, paragraph 3: Members may also exclude from patentability: (a) “diagnostic, therapeutic and surgical methods for the treatment of humans or animals.

A relevant judicial precedent held that a patent right cannot be granted to a method of medical treatment unless there is a provision in the Patent Act that prevents a patent right from being effective against the working of a patented invention by a physician, etc. In the decision, it was stated, with respect to whether or not a medical treatment is included in “industry” when considering its patentability, “Generally speaking, no inherent reason is found in the Patent Act for interpreting the meaning of “industry” more narrowly.” And then the following statement followed: “If a medical act is found to have patentability, physicians would have to address medical practice always worrying about being held liable for patent violation. The plaintiff’s argument that a medical act itself should be found patentable is worth listening as a legislative theory, but, as stated above, it cannot be adopted as an interpretation under the current Patent Act, which does not set out, as preconditions, necessary measures for recognizing patentability of medical acts (Tokyo High Court Decision of April 11, 1992, Haji No. 1828 p. 99 “Case of Surgical Operation Indication Method”). However, in the case of a patent right for a method of mixing two or more medicines, the patent right may possibly be interpreted as being not effective against the working of a patented invention by a physician, etc., based on the analogical application of the provision to the effect that such a patent right shall not be effective against the act of preparation of a medicine by a physician, etc. (Article 69 (3)).



Patent-applied Invention for surgical operation indication method in the Case of Surgical Operation Indication Method

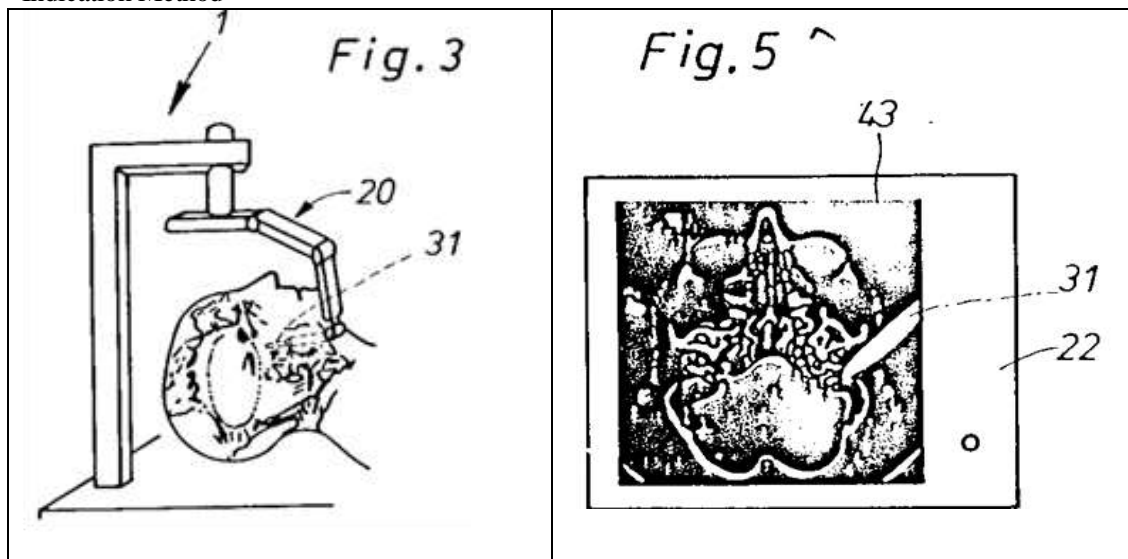

ii) Novelty (Article 29 (1)(i) to (iii))

Novelty means that an invention has not become a public property in society. The reason for not granting a patent right, which is an exclusive right, to an invention that has already been in the public domain is due to the purpose of the Patent Act; granting a patent to an invention already in the public domain does not encourage the development of technologies. If a patent right is allowed to become effective against technologies that are already publicly available, social order, in particular order in transactions, will be destroyed. Examples are (a) inventions known to the public, (b) inventions of public use and (c) inventions described in publications, etc.

① Inventions known to the public

This refers to inventions that were publicly known in Japan or a foreign country prior to the filing of the patent application (Article 29 (1)(i)).

“Prior to the filing of patent application” focuses on the time, rather than the date of patent application. These inventions include inventions publicly known not only in Japan but also in a foreign country (globalism).

“Publicly known” means becoming known to parties other than persons who are under the obligation of confidentiality. A judicial precedent states, “Even though the co-researchers and research assistants of an invention, persons who were involved in the examination to determine the effects of the completed invention, etc..... have the knowledge of the content of the invention, it does not mean that the invention is in principle publicly known or publicly worked” (Tokyo High Court Decision of Jun. 18, 1974, Mutaishu Vol. 6 No. 1 p. 170 “Case of Box-frame Type Building”). Another judicial precedent states, “If the content of an invention becomes known to parties who are in a relationship of confidentiality with the inventor, this does not constitute a “publicly known” situation as mentioned in Article 29 (1)(i) of the Patent Act. Such relationship of confidentiality with

the inventor arises by being imposed legal or contractual obligations of confidentiality .... and also arises in situations where these parties are implicitly required and expected to keep the invention in confidence under normal social conventions or in commercial customs, without being specifically directed or demanded (Tokyo High Court Decision of Dec. 25, 2010, Hanko [2nd phase] p. 531-50 “Case of 6-roll Calendar”).

② Inventions of public use

This refers to inventions that were publicly worked in Japan or a foreign country prior to the filing of the patent application (Article 29 (1)(ii)). The meanings of “prior to the filing of the patent application” and “in Japan or a foreign country” are the same as those in the sentence for inventions known to the public.

In order for an invention to be “worked publicly,” the invention must be being worked in such a way that can be known to anyone. Therefore, merely displaying a machine incorporating an invention inside does not mean that the invention is made publicly available.

③ Inventions described in publications, etc.

This refers to inventions that were described in a distributed publication or inventions that were made publicly available through an electric telecommunication line in Japan or a foreign country, prior to the filing of the patent application ((iii)).

A publication refers to a document, drawing or other information medium reproduced for the purpose of being publicized by distribution. A publication falls under the category of distributed publication when it is made available for inspection. A judicial precedent states, “A publication issued and distributed in a foreign country, once it has reached the Japanese Patent Office and accepted by its resource center, must be considered to be a ‘publication distributed in Japan’ as set out in Article 4(ii) of the former Patent Act (Supreme Court Decision of Jan. 29, 1963 Showa 6 (O) 1180 ”Case of Tetrapod”). Regarding an invention described in a publicized original, a judicial precedent states, “It can be a publication distributed in Japan as long as it is placed in a situation in which a copy thereof can be delivered without delay upon a request from an individual or entity. In that case, it is not necessary to make copies in advance, but rather, a copy may be made from the original and delivered only when a request is received (Supreme Court Decision of Jul. 4, 1980, Minshu Vol. 34 No. 4 p. 570 “Case of Single-lens Reflex Camera”). It should be noted, however, that there is a judicial precedent that states, “A publication cannot be said to be being distributed merely because it is copied and delivered each time a request is made” (Osaka High Court Decision of Oct. 4, 2012 Court HP “Case of Inner Mold’s Structure”).

Even in these situations constituting grounds for finding lack of novelty, where (a) lack of novelty is against the will of the person having the right to obtain a patent (Article 30 (1)), or (b) lack of novelty arises from an act of the person having the right to obtain a patent (Article 30 (2)), and if a patent application for the invention is filed within six months, the invention is deemed not to lack novelty in the course of judgment of novelty and inventive steps. This is the so-called grace period system.

A judicial precedent corresponding to (a) above is Tokyo High Court Decision of Apr. 26, 1972 Mutaishu Vol. 4 No. 1 p. 261 “Case of Towing Vehicle for Agricultural Use,” and a judicial precedent

corresponding to (b) above is Supreme Court Decision of Nov. 10, 1989, Minshu Vol. 43 No. 10 p. 1116 “Case of Cyclic Amin.” The precedent states, “When a person having the right to obtain a patent files a patent application and, as a result, the invention is printed in the laid-open disclosure public patent bulletin, it does not constitute an act of “making a presentation in a printed publication” as mentioned in Article 30 of the Patent Act.

The length of grace period was extended from six months to one year in the Act on the Amendment of Relevant Acts Due to the Conclusion of Trans-Pacific Partnership approved and passed on December 9, 2016.

Tetrapod of a patent-applied invention in the Case of Tetrapod

**Supreme Court Judgment Jan. 29, 1963 Showa 36 (O) 1180**  
**“Final Appellate Instance for the Case of Tetrapod”**

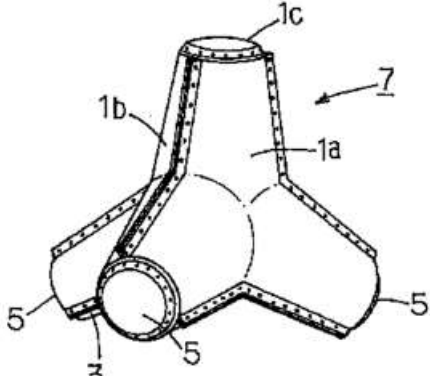

\* Tetrapod (registered trademark of Tetra Co., Ltd.)  
 [Name] Invention of Tetra Co., Ltd.'s patent application  
 “Tetrapod Dislocating Apparatus”  
 (Japanese Patent Laid Open 1996-74224)  
 From the laid-open disclosure public patent bulletin (Fig. 3)

47

iii) Inventive step (Article 29 (2))

An invention must involve an inventive step in order to be granted a patent right. Even when the invention is held to be novel, it cannot be granted a patent right if a person ordinarily skilled in the art of the invention (a person skilled in the art) would have been able to easily make the invention based on a non-novel invention (Article 29 (2)). The concept is called an inventive step. It can otherwise be referred to as difficulty in solving problems of an invention or accessibility to a constitution (features) differing from a prior art.

The reason why an inventive step is required is that granting an exclusive right to an art without an inventive step will impede free economic activities and the development of technologies.

Typical examples of inventions without an inventive step include those that represent (a) mere juxtaposition of publicly known art, (b) simple substitution of one known element for another and (c) simple diversion. As for inventions of business model, there exist many inventions that merely

implement conventional business models by use of the Internet. Against this background, the Patent Office issued in 2000, as the Patent Office Examination Guidelines, a negative list of inventions that are the results of merely adding minor enhancements or improving the efficiency of simple clerical work.

However, “Mapion Patent,” which provides map information, and “Kanban System,” which improves efficiency in the production of automobiles, were recognized to involve an inventive step.

Involvement of an inventive step is judged by comparing a patent-applied invention and a publicly known invention (cited invention) as a prior art, identifying the common points and differences between the two inventions, and then determining whether or not the patent-applied invention was able to be reached easily because a part of the constitution of the cited invention provides motivation to the inventor to decide on the constitution of the patent-applied invention. A judicial precedent states that a judgment of involvement of an inventive step must be made by first identifying the features of the invention (problems to be solved by the invention), and then identifying the existence of suggestions, etc. that must have been made by the prior art to allow the patent-applied invention to reach its features (IP High Court Decision of Jan. 28, 2009 Hanji No. 2043 p. 117 “Case of Connecting Member for Circuits”). Another judicial precedent states that a judgment must be made to determine whether or not the problems to be solved were able to be set easily, and a logical explanation supported by evidence is of critical importance in making such a judgment (IP High Court Decision of Jan. 31, 2011 Hanji No. 2107 p. 131 “Case of Filter for Ventilating Fan”).

#### iv) Quasi-known (Article 29-2)

Where an invention claimed in a patent application is identical with an invention disclosed in the description, scope of claims or drawings (in the case of the foreign language written application under Article 36-2(2), foreign language documents as provided in Article 36-2(1)) originally attached to the application of the written application of another application for a patent which has been filed prior to the date of filing of the said patent application, the invention cannot be granted a patent except where the inventor or applicant is the same person. The concept is called “quasi-known” or “expansion of the scope of a prior application.”

In accordance with this concept, prior art effect is provided to a prior invention to the maximum extent possible in which a patent right can be acquired through the documentation of the prior art.

It should be noted that in the case where a prior application for registration of a utility model exists before the filing of a patent application, subsequent patent applications are excluded in a similar manner when a bulletin containing the utility model is issued.

#### 4) Reasons for unpatentability (Article 32)

The Patent Act does not allow an invention, even if it satisfies the aforementioned requirements for patentability, to be patented from the viewpoint of protecting public interests. The concept is called reasons for unpatentability.

Inventions constituting a reason for unpatentability include an invention that is liable to injure public order, morality or public health. An invention that is liable to injure public order and morality means that the working of an invention to accomplish its intended purpose may injure public order and morality (Tokyo High Court Decision of Dec. 25, 1986, Mutaishu Vol. 18 No. 3 p. 579 “Case of Bank

Note”). One example of such invention is a bank note forging machine. A mere possibility to be made available for use for fraudulent activities does not make an invention liable to injure public order and morality (Tokyo High Court Decision of Dec. 15, 1956, Gyosaireishu Vol. 7 No. 12 p. 3133 “Case of Bingo Game”).

10,000 yen note for which a patent application was filed in the Case of Bank Note

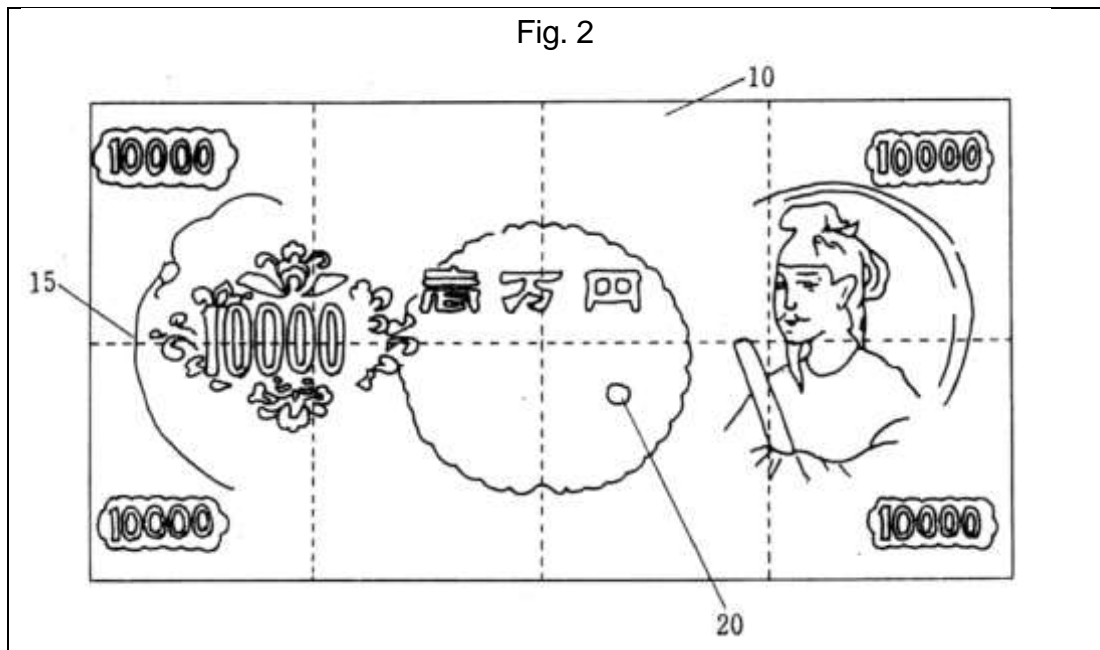

### (3) Subject of a patent right

#### 1) Inventor

A person who is inherently entitled to obtain a patent right is the inventor of an invention. An inventor is limited to a natural person, and no judicial person can be an inventor (see Patent Article 35). An inventor is granted, as a moral right, the right to have his/her name stated as an inventor (Article 36 (1)(ii), Article 66 (3)(iii), Patent Enforcement Article 66(iii) and Paris Convention Article 4-3) and, as a property right, the right to obtain a patent (Article 29 (1), Patent Article 33 (1)).

An inventor refers to a person who actually created a technical idea. A judicial precedent states, “An inventor is a person who was involved in the creation of an advanced technical idea utilizing the laws of nature, or a person who was involved in the creative activity to constitute the technical idea into a concrete and objective thing to the extent that a person skilled in the art can work (IP High Court Decision of May 29, 2008, Hanji No. 2018 p. 146 “Case of Glass Madreporite”). Another judicial precedent further states, “In order for a person to be a real inventor (co-inventor), the person needs to have actually taken part in the act of creation pertaining to the technical idea” (Tokyo District Court Decision of Sep. 13, 2005, Hanji No. 1916 p. 133 “Case of Pfizer”).

Therefore, those who cannot be said to be an inventor include “--- a person who, as a manager, conducted general management for the researcher who is his/her subordinate, a person who gave

general advice and guidance, a person who, as an assistant, simply compiled data or conducted experiments in accordance with the instructions given by the researcher, a person who provided a fund to the researcher, a person who assisted the researcher in completing the invention by allowing the researcher to use facilities, a person who entrusted the researcher with the completion of the invention, and the like” (IP High Court Decision of May 29, 2008, Hanji No. 2018 p. 146 “Case of Glass Madreporite”).

## 2) Right to obtain a patent

The right of an inventor to obtain a patent as a property right is a right to use, acquire income from and dispose of an inventory, and can be said to be a right to an invention that satisfies the requirements for patentability, which lasts until a patent right is registered.

The right to obtain a patent, being a property right, may be transferred (Article 33 (1)), in which case the successor to whom the patent was transferred obtains the patent right. The successor of the right to obtain a patent cannot be perfected against a third party unless he/she files a patent application (Article 34 (1)); provided, however, that in the case of a double assignment of the right to obtain a patent, the person who filed a patent application cannot be perfected against the assignor’s ex-employer, etc. if that act constitutes an act in breach of trust, examples of such situation including where the assignee is aware of the fact that the assignor’s ex-employer, etc. succeeded to the right to obtain a patent or that the invention was held by an ex-employer, etc. under confidential control (IP High Court Decision of Feb. 24, 2010, Hanji No. 2102 p. 98 “Case of Employee Invention of Working Tool”).

Any succession to the right to obtain a patent after the filing of the patent application shall have no effect, except in the case of general successions including inheritance, without notification to the Commissioner of the Patent Office (Article 34 (4)). Where a general succession to the right to obtain a patent including inheritance thereof occurs, the successor in title shall notify the Commissioner of the Patent Office thereof without delay (Article 34 (5)).

In the case of a joint invention, for which the right to obtain a patent is jointly owned, no joint owner may assign his respective share without the consent of all the other joint owners (Article 33 (3)). Furthermore, no joint owner may establish a temporary exclusive license or grant a temporary non-exclusive license to any third party (Article 33 (4)). Where the right to obtain a patent is jointly owned, a patent application may only be filed by all the joint owners (Article 38). Where the patent application is not filed jointly, the application will be refused (Article 49) and be invalidated (Article 123 (1)(ii)). The jointly-owned right to obtain a patent becomes a jointly-owned patent right by the registration of establishment (Article 73).

While the right to obtain a patent is a property right, it may not be the subject of a pledge for reasons of lack of means of public disclosure, etc. (Article 33 (2)), but may be subject to a security by way of assignment or other security.

The right to obtain a patent will lapse in cases where a patent right is registered, a decision of refusal becomes final, no heir exists, the judicial person dissolves itself or the right is waived.

3) Infringement of the right to obtain a patent (unauthorized use, misappropriated application and the right to request transfer of patent right)

Examples of infringement of the right to obtain a patent include unauthorized working and unauthorized patent application by a person who does not have such right. Infringement of the right to obtain a patent by unauthorized working is called unauthorized use. Against this type of infringement, injunction will not be granted because it is not yet a patent right, which is an exclusive right, but the right to claim for damage will be granted.

Infringement of the right to obtain a patent by an unauthorized patent application is called a misappropriated application, which will constitute a reason for refusal (Article 49 (vii)) and a reason for invalidation (Article 123 (1)(vi)).

In the event of a misappropriated application and if it occurs before a patent right is established, the true right holder can acquire a patent right by obtaining a declaratory judgment pertaining to the right to obtain a patent against the person who filed a misappropriated application and by filing an application for change of the name of the applicant.

In the event of a misappropriated application and if the applicant of such application has acquired a patent right, the right to request for registration of the transfer of a patent right has been granted to the true right holder, based on a judicial precedent (Supreme Court Decision of Jun. 12, 2001, Hanji No. 1753 p. 119 “Case of Garbage Disposer”). This right was clearly stated in the law by an amendment in 2011 (Article 74 (1)).

When registration of transfer is approved, based on the right to request for registration of the transfer of a patent right, a person who was originally the true holder of the right to obtain a patent is now deemed to have not only a patent right, but also the right to claim compensation based on the laying open of the application (Article 74 (2)). The holder of a patent right who made a misappropriated application in good faith and the licensee of such patent right are now granted a statutory non-exclusive license, so as to allow them to continue, under certain conditions, the business based on the working of the patented invention, subject to the payment of a reasonable value (Article 79 -2).

## Garbage disposer in the Case of Garbage Disposer

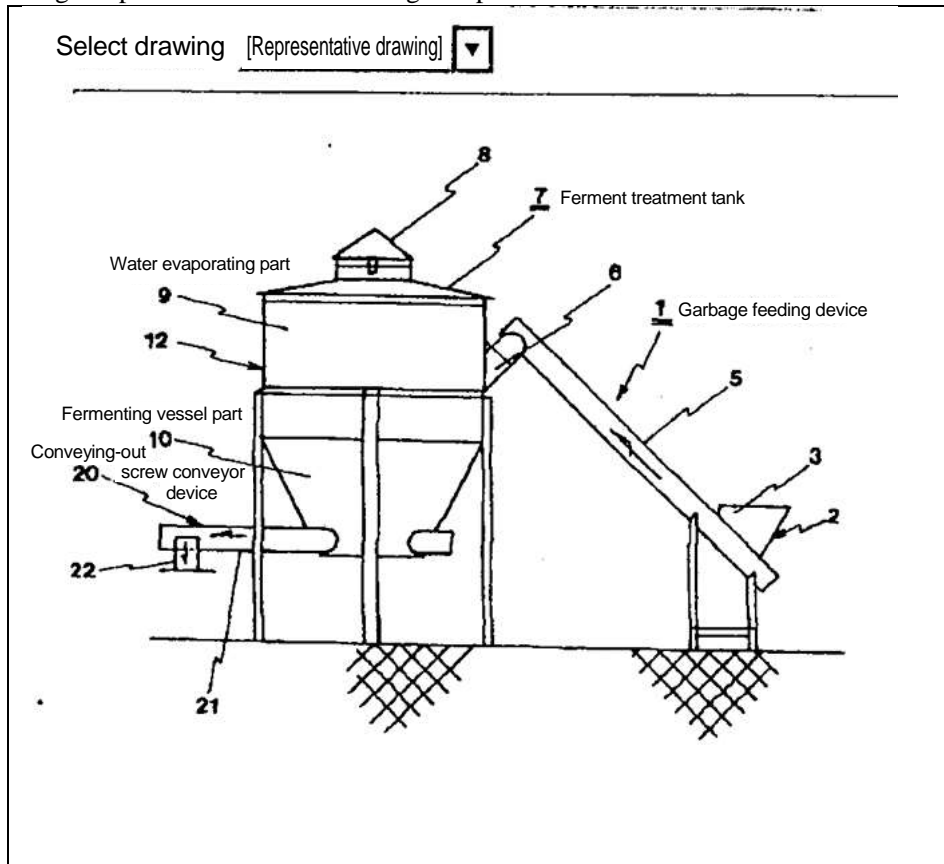

### 4) Inventions by employees

#### i) Purpose of the employee invention system

Similarly to general inventors, a researcher or engineer who belongs to a company, university or other organization is granted, as a moral right, the right to have his/her name stated as an inventor and, as a property right, the right to obtain a patent.

The right to obtain a patent of an inventor at a company, etc. may also be transferred (Article 33 (1)). Therefore, the current Patent Act of 1960 introduced an employee invention system modeled after the German Employees' Invention Law of 1957. This system recognizes the possibility for a company, etc. to obtain a patent right and requires the company, etc. to return a certain amount of profit to its employee who is an inventor. At first, the employee invention system was understood to be a system aiming at protecting workers at companies, etc. In recent years, it has become regarded as a system to align between the interest of a company, etc. and that of an employee inventor.

A judicial precedent states, "Article 35 of the Patent Act (which relates to inventions by employees) aims at --- protecting the interest of an employer, etc. and that of an employee, etc. and aligning between the interests of the two parties" (Supreme Court Decision of Apr. 22, 2003 Minshu Vol. 57 No. 4 p. 477 "Appeal Trial of the Case of Olympus Optics"). However, another judicial precedent states, "The purpose of Article 35 is to protect inventor employees and thereby to realize the purpose of the Patent Act to encourage inventions and thereby to contribute to the development of



industry (Supreme Court Decision of Oct. 17, 2006 Minshu Vol. 60 No. 8 p. 2853 “Case of Employee Invention of Hitachi”).

The employee invention system was amended in 2015 to allow an employer, etc. to become the original acquirer of the right to obtain a patent through a contractual arrangement, etc., and to modify the right of an employee, etc. to receive a “reasonable profit,” rather than a “reasonable value.”

## Overview of the Employee Invention System

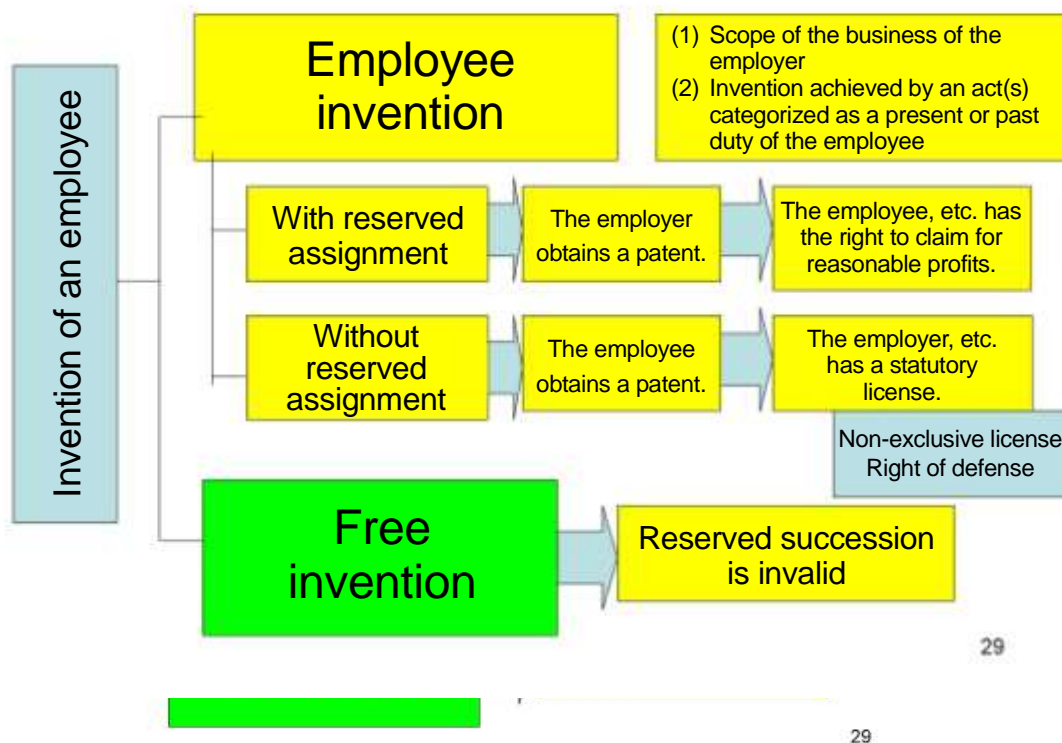

### ii) Meaning of and requirements for employee invention

An employee invention means an invention which is made by an employee, an officer of the juridical person, or a national or local government employee (hereinafter, "employee, etc."), which, by the nature of the said invention, falls within the scope of the business of the employer, the juridical person or the national or local government (hereinafter, "employer, etc.") by which the employee is employed, and which was achieved by an act(s) categorized as a present or past duty of the said employee, etc. (Article 35 (1)).

The “scope of the business” of an employer, etc. means the business being currently conducted and concretely planned for the future by the employer, etc., and should not be judged by adhering to the descriptions in the articles of incorporation, etc. of a company. Where an inventor is a national or local government employee, it means the scope of the business under the responsibility of the body to which the employee belongs.

It should be noted that “an act(s)” as used in the passage “(an invention which was achieved by) an

act(s) categorized as a present or past duty of the said employee, etc. performed for the employer, etc. falls within the scope of the business of the said employer, etc.” means an act of research and development and not an act of invention itself. “Employee, etc.” includes not only those who are employed by the employer, etc. but also those who are under the control and supervision of the employer, etc. (Osaka District Court Decision of May 23, 2002 Court HP, “Case of Inventor’s Good Name Right”). Therefore, persons who are part-time or temporary employees are also “employees, etc.” for the purpose of employee invention. A “past duty” means a previous duty for the same employer, etc., not after retirement, wherein in the course of such duty, an act of research and development is planned and expected. Any invention that falls within this category of duty is deemed to be an employee invention, including those achieved by the employee, etc. through research and development based on the employee’s free conception.

A judicial precedent states, “(An employee invention) is taken to include an invention completed under a situation in which making such invention was not clearly stated as part of the primary duty of the employee but the employee him/herself found the theme of research voluntarily and completed the invention, if from an objective point of view and based on the nature of the primary duty of the employee, it is deemed that the employee’s attempting to make such an invention and endeavoring to complete the invention is generally planned and expected, and if the employer contributed to the completion of the invention through such acts as assisting the research and development by offering facilities to the employee to facilitate the completion of the invention” (Osaka High Court Decision of Apr. 28, 1994, Hanji No. 1542 p. 115 “Case of Thermos Bottle”). On the other hand, the invention of blue light emitting diode, which was awarded a Nobel Prize in 2014, was found to be an employee invention because “the inventor made the invention during the working hours, within the facility of the defendant company, using the equipment of the defendant company and also using the labor, etc. of the assistants who were the employees of the defendant company (Tokyo District Court Decision of Sep. 19, 2002, Hanji No. 1802 p. 30 “Interlocutory Decision for the Case of Blue Light Emitting Diode”). The interpretation of employee invention in this decision impresses many as being too narrow.

Invention of blue light emitting diode by Mr. Shuji Nakamura, the plaintiff, in the Case of Blue Light Emitting Diode

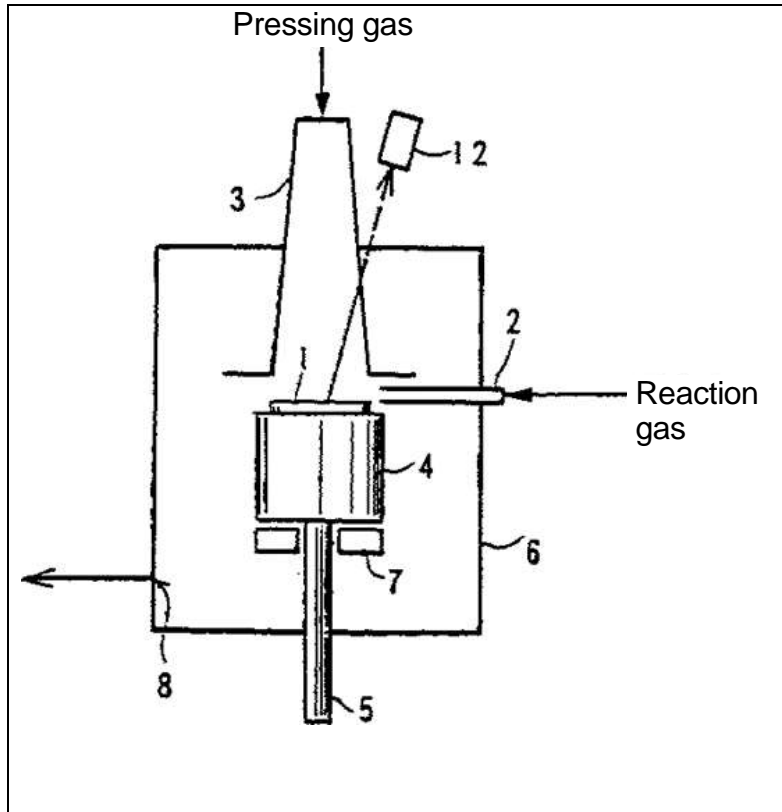

iii) Statutory license of an employer, etc. for an employee invention

An employer, etc., where its employee, etc. has obtained a patent for an invention or where the successor to the right to obtain a patent for the employee invention has obtained a patent, shall have a non-exclusive license on the said patent right (Article 35 (1)).

The non-exclusive license of the employer, etc. is the so-called right of defense. It is a statutory non-exclusive license introduced to align between the interests of the parties concerned in the case where an employee, etc., or the successor to the right of the employee, etc. to obtain a patent, obtained a patent for an employee invention for which the employer, etc. spent a capital.

iv) Reserved assignment of the right to obtain a patent, etc.

The Patent Act sets forth that any provision in any agreement, employment regulation or any other stipulation providing in advance that the right to obtain a patent shall vest in the employer, etc. shall be null and void unless the said invention is an employee invention (Article 35 (2)).

Based on an opposite interpretation thereof, such provision is taken to be valid in the case of an employee invention. In addition, in accordance with the amended Act of 2015, the right to obtain a patent is deemed to be held by the employer, etc. (Article 35 (4)).

It has been said that there are three theories expressing the legal nature of reserved assignment, which is permitted with respect to an employee invention. They are (a) transfer of right subject to a

condition precedent, (b) unilateral reservation and (c) unilateral agreement. A judicial precedent adopted the theory of transfer of right subject to a condition precedent and stated, “A transfer of the right to obtain a patent in this case does not specifically require the inventor to take any action for the transfer, but the right is transferred automatically and ideologically in accordance with the provisions of the said rules (Osaka District Court Decision of May 18, 1979, Torikeshishu 1979 p. 139 [Case of Continuous Kneading Machine]. IP High Court Decision of Feb. 24, 2010, Hanji No. 2102 p. 98 “Case of Employee Invention of Working Tool” states to the same effect). In practice, however, most cases have been addressed based on the theory of unilateral reservation. Since the enforcement of the amended Act of 2015, this basis theory has undergone changes into that of contractual arrangement, etc. for original acquisition.

v) Right to receive reasonable profits

In the case of an employee invention, an employee, etc. who invented such invention has the right to receive “reasonable monetary or other economic profits” when his/her right to obtain a patent has been succeeded to and owned by the employer, etc. (Article 35 (4)).

The amount of a “reasonable profit” to be paid with respect to an employee invention may be determined in advance in accordance with the provisions of an agreement, employment regulation and other stipulation . However, the Patent Act prescribes that such amount “shall not be considered unreasonable in light of circumstances where a negotiation between the employer, etc. and the employee, etc. had taken place in order to set standards for the determination of the said value, the set standards had been disclosed, the opinions of the employee, etc. on the calculation of the amount of the value had been received and any other relevant circumstances.” (Article 35 (5)). In judging the reasonableness of the amount of a “reasonable profit” to be paid to the employee, etc., much importance is placed on the reasonableness of the procedure taken between the employer, etc. and the employee, etc. in the course of setting standards and determining the details of individual profits.

As for the reasonableness of payment of a reasonable profit for an employee invention, a case related to a “reasonable value” that took place prior to the enforcement of the amended Act of 2015 held that whether or not the value is unreasonable should be judged by taking into consideration (a) circumstances where a negotiation between the employer, etc. and the employee, etc. had taken place in order to set standards for the determination of the said value, (b) whether or not the set standards had been disclosed, (c) the opinions of the employee, etc. on the calculation of the amount of the value and (d) any other relevant circumstances. Based on this provision, a case stated that if any of the procedures (a) to (c), which are shown as examples of factors to be considered, has not been taken, payment of the value in accordance with the provisions of the work regulation, etc. must be judged to be unreasonable unless there are special circumstance in which, for example, a measure to protect the interest of the employee, etc. that can be a satisfactory alternative to the lacking procedure has been secured or the amount of the value calculated in accordance with the provisions more than makes up for the procedural deficiency (Tokyo District Court Decision of October 30, 2014, Court HP “Case of Nomura Securities’ Employee Invention”).

As a result of this decision, any value, if judged not to be unreasonable, would be treated as the amount of a reasonable profit. In order to secure the procedural reasonableness of this treatment, a

guideline has been issued by the Minister of Economy, Trade and Industry to the effect (Article 35 (6)).

vi) Amount of reasonable profit

Where any provision related to a reasonable profit does not exist in any agreement or work regulation, or where it is found to be unreasonable for an employee, etc. to be given a profit that is deemed to be reasonable under such provisions, a reasonable profit would be determined by a court. In doing so, the court must determine the amount by taking into account the amount of a profit to be received by the employee, etc. based on the invention, the amount borne and contribution made by the employer, etc. in relation to the invention, the treatment of the employee, etc. and any other relevant circumstances (Article 35 (7)). As the reasonable profit mentioned in this provision, a judicial precedent identified an amount of 60.4 billion yen, based on the interpretation that the aforementioned “profit to be received by the employee” is the “profit by exclusive monopoly,” and determined the “amount of the value to be received by the employee, etc.” to be 20 billion (Tokyo District Court Decision of Jan. 30, 2004, Hanji No. 1852 p. 36 “Case of Blue Light Emitting Diode”). The right to claim a profit based on the reserved succession of the right to obtain a patent in a foreign country is also subject to the analogical application of Article 35 of the Japanese Patent Act as with the case of the judicial precedent (Supreme Court Decision of Oct. 7, 2006 Minshu Vol. 60 No. 8 p. 2853 “Case of Hitach’s Employee Invention”).

The extinctive prescription of the right of an employee, etc. to claim a reasonable profit is subject to the application of the Civil Code, which amendment was promulgated in 2017. Before the amendment of the Civil Code, there had been a theory that the extinctive prescription of the right to claim a reasonable profit should be five years, as with the case of claims under the Commercial Code. However, in a commonly accepted theory and judicial precedents, the extinctive prescription of the same right was ten year from the time when the right becomes enforceable (Article 167 of the Civil Code before amendment). In addition, where the time of payment was prescribed in an agreement, etc., the extinctive prescription of the same right was ten years from such time (Tokyo District Court Decision of Feb. 24, 2004, Hanji No. 1853 p. 38 “Case of Ajinomoto’s Aspartame” and others), and ten years from the time of succession where the time of payment was not prescribed (Supreme Court Decision of Apr. 22, 2003 Minshu Vol. 57 No. 4 p. 477 “Olympus Optics’ Employee Invention”). In the amendment of the Civil Code in 2017, the extinctive prescription of claims was changed to either five years from the time when the creditor becomes aware that he/she can exercise his/her right (subjective starting point of reckoning) or ten years from the time when the creditor can exercise his/her right (objective starting point of reckoning), whichever is earlier (Article 166 (1)(i) and (ii) of the Civil Code after amendment). The extinctive prescription of the right of the employee investor to claim a profit must be interpreted under this provision.

#### 5) Temporary exclusive license and temporary non-exclusive license

For licenses before a patent right is established, the system to register a temporary exclusive license or a temporary non-exclusive license was introduced by the amendment in 2008.

A temporary exclusive license may be set for a patent right to be vested based on the right to obtain a patent, within the scope written in the initial document attached to the patent application form (Article 34-2 (1)). A temporary exclusive license becomes effective upon the registration of a patent (Article 34-4). After the establishment of the patent right is registered, an exclusive license is deemed to have been established (Article 34-2 (2)).

A temporary non-exclusive license is granted for a patent right to be vested based on the right to obtain a patent, within the scope set forth in the initial document attached to the patent application form (Article 34-3 (1)). As for a temporary non-exclusive license, its registration was a requirement for perfection against a third party. After the amendment in 2011, a temporary non-exclusive license may now be perfected against a third party without being registered (Article 34-5). A temporary non-exclusive license is deemed to have been granted after the establishment of the patent right is registered (Article 34-3 (2)).

## 2. Acquisition of a Patent Right

### (1) Documents for patent application

#### 1) Application

An application is a written application for granting a patent right. An application must state (a) the name and domicile or residence of the applicant and (b) the name and domicile or residence of the inventor(s) (Article 36 (1)). The inventor(s) stated in the application must be a natural person(s); no judicial person may be an inventor.

The description, scope of claims, drawings (where required), and abstract must be attached to the application.

#### 2) Description

The description must state (a) the title of the invention, (b) a brief explanation of the drawing(s) and (c) a detailed explanation of the invention (Article 36 (3)).

A detailed explanation of the invention, among the matters to be stated in the description, is as important as the scope of claims that is described in the following section. A detailed explanation of the invention is a document to disclose the invention for which a patent application was filed. This document, in addition to having the function as a prior art document, is used as a material when the technical scope of a patented invention is determined. The meaning of each term used in the scope of claims is interpreted in consideration of the statements in this part of the description and the drawings (Article 70 (2)).

The statement of the detailed explanation of the invention must comply with each of the following items:

- ① in accordance with Ordinance of the Ministry of Economy, Trade and Industry, the statement must be clear and sufficient as to enable any person ordinarily skilled in the art to which the invention pertains to work the invention;
- ② where the person requesting the grant of a patent has knowledge of any inventions (inventions as provided in Article 29(1)(iii), hereinafter the same shall apply in this item) related to the said invention, that has been known to the public through publication at the time of filing of the patent application, the statement shall provide the source of the information concerning the invention(s) known to the public through publication such as the name of the publication and others.
- ① is the so-called “enabling requirement.” Any violation of this requirement is regarded as being deficient in disclosure and constitutes a reason for refusal and a reason for invalidation (Article 49 (iv), Article 123 (1)(iv)). Many judicial precedents explain this requirement as a ground for granting a patent right, from a viewpoint of the laying open compensation theory.
- ② is the so-called “requirement for disclosure of information on prior art document.” Any violation of this requirement constitutes a reason for refusal (Article 49 (v)) but not a reason for invalidation.

### 3) Scope of claims

The scope of claims is in practice called “claims.” This is a document that states the scope within which a patent right is sought with respect to the invention for which a patent application was filed. Examination of requirements for patentability is conducted with respect to the creation of a technical idea to be made based on the statements in the claims, or the “subject-matter of the invention.” Once a patent right is granted, the technical scope of the patented invention in relation to the patent right must be determined (Article 70 (1)).

The statement of the claims must comply with each of the following items (Article 36 (6)).

- ① The invention for which a patent is sought is stated in the detailed explanation of the invention;
- ② The invention for which a patent is sought is clear.
- ③ the statement for each claim is concise; and
- ④ the statement is composed in accordance with Ordinance of the Ministry of Economy, Trade and Industry.

An application in violation of this requirement is regarded to constitute a reason for refusal (Article 49) and a reason for invalidation (Article 123 (1)(iv)).

- ① is the so-called “support requirement,” which prohibits the scope as stated in the claims within which a patent is sought from exceeding the invention stated in the detailed description of the invention (IP High Court Decision of Jan. 28, 2010, Hanji No. 2073 p. 105 “Case of Flibanserin”).
- ② is called the “clarity requirement.” A typical example in which the clarity requirement becomes an issue is a case of the so-called “product-by-process claims” (hereinafter, “PBP”) in which the claims of an invention of a product state the process to manufacture the product for the purpose of identifying the product. In such a case, the problems of the identification of a gist and the identification of the technical scope of the patented invention arise.

Opinions on this matter were divided between the Intellectual Property High Court and those of the Supreme Court.

The Intellectual Property High Court distinguished between “true PBP” and “pseudo PBP,” and held that in the case of true PBP, the technical scope is effective against an art worked by a third party using a different process, while in the case of pseudo PBP, the technical scope is not effective against such an art (IP High Court Decision of Jan. 27, 2012 Minshu Vol. 69 No. 4 p. 822 “appellate instance of the Case of Pravastatin”). This is based on the so-called “manufacturing-process limitation theory.”

On the other hand, the Supreme Court adopts the so-called “product identity theory.” It stated that the technical scope is effective against another product in the case where such product is identical with the product of the patented invention, even if its manufacturing process is different (Supreme Court Decision of Jun. 5, 2015 Minshu Vol. 69 No. 4 p. 700 “Final Appellate Instance of the Case of Pravastatin”).



## (2) Extraordinary patent applications

The patent applications in the foregoing are ordinary ones. Extraordinary patent applications include the following:

- i) Priority claim under the Paris Convention (Paris Convention Article 4, Patent Article 43);
- ii) Priority claims recognized under the Paris Convention (Patent Article 43-2);
- iii) International application under the PCT (PCT Article 11 (3), International Application Act);
- iv) National priority claim application (Article 41)
- v) Division of patent applications (Article 44)
- vi) Conversion of application (Article 46)
- vii) Foreign language application (Article 36-2)
- viii) Patent applications based on utility model registration (Article 46 -2); and
- ix) Application for extension of duration (Article 67 (2))

## (3) Publication of application

After a lapse of one year and six months from the date of the filing of a patent application, the Commissioner of the Patent Office must lay open the patent application, except in the case where gazette containing the patent has already been published (Article 64 (1)). Even before a lapse of one year and six months from the date of the filing of a patent application, the applicant may file a request for the laying open of the patent application (Article 64-2), in which case the provision of Article 64 (1) similarly applies.

The laying open of a patent application is effected by stating the following matters in the patent gazette; provided, however, that this does not apply to the matters prescribed in items (iv) to (vi) where the Commissioner of the Patent Office recognizes that public order or morality is liable to be injured by stating such matters in the patent gazette (Article 64 (2)):

- ① the name, and the domicile or residence of the applicant(s) for the patent;
- ② the number and the filing date of the patent application;
- ③ the name, and the domicile or residence of the inventor(s);
- ④ the matters stated in the description, scope of claims attached to the application and the contents of the drawings attached to the said application;
- ⑤ the matters stated in the abstract attached to the application;
- ⑥ in the case of a foreign language written application, the matters stated in documents in foreign language and the abstract in foreign language;
- ⑦ the number and the date of laying open of the patent application; and
- ⑧ other necessary matters.

## (4) Right to claim compensation

By laying open a patent application, there arises the possibility that the invention may be worked by a third party. Assuming the possibility, the Patent Act allows an applicant to claim compensation against such third party after the laying open of the patent application (Article 65 (1)).

The right to claim compensation is a right by which, after the laying open of a patent application and where the applicant for the patent has given warning with documents stating the contents of the

invention claimed in the patent application, the applicant can claim compensation against a person who has worked the invention as a business after the warning and prior to the registration establishing a patent right. The amount of compensation is to be equivalent to the amount the applicant would be entitled to receive for the working of the invention if the invention were patented. Even where the said warning has not been given, the same will apply to a person who knowingly commercially worked an invention claimed in a laid open patent application, prior to the registration establishing a patent right;

provided, however, that, in order to prevent the abuse of the right to claim compensation under the preceding paragraph, it may not be exercised until the registration establishing a patent right has been effected, because the right to claim compensation is granted upon the laying open of a patent application regardless of whether the request for examination thereof has been made (Article 65 (2)). The exercise of the right to claim compensation does not preclude the exercise of the patent right. This means that a patent application is entitled to a relief continuously, in the form of the right to claim compensation in an amount of a reasonable license fee before the establishment of the patent right and in the form of the right to seek injunction and the right to claim damage after the establishment of the patent right.

If an exclusive licensee or non-exclusive licensee has worked the invention claimed in the patent application to the extent permitted by the contract granting the license, the patent applicant may not claim payment of compensation (Article 65 (3)), while a third party may make a defense to the effect that he/she has the status of the future holder of prior use and is expressly permitted to make an invalidity defense.(Article 65 (6), Article 104-3).

## (5) Examination procedure

### 1) Deferred examination system

Not all the patent applications filed are subject to examination to determine whether or not to grant a patent right. Examination of requirements for patentability is conducted on an application only if a request for examination has been filed by its applicant. This is called the deferred examination system. The system provides applicants with an opportunity to re-evaluate the invention for which a patent application has been filed to determine whether or not to seek a patent of the invention, and allows the Patent Office to reduce the negative effects of delay in examination to some extent by avoiding unnecessary examination.

A request for examination under this system may be filed by a third party (Article 48-3 (1)). This is because there are cases where a third party may have a stake in whether or not the patent application is granted a patent.

## 2) Overview of examination procedure

### i) Substantive examination

Examination of patent applications is conducted by an examiner on behalf of an independent administrative body to determine whether or not any of the following reasons for refusal (Article 49 (i) to (vii)) exists:

- ① an amendment made to the description, scope of claims or drawings attached to the application of a patent application does not comply with the requirements as provided in Article 17-2 (3) or (4);
- ② the invention claimed in the patent application is not patentable under Article 25, 29, 29-2, 32, 38 or 39 (1) to 39 (4);
- ③ the invention claimed in the patent application is not patentable under the provisions of any relevant treaty;
- ④ the patent application does not comply with the requirements under Article 36 (4) (i), 36 (6), or 37;
- ⑤ where notice under the preceding Article has been given, following the amendment of the description or submission of the written opinion, the patent application does not comply with the requirements under Article 36 (4) (ii);
- ⑥ where the patent application is a foreign language written application, matters stated in the description, scope of claims or drawings attached to the application of the said patent application do not remain within the scope of matters stated in foreign language documents; and
- ⑦ where the applicant for the patent does not have the right to obtain a patent for the said invention (misappropriated application).

### ii) Amendment

Amendment is a system to provide applicants with opportunities to supplement and correct proceedings within the extent not prejudicial to the interests of third parties. This system is provided because, under the first-to-file principle, applicants tend to rush the filing of applications, often leading to defects in proceedings and inadequacies in their applications, descriptions, scopes of claims, drawings, etc.

Amendments are divided into three categories: (a) procedural amendment to correct forms (text body of Article 17 (1)), (b) substantive amendment to correct the substance of the patent application documents (Article 17 (3)) and (c) voluntary amendment, which is made by applicants voluntarily (Article 17 (1)).

The most significant effect of amendment is the ability to go back to the date of application.

If extensive amendment is permitted, the interests of third parties may be prejudiced. In order to prevent this, the policy of restricting amendments has been adopted.

Restrictions on amendment are divided into two categories: time-wise restriction and content-wise restriction.

Time-wise restriction on amendments is relatively modest before the service of the certified

copy of the examiner's decision. An applicant for a patent is allowed to amend at any time the description, scope of claims, or drawings attached to the application; provided, however, that, except in the case where the said amendment is made through the submission of a statement of correction of an incorrect translation, any amendment of the description, scope of claims or drawings (in the case of a foreign language written application, the translation of the foreign language documents submitted as provided in Article 36-2 (2)) must be made within the scope of the matters described in the description, scope of claims or drawings originally attached to the application (Article 17-2 (3)). In other words, the so-called new matter may not be introduced. This is called in practice the "prohibition of new matter."

Time-wise restriction on amendments becomes more stringent after the initial service of the reason for refusal from the examiner. The times when amendment is permitted are restricted to the following occasions: (i) where the applicant has received the initial notice of reasons for refusal and the said amendment is made within the designated time limit for the submission of a written opinion; (ii) where, following the receipt of the notice of reasons for refusal, the applicant has received a notice under Article 48-7 and the said amendment is made within the designated time limit under the said Article; (iii) where, following the receipt of the notice of reasons for refusal, the applicant has received a further notice of reasons for refusal and the said amendment is made within the designated time limit under Article 50 with regard to the final notice of reasons for refusal; and (iv) where the applicant files a request for a trial against an examiner's decision of refusal and the said amendment is made at the same time as the filing of such request.

As for content-wise restriction on amendments, where amendments are made after the applicant has received the initial notice of reasons for refusal from an examiner, in particular where (i) amendments are made in response to the initial notice of reasons for refusal under Article 50 -2 or (ii) amendments are made in response to the subsequent notice of reasons, amendments of the scope of claims that are permitted are limited to: (i) the deletion of a claim or claims; (ii) restriction of the scope of claims (limited to the cases where the restriction is to restrict matters required to identify the invention stated in a claim or claims under Article 36(5), and the industrial applicability and the problem to be solved of the invention stated in the said claim or claims prior to the amendment are identical with those after the amendment), (iii) the correction of errors; and (iv) the clarification of an ambiguous statement (limited to the matters stated in the reasons for refusal in the notice of reasons for refusal). This aims at preventing the interests of third parties from being prejudiced.

#### (6) Registration of patent

Where no reasons for refusal are found for a patent application, or where the reasons for refusal have been removed by a written opinion and/or written amendment submitted after the service of the reasons for refusal, a decision is rendered to the effect that a patent is to be granted (Article 51). When, after an examiner's decision of refusal was rendered, a decision to the effect that a patent is to be granted is rendered in reexamination before trial commenced in response to request for a trial against the examiner's decision of refusal (application *mutatis mutandis* of Article 51 under Article 163 (3)) or when a decision to the effect that a patent is to be granted is rendered in examination (by application *mutatis mutandis* of Article 51 under Article 159 (3)), and subject to the payment of patent fees for each year during the period from the first year to the third year have been paid, a patent right becomes

effective upon registration of its establishment (Article 66 (1) and (2)).

Where the registration of the establishment of the patent right has been effected, the content of the patented invention are published in the patent gazette (Article 66 (3)).

The duration of a patent right expires after a period of 20 years from the filing date of the patent application, rather than the registration date of the establishment of the patent right (Article 67 (1)).

### 3. Patent right

#### (1) Effect of the patent right

The Patent Act defines that “a patentee shall have the exclusive right to work the patented invention as a business” (Article 68(1)).

Here, “as a business” is considered to have a wider meaning of workings excluding those in personal or domestic scopes. The “patented invention” is an invention for which a patent has been granted (Article 2(2)). The technical scope of a patented invention, which is the object of a patent right, shall be determined based upon the statements in the scope of claims (claims) attached to the application (Article 70(1)), and the meaning of the description of the claims are interpreted in consideration of the statements in the description and drawings attached to the application (Article 70(2)).

As for the technical scope of the patented invention, advisory opinion can be sought to the Patent Office (Article 71(1)). However, the opinion has no legal binding force, so that it is considered to be just an expert opinion.

Three types of workings are defined for the patented invention according to the categories of invention (Article 2(3)(i)-(iii)).

① In the case of an invention of a product (including a computer program, etc., the same shall apply hereinafter), producing, using, assigning, etc. (assigning and leasing and, in the case where the product is a computer program, etc., including providing through an electric telecommunication line, the same shall apply hereinafter), exporting or importing, or offering for assignment, etc. (including displaying for the purpose of assignment, etc., the same shall apply hereinafter) thereof (Article 2(3)(i)), (2) in the case of an invention of a process, the use thereof (Article 2(3)(ii)); and (3) in the case of an invention of a process for producing a product, in addition to the action as provided in the preceding item, acts of using, assigning, etc., exporting or importing, or offering for assignment, etc. the product produced by the process (Article 2(3)(iii)).

① Products for the patented invention includes computer program. Then, the production of a product means acts of manufacturing and assembling for a product, and in the case of animals and plants, it means acts of breeding, growing, and cultivation, and in the case of a computer program, it means creating, copying, and installation (Article 2(3)(i)).

In recent years, patent applications for AI (artificial intelligence) are increasing. Since AI is inherently computer program, effect of the patent rights on the AI may cause new problems.

When the product is an object, it is difficult to determine that the repair and replacement of parts fall under the work of the patented invention. A precedent and a part of theories mentioned that total replacement of a patented part and total replacement of main parts corresponding to it fall under the production (Tokyo District Court decision on August 31, 2000 for the “QuickSnap case”, the website of the court). However, in the case of partial replacement, there are some cases mentioning that it doesn’t fall under the production if the effect of exhaustion of a patent right is remained in non-repair parts, except for the case of indirect infringement. In other words, “if the replacement of parts uses a device with exceeding a price paid to a right owner of utility model, it is no longer said to be just a repairing act, but falls under the “production” defined in the Act” (Osaka District Court decision on April 24, 1989 for the “Sand production equipment hammer case” in the Collection of



17

## Tokyo District Court Decision on April 24, 2007 “QuickSnap (Utsurun-desu) Case II”



17

Hitting board of the patented invention and defendant’s hitting board in the “Sand production equipment hammer case”

Hitting board of the patented invention	Product of a defendant

On the other hand, in the case of arguing whether the act of importing recycled ink cartridges is covered with the patent right, the court mentioned that “the used ink tank main body of interest is reused to restore from the state lacking the constitution (constituent features H and K) concerning the essential part of the claimed invention. It is appropriate to recognize that, as for the appellant’s product, a patented product lacking an identical point with the appellee’s product before being processed is newly produced. Thus, enforcement of the patent rights shall not be restricted to the appellant’s product which is produced by using the used ink tank main body of the appellee’s patented product after the license is transferred in Japan by the license holder or transferred in overseas by the Japanese license holder.” Thus, the court showed the opinion that the product is covered with the effect of patent right due to “new production approach“(Supreme Court decision on November 8, 2007 for “Canon ink cartridge case” in civil court reports vol.61 No.8 p.2989)

Canon “ink cartridge” and recycled ink cartridge

## Is the unauthorized production/sale of recycled ink cartridge covered by the patent right?

Genuine product by Canon



Compatible product by recycling manufacturer



Photos taken by Sumida on May 15, 2016

25



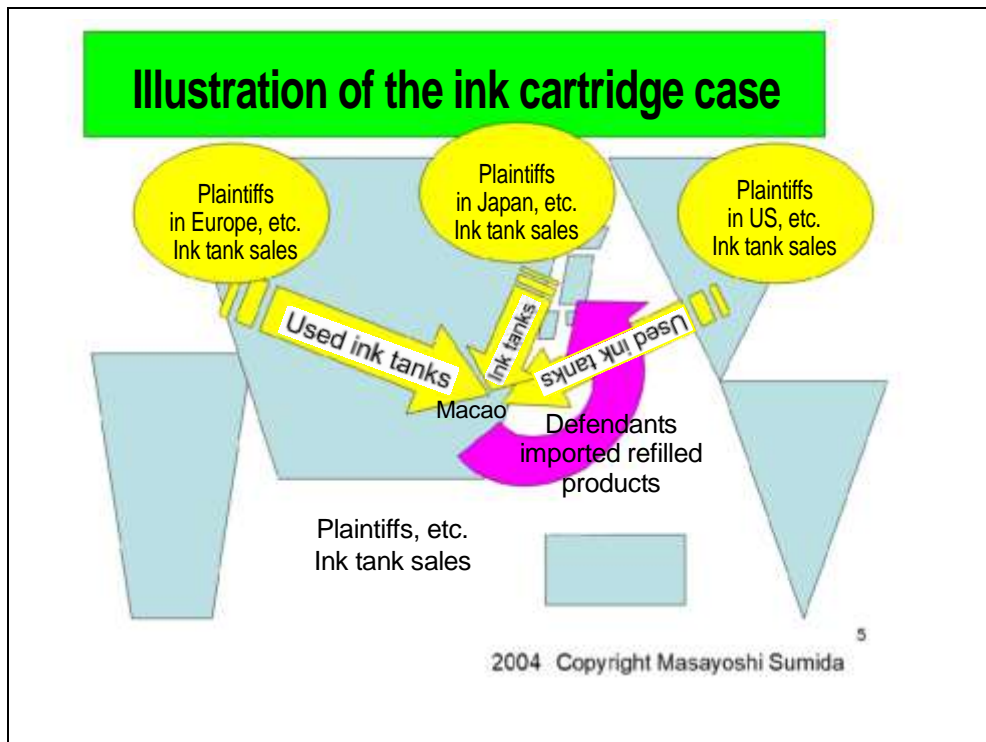

As a new problem, when a patent right holder sells a patented product with retaining ownership of a core tube which is a part of a patented product, “an act of re-rolling new folding paper on the used core tube for commercialization is an act of changing a main member to newly produce the product from a plaintiff’s product whose original service was already finished”. And regarding the question whether the act of producing a product identical to the patented product with using a part of it means the production, the court showed an opinion that it falls under the production (Osaka District Court decision on January 16, 2012 for “Medical folding rolled paper case” reports No.2235 p.93)

Patented invention and patented product in “Medical folding rolled paper case”	原告の特許発明 原告製品（ロールペーパー）
【図3】包装シートの張力調整装置の Patented invention of a plaintiff	Plaintiff's product (rolled paper)
[Fig.3] Schematic block diagram of tension adjustment device for package sheet 制御回路の概略ブロック図	

There is also a case determining that when a component is a part of a patented smartphone but indirectly infringing it, the act of purchasing such component to manufacture a finished product is covered with the patent right (Intellectual Property Court decision on May 16, 2014 for “Apple vs Samsung case” in Law Cases Reports No.2224 p.146).

The use of a product in the patented invention of a product means using it with a method of achieving the purpose of the patented invention (Osaka District Court decision on July 20, 2006 for “Cart fixing device case” in Law Cases Reports No.1968 p.164). If the product is computer program, execution act is the using act.

The assigning, etc. of a product includes provision through an electric telecommunication line such as transmission act, etc. when the product is a computer program, etc., in addition to leasing. This electric telecommunication line is regarded to include all interactive networks.

Exporting means shipment to foreign countries and import means delivery to the Japanese territory, and offering includes displaying for the purpose of assignment, etc.

- ② The working act in a process of a patented invention is just the act of using the process (Article 70(2)). The effect of patent rights concerning an invention of process is not applicable to the sale of the products produced by using the process (Supreme Court decision on July 6, 1999 for “Biologically active substance measurement process case” in Civil Cases Reports Vol.53 No.6 p.957).
- (3) The working act of a patented invention of a process for producing a product includes acts of using, assigning, etc., exporting or importing, or offering for assignment, etc. the product produced by the process, in addition to the act of using the process (Article 70(3)). Here, in the produced products, parent right is applied to the use, sale, etc. of “product at least directly obtained by the process” (refer to TRIPS Agreement Article 28).

(2) Restriction on effect of patent rights



1) Restriction on working of patented invention (use invention)

Even for a patented invention, a patent owner cannot work the patented invention when it uses another person's patented invention, registered utility model, registered design or registered trademark, or when the patented invention is in conflict with design right or trademark right for a three-dimensional trademark (Article 72).

The patented invention having such relations is called as use invention. Use invention entirely contains whole constituent features of another person's patented invention ("look-alike theory": Osaka District Court decision on September 11, 1958 for "Chlorpromazine case" in Law Cases Reports No. 162 p.23. On the other hand, there is a precedent standing on an unavoidable work theory. Though the case is related to design right, the court showed the opinion that "when a design contains all of other registered design or a design similar to other registered design in its constituent features in a manner of distinguishable from other constituent features without impairing the features, use of a design is applicable a relation that a combination of such part and other constituent features causes single design not similar to the other registered design in general, but work of the design inevitably leads to the work of other registered design (Osaka District Court decision on December 22, 1971 for "Study desk case" in Collection of Court Decisions of Intangible Property vol.3 No.2 p.414).

However, to coordinate use invention and a profit for a patent holder of the basic patented invention, compulsory licensing system for allowing requesting for licensing from either party is provided (Article 92).

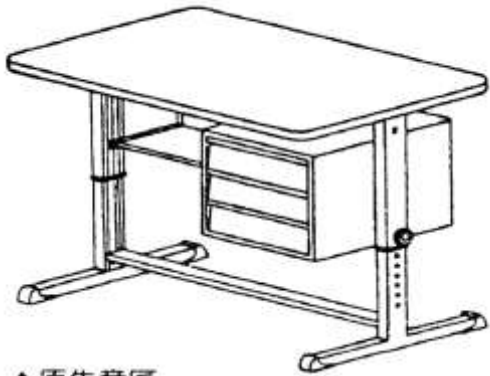
Registered designs of a plaintiff and defendant in "Study desk case"

Plaintiff's registered design(No.284774)	Defendant's registered design (No.284355)
 <p>▲佰生音序</p>	 <p>▲佰生音序</p>

## 2) Statutory restrictions

### i) Work for test/research

Since working of a patented invention for test or research contributes to the technical advancement and development, it accords to the purpose of the Patent Act. Thus, it is not covered with effect of a patent right not so long as profit of a patent owner is impaired (Article 69(1), refer to TRIPS Agreement Article 30).

It can be said that the Patent Act, by nature, allows the working for such test or research. For example, the grant of a patent right is compensation for disclosure of an invention, and this is because the disclosed invention is used for a base of creating new invention for a third party's research and development. In addition to this, when requesting a trial for patent invalidation, violations of enablement requirement, clarity requirement, and support requirement, which are argued in the trial, cannot be proved without conducting tests/researches for determining the effect of the patented invention.

Based on such principle of the patent system, the clinical trial necessary for the manufacture and sale of pharmaceuticals is a test for selling patented products, so that it is difficult to say it is a test/research to enhance new technical development mentioned above. However, a precedent case determined that effect of the patent right is not applicable to the clinical test with two reasons: 1) if the clinical test is covered with effect of the patent right, the test/research should be started after the patent duration is expired, though the test/research is conducted for full-scale manufacture and sale after the expiration, causing the duration of the patent right to be extended for necessary term; and 2) if the product which is approved by clinical tests is manufactured and sold after expiration of the patent right, it is unnecessary to unjustly impair the profit of a patent owner (Supreme Court decision on April 16, 1999 fro "Pancreas disease remedy case) in Civil Cases Reports vol.53 No.4 p.627) .

### ii) International transportation merely passing through

A patent right is not effective against vessels or aircrafts merely passing through Japan, or machines apparatus, equipment or other products used for them (Article 69(2)).

This is because enforcement of patent right should not hinder smooth international traffics, so that vehicles are included in addition to the vessels and aircrafts in Paris Convention Article 22. Though it is difficult to consider vehicles passing into Japan, if technology will develop in the future, it is necessary to make the patent right to be ineffective to the vehicles passing through Japan.

### iii) Other cases that patent right is not effective

The Patent Act lists the following products to which a patent right is not effective.

- (1) Products existing in Japan prior to the filing of patent application (Article 69(2)(ii))
- (2) Act of preparing medicine by a physician or pharmacist and prescribed medicine written in a prescription from a physician or a dentist (Article 69(3))
- (3) Restriction of effect of a patent right restored by late payment of the patent fees (Article 112-3)
- (4) Restriction of effect of a patent right restored by a retrial (Article 175)

### 3) Restriction by statutory non-exclusive license

- i) Non-exclusive license for employers, etc. to employee's invention (Article 35(1))
- ii) Statutory license for the person exploiting the invention in good faith by a request for examination after the term expired (Article 48-3(8))
- iii) Prior use right (Article 79)
- iv) Non-exclusive license due to the working of the invention prior to the registration for patent right transfer (Article 79-2)
- v) The right of interim (Article 80)
- vi) Non-exclusive license after the lapse of design right (Article 81, 82)
- vii) Non-exclusive license to a restored patent right (Article 176)
- viii) Non-exclusive license to a patent right whose duration is extended (1994 Amendment Act supplementary provisions Article 5(2) and (3))

### 4) Restriction by arbitrated license

Non-exclusive licenses admitted by arbitration award have three types: 1) arbitrated license to work own use invention (Article 92), 2) arbitrated license which has not been worked (Article 83), and 3) arbitrated work for public interest (Article 93).

1) and 2) are licenses by a decision of Commissioner of Patent Office, and 3) is a license by a decision of Minister of Ministry of International Trade and Industry, which are called as a compulsory license.

### 5) Exhaustion of patent rights

#### i) Exhaustion in Japan

In the case that effect of a patent right is restricted, exhaustion of a patent right is the most difficult problem in the Patent Act in theory, not to mention in practical work. "Exhaustion" may correct word because the patent right does not extinct in this problem.

Though the principle of exhaustion is applied to all intellectual property rights, only the Plant Variety Protection and Seed Act Article 21(4), Act on the Circuit Layout of a Semiconductor Integrated Circuits Article 12(3), and Copyright Act Article 26-2(2) are legally stipulated. The exhaustion of patent rights, utility model rights, design rights, and trademark rights are just a principle in the case law.

The exhaustion of a patent right is a theory that once a patent owner or a person having license of the patent right legally manufactures and assigns the patented product, the patent right is no longer effective to use, assignment, etc., export and import by a person purchased the patented product.

#### ii) International exhaustion

Though the precedents in Japan accepted the principle of exhaustion, there are different opinions for thorough application of exhaustion in an international context.

The early precedent denied the overseas exhaustion based on the territorial principle. In the case for requesting injunction to a defendant who imported the automatic bowling pin standing device to Japan,

which was manufactured and sold by US patent owner in Australia, the court showed an opinion that “the patent right has a territorial restriction, and a patent right in each country is independent from each other. Accordingly the principle of patent exhaustion should be applicable to the territory of the nation where the patent right has been granted. Thus, even if a case causing exhaustion of the patented product occurred in a nation, it is not reasonable to consider that the patent right in other nation should also be exhausted (Osaka District Court decision June 6, 1969 for “Brunswick case” in Collection of Court Decisions of Intangible Property vol.1 p.160).

On the other hand, almost 30 years after the Brunswick case, in a case of requesting induction and damage compensation to a defendant who parallel imported automobile aluminum wheel manufactured/sold by BBS in Germany, the court showed an opinion that “in regards to the case of a patent owner having a patent right in Japan enforcing the patent right in Japan, if the licensed product is assigned by the patent owner in abroad, the validity of patent right enforcement by the patent owner is a problem of how to interpret the Japanese Patent Act. This problem is irrelevant with the Paris Convention or the principle of territorial (Supreme Court decision on July 1, 1997 for “Final appeal of BBS case” in Civil Cases Reports vol.51 No.6 p.2299). Following to this, the decision admitted international exhaustion that “in the case a Japanese patent owner or the equivalent assigned the patented product in abroad, the patent owner cannot enforce the patent right on the product in Japan except that, for an assignee, agreement was concluded with the assignee to exclude Japan from the countries for selling and using the product, and for a third party assigned the patented product from the assignee or subsequent purchaser, agreement on the above was concluded with the assignee and clearly expressed on the patented product”.

As for final appeal court for this BBS case, there is an opinion that it didn't admit the international exhaustion but the theory of implied implementation is applicable. However, the theory of implied implementation is one of the theories concerning of the grounds of the principle of exhaustion, like as the theories of ownership transfer, achievement of objectives of the right, prohibition of double gains, and it was denied in an early time because it may lead to explicit non-granting of the right, so that it is wrong.

## Points of the BBS case

	First instance	Second instance	Final appellate instance
Relation with the principle of territorial jurisdiction	None	None	None
Domestic exhaustion	Conclusion: Affirmative Reasons: (1) Prohibition of double gains (2) Free distribution of products (safety of transaction)	Conclusion: Affirmative Reasons: (1) Safety of transaction (2) Theory of rewards (3) Prohibition of double gains	Conclusion: Affirmative Reasons: (1) Achievement of purposes (2) Safety of transaction (3) Prohibition of double gains
International exhaustion	Conclusion: Denial Reason: No international agreement	Conclusion: Affirmative Reasons: (1) Prohibition of double gains (2) Theory of rewards	Conclusion: Affirmative Reasons: (1) Implied licensing (2) Safety of transaction

2007 Copyright Masayoshi Sumida

#### 4. Licenses of Patent Rights

##### (1) General Overview

As a property right, a patent right is freely transferrable and hence, may have a mortgage on it. And among other things, the way to use patent rights involves a potent system of licensing. Licenses of patent rights are divided into two types: (a) Exclusive license (Article 77) as an exclusive right as is the case with a patent right; and (b) Non-exclusive license (Article 78).

##### (2) Exclusive License

The term “Exclusive License” refers to an exclusive right to work a patented invention as a business to the extent permitted by the contract granting a license to use the patented invention. The grant of an exclusive license must be registered to take effect (Article 98 (1) (ii)). Its legal nature is a property right which is similar to a land use right as opposed to a possessory title to land.

The grant of an exclusive license shall be subject to limitations on its major terms and conditions, geographical coverage and contents.

An exclusive license has the same effect as that of a patent right in terms of scope. On its own accord, an exclusive license involves a right to seek injunction, a right to seek damages, a right to claim for unjust enrichment and a right to request to take measures to restore credibility (Cf. Articles 100 and 106).

For all the debate about an exclusive licensee’s incontestability with the patentee for the validity of the patent right, the theory should be admissible. The rationale behind this is stated below. Before 2008 in which the Act was amended, the Act had included a provision stipulating that any person may demand a trial for invalidation of a patent. The Amendment to the Patent Act of 2008 precluded any person other than the concerned parties from demanding a trial for invalidation of the patent, and hence, made it difficult to rely on the foregoing provision as the rationale for exclusive licensee’s incontestability. Instead, the argument that there is no rational reason to close the door to a licensee’s being released from obligation to pay royalty on the patent to be invalidated (Decision of the Tokyo High Court of July 30, 1985, Intangible Property Law Cases Reports Vol. 12, No. 2, p. 344, “Faucet Connection Fixtures Design Case”). This is because no patent rights having grounds for invalidation should be allowed to prevent the invention from being worked. However, it should be understood that if the exclusive license agreement includes an incontestability clause, the exclusive licensee’s demanding a trial for invalidation of the patent would constitute a breach of legal obligation or fair and equitable principles.

There were theoretical arguments over whether or not a patentee who granted an exclusive license may seek injunction against a third party who violates its patent right. In the face of expected inability for a patentee who has granted an exclusive license to work the patented invention, court decisions in the past were divided on this issue. Finally, the court ruled that: “(1) There is no grounds in the wording of Article 100 (1) to interpret that the provision precludes a patentee who has granted an exclusive license from enforcing a right to seek injunction; and in real terms, (2) if the license agreement stipulates that the license fee shall be decided based on the sales achieved by the exclusive licensee, the patentee would obviously get actual benefits from eliminating infringement of its patent right from the perspective of securing revenue from license fees; and finally the court held that (3) leaving patent



infringement as it would generally lead to lapse of the exclusive license agreement for any reason, and hence, is likely to be the detriment of the patentee's when it intends to work its patented by itself invention; with these points in mind, it is understood that the patentee should be granted enforcement of a right to seek injunction; taking all the circumstances into consideration, a patentee shall never lose a right to seek injunction even if it grants an exclusive license for use of its patent right." (Decision of the Supreme Court of June 17, 2005, Civil Law Reports Vol. 59. No. 5, p. 1074; "Biological Polymer Case")

An exclusive license may be transferred only where the business involving the working of the relevant invention is also transferred, where the consent of the patentee is obtained or where the transfer occurs as a result of general succession including inheritance (Article 77 (3)).

An exclusive licensee may establish a right of pledge or grant a non-exclusive license on his exclusive license to a third party only where the consent of the patentee is obtained (Article 77 (4)). The grant, transfer (except for a transfer arising from general succession including inheritance), amendment, lapse or restriction on disposition of an exclusive license must be registered to take effect (Article 98 (1) (ii) (iii)). Matters of general succession including inheritance under the preceding paragraph shall be notified to the Commissioner of the Patent Office without delay (Article 98 (2)).

### (3) Non-exclusive License

The term "Non-exclusive License" means a right to work a patented invention as a business to the extent permitted by the contract granting the license to use the patented invention. The grant of a non-exclusive license must be established by a license agreement. Its legal nature is a claim which is said to be similar to a real estate lending right. As shown by a passage of a court decision which reads "A non-exclusive license is 'a mere right to demand the patentee to admit the working of the patented invention stated below' in terms of the scope of right," judicial precedents stand aligned with the theory (The same is true of the Decision of the Supreme Court of April 20, 1973, Civil Law Reports Vol. 27. No. 3, p. 580, "Punching Method Case;" and the Decision of the Osaka District Court of April 26, 1984, Intangible Property Law Reports Vol. 16, No. 1, p. 271, "Frameworks Attachment Bracket Case"). Opinions divided between the doctrine of admissibility (or the doctrine of a right to demand abstention from doing a particular act) and the doctrine of licensing.

The grant of a non-exclusive license shall be subject to limitations on its major terms and conditions, geographical coverage and contents as is the case with an exclusive license.

It is disputed both in judicial precedents and doctrines whether or not a non-exclusive licensee may seek injunction and/or claim damages against a third party infringing the patent right under the license agreement. In a precedent, the court ruled that a non-exclusive license neither involves a right to seek injunction nor a claim for damages (Decision of the Osaka District Court of April 26, 1984, Intangible Property Law Reports Vol. 16, No. 1, p. 271, "Frameworks Attachment Bracket Case").

However, judicial precedents acknowledged that a licensee has a claim for damages under a non-exclusive license (Decision of the Osaka District Court of December 20, 1984, Intangible Property Law Reports Vol. 16, No. 3, p. 803, "Hair Brush Design Case"). In one of these judicial precedents, the court held that a non-exclusive licensee may not exercise a right to seek injunction vested in it (op. cit., "Hair Brush Design Case"). In another precedent, the court held that a non-exclusive licensee may

exercise a right to seek injunction by subrogation into the position of the patentee (Decision of the Tokyo District Court of August 31, 1965, Intangible Property Law Reports Vol. 1, p. 222, “Double Eccentric Cum Device Case”).

In this respect, the doctrine of admissibility is that a non-exclusive licensee may not exercise the right vested in the non-exclusive licensee but that it may exercise the patentee’s right to seek injunction by subrogation into the position of the patentee (Article 423 of the Civil Code). Opinions relying on the doctrine of admissibility argue that a non-exclusive licensee may exercise a right to seek injunction vested in it and hence the right to claim damages on the grounds that an exclusive licensee has a similar legal standing to that of a real estate lessee whose rights under the lease agreement would only become perfect after the real estate is occupied or taken on lease.

As stated in the paragraph headed “Exclusive License” above, it is understood that a non-exclusive licensee shall have no duty of incontestability with the patentee for the validity of the patent right. In the event that a non-exclusive license agreement specifically contains an incontestability clause, it is understood that the non-exclusive licensee’s raising an objection shall constitute a breach of obligation or a breach of fair and equitable principles as is the case with an exclusive license.

A patentee who has granted a non-exclusive license may receive civil relief in the same manner as after the non-exclusive license is registered.

The Amendment to the Patent Act of 2011 abolished the non-exclusive license registration system, thereby perfecting non-exclusive license. With the Amendment, when a non-exclusive license is registered, the non-exclusive license shall have effect on any person who subsequently acquires the patentee or the exclusive licensee, or the exclusive license on the patent right (Article 99). This virtually put an end to a long dispute over a patentee’s duty to cooperate with registering a non-exclusive license.

Under the Act, a patentee has the duty to maintain its patent right in a trial for invalidation of a patent. Where there is a non-exclusive licensee, a patentee may waive the patent right only where the consent of the said non-exclusive licensee is obtained (Article 97). With regard to the question on whether or not a patentee who has granted a non-exclusive license has the duty to eliminate infringements of its patent right, the doctrine of admissibility takes a negative approach while the doctrine of licensing takes a positive approach only where there is a non-exclusive licensee on the grounds that the doctrine of licensing endorses the exercise of a right to seek injunction and claim for damages vested in a non-preferential non-exclusive licensee only where there is a preferential non-exclusive licensee.

With regard to transfer of non-exclusive license, a non-exclusive license may be transferred only where the business involving the working of the relevant invention is also transferred, where the consent of the patentee is obtained and where the transfer occurs as a result of general succession including inheritance (Article 94 (1)) as in the case of an exclusive license. A non-exclusive licensee may establish a right of pledge on the non-exclusive right only where the consent of the patentee is obtained (Article 94 (2)).

The grant of non-exclusive licenses and the creation of pledges over claims shall be governed by and construed in accordance with Article 364 of the Civil Code.

A non-exclusive license shall lapse upon lapse of a patent right, expiration of the term of a license agreement, termination/cancellation or waiver of a license agreement or intermingling of license

agreements.

It is important to note that where there is a pledgee, a non-exclusive licensee may waive the non-exclusive license, only where the consent of the said pledgee is obtained (Article 97 (3)).

## 5. Infringement of a Patent Right

### (1) General Overview

The term “Infringement of a Patent Right” as used herein refers to acts of working a patented invention as a business directly or indirectly by a third party with no legitimate right to do so. The former act is referred to as “Direct Infringement” and the latter “Indirect Infringement.”

The term “Direct Infringement” as used herein refers to acts of working a patented invention in a manner that satisfies all the constituent features written in claims attached to the application (Article 68 and Article 2 (3) (i) through (iii)). The term “Indirect Infringement” as used herein refers to acts of using a patented invention indirectly by taking a part in or by aiding and abetting a third party’s act of working that satisfies all the constituent features of the patented invention. An indirect infringement is a full-fledged form of infringement of a patent right, which shall be subject to civil relief and/or criminal sanctions as is the case with a direct infringement.

### (2) Direct Infringement of a Patent Right

#### 1) Meaning of “Direct Infringement”

The term “Direct Infringement of a Patent Right” refers to acts of working a patented invention in a manner that all the constituent features of the patented invention are satisfied. Not to speak of literal infringement which involves working of a patented invention literally, a direct infringement involves acts of working a patented invention in a manner that all of the constituent features of the patented invention stated in the scope of claims are not satisfied but that a part thereof are replaced with another part. This act of working, as referred to as an infringement under the doctrine of equivalents, is deemed to fall within the technical scope of the patented invention and hence, to be protectable by the patent. In addition, infringements by incomplete working of a patent is included.

#### 2) Literal Infringement of Patent Rights (Claim Interpretation)

The term “Literal Infringement of a Patent Right” refers to acts of working a patented invention exactly as stated in the scope of claims as constituent features of the patented invention. Given that a claim is expressed in language, it would most often involve interpretation of the statements in the scope of claims to determine whether or not an art worked by a third party with no legitimate right to do so would satisfy the constituent features stated in the scope of claims. The efforts so required are referred to as “Claim Interpretation.”

Under the Act, the technical scope of a patented invention shall be determined based upon the statements in the scope of claims attached to the application (Article 70 (1)). Any invention not stated in the scope of claims shall not fall within the technical scope of the patented invention even if it is stated in the description (Decision of the Tokyo District Court of July 21, 1976, Hanrei Taimuzu No. 352, p. 313, “Naphthyridines Manufacturing Process Case”).

Nonetheless, judicial precedents say that in some technical fields such as chemicals and medicines,

a product from a third party's working of a patented invention that satisfies all the statements in the scope of claims may not fall within the technical scope of the patented invention if the product fails to produce an operation/working effect stated in the scope of claims (Decision of the Osaka District Court of October 30, 2001, Hanrei Taimuzu No. 1102, p. 270, "Aerosol Formulation Case"; Decision of the Osaka High Court of November 22, 2010, the court's website "Decision on an Appeal on the Aerosol Formulation Case"). Such a defense is referred to as "Defense of Unsuccessful Production of Operation/Working Effect."

It is a controversial issue whether or not a so-called selection invention as a patented invention with the statements of a matter of selection in the scope of claims could constitute a dependent invention in relation to a prior patented invention and hence, an infringement of the prior patent.

In the case of a patented invention with the statements of a newly discovered use, such as "prophylactic drug," in the scope of claims, the technical scope of the patented invention shall be interpreted not to extend to "therapeutic drug" and hence, does not constitute a literal infringement. However, if the stated use is found to be replaceable with another use, the patented invention shall be interpreted to constitute an infringement under the doctrine of equivalents as will be described later.

In the case of a so-called "functional claim," which refers to a claim that expresses the features contained therein only in terms of functions or operation/working-effect of the product, not in terms of specific constitution of the product, interpreting the claim literally would typically allow it to cover too broad a scope. Therefore, the meaning of each term used in the scope of claims shall be interpreted in consideration of the statements in the description and drawings attached to the application (Article 70 (2)) and the state of the art as at the time of filing an application (Decision of the Tokyo District Court of December 22, 1998, Law Cases Reports No. 1674, "Magnetic Media Reader Case").

In the case of a so-called "product-by-process claim," which refers to a claim that does not state the construction or constituents of the product but the method of manufacturing of the product in the scope of claims, despite the fact that it states that the patented invention is an invention of product in the scope of claims, judicial precedents used to be based on the following claim interpretations: (a) In the event that the claim is included in the scope of claims because of the difficulty of clearly articulating the construction or constituents of the product (or in the case of a true product-by-process claim), the defendant's product which is identical with that of the plaintiff's would infringe the patent right in/to the latter even if the former is made by a different method from that of the plaintiff's; and (b) In the event that the claim is included in the scope of claims despite the possibility of clearly articulating the construction or constituents of the product (or in the case of a untrue product-by-process claim), the defendant's product which is made by a different method from that of the plaintiff's would not infringe the patent right in/to the latter even if the former is identical with that of the plaintiff's (Decision on an appeal to the grand panel of the Intellectual Property High Court of January 27, 2012, Civil Law Reports Vol. 69. No. 4, p. 822; "Pravastatin Sodium Case"). To put it simply, court decisions used to be oriented toward the method of manufacturing with respect to claim interpretation.

As a matter of fact, the decision of a hearing of an appeal to the Supreme Court recites, "In the

event that a patent is granted on an invention of product, the effect of the patent shall extend to any product whose constitution, characteristics, etc. are identical with those of the product, regardless of the method of manufacturing by which it is made.” (Decision of the Supreme Court of January 27, 2015, Civil Law Reports Vol. 69. No. 4, p. 700 and p. 904; “The Hearing of an Appel to the Supreme Court on the Pravastatin Sodium Case”). To put it simply, court decisions have become oriented toward the identity of product.

### 3) Materials for Claim Interpretation

Materials used for claim interpretation should consider the statements in the description and drawings attached to the application (Article 70 (2); Decision of the Supreme Court of May 27, 1975, Law Cases Reports No. 781, P. 69, “The Hearing of an Appel to the Supreme Court on the Oar Case” and others).

It is questionable that some juridical precedents on identification of a claimed invention held that the statements in the description attached to the application may only be considered under exceptional circumstances, such as in the case wherein the meaning of the technical terms used in the statements in the scope of claims is not directly and unambiguously derivable from the statements in the scope of claims (Decision of the Supreme Court of March 3, 1991, Civil Law Reports Vol. 45. No. 2, p. 123, “Lipase Case”).

A term used in the statements in the scope of claims shall be interpreted to be used in a meaning in which the term is commonly used and in a unified meaning throughout the statements in the description attached to the application and the scope of claims unless otherwise defined (Refer to the Ordinance for Enforcement of the Patent Act, Article 24-4, Form No. 29-2, Recital 9).

It is important to note that statements in the abstract attached to the application shall not be taken into consideration (Article 70 (3)).

Other materials for claim interpretation include the state of the art (or publicly known art) as at the time of filing an application and publicly available prosecution history. The rationale for allowing for taking into consideration the state of the art as at the time of filing an application is that a patented invention inherently provides the basis for granting an exclusive right in/to an invention which meets the requirements for patentability based on the state of the art as at the time of filing the application (or publicly known art).

However, in the case of a patented invention which is totally in the public domain, opinions are split between ones oriented toward claim interpretation based on a restricted technical scope and ones denying an infringement of the patent right without relying on interpretation of the technical scope. Opinions for claim interpretation based on a restricted technical scope are further split between ones oriented toward literal interpretation of the statements in the scope of claims (Decision of the Matsuyama District Court of February 25, 1974, Intangible Property Law Cases Reports Vol. 6, No. 1, p. 46; “Metallic Rack Case”) and ones oriented toward limiting the technical scope to working examples (Decision of the Osaka High Court of February 10, 1976, Intangible Property Law Cases

Reports Vol. 8, No. 1, p. 85; “Metallic Mesh Basket Case” and others).

In this case, there used to be an argument that the patent should rightfully be invalidated. However, judicial precedents eventually determined that in the presence of obvious grounds for invalidation of a patent, acts of filing a demand for an injunction or claim for damages would constitute an improper use of a right (Decision of the Supreme Court of April 11, 1999, Civil Law Reports Vol. 54. No. 4, p. 1368; “Kilby Case”).

As a result of this decision on the Kilby Case, the court ruled, in 2004, that where, in litigation concerning the infringement of a patent right or an exclusive license, the said patent is recognized as one that should be invalidated by an invalidation trial, the rights of the patentee or exclusive licensee may not be exercised against the adverse party (Article 104-3).

Acceptance of such a patent invalidity defense would not warrant its effectiveness against third parties but would only be binding on the parties concerned. Given that the objective of this defense is to accelerate a conflict resolution over the patent right, where a patent invalidity defense is submitted for the purpose of unreasonably delaying the proceedings, the defense would be dismissed (Article 104-3 (2); Decision of the Supreme Court of April 24, 2008, Civil Law Reports Vol. 62, No. 5, p. 1262; “Knife Machining Equipment Case” shall apply to a counterargument to a written answer).

Legal acceptance of such a virtual patent invalidity defense caused the “Double-track” situation under the Patent Act where the invalidity of a patent is determined both by the Patent Office and the court and these authorities sometimes rendered a different decision from each other, thereby warranting the necessity to resolve the differences of decisions between the authorities. The Amendment to the Patent Act of 2011 imposed a restriction on making a plea for a conclusive and final appeal/trial decision of invalidation in a retrial after a judicial decision has become final and binding.

The rationale for considering prosecution history in claim interpretation is that a patentee may not make a claim which contradict representations made by the patentee in the process of following the procedure for obtaining a patent right and that in this case the patentee may be subject to the doctrine of file wrapper estoppel.

A relevant judicial precedent involves an appeal trial in which there are statements in the scope of claim that read “A rice cake with a slit(s) not on the upper surface but on the sides thereof” and, in the prosecution of proceedings, the defendant offered an opinion to the effect that the rice cake of the invention has a slit(s) on the sides thereof in an effort to resolve reasons for refusal/rejection; however, the court ruled that the defendant’s rice cake with a slit(s) on the upper surface and on the sides thereof fall within the technical scope of the patented invention, taking into consideration the fact that the defendant took back its opinion (Decision of the Intellectual Property High Court of September 7, 1991, Law Case Reports, No. 2144, p. 121; “Hearing of Appeal on the Sato’s Rice Cake Case”).



2010年12月1日角田撮影

**Interlocutory Judgement of the Intellectual Property High Court of September 7, 2011, Law Case Reports, No. 2144, p. 121; “Hearing of Appeal on the Sato’s Rice Cake Case”**

**Echigo’s rice cake**



**Sato’s rice cake under the trade name of “Parrito-Suritto”**



© Photograph taken by Sumida on December 1, 2010

22

4) Patent Infringement by Equivalents (Doctrine of Equivalents)

The doctrine of equivalents is a legal theory under which an invention worked by a person should be deemed to be identical with another person’s patented invention in terms of underlying technical idea and hence, to constitute an infringement of the patent right if the worked invention produces the same operation/working effects as those of the patented invention although the worked invention has a part of the constituent features stated in the scope of claims replaced with different constituent features (replaceability) and if a person skilled in the art could have easily arrived at the idea of replacing as at the time of infringement (the easiness to make replacement and to arrive at the idea of replacing) (Decision of the Osaka District Court of April 2, 1969, Intangible Property Law Reports Vol. 4, No. 1, p. 354, “Hook and Loop Fastener Case”).

The doctrine of equivalents has been developed as a theory of infringement in the U.S. and Germany. In Japan, opinions have been long divided on its applicability and applicable requirements in terms of judicial precedents and theoretical base.

On February 24, 1998, the Supreme Court however squarely accepted the doctrine of equivalents (Decision of the Supreme Court of February 24, 1998, Civil Law Reports Vol. 52. No. 1, p. 113, “Ball Spline Case”).

The doctrine of equivalents appears in two different forms: One is based on the holistic view that the Patent Act is precisely based on the doctrine of equivalents; and the other is based on the exception



view that the Patent Act makes an exception for the doctrine of equivalents.

In a judicial precedent under the holistic-view-based doctrine of equivalents, the court held that “with respect to the manner of finding the technical scope of an invention, the Patent Act takes it for granted that an art of an invention should be found to be an equivalent of the patented invention even if the art does not literally meet the statements in the scope of claims (Decision of the Osaka High Court of March 29, 1996, Intellectual Property Law Cases Reports Vol. 28, No. 1, p. 77; “Hearing of Appeal on the t-PA Case”).

In contrast, the Supreme Court adopted the exception-view-based doctrine of equivalents in the case stated above. This involved an increase in the number of requirements for application of the doctrine of equivalents from two as used to be to five. Specifically, the court in the Ball Spline Case held as follows:

“Even if, within the construction as stated in the scope of claims in the patent specification, there is a part which is different from the products which are produced by another person or the manner adopted by this person, if (i) this part is not the essential part of the patented invention and (ii) the purpose of the patented invention can be achieved by replacing this part with a part in the other person's product and (iii) an identical function and effect can be obtained if a person skilled in the art could easily come up with the idea of replacing at the time of the production of the said products, (iv) if the products are not identical to the technology in the public domain at the time of the patent application of the patented invention or could have been easily conceived by this person at that time, and (v) if there were no special circumstances such as the fact that those products had been intentionally excluded from the scope of the patent claim in the patent application process, such products should be regarded as identical with the construction as stated in the scope of patent claim and fall within the technical scope of the patented invention.

It follows from this court decision that judicial decisions have changed the basis for application of the doctrine of equivalents from the two-requirement theory (the replaceability and the easiness to arrive at the idea of replacing) as used to be to the five-requirement theory.

The five requirements for application of the doctrine of equivalents shown in the decision on the Ball Spline Case include: (i) The replaced part is not the essential part of the patented invention; (ii) The purpose of the patented invention can be achieved by replacing this part with a part in another person's product; (iii) The easiness to make replacement as at the time of infringement; (iv) The art worked by the defendant is not a publicly known or available art; and (v) there were no special circumstances such as the fact that those products had been intentionally excluded from the scope of the patent claim in the patent application process.

Of these five requirements, those under items (i) through (iii) represent positive allegations the plaintiff should make, and those under items (iv) and (v) represent negative allegations the defendant who intends to deny the applicability of the doctrine of equivalents should make.

Some foreign academic theories raise questions about the inclusion of the requirement for applicability of the doctrine of equivalents under item (i) above. In Japan, recent judicial precedents

dared to say that “when determining whether a part which is different from the products that are produced by another person is the essential part of the patented invention or not according to the first requirement for applicability of the doctrine of equivalents, constituent features of the patented invention as stated in the scope of claims should be first divided into the essential part and the non-essential part and then, it should be determined whether the alleged product has the essential part of the patented invention in common or not..., instead of denying any constituent features that fall under the essential part as an equivalent, and if the part which is different from the products that are produced by another person is determined to have the essential part in common, the part should be determined not to be the essential part of the patented invention.”

Illustration of Patented Invention (in the Upper Part) and Defendant’s Product (in the Lower Part) in the Ball Spline Case

**Decision of the Supreme Court of February 24, 1998,  
Civil Law Reports Vol. 52. No. 1, p. 113,  
“Hearing of Appeal to the Supreme Court on the Ball Spline Case”**

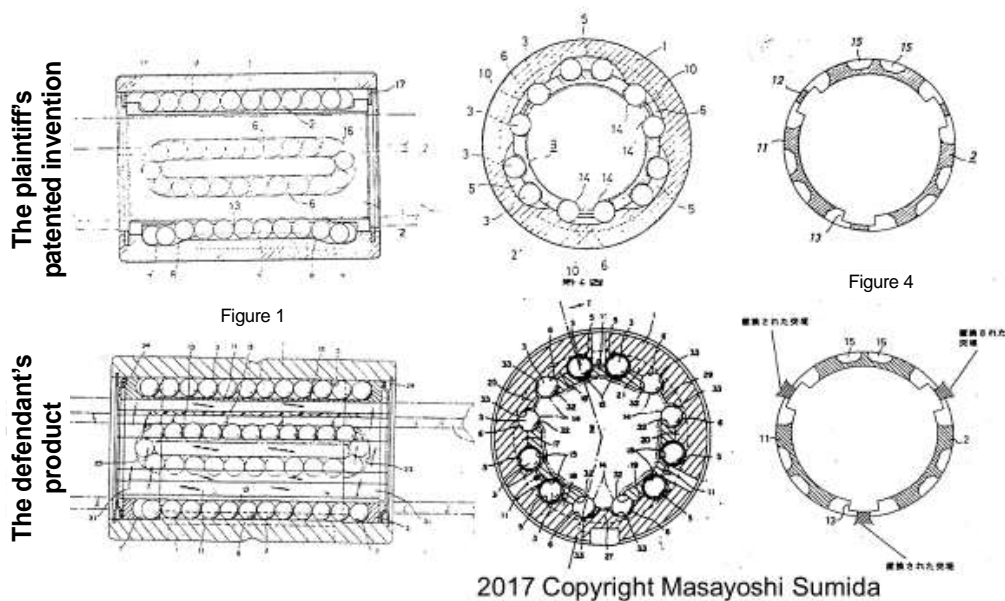

5) Patent Infringements by Incomplete Working

The theory of incomplete working is a legal theory that acts of working a patented invention by a third party with no legitimate right to do so in such manner that minor constituent elements of the patented invention are omitted from the working only to produce a product with reduced working/operation effects relative to that which would have been produced by working the patented invention completely should be deemed to constitute a form of utilization of the patented invention for

all that and hence, an infringement of the patent right.

The theory of incomplete working originates with “Unvollkommene Benutzung” as a German-born theory of patent infringement which was introduced and prevails in Japan. However, it is important to note that the German version of the theory of incomplete working may involve approval of a Defense of Unsuccessful Production of Operation/Working Effect.

In a relevant judicial precedent, the court held, relying on the theory of incomplete working, that “Acts of working a utility-model-registered device by a third party in such manner that minor constituent features of the device are specifically omitted from the working only to produce a product that is similar to the working example of the device but has no beneficial effects other than reduced working/operation effects relative to that which would have been produced by working the device completely is nothing less than the use of the technical idea involved in the device with harmful features added to the constituent features of the device and hence, infringe the scope of protection of the device” (Decision of the Osaka District Court of May 17, 1984, Lower Court Civil Law Reports Vol. 19, Nos. 5 & 6, p. 303, “Toy Blocks Case”).

Some academic theories position the theory of incomplete working as an example of cases subject to the doctrine of equivalents which should be found acceptable as is the case in the doctrine of equivalents. In a recent judicial precedent, the court held that “where a product manufactured by the opposing party lacks a part of the constituent features of a patented invention ... and where the part is not the essential part of the patented invention and satisfies other requirements for the application of the doctrine of equivalents, the product can constitute an infringement under the doctrine of equivalents.” (Decision of the Intellectual Property High Court of October 11, 2012, the Court’s website, “Hearing of an Appeal on the Soft Vinyl Figure Case”)

Illustration of Registered Utility Model and Defendant's Product in the Toy Block Case

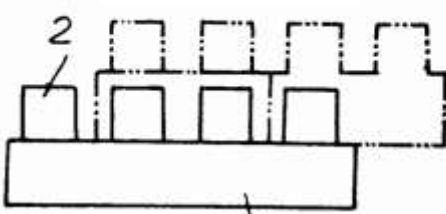
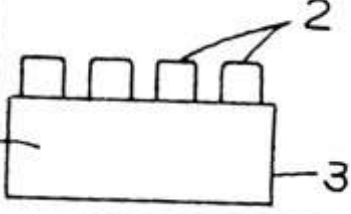
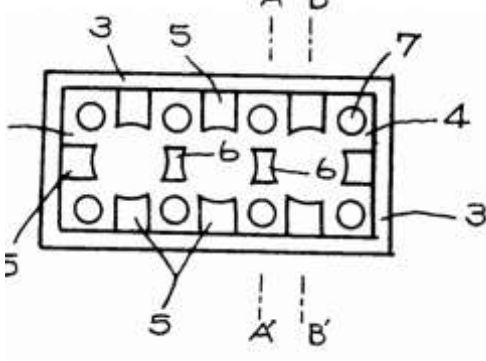
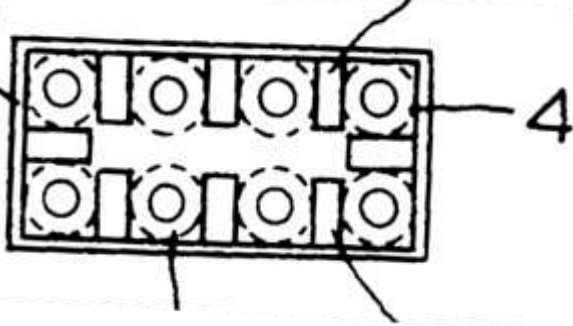
Registered utility model	Defendant's product
<p style="text-align: center;">2 Figure 2</p> 	<p style="text-align: center;">Front view</p> 
	

### (3) Indirect Infringement of a Patent Right

#### 1) Meaning of Indirect Infringement

The term "Indirect Infringement of a Patent Right" refers to acts of joining with or aiding a third party in a plot that would constitute a direct Infringement of a patent right. Indirect Infringement of a Patent Right is a separate form of infringement from that of direct infringement.

It follows that many documentary reports' description of an indirect infringement as a preliminary or preparatory step of a direct infringement is not precise. Although having said that, the Trademark Act has a mix of preliminary or preparatory step of a direct infringement and indirect infringement in Article 37 which is recognized as a clause stipulating conditions for indirect infringements of a trademark right.

By the same token, some experts' argument that in the presence of a direct infringement, the alleged infringement should not so much be deemed to constitute an indirect infringement but a contributory infringement to the direct infringement might not be precise, either.

The rationale behind the incorporation of indirect infringement in the provisions of the Patent Act is that indirect utilization of a patented invention, or any act of joining with or aiding a third party in a plot that would constitute a direct infringement of a patent right should be prohibited to ensure the effectiveness of a patent right.

In particular, where the end user of a patented product is a person exploiting the invention for a private purpose or for a test/research purpose, acts of selling to such end user parts and materials for the

manufacturing of the patented product and apparatuses and equipment for utilizing the patented process could only be prohibited under the legal principle of indirect infringement.

It is within this context of history that the legal principle of indirect infringement has emerged and developed in the context of judicial precedents to ensure protection of a patentee's rights in Germany.

The U.S. quasi-counterpart of indirect infringement is contributory infringement. Given the fact that the U.S. Patent Act stipulates that working of a patented invention for private purpose shall be deemed to constitute an infringement of a patent right, the injured party is always free to hold the alleged party to account. Therefore, properly speaking, there exists no legal principle of indirect infringement.

It should be noted that the provisions of Article 101 of the Patent Act of Japan concerning indirect infringement center on constructive infringement (Article 101 (i), (ii), (iv) and (v)). The Amendment to the Patent Act of 2006 placed acts of possessing a product for whose invention a patent has been granted for the purpose of assigning, etc. or exporting it as a business in the category of constructive infringement (Article 101 (iii) and (vi)). These acts have nothing to do with indirect infringement.

## 2) Indirect Infringement by Exclusive Products

The primary requirement for a finding of indirect infringement by exclusive products is that where a patent has been granted for an invention of a product, the object produced or otherwise made by a third party should be products to be used exclusively for the use of the object and that where a patent has been granted for an invention of a process, the object produced or otherwise made by a third party should be products to be used exclusively for the use of the process.

It is important to note that the Amendment to the Patent Act of 2002 had programs, etc. included in the definition of object, thereby having acts of creating, reproducing and otherwise producing programs included in the definition of production of the object.

As it has been in the past, the definition of the term "products to be used exclusively for ..." matters. From economic, commercial and practical perspectives, judicial precedents and academic theories use it as criteria whether or not the products have any other use.

For example, in case of a patented invention relating to "An execution method of bonding a decorative board to the whole surface of a section of wall to be bonded with characterized by that the decorative board is perfectly bonded to the whole surface of the wall section by driving a nail which includes a pillar-like pressure bonding member made of synthetic resin-based elastic material in between," the court found that that such "a nail which includes a pillar-like pressure bonding member made of synthetic resin-based elastic material in between" is an "exclusive product" which has no other use (Decision of the Osaka District Court of February 16, 1979, Intangible Property Law Cases Reports Vol. 11, No. 1, p. 48, "Decorative Board Case").

That having been said, it should be determined whether or not an object falls under "products to be used exclusively for ...," considering all the circumstances, including, but not limited to, the purpose for which the object was produced, the nature of the product and the business conditions in which the product is traded. Seen in that light, apart from the subjectivity requirement, there may have been little

need for the Patent Act to include a new provision concerning indirect infringement by exclusive products which will be discussed in the following section.

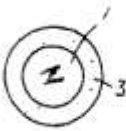
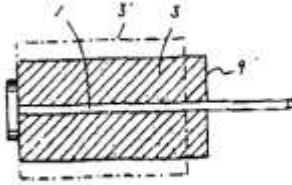
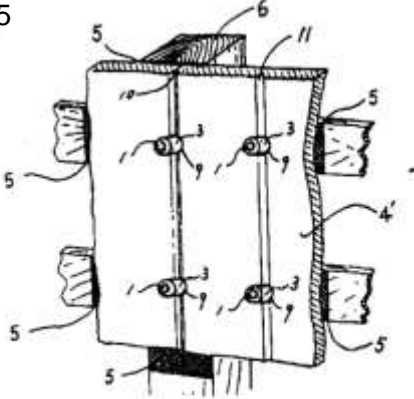
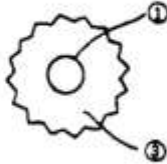
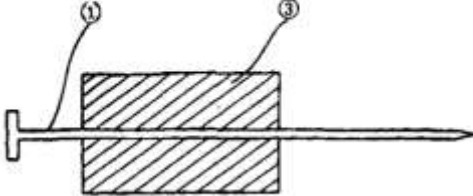
Patented invention	Defendant's product
<p data-bbox="268 477 368 510">Figure 1</p>  <p data-bbox="603 470 703 504">Figure 2</p>  <p data-bbox="256 752 357 786">Figure 5</p> 	<p data-bbox="991 465 1139 499">Drawing (a)</p>  <p data-bbox="1015 763 1115 797">Figure 1</p>  <p data-bbox="995 1133 1096 1167">Figure 2</p>

The second requirement for a finding of indirect infringement by exclusive products is that acts of producing, assigning, etc., importing or offering for assignment, etc. any “product to be used exclusively for ...” must have taken place.

The reason why indirect infringements do not include acts of using any “product to be used exclusively for indirect infringements is that use of such a product would constitute a direct infringement. The reason why indirect infringements do not include acts of exporting such a product is thought to be that acts of working a patented invention abroad would not constitute a direct infringement under the principle of territoriality. Acts of assigning, etc., any “product to be used exclusively for ...” includes acts of offering programs, etc. through telecommunication lines.

In terms of requirements for a finding of indirect infringement, it comes into question whether a direct infringement needs to have occurred or not. Although literal interpretation of Article 101 of the Patent Act does not clearly answer the question, it is understood that a patented invention has been or is likely to be worked directly. In this respect, the academic theories have been split between the so-called theory of independence and the one of dependence. Under the so-called theory of dependence saying that an indirect infringement could not be established with absence of direct infringement, it would

become impossible to preclude a person exploiting the invention for a private purpose from getting supplies of parts, etc. In a judicial precedent, the court held that where an act of replacing parts by the end user is deemed to constitute a direct infringement, an indirect infringement would be established, relying on the theory of dependence (Decision of the Osaka District Court of October 24, 1989, Intangible Property Law Reports Vol. 21, No. 1, p. 279, “Sand Making Machine Hammer Case”). In another judicial precedent, the court held that acts of assigning the product constitute an indirect infringement to the defendant’s family but that acts of assigning the product to a person who works a patented invention abroad does not constitute an indirect infringement (Decision of the Osaka District Court of October 24, 2000, Hanrei Taimuzu No. 1081, p. 241, “Bakery Equipment Case”).

These precedents indicate that a finding of an indirect infringement does not involve the subjectivity requirement.

<b>Bakery Equipment in the Bakery Equipment Case</b>	
<p>Bakery equipment using “bread-making method” of a patented invention</p>	
	<p><b>1: Yeast cells    2: Ingredients for bread</b>  <b>3: Bread container</b>  <b>4: Moving vane for mixed kneading</b>  <b>5: Control part    9: Bakery equipment body</b>  <b>10: Oven</b></p>

### 3) Indirect Infringement by Non-Exclusive Products

The provisions of the Patent Act concerning indirect infringement by non-exclusive products were included in the Act by the Amendment to the Act of 2002. Unlike in the case of indirect infringement by exclusive products, the subjectivity requirement have been included in the provisions.

That having been said, the provisions concerning indirect infringement by non-exclusive products are the same in content as those originally contained in the report for legislation of the law now in force.

The first requirement for finding of indirect infringement by non-exclusive products is that the object produced or otherwise made by a third party should be products to be used for the use of the object, regardless of whether exclusively or non-exclusively and that where a patent has been granted for an invention of a process, the object produced or otherwise made by a third party should be

products to be used for the use of the process, regardless of whether exclusively or non-exclusively, and that these products should be a necessary item for solving the problem to be solved by the patented invention.

The term “products necessary for solving the problem to be solved by the patented invention” is defined as those products other than the constituent features of the invention (features identifying the invention), ranging so far as utensils, raw materials, etc., which shall be used for the production of the product or for the use of the process, albeit based on a different concept from that of the constituent features of the invention.

For example, where the patented invention relates to a rubber-erasable ballpoint pen, the particular kind of pigment used for its ink falls under “a necessary item for solving the problem to be solved by the patented invention” while a long-existing penholder or cap of the ballpoint pen does not fall thereunder.

In regard to this point, in a patent infringement case on a pharmaceutical product comprised of a combination of medical drug A and medical drug B in which the defendant who only manufactures and sells medical drug A was accused of an indirect infringement, the court ruled that “An item representing a constituent feature of the patented invention which has been long required without relation to the problems to be solved by the invention does not fall under ‘a necessary item for solving the problem to be solved by the patented invention’” (Decision of the Tokyo District Court of February 25, 2013, the court’s website, “Pioglitazone Tokyo Case”), only to find, however, a total lack of products that fall under the category of indirect infringement.

By the same token, the Amendment to the Patent Act of 2000 had programs, etc. included in the definition of the object, thereby not only allowing acts of selling a program (e.g. “Ichitaro” as a word-processing program) which would fall within the scope of claims of the patented invention if installed on a computer to be deemed to constitute an indirect infringement (Decision of the Intellectual Property High Court of September 30, 1985, Intangible Property Law Cases Reports Vol. 12, No. 2, p. 344, “Faucet Connection Fixtures Design Case”), but also allowing acts of creating, reproducing, selling, etc. programs used for creation, reproduction and selling of the product to be deemed to constitute an indirect infringement.

However, it should be noted that the products producing, selling, etc. of which shall be deemed to constitute an indirect constitute exclude staple articles, such as screws, nails, light bubbles, transistors which are widely distributed in Japan.

The second requirement for indirect infringement by non-exclusive products is that acts of producing, assigning, etc., importing or offering for assignment, etc. any “product to be used non-exclusively for the use or ...” must have taken place.

The third second requirement for indirect infringement by non-exclusive products is the subjectivity requirement. The person performing the alleged act must know that the invention is a patented invention and that the object is used for use of the patented invention.

The subjectivity requirement is careful not to hold well-intentioned suppliers of parts, etc. legally



liable for indirect infringement. Suppliers of parts, etc. who did not know the facts by negligence shall not be exempt from its application.

A finding of indirect infringement by non-exclusive products does not involve the occurrence of a direct infringement.

Illustration of Patented Invention and Defendant's Ichitaro in the Ichitaro Case

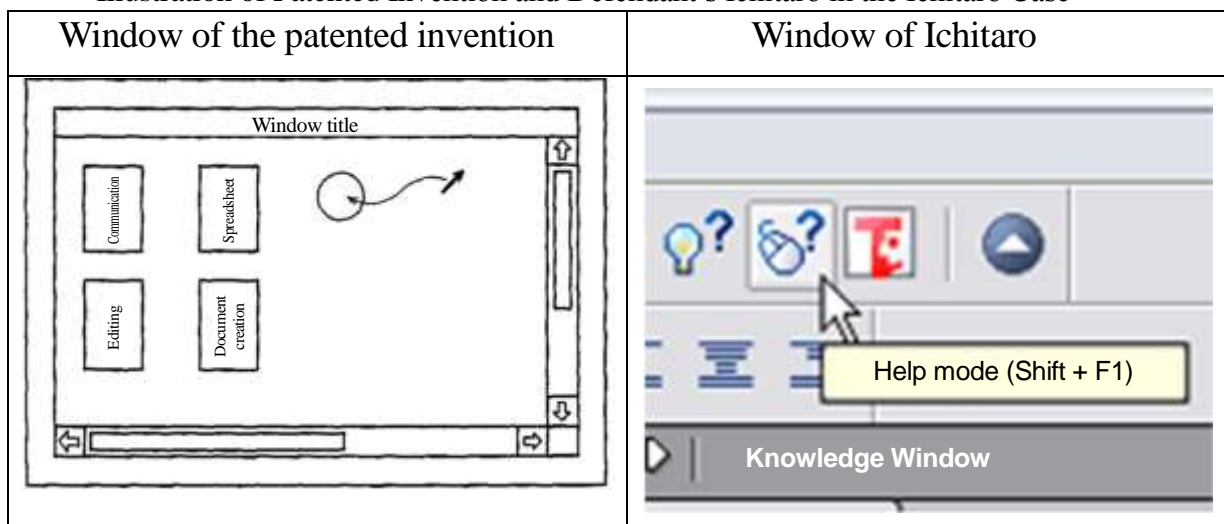

#### (4) Civil Relief against Patent Infringements

##### 1) Right to Seek Injunction

A patentee or exclusive licensee may demand a person who infringes the patent right or exclusive license to stop such infringement as is the case with a property-based claim in an infringement of the right of ownership (Article 100).

The intent and purpose of the right to seek injunction is to stop or prevent such infringement (Article 100 (1)). In making a demand under the preceding paragraph, the patentee or exclusive licensee may demand measures necessary for the prevention of such infringement including the disposal of products constituting such act of infringement and the removal of facilities used for the act of infringement (Article 100 (2)).

In contrast to a claim for damages, a right to seek injunction does not require a finding of an infringement by intention or negligence to invoke and may be exercised to stop or prevent an actual or potential infringement. In many cases, an order of provision disposition is requested in addition to an action for compensation for damage (Article 23 of the Civil Provisional Remedies Act).

##### 2) Claim for Damages

A person who has intentionally or negligently infringed a patent right of others shall be deemed to have committed a tort and shall be liable to compensate any damages resulting in consequence under Article 709 of the Civil Code.

Requirements for a finding of claim for damages include: (a) Legal competency; (b) Either on purpose or by design; (c) Infringement of right (illegality); (d) Occurrence of damages; and (e) Reasonable causal relationship between the infringement of right and the occurrence of damages (Article 709 of the Civil Code).

The Patent Act includes provisions concerning presumption of negligence (Article 103) and provisions concerning presumption of amount of damage, etc. (Article 102) in view of the nature of infringement of patent right, thereby facilitating the exercise of right holder's right to seek damages.

#### (5) Criminal Sanctions against Patent Infringement

An infringer of a patent right or exclusive license who has committed an act that shall be deemed to constitute direct infringement shall be punished by imprisonment with work for a term not exceeding ten years or a fine not exceeding 10,000,000 yen or combination thereof (Article 196).

Any person who has committed an act that shall be deemed to constitute indirect infringement shall be punished by imprisonment with work for a term not exceeding five years or a fine not exceeding 5,000,000 yen or combination thereof (Article 196-2).

Where a representative of a juridical person or an agent, employee or other worker of a juridical person or an individual has committed in the course of performing his/her duties for the juridical person or individual, any act in violation prescribed in the following items, in addition to the offender, the juridical person shall be punished by a fine not exceeding 300 million yen (Article 201).

## 6. Litigation Rescinding Appeals, Trials or Trial Decisions Concerning the Patent Right

### (1) Outline

If there is a flaw in the result of examination of a patent application by the Patent Office, it would injure interests of not only the patent applicant and patentees but also third parties.

In order to correct such fault, the Patent Act provides a system of appeal and trial as quasi-judicial measures of the Patent Office. As proceedings concerning patents require high-level knowledge and related judgments often are binding legal effectiveness as to third parties, the government from the beginning decided to entitle the Patent Office, an expert agency of the patent rights, to make judgements on patent-related proceedings.

The type of trial and appeal includes a trial or an appeal against an examiner's decision of refusal (Article 121) and the correction trial (Article 126), which are the examiner's decision-oriented trial, and the trial for patent invalidation (Article 123) and the trial for invalidation of a registration of extension of duration (Article 125-2), which are parties-oriented trial.

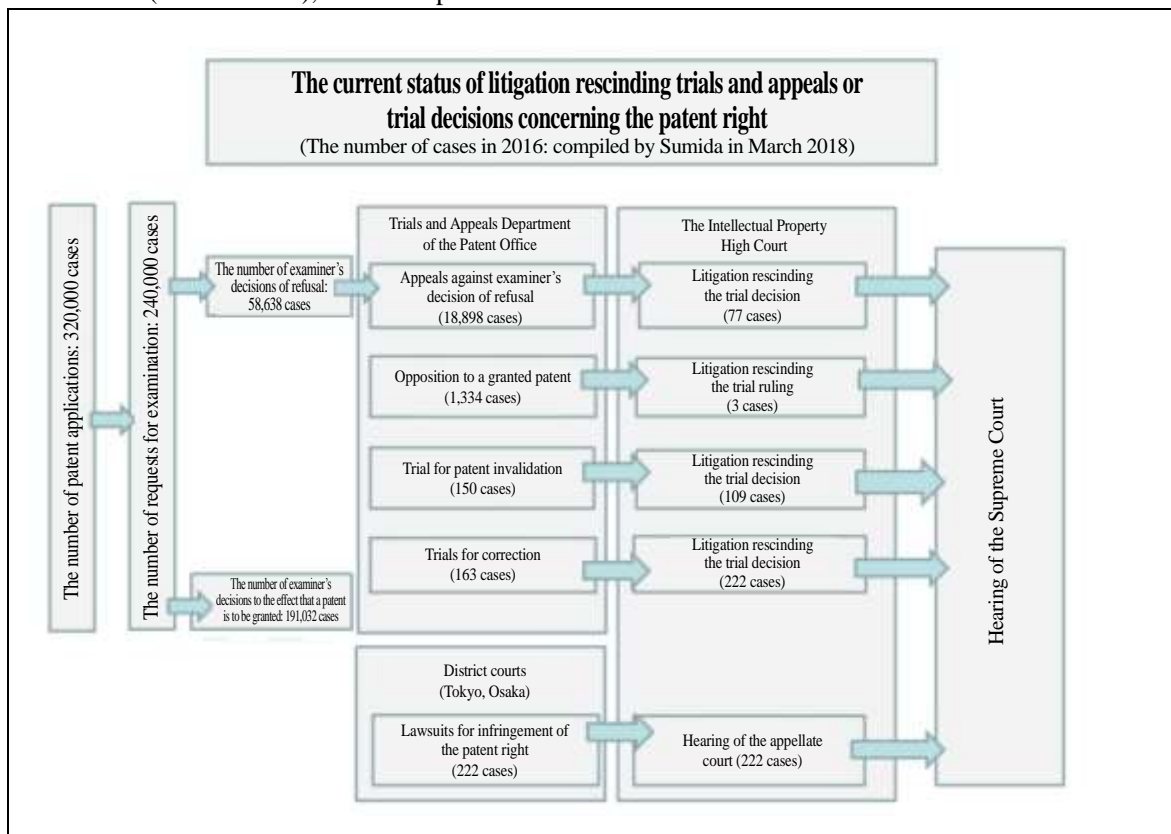

## (2) Appeals against Examiner's Decision of Refusal:

### 1) The Purpose of the System:

The examiner of the Patent Office shall notify an applicant for a patent (Article 50) of reasons for refusal of the patent application (each Item of Article 49). If the applicant is unable to eliminate such reasons of the refusal by submitting a written opinion or written amendment, the examiner shall render an examiner's decision to the effect that the patent application is to be refused (the introductory clause of Article 49).

An applicant who is dissatisfied with the examiner's decision of refusal may file appeal against the examiner's decision within three months from the date the certified copy of the examiner's decision has been served (Article 121 (1)). As there is no demandee in appeals against the examiner's decision of refusal, it is called the examiner's decision-oriented trial.

A person who may file appeal against the examiner's decision of refusal is the one who has received the decision to the effect that the patent application is to be refused. In the event that a patent right is jointly owned, all of the joint owners shall jointly file the request for appeal (Article 132 (3)). This is because an appeal decision needs to be determined in a single form for all the joint owners.

In appeal trial, it shall not be deliberated whether the examiner's decision of refusal is appropriate but the deliberation shall focus on whether the applied patent should be granted or not.

### 2) Reconsideration by Examiner Before Appeal:

An applicant for a patent may amend the application at the same time of filing a request for an appeal against the examiner's decision of refusal (the proviso under Article 17-2 (1)). In the event that an amendment has been made to the application at the time of filing the request, the Commissioner of the Patent Office shall direct the examiner to examine the request prior to proceedings by a panel of administrative judges (Article 162). This is the system called the reconsideration by examiner before appeal, which is designed to expedite the examination process. The system allows the examiner to reexamine an application from which the reasons for refusal have been eliminated by amendment; thereby, granting a patent to the application.

In the event that the examiner judges that the decision of refusal is no longer maintained due to the amendment, the examiner shall rescind the decision of refusal and render a decision to the effect that a patent is to be granted (Article 164 (1)). If the examiner judges that the decision of refusal can be maintained, the examiner shall report to the Commissioner of the Patent Office the result of the examination (Article 164 (3)). Following the report, the process shall move on to an appeal. The examiner may not render a decision to the effect that the patent application is to be refused for the second time against the applicant, which is an adverse disposition to the applicant.

### 3) Proceedings and Trial Decisions:

Appeals against examiner's decision of refusal shall be conducted by a panel consisting of three or five administrative judges designated by the Commissioner of the Patent Office (Article 136 (1)).

Appeal against examiner's decision of refusal is characterized as a rehearing of the examination and any procedure taken during the examination procedure shall also be effective in appeal against an examiner's decision of refusal (Article 158). Proceedings in appeal shall be conducted in principle by documentary proceedings; provided, however, that the chief administrative judge may, upon a motion by the party or ex officio, decide to conduct the trial by oral proceedings (Article 145 (2)). In addition, Fact finding and examination of evidence by the court's own authority is adopted, in which not only the appropriateness of the examiner's decision of refusal but also any grounds not pleaded by a party or intervenor may also be examined in the trial (Article 153 (1)). For this reason, evidence may be actively examined or preserved in the trial (Article 150) and ex officio proceedings is adopted (Article 152).

As a result of the proceedings, if it was determined that maintaining the examiner's decision of refusal is appropriate, the court shall render a trial decision of refusal to the effect that the request for appeal was invalid. On the contrary, if it was determined that the examiner's decision of refusal cannot be maintained, the court shall render a trial decision to the effect that the request for appeal was valid and a patent is to be granted (Application mutatis mutandis of Articles 51 in accordance with Article 159 (3)). In the event that administrative judges found reasons for refusal different from the examiner's decision of refusal, the demandant who filed the request for appeal shall be notified of the reasons for refusal as in the case of examination (Article 163 (2)).

In appeal, an examiner's decision of refusal can be rescinded and appeal decision may be made to order a further examination to be carried out (Article 160 (1)). In this case, the decision made in the appeal decision shall be binding upon the examiner with respect to the case (Article 160 (2)).

A person can file a request for appeal against examiner's decision of refusal concerning an application for registration of extension of the duration of a patent right.

### (3) Trial for Patent Invalidation

#### 1) The Purpose of the System:

Despite invalid reasons for a patent right, keeping such patent valid shall cause significant damage to industries and free competition.

For this reason, the Patent Act introduces the system of invalidation trial that eliminates invalid patents erga omnes (Article 123).

Since parties concerned contest in invalidation trial, it is called the concerned parties-oriented trial.

#### 2) Reasons for Invalidation:

The following eight are legally defined reasons for invalidation (each Item of Article 123 (1)). In the event of two or more claims, a request for invalidation trial may be filed for each claim:

i) The patent has been granted on a patent application with an amendment in which new matters were added in violation of Article 17-2 (3);

(ii) The patent has been granted in violation of the following provisions: Enjoyment of rights by foreign nationals (Articles 25); Industrial applicability, novelty and progressivity (Article 29);

Expansion of the scope of prior application (Article 29-2); Unpatentable inventions (Article 32); Joint applications (Article 38); or Principle of prior application (Article 39 (1) to (4));

iii) The patent has been granted in violation of a treaty;

iv) The patent has been granted on a patent application that did not satisfy practices in enablement requirements of a detailed explanation of the invention (Article 36 (4) (i)) or requirements for the statement of the scope of claims (Article 36 (6) excluding 36 (6) (iv));

v) When matters stated in the description, scope of claims or drawings attached to the foreign-language-written-application are not within the scope of matters stated in foreign-language-documents. In other words, the patent was applied for the scope outside the original foreign-language-documents.

vi) The patent has been granted on a patent application filed by a person who has not had the right to obtain a patent for the said invention. In other words, the patent has been granted to a misappropriated application. However, even though the application was misappropriated, in the event that the patent right is transferred to and registered with the person who is entitled to obtain based on a request in accordance with Article 74 (1), the reasons for invalidation shall be deemed to be remedied; thus, does not constitute invalidation.

vii) After a patent was granted, the patentee has become unable to hold a patent right in accordance with the provision for the enjoyment of rights by foreign nationals (Article 25), or the patent has become in violation of a treaty; and

viii) When the correction of the description, scope of claims or drawings attached to the application for the patent were made in violation of the purpose of correction (Article 126 (1) proviso or Article 134-2 (1) proviso) or the conditions for correction (Article 126 (5) – (7) including the application *mutatis mutandis* of Article 134-2 (9)).

### 3) Request for Invalidation Trial:

A request for invalidation trial may be filed only by an interested person (Article 123 (2)). However, if a patent was granted in violation of the provision of the joint application (Article 38) or the patent has been granted to the misappropriated application (Article 123 (1) (vi)), only the person who has the right to obtain the patent may file a request for an invalidation trial.

A request for invalidation trial may be filed even after the lapse of the patent right (Article 123 (3)). This is because the right to claim damages against the patentee for the act of infringement committed while the patent was valid can be maintained even after the lapse of the patent right.

### 4) Request for Correction in Invalidation Trial:

In response to request for invalidation trial by a third party, the patentee, in order to maintain the patent right by eliminating reasons for invalidation, may correct matters stated in the description, scope of claims or drawing(s) only within a certain period of time while proceedings of the invalidation trial is in progress (Article 134-2 (1) main clause).

Only the demandee of the invalidation trial is allowed to file a request for correction. However, in the event that there is an exclusive licensee, non-exclusive licensee, a pledgee, non-exclusive licensee of inventions by employees or non-exclusive licensee by grant, the consent of the said person is required (Application *mutatis mutandis* of Article 127 in accordance with Article 134 (9)).

Such correction shall be limited to (1) restriction of the scope of claims; (2) correction of errors in the description or of incorrect translations; (3) clarification of an ambiguous description, and (4) correction of a statement of claims which cites other statement of claims to the statement which does not cite the said other statement of claims (Article 134-2 (1) proviso).

#### 5) Effects of Proceedings and Trial Decisions:

Proceedings of an invalidation trial are in principles oral and open proceedings. When the trial is pending, the patentee may not file a request for correction trial subsequently described (Article 126 (2)) but instead may file a request for correction in an invalidation trial (Article 134 (1)).

When a trial decision to the effect that a patent is to be invalidated has become final and binding, the patent right shall be deemed never to have existed (Article 125). However, after a patent right was granted, if the patentee becomes unable to enjoy the patent right in accordance with the provision for the enjoyment of rights by foreign nationals (Article 25) or the said patent has been granted in violation of a treaty, the patent shall be deemed not to have existed from the time of the said item first became applicable to the patent (Article 125 proviso).

With the revision of the Patent Act in 2011, the system of notifying a trial decision in advance was introduced. Under this system, when the case of invalidation trial has reached the point at which a trial decision may be rendered, the chief administrative judge shall, where he or she finds a reasonable ground for request for a trial, shall notify the parties and the intervenors of an advance notice of the trial decision. When an advance notice of a trial decision is notified, the chief administrative judge shall designate to the defendant an adequate time limit for filing a request for correction (Article 164-2).

In order to prevent a request for invalidation trial on the same matter from being repeated, when a trial decision became final and binding in an invalidation trial, neither parties nor intervenors may file a request for a trial on the basis of the same facts and evidence (Article 167). This is called a “prohibition against double jeopardy.”

#### (4) Correction Trial

##### 1) The Purpose of the System:

The correction trial is a trial in which the patentee, after a patent was granted and registered, may file a request for correction trial with regard to the correction of matters stated in the description, scope of claims or drawings (Article 126).

If the whole patent was decided to be invalid for such partial fault in a patent that part of scope of claims applied for the patent includes a technology known to the public or the description is ambiguously stated, it would be overly stringent to the patentee.

A patent with faulty description or scope of claims may make the scope of patent right ambiguous. In order to avoid detrimental effects of such faulty patent on a third party, the correction trial was introduced as a means for patentees to counter an invalidation trial.

The correction trial is an examiner's decision-oriented trial as there is no adverse party.

## 2) Demandant of Correction Trial:

The patentee may file a request for correction trial (Article 126 (1)). In the event that the patent right is under joint ownership, all of the joint owners shall jointly file a request (Article 132 (3)). This is because a decision needs to be determined in a single form for all the joint owners.

If there is an exclusive licensee, a pledgee, a non-exclusive licensee of inventions by employees or a non-exclusive licensee by grant, the patentee may file a request for a correction trial for correction only with the consent of the said person (Article 127). This is because corrections may affect all of the said person. However, these people are deemed not to be obligated to give consent (Tokyo District Court ruling rendered on April 28, 2004 reported on Law Cases Report No. 1866, page 134 "The case of demanding deregistration of non-exclusive licensee).

A request for correction trial may be filed even after the lapse of the patent right (Article 128 (8)). Provided, however, that this shall not apply: (1) after the patent has been revoked in revocation decision or invalidated in invalidation trial; and (2) from the time invalidation trial has become pending to the time the trial decision has become final and binding (Article 126 (2)).

## 3) Requirements for Correction Trial:

Purposes of correction shall be limited to (1) restriction of the scope of claims; (2) correction of errors in the description or of incorrect translations; (3) clarification of an ambiguous description, and (4) correction of a statement of claims which cites other statement of claims to the statement which does not cite the said other statement of claims.

In a correction trial, it is prohibited to add new items as prohibited in amendment (Article 126 (5) and the patentee may not substantially enlarge or alter the scope of claims (Article 126 (6)).

Corrections for the purpose of the preceding (1) and (2) shall satisfy requirements for independent patentability (Article 126 (7)).

When a trial decision to the effect that requested corrections are approved has become final and binding, the effect of the decision shall retroact to the time of the application and the application for the patent shall be deemed to have been made based on the corrected description, scope of claims from the beginning (Article 128). In the event of requesting corrections of the scope of claims covering two or more claims, the patentee may request a correction trial for each claim (Article 126 (3)).

When a trial decision to the effect that the prohibition of adding new claims, substantial enlargement or altering the scope of claims or violation of independent patentability has become final and binding, the patent shall be invalidated (Article 123 (1) (viii)).



## (5) Opposition to a Granted Patent

### 1) The Purpose of the System:

When a patent is granted and registered, the patentee shall have the exclusive right to work the patented invention (Article 68 (1)), but it cannot necessarily be said that examinations of patentability by the Patent Office are infallible.

As such, the Patent Office provides an opportunity for public examination with respect to patentability for the patented right after granting.

An opposition to a granted patent is a public examination in which any person may file to the Commissioner of the Patent Office an opposition to each claim of a granted patent within six months from the issuance of the gazette containing the patent (Article 113). This is because granting an exclusive patent right to an application that does not satisfy patentability requirements shall disturb the order of business and violate principles of justice

### 2) Reasons for Opposition to a Granted Patent:

The following are reasons for opposition to a granted patent, some of which overlap with reasons for refusal or reasons for invalidation but a misappropriated application, unlike reasons for refusal and reasons for invalidation, is not included:

- ① The patent has been granted on a patent application (excluding a foreign-language-written-application) with an amendment that does not comply with the requirements as provided in Article 17-2 (3);
- ② The patent has been granted in violation of Article 25, 29, 29-2, 32 or 39 (1) to 39 (4);
- ③ The patent has been granted in violation of a treaty;
- ④ The patent has been granted on a patent application not complying with the requirements as provided in Article 36 (4) (i) or 36 (6) (excluding (iv)); and
- ⑤ Matters stated in the description, scope of claims or drawings attached to the foreign-language-written application are not within the scope of matters stated in foreign-language-documents.

### 3) Procedures:

While a trial for patent invalidation is conducted by oral proceedings, an opposition to a granted patent is conducted by documentary proceedings (Article 118 (1)).

In the event that multiple motions of an opposition to a granted patent related to the same patent right, a panel of trial shall put together all reasons for opposition and proceedings shall be in principle jointly conducted (Article 120-3). Proceedings shall be conducted by a trial panel. Only when the chief administrative judge intends to render a revocation decision, the judge shall notify the patentee of the reasons therefor and give the patentee an opportunity to submit a written opinion and make corrections (Article 120-5 (1)). If the patent is corrected in the process, the demandant may submit opinions (Article 120-5 (5)).

If the patentee is dissatisfied with a revocation decision, the patentee may institute a lawsuit with the

Intellectual Property High Court (Article 178 (1)). Unlike a trial for patent invalidation, the demandant of opposition to a granted patent may not institute a lawsuit against a decision to maintain the patent in question (Article 114 (5)).

#### (6) Litigation Rescinding the Trial Decision

##### 1) Outline:

Litigation rescinding the trial decision is a lawsuit in which court, which is the judicial organization, makes judgement on a trial decision made by the Patent Office, which is an administrative agency.

The Tokyo High Court shall have exclusive jurisdiction over any action against a revocation decision or a trial decision, a ruling to dismiss a written request for an opposition to a granted patent, a trial or a retrial (Article 178 (1)). Specifically, the Intellectual Property High Court, a special branch of the Tokyo High Court, shall handle these matters (Article 2 of the Act for Establishment of the Intellectual Property High Court).

##### 2) Appropriate Party in the Case

Plaintiffs of litigation rescinding the trial decision shall be limited to those who received a revocation decision or a trial decision, a decision to dismiss a request for amendment in trial, a ruling to dismiss a written request for an opposition to a granted patent or a trial or a retrial, or a successor of these actions, an intervenor or a person whose application for intervention in the proceedings has been refused (Article 178 (2)).

When a request for a trial is filed by a joint owner or owners of a patent right or a right to obtain a patent, all of the joint owners shall jointly file the request (Article 132 (3)); however, there is no such provision is set for litigation rescinding the trial decision.

Under the circumstances, it has been discussed whether litigation rescinding the trial decision is a compulsory joinder in which all of joint owners are required to jointly institute a lawsuit or non-compulsory joinder in which a single joint owner is allowed to institute a lawsuit as a means of preservation.

A judicial precedent for this matter requires a compulsory joinder, which needs a single form decision for all the joint owners in an appeal against a ruling of maintaining examiner's decision of refusal in a trial against an examiner's decision of refusal, which is the examiner's decision-oriented trial (The Supreme Court ruling rendered on March 7, 1995 reported in the civil case judicial precedents (Minshu) Volume 49, Item 3, page 944 "Magnetic induction therapy apparatus case").

Another judicial precedent states that an appeal against an examiner's decision of invalidation in a trial for patent invalidation is a non-compulsory joinder, in which a single joint owner is allowed to institute a lawsuit as means of preservation (The Supreme Court ruling rendered on February 22, 2002 reported in the civil case judicial precedents (Minshu) Volume 56, Item 2, page 348 "ETNIES trademark case," the Supreme Court ruling rendered on February 28, 2002 reported in the Law Cases

Report No. 1779, page 81 “Mizusawa udon (wheat noodle) trademark case,” <Case concerning trademark>.

The Commissioner of the Patent Office shall be the defendant in litigation rescinding the trial decision including such examiner’s decision oriented trial as an appeal against an examiner’s decision of refusal, an appeal against an examiner’s decision in a trial for correction, an appeal against the decision of dismissal in opposition to a granted patent, an appeal against the decision of dismissal of written request for an opposition to a granted patent or a request for a trial or retrial (Article 179 (1)).

However, in the case of an action against a trial decision in a trial for patent invalidation, or a trial for invalidation of the registration of extension of duration, or in a retrial against a final and binding trial decision in such trials, the demandant or the demandee in the trial or retrial shall be the defendant (Article 179 (1) proviso).

### 3) The Time Limit for Institution of Action:

An action may be instituted within 30 days from the date on which the ruling or a certified copy of the trial decision has been served. The time limit shall be invariable (Article 178 (3) (4)). The chief trial examiner may ex officio designate an additional period extending the invariable time limit for a person in a remote area or an area with transportation difficulty.

### 4) Proceedings and the Scope of Proceedings

Litigation rescinding the trial decision is a judicial review by the Intellectual High Court, which shall hear a case as a fact-finding proceeding of the first trial.

In litigation rescinding the trial decision, the high court will examine whether the fact-finding of evidence, which was used as facts and reasons for the basis of the trial decision, and the judgment displayed in the trial decision based the facts, were appropriate.

The scope of proceedings shall be solely limited to facts and evidence, which were argued in the proceedings of the first trial and used for making the judgment.

A judicial precedent in an invalidation trial did not admit reasons for invalidation as a result of comparison with a new fact known to the public, which had not been used in reaching the trial decision (The Supreme Court ruling rendered on March 10, 1976 reported in the civil case judicial precedents (Minshu) Volume 30, Item 2, page 79 “The meias knitting machine case”).

However, in order to clarify the significance of the prior art exhibited in evidence and examined in the first trial, it shall be allowed to recognize the technical common practice of a person skilled in the art at the time of application for a patent by using data as supporting evidence, which did not appear in the proceedings of the first trial (The Supreme Court ruling rendered on January 24, 1970 reported in the civil case judicial precedents (Minshu) Volume 34, Item 1, page 80 “The food packaging container case”).

5) Ruling:

If the court, as a result of proceedings, finds for the defendant that there is no ground for the request for the trial, it shall dismiss the request. On the contrary, if the court finds for the plaintiff that there is a reasonable ground for the request for the trial, it shall rescind the trial decision or ruling (Article 181 (1)) and the ruling of rescinding the trial decision shall be binding on the administrative agency and any other relevant administrative agency with regard to the case (Administrative Case Litigation Act Article 33 (1)).

When the court's ruling rescinding a trial decision or ruling has become final and binding, the administrative judges shall carry out further proceedings and render a trial decision or ruling (Article 181 (2)).

— End —