



Comparative Case Study on Disclosure and Claims

JEGPE 2013-2014

This report is used for research purposes only.

Contents

I. Introduction	1
II. Results of Case Studies	
1. Case 1(KIPO selection in 2013)	
1.1 Overview of the Invention	2
1.2 Examination Results	4
2. Case 2(JPO selection in 2013)	
2.1 Overview of the Invention	12
2.2 Examination Results	14
3. Case 3(SIPO selection in 2013)	
3.1 Overview of the Invention	17
3.2 Examination Results	20
4. Case 4(KIPO selection in 2014)	
4.1 Overview of the Invention	31
4.2 Examination Results	32
5. Case 5(JPO selection in 2014)	
5.1 Overview of the Invention	36
5.2 Examination Results	40
6. Case 6(SIPO selection in 2014)	
6.1 Overview of the Invention	42
6.2 Examination Results	43
III. Summary of results and analysis	- 47 -

I. Introduction

Joint Expert Group for Patent Examination (JEGPE) project was established in 2009 in order to promote patent cooperation among JPO, KIPO and SIPO. The trilateral offices conduct a comparative study on patent laws and examination guidelines and a comparative case study on a selected topic every year, so the users can deeply understand the examination standards on their practices and prepare high quality patent applications. So far, JEGPE has conducted comparative study on inventive step, novelty, disclosure and claims, and the protection of utility models.

The study reports has been published such as the reports of Comparative Study on Patent Laws and Examination Guidelines for Inventive Step (2010), Novelty (2012), Disclosure and Claims (2013), and the reports of Case Studies for Inventive Step(2011), and Novelty (2012).

For the case study on Disclosure and Claims, each office proposed two cases separately, and three cases were studied in 2013, and others were studied in 2014.

The three offices evaluated the selected cases whether these are met the requirement for disclosure and claims according to each office's examination guidelines and practices. The e offices also had a discussion on the result of the case study as well as the differences in t he examination of the requirement for disclosure and claims.

II. Results of Case Studies

1. Case 1 (KIPO selection in 2013)

1.1 Overview of the invention

(1) Title : DRUG CONTAINING CHYMASE INHIBITOR AS THE ACTIVE INGREDIENT

(2) Claims

[Claim1]

A drug for improving glucose intolerance comprising a chymase inhibitor as an active ingredient

[Claim 2]

A preventive drug and/or therapeutic drug of diseases caused by glucose intolerance comprising a chymase inhibitor as an active ingredient

[Claim8]

A drug described according to any of claims 1-7 wherein the chymase inhibitor is the compound represented by formula (I):

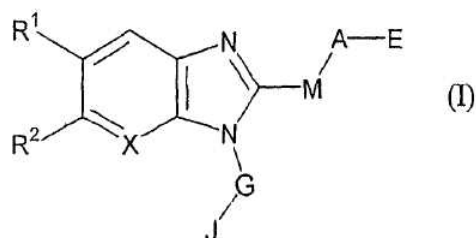

(3) Summary of the description

The present invention provides drugs containing chymase inhibitors as active ingredients for improving glucose intolerance or preventing and/or treating diseases caused by glucose intolerance.

The diseases caused by glucose intolerance are diabetes and/or diabetes complications, wherein the diabetes complications include diabetic nephropathy, diabetic retinopathy, diabetic peripheral neuropathy, hyperinsulinism, insulin resistance syndrome, arteriosclerosis, acute coronary syndrome, arteriosclerosis obliterans, angitis, stroke, hypertension, renal insufficiency, nephropathy, nephritis, renal artery aneurysm, renal infarction, obesity and the like.

Drugs in the present invention use chymase inhibitors as active ingredients.

Chymase inhibitors used in the present invention are, although not particularly limited,

preferably the benzimidazole derivatives or medically acceptable salts thereof described in WO 01/53291, WO 01/53272 and WO 00/03997.

Any compound that inhibits human chymase activity may be used as a chymase inhibitor in the present invention. Specifically, it is the chymase inhibitor with an IC_{50} value, determined by method (A) for IC_{50} assay described below, of preferably 1000 nM or less, more preferably 500 nM or less, further preferably 100 nM or less, still further preferably 10 nM or less.

A group of 22 weeks-old wild type mice (C57Black) (Wild), a group of those in which human chymase gene was expressed (TGM) and a group of TGM that had been given feed containing 0.1% sulfate of compound 58 (the IC_{50} value of compound 58 is between 1 nM and 10 nM) as a chymase inhibitor (ChI) continuously for 12 weeks since 10 weeks old (TGM/ChI) were made fast overnight and orally administrated with 1.5 g/kg glucose. At 60 min after glucose load the concentrations of glucose and insulin in blood were assayed.

At 60 min after glucose load, the blood glucose levels were 119 ± 20 mg/dl for Wild, 181 ± 22 mg/dl for TGM and 134 ± 18 mg/dl* for TGM/ChI (mean \pm SD, * $p < 0.01$ vs. Wild, $p = 0.01$ vs. TGM), indicating that the blood glucose level after glucose load significantly increased in TGM and that administration of ChI significantly repressed the increase.

It has been found that, compared with the wild type mice, mice in which human chymase gene is expressed exhibit significantly high values of the blood glucose level and the blood insulin concentration, showing that the glucose intolerance is caused by the expression of human chymase. It has also been shown that administration of a chymase inhibitor remarkably reduces the blood glucose level and the blood insulin concentration, improving glucose intolerance. Accordingly, it is clear that chymase inhibitors used in the present invention are inhibitors against human chymase that can be clinically applicable to inhibiting and/or treating various diseases associated with glucose intolerance induced by human chymase.

The description disclosed "Any compound that inhibits human chymase activity may be used as a chymase inhibitor in the present invention. Specifically, it is the chymase inhibitor with an IC_{50} value, determined by method (A) for IC_{50} assay described below, of preferably 1000 nM or less, more preferably 500 nM or less, further preferably 10 nM or less". The example 1 of description also disclosed "the IC_{50} value of compound 58 is between 1 nM and 10 nM".

Reference for detail description: KR 10-2006-120601 A1, US 2007/032466 A1,
JP 4387360 B2, CN 1871029 A

1.2 Examination Results

Three offices compared the examination results under the following several conditions 1 to 7.

1.2.1 Condition 1

Claims 1 and 2 set forth a drug. "A drug" may be construed as a pharmaceutical compound or a pharmaceutical composition. The question is how to define the subject matter of these claims, a compound or a composition?

(1) JPO Analysis

A drug described in Claim 1 and 2 is recognized as a composition. In the claim 1 and 2, chymase inhibitor is described as an active ingredient. "Active ingredient" suggests the existence of some kinds of inactive ingredients included in the claimed drug.

(2) KIPO Analysis

According to the expression form of claims in a pharmaceutical invention disclosed in Chapter 7 of the Examination Guideline of Medical Drug/Cosmetics, a use invention whose purpose is medical drugs shall be described in the form of a product and as an example, the chapter contains 'a pharmaceutical composition for treating disease B, comprising compound A as an active ingredient'. In other words, the expression form of a pharmaceutical purpose is to consist of active ingredient A of a pharmaceutical composition and pharmaceutical purpose B of a pharmaceutical composition. On the other hand, an invention on 'compound A for treating disease B' is deemed not to claim a pharmaceutical purpose, but to claim 'compound A'. (Explanation of 2.1 Expression Form of Pharmaceutical Invention of Chapter 7 of Examination Guideline of Medical Drug/Cosmetics). The inventions in claims 1 and 2 disclose the claims starting with the term 'drug' and therefore, can be interpreted as a compound or pharmaceutical composition. However, the pharmaceutical purpose of 'for improving glucose intolerance' and the active ingredient of 'comprising a chymase inhibitor as an active ingredient' are disclosed and therefore, the inventions in claims 1 and 2 can be deemed as composition inventions claiming the pharmaceutical purpose of a chymase inhibitor.

(3) SIPO analysis

In SIPO, the subject matter "drug" is considered to be clear, which can be interpreted as either "compound" or "composition". When the characterizing portion expresses that the "drug" consists of single compound as the sole component, "drug" indicates compound. While, if the characterizing portion expresses that the "drug" consists of compound and other adjuvant materials, "drug" indicates composition.

1.2.2 Condition 2

"Improving glucose intolerance" in claims 1 and 2 can be considered as a feature of use. The question is whether such feature would further restrict the scope of product claim. Is the protection scope regarded as second medical use of known compounds "chymase inhibitor", or the product per se, i.e. a drug containing "chymase inhibitor"?

(1) JPO Analysis

The protection scope is a second medical use of known compounds. "Chymase inhibitor" itself is well known, but the use of the ingredient for improving glucose intolerance is patentable. The second medical use is not considered lack of novelty, simply because the compound is known.

(2) KIPO Analysis

As analyzed in the above-mentioned [Condition 1], the inventions in claims 1 and 2 are deemed to claim the pharmaceutical purpose of improving glucose intolerance of a chymase inhibitor, not the chymase inhibitor itself. Therefore, 'improving glucose intolerance' is deemed to specify the pharmaceutical purpose of the disclosed compound of chymase inhibitor and the scope of the patent protection is considered to be limited to the purpose of improving glucose intolerance of chymase inhibitor.

(3) SIPO analysis

Firstly, claims 1 and 2 can be considered as a kind of product claim defined by feature of use. The actual definitive effect of the feature of use is determined by whether the feature of use in claims 1 and 2 implies that the claimed product has a certain particular structure and/or composition or not. The scope of claims 1 and 2 are essentially products. Generally, SIPO would prefer to search for a reference document which discloses a drug containing chymase inhibitor and presenting the same or different medical use. Because the feature of use does not imply that the claimed product has a certain particular structure and/or composition, it is deduced that the claims 1 and 2 do not possess novelty. For example, reference document 2 (CN1418211A) discloses the drug containing chymase inhibitor. Reference document 1 (WO0222595A1) discloses that chymase inhibitor relates to the use for treating diabetes mellitus. Reference document 1 and 2 can separately destroy the novelty of claim 1 and 2.

1.2.3 Condition 3

Is the expression "chymase inhibitor" regarded as functional definition? Shall the provision of clarity or provision of sufficient supporting be applied?

(1) JPO Analysis

"Chymase inhibitor" is regarded as a functional definition. This definition includes a lot of active ingredients having a function to inhibit chymase. Compare with the detailed description, this functional definition is overly expanded from disclosed actual inventions in this patent application. Therefore, there is a problem of support requirement. "Chimase inhibitor" itself is considered clear, because it is considered that chymase inhibitor means ingredients inhibiting chymase.

(2) KIPO Analysis

Since a person skilled in the art can understand that the active ingredient of the composition refers to a compound with the effect of chymase inhibition, the description of the active ingredient as chymase inhibitor is deemed to satisfy the provision of the clarity requirement. ([19], [147], [275], etc. of Detailed Description of Invention) However, where the active ingredient is functionally described as in the inventions in claims 1 and 2, since compounds

with such functions all constitute a chymase inhibitor, all compounds yet to be developed containing the effect of chymase inhibition contain the active ingredient. If allowed, the scope of right would be excessively set and such compounds cannot be recognized to have the effects similar to those of the compounds in the embodiments. Therefore, the examiner shall notify the applicant of the ground for rejection under Article 42(4)(i), citing that the claims are not supported with the detailed description of the invention.

Along with the notification, the examiner may notify another ground for rejection under Article 42(3) of the Patent Act that in the detailed description of the invention, the functional expression of the chemical structure, manufacturing process and pharmaceutical effects of the active ingredient is not easily described enough for a person skilled in the art to work the claimed invention.

The detailed description of the invention and the embodiment 1 of the present invention disclose the effect of improving glucose intolerance in 'Compound No. 58'. However, since substitutes G and E in 'Compound No. 58' are not specified, it is unclear which compound with the chemical structure generates the concerned effect. Therefore, the examiner can notify the ground for rejection under Article 42(3) of the Patent Act, indicating that confirming the concerned effect by combining the types of substitutes that correspond to the disclosed G and E would ask a person skilled in the art to make too much effort. Along with the notification, the examiner may notify another ground for rejection under Article 42(4)(i) of the Patent Act, indicating that the effect of improving glucose intolerance of 'Compound No. 58' cannot serve as the specific ground to forecast that the compound of a chymase inhibitor with the various structures would have the effect of improving glucose intolerance to the similar level.

(3) SIPO analysis

Firstly, "Chymase inhibitor" is a kind of generalization in general terms or a feature defined by function, which shall be construed as embracing all the means that are capable of performing the function of chymase inhibitor. So the extend of protection as defined by claim 1 is clear. In the same way, the extend of protection as defined by claim 2 is clear.

Secondly, for the claims with extensive scope, SIPO would prefer to search for a reference document which discloses a drug containing chymase inhibitor and presenting the same or different medical use, and deduce that the claims 1 and 2 do not possess novelty.

If there is no reference document which can destroy the novelty of claims, SIPO shall examine whether the claim can be supported by the description. "Chymase inhibitor" is a kind of generalization in general terms, which includes all kinds of compounds with different structures and different medical uses. The description only provides the experimental test data of a specific compound. Considering these facts, the generalization of claim 1 and 2 includes contents speculated by the applicant and the effect thereof is difficult to determine or evaluate beforehand, the generalization shall be regarded as going beyond the scope of the contents disclosed in the description. So the claims are not supported by description.

1.2.4 Condition 4

Technical field is Pharmacy. Main question would be whether the claims are supported by description and lack the clarity or not?

(1) JPO Analysis

In the pharmacy field, claims are defined broadly in many cases. Some types of claims, such as functional claims or Markush type claims, are carefully examined by examiners in the light

of clarity and support requirement of claims.

(2) KIPO Analysis

A. Clarity of Claims

Claims 1 and 2: As reviewed in [Condition 1] to [Condition 3], the scope of claims of the inventions in claims 1 and 2 can be deemed to be clear.

Claim 8: The compound of chymase inhibitor in chemical formula (I) is disclosed in the Markush type and therefore, the scope of claims is clearly interpreted, but when looked in detail, the description is unclear in that the number of carbons starts from 1 (1 to 7 carbons) even though alkynyl disclosed in substituent A requires more than two carbons and the type of substituent corresponding to R3 of COOR3 disclosed as the substituent J of is not disclosed. Therefore, a ground for rejection under Article 42(4)(ii) can be notified based on the concerned matters.

B. Supported by Description

Claims 1 and 2: As reviewed in [Condition 3], a 'chymase inhibitor' disclosed as active ingredient of the invention in claims 1 and 2 is not supported by the detailed description of the invention. Therefore, a ground for rejection under Article 42(4)(i) of the Patent Act can be notified.

Claim 8: The invention claiming improvement in glucose intolerance of chymase inhibitor and treatment of diseases resulting from glucose intolerance can constitute the invention of medical use specifying the chymase inhibitor compound.

Therefore, the detailed description of the invention shall disclose the pharmacologic effect to support the medical use at the time of filing. (Supreme Court, Ruling No. 2004 Hu 2444)

Also, since the pharmacologic activation of a medical use invention varies the measured value of each compound based on different substituents, unless special conditions exist, the pharmacologic effect of a specific substance shall be disclosed as experiment examples containing pharmacologic data, etc. (Patent Court, Ruling No. 2010 Huh 5673)

Paragraphs [0215] and [0227] of the detailed description of the claimed invention merely disclose the chymase inhibition activation of a chymase inhibitor in the claimed invention as the broad scope of IC₅₀ indicating that "In the measurement method (A) of IC₅₀, it would be desirable for IC₅₀ to be less than 1000nM, more appropriately less than 500nM, much more appropriately less than 100nM and most appropriately less than 10nM" and "IC₅₀ of Compound 58 is ranged from more than 1nM to less than 10nM." Worse, as for the improvement in glucose intolerance, substituents G and E are not specified in the compounds of the broad chemical formula (I) and only the improvement in glucose intolerance of compound 58 from which it cannot be figured out which compound of which chemical formula is specifically referred to. Therefore, a ground for rejection under Article 42(3) of the Patent Act can be notified, indicating that confirming all the individual effects by combining the type of substituents corresponding to substituents G and E in 'compound 58' would require a skilled person in the art to exert too much effort. Also, a ground for rejection under Article 42(4)(i) of the Patent Act can be notified, with the intention that there is no specific ground on which 'compound 58' and 'compound in chemical formula (I) with the broad scope containing various structures are expected to show the identical level of improvement in glucose intolerance only based on the improvement effect of glucose intolerance of compound 58.

(3) SIPO analysis

Firstly, "A drug for improving glucose intolerance" can be considered as a kind of product claim defined by feature of use, which can be permissible. "Chymase inhibitor" is a kind of generalization in general terms or a feature defined by function, which shall be construed as

embracing all the means that are capable of performing the function of chymase inhibitor. So the extend of protection as defined by claim 1 is clear. In the same way, the extend of protection as defined by claim 2 is clear.

Secondly, claim 1 and 2 are product claims. The actual definitive effect of the feature of use is determined by whether the feature of use in claim 1 and 2 implies that the claimed product has a certain particular structure and/or composition or not. Generally, SIPO would prefer to search for a reference document which discloses a drug containing chymase inhibitor and presenting the same or different medical use. Because the feature of use does not imply that the claimed product has a certain particular structure and/or composition, it is deduced that the claims 1 and 2 do not possess novelty. For example, reference document 2 (CN1418211A) discloses the drug containing chymase inhibitor. Reference document 1 (WO0222595A1) discloses that chymase inhibitor relates to the use for treating diabetes mellitus. Reference document 1 and 2 can separately destroy the novelty of claim 1 and 2.

If there is no reference document which can destroy the novelty of claims, SIPO shall examine whether the claim can be supported by the description. "Chymase inhibitor" is a kind of generalization in general terms, which includes all kinds of compounds with different structures and different medical uses. The description only provides the experimental test data of a specific compound. Considering these facts, the generalization of claim 1 and 2 includes contents speculated by the applicant and the effect thereof is difficult to determine or evaluate beforehand, the generalization shall be regarded as going beyond the scope of the contents disclosed in the description. So the claims are not supported by description.

1.2.5 Condition 5

As to claim 8 of US2007/0032466A1, whether claim 8 is supported by the description or not?

(1) JPO Analysis

Claim 8 is considered to be supported by the detailed description. The description shows specific examples, and the claimed compound seems not to be too broad.

(2) KIPO Analysis

As reviewed in [condition 4], the claimed invention in claim 8 corresponds to the medical use invention specified to the chymase inhibitor compound in claims 1-7 claiming the improvement in glucose intolerance of chymase inhibitor and treatment of diseases resulting from glucose intolerance.

Therefore, the detailed description of the invention shall disclose the pharmacologic effect to support the medical use at the time of filing. (Supreme Court, Ruling No. 2004 Hu 2444)

Also, since the pharmacologic activation of a medical use invention varies the measured value of each compound based on different substituents, unless special conditions exist, the pharmacologic effect of a specific substance shall be disclosed as experiment examples containing pharmacologic data, etc. (Patent Court, Ruling No. 2010 Huh 5673)

Paragraphs [0215] and [0227] of the detailed description of the claimed invention merely disclose the chymase inhibition activation of a chymase inhibitor in the claimed invention as the broad scope of IC_{50} indicating that "In the measurement method (A) of IC_{50} , it would be desirable for IC_{50} to be less than 1000nM, more appropriately less than 500nM, much more appropriately less than 100nM and most appropriately less than 10nM" and " IC_{50} of Compound 58 is ranged from more than 1nM to less than 10nM." Worse, as for the improvement in glucose intolerance, substituents G and E are not specified in the

compounds of the broad chemical formula (I) and only the improvement in glucose intolerance of compound 58 from which it cannot be figured out which compound of which chemical formula is specifically referred to. Therefore, a ground for rejection under Article 42(3) of the Patent Act can be notified, indicating that confirming all the individual effects by combining the type of substituents corresponding to substituents G and E in 'compound 58' would require a skilled person in the art to exert too much effort. Also, a ground for rejection under Article 42(4)(i) of the Patent Act can be notified, with the intention that there is no specific ground on which 'compound 58' and 'compound in chemical formula (I) with the broad scope containing various structures are expected to show the identical level of improvement in glucose intolerance only based on the improvement effect of glucose intolerance of compound 58.

(3) SIPO analysis

Claim 8 is a product claim defined by feature of use "improving glucose intolerance". The actual definitive effect of the feature of use is determined by whether the feature of use implies that the claimed product has a certain particular structure and/or composition or not. Generally, SIPO would prefer to search a reference document, which discloses the compound represented by formula (I) and maybe has the same or different medical use. Because the feature of use does not imply that the claimed product has a certain particular structure and/or composition, it is deduced that the claim 8 does not possess novelty. For example, reference document 2 (CN1418211A) discloses the compound represented by formula (I), which can destroy the novelty of claim 8.

Secondly, if there is no reference document which can destroy the novelty of claims, SIPO shall examine whether the claim can be supported by the description. The general formula of claim 8 defines chymase inhibitor as the compounds with the same or similar common structure. But the general formula has more variable and more definition, which includes all kinds of compounds with different structures and different medical uses. The description only provides the experimental test data of a specific compound. Considering these facts, the generalization of claim 8 includes contents speculated by the applicant and the effect thereof is difficult to determine or evaluate beforehand, the generalization shall be regarded as going beyond the scope of the contents disclosed in the description. So the claim 8 is not supported by description.

1.2.6 Condition 6

When the examiner concludes that claim X is not supported by the description, does the examiner have to provide solid evidence, such as prior art evidence?

(1) JPO Analysis

Where an examiner determines that the content disclosed in the detailed explanation of the invention can neither be expanded nor generalized to the scope of the claimed invention even in light of the common general knowledge as of the filing, the examiner shall explain the reason why he/she determines so, while showing the grounds for such determination (e.g. the part of the statement of the detailed explanation of the invention and the content of the common general knowledge as of the filing that he/she has taken into account when making the determination).

(2) KIPO Analysis

In interpreting Article 42(2) of the Patent Act, “the detailed description of the invention” refers to the rest of descriptions disclosed in the specification which an applicant submits by attaching the application, except for the title of the invention, brief explanation of drawing(s) and the scope of patent claims.

Whether an invention disclosed in claims is disclosed in the detailed description of the invention shall be determined based on whether the matter corresponding to the invention disclosed in claims is disclosed in the detailed description of the invention from the perspective of a person skilled in the art to which the invention pertains. In such a case, the examiner shall determine the corresponding relation between the scope of patent claims and the detailed description of the invention from the perspective of a person skilled in the art and notify a ground for rejection. Unless where novelty and inventive step are determined, additional evidential documents are not necessarily required.

(3) SIPO analysis

In SIPO, the assessment of whether the claims are supported by the description is generally based on the contents sufficiently disclosed in the description, and combined with the predictable contents through prior art. As to claim 8 in this case, examiners are primarily concerned about the compounds with experimental test data (glucose intolerance experiment) in the description, also combine with prior art mentioned in the description as well as the structure-activity relationship known by person skilled in the art, and preliminarily point out the solutions that are not supported by the description. Prior art can also be mentioned as the evidence when necessary.

1.2.7 Condition 7

If the examiner concludes "lack of support", can the applicant overcome this conclusion by submitting experimental data?

(1) JPO Analysis

Submitted experimental data can be considered by examiners, but the experimental data cannot be added to the original contents of the application. For example, examiners determine the support requirement with the common technical knowledge, but sometimes the considered common technical knowledge can be misjudged. In this case, applicants can give counterevidence by submitting experimental data.

(2) KIPO Analysis

As reviewed in [condition 6], when determining whether the invention is supported by the detailed description of the invention, in interpreting Article 42(2) of the Patent Act, “the detailed description of the invention” refers to the rest of descriptions disclosed in the specification which an applicant submits by attaching the application, except for the title of the invention, brief explanation of drawing(s) and the scope of patent claims.

In other words, whether the invention is supported by the detailed description of the invention shall be determined based on whether the matter corresponding to the invention disclosed in claims is disclosed in the detailed description of the invention from the perspective of a person skilled in the art to which the invention pertains. Therefore, in principle, submission of additional data cannot determine whether the invention is supported with the detailed description of the invention as well as cannot meet the requirement of description of the detailed description of the invention. However, even though the requirement of description of the detailed description of the invention is met, but only when it is deemed that its effect is doubtful, submission of additional experiment data can be allowed as a complementary measure.

(3) SIPO analysis

The requirement of experiment test data in support issue is similar to that in sufficiently disclosed issue. In SIPO, the later submitted experimental data is not allowable to be added to the description. However, in case that the later submitted experimental data is described in the written opinion, an examiner should consider the data during examination. The later submitted experiment data and embodiment can be deemed as evidence to argue that the invention is either inventive or it is fully disclosed, or supported by the specification. The examiner may accept this evidence and grant.

2. Case 2 (JPO selection in 2013)

2.1 Overview of the invention

(1) Title : PROCESS FOR PRODUCING SUBSTANCE

(2) Claims

[Claim 1]

A method for the production of a target substance by a microorganism, comprising the steps of:

cultivation of a microorganism in a culture medium to allow the target substance to be produced and accumulated in said culture medium; and

collection of the target substance from said culture medium,

wherein said target substance is a substance of which biosynthesis requires reduced nicotinamide adenine dinucleotide phosphate,

wherein said microorganism has been modified to increase in an enzyme activity of nicotinamide nucleotide transhydrogenase so that the ability of said microorganism to produce reduced nicotinamide adenine dinucleotide phosphate is increased,

wherein said target substance is an L-amino acid.

[Claim 2]

A method according to claim 1, wherein said microorganism is a microorganism belonging to the genus *Escherichia* or a coryneform bacterium.

(3) Summary of the description

The object of the present invention is to improve the productivity of a target substance using a microorganism, comprising the steps of cultivating the microorganism in a culture medium to allow the target substance to be produced and accumulated in the culture medium, and collecting the target substance from the culture medium.

A variety of reducing reactions proceed in biosyntheses of substances such as L-amino acids in living organisms. In many cases, the coenzyme NADPH is physiologically used as an intravital reducing substance. For example, glutamate dehydrogenase requires NADPH as a coenzyme in an L-glutamic acid biosynthetic pathway. Aspartate semialdehyde dehydrogenase, dihydrodipicolate reductase require NADPH as a coenzyme in an L-lysine biosynthetic pathway.

In other L-amino acid biosynthetic pathways, NADPH plays an important role as a coenzyme. In addition, L-glutamic acid is essential as a donor of amino groups in many L-amino acid

biosynthetic pathways, therefore, NADPH is also required for supply of amino groups in biosyntheses of L-amino acids.

The present inventors have made studies on the basis of the concept described above. As a result of vigorous studies, the present inventors have succeeded in that a DNA fragment containing a transhydrogenase gene is obtained from a bacterium belonging to the genus *Escherichia*, and abilities of microorganisms to produce reduced nicotinamide adenine dinucleotide phosphate are enhanced by using the DNA fragment. The present inventors have further found that the productivity of a target substance is improved in the above-mentioned microorganisms having enhanced abilities to produce reduced nicotinamide adenine dinucleotide phosphate.

The microorganism to be used in the present invention is not specially limited, provided that it belongs to those having been hitherto used for production of substances, such as bacteria belonging to the genus *Escherichia*, coryneform bacteria, bacteria belonging to the genus *Bacillus*, and bacteria belonging to the genus *Serratia*. It is preferably such a microorganism in which a DNA fragment containing a replication origin of a plasmid has been obtained for the microorganism, a transhydrogenase gene functions, and a number of copies of the transhydrogenase gene can be increased. On the other hand, a strain which originally has a high ability to produce a target substance is most preferred as a strain which is applied for improvement of productivity by the present invention. Because, in the strain having high productivity, effect of the improvement of productivity by the present invention is thought to work strongly, since the phenomena of the hypotheses 1 and 2 described above are caused strongly. There are exemplified *Escherichia coli* B-3996 strain and the like when the target substance is L-threonine, *Escherichia coli* AJ12604 (FERM BP-3579) strain and the like when the target substance is L-phenylalanine, *Escherichia coli* AJ12624 (FERM BP-3853) strain and the like when the target substance is L-glutamic acid, and *Brevibacterium lactofermentum* AJ3990 (FERM P-3387, ATCC 31269) and the like when the target substance is L-lysine.

A means for increasing the NADPH productivity of a microorganism is exemplified by a means for increasing the enzyme activity of transhydrogenase in microbial cells.

A means for increasing the enzyme activity of transhydrogenase is exemplified by a means for increasing an expression amount of a transhydrogenase gene in microbial cells. Further, another means for increasing the enzyme activity of transhydrogenase is to modify a transhydrogenase gene and create a transhydrogenase with increased activity.

A means for increasing an expression amount of a transhydrogenase gene in microbial cells is exemplified by a means for increasing a number of copies of a transhydrogenase gene in microbial cells.

Reference for detail description: EP733712 B, US5830716A, JP2817400B,
KR 10-0230878 B, CN 94194707.6(App. No.)

2.2 Examination Results

2.2.1 JPO

(1) Enablement Requirement

-Criteria-

Where an invention of a process is directed to "a process for manufacturing a product," the definition of "the process can be used" means that the product can be manufactured by the process. Further, the said invention of a process for manufacturing a product should be explained clearly in the detailed description of the invention.

Accordingly, for the invention of a process for producing a substance by using a microorganism, a process for producing the said substance shall be described in the detailed description of the invention so that a person skilled in the art can produce the said substance taking into account the overall descriptions of the specification (excluding claims), drawings and common general knowledge as of the filing.

Further, it is necessary to describe how the said process can be used or at least one use of the said substance.

-Analysis Results-

The specification discloses the source of the strain used, plasmid manufacturing process and genetic recombination process of transformant, etc. in detail through embodiments 1 to 4. Then, the present invention satisfies the enablement requirement.

(2) Clarity

-Criteria-

According to, the invention for which a patent is sought shall be clear, therefore, scope of claim shall be described that an invention shall be clearly identified on the basis of statements of each claim. Since there are not special requirements for microorganisms, general requirement of claims should be applied.

-Analysis Results-

Claim 1 discloses the method of producing L-amino acid by using a microorganism.

"Microorganism" is a general term, and sometimes it is difficult to identify what kinds of microorganisms are included in this term. In this invention, the special technical feature seems to be a mechanism of the production process, but the variety of the microorganisms. Then, in this special case, the term "microorganism" maybe permitted.

Claim 2 defines the kind of microorganism so that the claimed invention is clearer than claim 1.

(3) Support by the Detailed Description of the Invention

-Criteria-

There is no special guideline for microorganism. General requirement is applied for microorganism.

The claimed inventions should not exceed the scope stated in the detailed explanation of the invention. To state in a claim an invention that is not stated in the detailed explanation of the invention means to seek a patent protection for an invention which is not disclosed to the public.

-Analysis Results-

Claim 1 discloses a method of producing L-amino acid by cultivating a microorganism with the increased enzyme activity of nicotinamide nucleotide transhydrogenase. The special technical feature of claim 1 is understandable from the detailed description, a mechanism of improved production process. On the technical knowledge of the concerned technical field as of filing, the claims seem to be sufficiently supported by the detailed description.

2.2.2 KIPO

(1) Enablement Requirement

-Criteria-

The specification shall clearly disclose the method of securing and/or using a microorganism. As for an invention of using a novel microorganism, the specification shall describe the manufacturing methods such as the method of separation, refinement, screening, mutation or genetic recombination in detail so that a person skilled in the art can easily produce the concerned microorganism.

-Analysis Results-

Since the microorganism of the starting matter and the genetic sequence, etc. are deposited or disclosed and the specification discloses the source of the strain used, plasmid manufacturing process and genetic recombination process of transformant, etc. in detail through Embodiments 1 to 4, the present invention satisfies the enablement requirement.

(2) Clarity

-Criteria-

-The claim(s) shall define the invention clearly and concisely (Article 42(4)2 of Patent Act) An invention using a microorganism shall clearly disclose the genus, species or strain name based on the extent of disclosure of the prior art.

-Analysis Results-

Claim 1 discloses the method of producing L-amino acid by using a microorganism. However, despite being the invention of using a microorganism, it only specifies L-amino acid as the target substance and fails to disclose the genus, species or strain name and only discloses the microorganism. Therefore, the invention in claim 1 is unclear.

Claim 2 refers to claim 1, but it specifies the microorganism of claim 1 as genus *Escherichia* or coryneform bacterium. As a result, claim 2 becomes clear.

(3) Support by the Detailed Description of the Invention

-Criteria-

It is determined based on whether the matters corresponding to the claimed invention are disclosed in the detailed description of the invention in the perspective of a person skilled in the art.

-Analysis Results-

Claim 1 discloses the method of producing L-amino acid by using a microorganism, but the detailed description of the invention only discloses the method of producing the increased L-amino acid by improving an enzyme activity of nicotinamide nucleotide transhydrogenase in the specific strain, genus Escherichia or coryneform bacterium. Since the content of the detailed description of the invention cannot be extended or generalized to the extent of the claimed invention based on the technical knowledge of the concerned technical field as of filing, the invention in claim 1 cannot be supported by the detailed description of the invention.

Since claim 2 is dependent upon claim 1 and specifies the microorganism as genus Escherichia or coryneform bacterium, the invention in claim 2 is supported by the detailed description of the invention.

2.2.3 SIPO

Neither of claims 1 or 2 fulfills the support requirement.

In the embodiment section, the description provides three E. coli strains AJ12929, AJ12872 and AJ12930, which are transformed with plasmids comprising transhydrogenase coding gene. The description also discloses that L-amino acid production is improved for E. coli B-3996, Brevibacterium lactofermentum AJ3990, and E. coli AJ12604, said strains being transformed with plasmids comprising transhydrogenase coding gene from E. coli. However, Claims 1-2 broadly define the feature as “microorganism” or “Escherichia or Coryneform bacterium”.

As is known in the art, there is a great variety of “microorganism” or “Escherichia or coryneform bacterium”, and different species and strains of “microorganism” or “Escherichia or Coryneform bacterium” are of different characteristics. In this case, embodiments 1-4 in the description only show several strains with the function of “increasing the production of reduced nicotinamide adenine dinucleotide phosphate by increasing the enzyme activity of nicotinamide nucleotide transhydrogenase”. However, as is shown in the background section of the description, “the biological activity of said enzyme is almost unknown”. Although strains with the above function are obtained by transgenic method in this case, it is not that any of the strains of Escherichia or Coryneform bacterium, after being transformed as in this case, will definitely achieve said effect as expected. Furthermore, there are no evidences in the prior art that microorganisms of said species could obtain the function by transgenic method. Hence, with only several specific strains tested and verified in the embodiment section of the description, a person skilled in the art will not foresee that any of the strains of Escherichia or Coryneform bacterium could increase the production of L- amino acid by increasing the enzyme activity of transhydrogenase in the microorganism. Therefore, the generalization of Claims 1-2 includes matters speculated by the inventor, effects of said matters being hardly pre-determined or evaluated. It is considered that said generalization of the claims goes far beyond the scope disclosed by the description.

3. Case 3 (SIPO selection in 2013)

3.1 Overview of the invention

(1) Title : INDOLE-3-CARBOXYLIC ACID AMIDE, ESTER, THIOAMIDE AND THIOL ESTER COMPOUNDS BEARING ARYL OR HETEROARYL GROUPS HAVING SPHINGOSINE-1-PHOSPHATE (S1P) RECEPTOR ANTAGONIST BIOLOGICAL ACTIVITY

(2) Claims

[Claim 1]

Compounds represented by the formula I having sphingosine- 1 -phosphate receptor agonist and or antagonist biological activity:

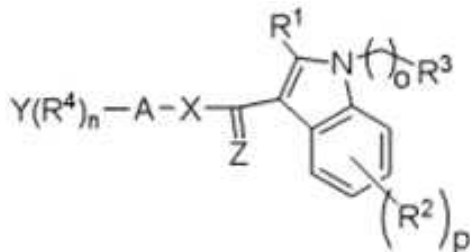

wherein:

X is NR⁵, O, S;

Z is O or S; n is 0 or an integer of from 1 to 4; o is 0 or an integer of from 1 to 3; p is 0 or an integer of from 1 to 4;

A is (C(R⁵)₂)_m, wherein m is 0 or an integer of from 1 to 6;

R⁵ is selected from the group consisting of hydrogen, straight or branched chain alkyl having 1 to 12 carbons, cycloalkyl having 3 to 6 carbons, alkenyl having 2 to 6 carbons and 1 or 2 double bonds, alkynyl having 2 to 6 carbons and 1 or 2 triple bonds, aryl, wherein said aryl is a carbocyclic aryl or heterocyclic aryl group wherein said carbocyclic aryl comprises from 6 to 20 atoms and said heterocyclic aryl comprises from 2 to 20 carbon atoms and from 1 to 5 heteroatoms selected from the group consisting of nitrogen, oxygen and sulfur, halo, C₁-C₁₂ haloalkyl, hydroxyl, C₁-C₁₂ alkoxy, C₁-C₁₂ alkylcarbonyl, formyl, oxycarbonyl, carboxy, C₁-C₁₂ alkyl carboxylate, C₁-C₁₂ alkyl amide, aminocarbonyl, amino, cyano, diazo, nitro, thio, sulfoxyl and sulfonyl groups;

Y is a carbocyclic aryl or heterocyclic aryl group wherein said carbocyclic aryl comprises from 6 to 20 atoms and said heterocyclic aryl comprises from 2 to 20 carbon atoms and from 1 to 5 heteroatoms selected from the group consisting of nitrogen, oxygen and sulfur, and wherein said aryl may be bonded to A at any position;

R¹, R², R³, R⁴ are selected from the group consisting of hydrogen, straight or branched chain alkyl having 1 to 12 carbons, cycloalkyl having 3 to 6 carbons, alkenyl having 2 to 6 carbons and 1 or 2 double bonds, alkynyl having 2 to 6 carbons and 1 or 2 triple bonds, aryl wherein said aryl is a carbocyclic aryl or heterocyclic aryl group wherein said carbocyclic aryl comprises from 6 to 20 atoms and said heterocyclic aryl comprises from 2 to 20 carbon

atoms and from 1 to 5 heteroatoms selected from the group consisting of nitrogen, oxygen and sulfur and may be substituted with C₁-C₁₂ alkyl, C₂-C₆ alkenyl, C₂-C₆ alkynyl, halo, C₁-C₁₂ haloalkyl, hydroxyl, C₁-C₁₂ alkoxy, C₃-C₂₀ arylalkoxy, C₁-C₁₂ alkylcarbonyl, formyl, oxycarbonyl, carboxy, C₁-C₁₂ alkyl carboxylate, C₁-C₁₂ alkyl amide, aminocarbonyl, amino, cyano, diazo, nitro, thio, sulfoxyl, or sulfonyl groups, or a group selected from the group consisting of:

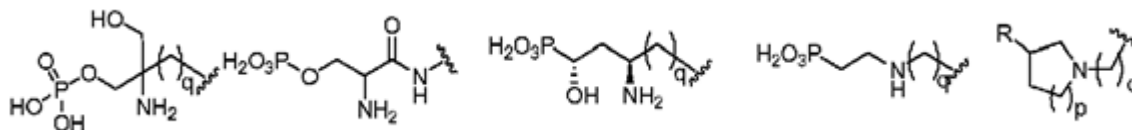

wherein R is CO₂H or PO₃H₂, p is an integer of 1 or 2 and q is 0 or an integer of 1 to 5; provided that, if Y is phenyl, it must be substituted with at least one R⁴ group that is not hydrogen.

[Claim 2]

A pharmaceutical composition which comprises any compound of formula I according to claim 1, for use in treating a disease or condition selected from the group consisting of glaucoma, dry eye, angiogenesis, cardiovascular conditions and diseases, and wound healing.

[Claim3]

The use of a compound of the Formula I according to claim 1 in the manufacture of a medicament for use in the treatment of a disease or condition associated with S1P3 receptor.

(3) Summary of the description

The present invention relates to derivatives and/or analogues of sphingosine and pharmaceutical compositions, including such derivatives and/or analogues, which are useful as drugs for the treatment of fungal infections, allergic diseases, immune disorders, etc.

Recently it has been known that derivatives of sphingo lipids and their related compounds exhibit a variety of biological activities through inhibition or stimulation of the metabolism pathways. These compounds include inhibitors of protein kinase C, inducers of apoptosis, immuno-suppressive compounds, antifungal compounds, and the like. Substances having these biological activities are expected to be useful compounds for various diseases.

Derivatives of sphingosine have been prepared in various patents. For example, see U.S. Patents 4,952,683; 5,110,987; 6,235,912 B1 and 6,239,297 B1.

Also, compounds which are similar to certain sphingosine derivatives, but which are not reported as being ligands for the sphingosine receptors are reported in various patents and published patent applications. See for example, U.S. Patents 5,294,722; 5,102,901; 5,403,851 and 5,580,878. U.S. Patent Application Publication No. U.S. 2003/0125371 A2. While certain of the compounds reported in the above patents are indoles, it does not appear

that indole compounds have been reported as being ligands for sphingosine receptor or having activity as sphingosine agonists or antagonists.

Compounds may be assessed for their ability to activate or block activation of the human S1P3 receptor in T24 cells stably expressing the human S1P3 receptor. In this assay ten thousand cells/well are plated into 384-well poly-D-lysine coated plates one day prior to use. The growth media for the S1P3 receptor expressing cell line is McCoy's 5 A medium supplemented with 10% charcoal-treated fetal bovine serum (FBS), 1% antibiotic-antimycotic and 400 µg/ml geneticin. On the day of the experiment, the cells are washed twice with Hank's Balanced Salt Solution supplemented with 20 mM HEPES (HBSS/Hepes buffer). The cells are then dye loaded with 2 µM Fluo-4 diluted in the HBSS/Hepes buffer with 1.25 mM Probenecid and incubated at 37°C for 40 minutes. Extracellular dye is removed by washing the cell plates four times prior to placing the plates in the FLIPR (Fluorometric Imaging Plate Reader, Molecular Devices). Ligands are diluted in HBSS/Hepes buffer and prepared in 384-well microplates. The positive control, Sphingosine-1 -Phosphate (SIP), is diluted in HBSS/Hepes buffer with 4 mg/ml fatty acid free bovine serum albumin. The FLIPR transfers 12.5 µl from the ligand microplate to the cell plate and takes fluorescent measurements for 75 seconds, taking readings every second, and then for 2.5 minutes, taking readings every 10 seconds. Drugs are tested over the concentration range of 0.61 nM to 10,000 nM. Data for Ca²⁺ responses is obtained in arbitrary fluorescence units and not translated into Ca²⁺ concentrations. IC₅₀ values are determined through a linear regression analysis using the Levenburg Marquardt algorithm.

Reference for detail description: KR 10-2008-102181 A1, WO 2007095561 A,
JP 2009-526863 A, CN 101460458 A

3.2 Examination Results

Three offices compared the examination results under the following several conditions 1 to 6.

3.2.1 Condition 1

The present description includes the test method for assessing the ability of the present compounds to activate or block activation of the human S1P3 receptor in T24 cells stably expressing the human S1P3 receptor, however, no qualitative or quantitative data of the laboratory test results are provided. Under this condition, does the description set forth the invention sufficiently and meet the requirement of sufficient disclosure?

(1) JPO Analysis

[Claim1]

Claim 1 relates to organic compounds per se. In the field of organic compounds, it is only necessary to disclose utility and the method of production and evaluation for the compounds in order to satisfy support and enablement requirements and no qualitative or quantitative data of the laboratory test results are required. When an examiner encounters the condition 1 showing test method and specific utility of organic compounds, he would consider that claim1 meets the support and enablement requirement. Regarding Markush typed claim 1, there could remain another problem whether lots of various compounds included in claim 1 are sufficiently disclosed in the specification. This problem would apply to claim 2, 3.

[Claim2], [Claim3]

The inventions described in claim 2 and 3 are characterized by the medical use of the compounds. Different from organic compounds per se in claim 1, the validity of medical use needs to be evaluated with qualitative or quantitative data of the laboratory test results in the specification. In condition 1 where only the test method and evaluation method are disclosed, an examiner would consider that the disclosure is not sufficient to satisfy the description requirement for medical use of compounds.

(2) KIPO Analysis

[Claim1]

Claim 1 of the present invention ending with the term 'compounds' relates to the compounds represented by the formula I.

According to the examination guideline on organic/inorganic compounds and ceramics (amended in January 2012), the detailed description of a compound invention shall disclose the followings:

- 1) Materials on compounds such as ultimate analysis value, nuclear magnetic resonance (NMR data), melting point and boiling point;
- 2) The manufacturing method detailed enough for a person skilled in the art to easily produce the concerned material (Patent Court, Rulings Nos. 99 Huh 3177 and 2008 Huh 4585);
- 3) The detailed embodiment of technical means; and

4) More than one technically-significant utility on the concerned compound.

The detailed description of the invention and the embodiment of the present invention disclose the detailed embodiment of the compound in the formula I, the manufacturing process of the compound, NMR data and the effectiveness of the compound in treating diseases such as glaucoma, dry eye, angiogenesis, cardiovascular conditions caused by the S1P3 receptor antagonists. Therefore, the invention in claim 1 with the compound of the formula is supported with the detailed description of the invention and is deemed to meet the description requirement of the specification.

[Claim2], [Claim3]

Claims 2 and 3 of the present invention start with 'a pharmaceutical composition' and 'the use of a compound of the Formula I', respectively, for the treatment of a disease. Therefore, the claims constitute a use invention on drugs'.

According to the examination guideline on medicinal drugs and cosmetics (amended in January 2012), a use invention on drugs shall disclose the pharmaceutical effects in the specification at the time of application filing in order to support the medical purpose.

The ruling No. 2004 Hu 2444 of the Supreme Court states that unless special condition exists such as where mechanism of action indicating the pharmaceutical effects described in the specification is clearly proven prior to filing, a use invention of medical drugs where description of the pharmaceutical effect is required shall disclose the experiment examples of pharmacological data or the description of such pharmacological data detailed enough to replace the experiment examples, in order to be deemed that the concerned invention is completed and, at the same time, satisfies the description requirement of the specification. Therefore, even a use invention of medical drugs which fails to disclose its mechanism of action shall not be deemed to be described in detail enough for a skilled person in the art to easily understand the effect of the concerned compound.

Therefore, the examiner may notify the ground for rejection under Articles 42(3)(Enablement Requirement) and 42(4)(i) (Support with Detailed Description of Invention) citing that claims 2 and 3 on the medical use of the compound in the Formula I fail to disclose the qualitative or quantitative experiment data to identify the pharmaceutical effect of the compound in the Formula I.

(3) SIPO analysis

According to Examination Guidelines Part II Chapter 10, Section 3.1, the word "chemical product" includes compound, composition, and chemical product which cannot be clearly described.

Claim 1 seeks to protect the compounds represented by the formula I having sphingosine- 1-phosphate receptor agonist and or antagonist biological activity. The subject matter belongs to the chemical product.

Claim 2 relates to pharmaceutical composition comprising compound of claim 1, the subject matter of which belongs to the chemical product. The compounds contained in the pharmaceutical compositions are novel compounds.

Claim 3 relates to the use of a compound of the Formula I according to claim 1 in the manufacture of a medicament for use in the treatment of a disease or condition associated with S1P3 receptor. The subject matter of claim 3 belongs to the use invention of chemical product.

Examination Guidelines Part II Chapter 10, Section 3.1 reads as follows:

Where the claimed invention is a chemical product itself, the description shall describe the identification, preparation and use of the chemical product.

For a new pharmaceutical compound or pharmaceutical composition, not only its specific medical use or pharmacological action, but also its effective amount and the method of application shall be described. If a person skilled in the art is unable, on the basis of the prior art, to predict that said use or action stated in the invention can be carried out, the qualitative or quantitative data of the laboratory test (including animal test) or clinical test shall be sufficiently provided for the person skilled in the art to be convinced that the technical solution of the invention can solve the technical problem or achieve the technical effect as expected. The description shall describe effective amount, method of application or method of formulation to such an extent that the person skilled in the art can carry it out.

Examination Guidelines Part II Chapter 10, Section 3.3 reads as follows:

As for a use invention of a chemical product, the description shall describe the chemical product to be used, the method for using the product and the effect to be achieved to enable a person skilled in the art to carry it out. If the product to be used is a new chemical product, the statement of the product in the description shall comply with relevant requirements in Section 3.1 of this Chapter. If a person skilled in the art can not predict the use according to the prior art, the description shall sufficiently provide data of experimental tests for a person skilled in the art to be convinced that the product is useful for said use and can solve the technical problem or achieve the technical effect as expected.

Examination Guidelines Part II Chapter 2, Section 2.1.3:

The sufficient disclosure means the person skilled in the art can, in accordance with the contents of the description, carry out the technical solution of the invention, solve the technical problem, and achieve the expected technical effects.

Claims 1-3 of the present application seeks to protect the compounds and uses thereof. Although the description describes the test methods of the ability of the compounds to activate or block activation of the human S1P3 receptor, the description does not provide the test results and experimental data. In addition, the prior art (such as the US patent 4952683, 5110987, 6235912B1, 6239297B1, 5294722, 5102901, 5403851, 5580878, US2003/0125371A1 mentioned in the background of the application) does not disclose or teach that the present compounds of formula I have the ability to activate or block activation of the human S1P3 receptor. That is to say, the present description does not provide the experimental data verifying the biological activity of the compounds, and it can not be predicted by the person skilled in the art that the present compounds having the alleged uses and/or effects. Therefore, the description does not set forth the invention sufficiently and does not meet the requirements of enablement.

Therefore, the examiner may notify the ground for rejection under Articles 26.3(Enablement Requirement) citing that claims 1-3 fail to disclose the qualitative or quantitative experiment data to identify the pharmaceutical effect of the compound in the Formula I.

3.2.2 Condition 2

If the description describes the activity test results as follows: “the IC₅₀ values of the compounds of present invention are between 1nm-100nm”, does the application

meets the requirement of sufficient disclosure?

(1) JPO Analysis

[Claim 1]

Claim 1 meets the description requirement as explained in Condition 1. (Markush would still give some problems in this Condition 2.)

[Claim 2], [Claim 3]

The value of IC_{50} between 1nm-100nm seems to be sufficiently narrow to determine the validity of the experimental data. The disclosed data “the IC_{50} values of the compounds of present invention are between 1nm-100nm” must be the data of specified (identified) examples respectively. If the value of the IC_{50} is recognized as the data of broad conceptual compounds, applicants have to explain the relationship between the compounds and the IC_{50} by comparison of test samples with each value of IC_{50} .

(2) KIPO Analysis

[Claim 1]

Claim 1 of the present invention, starting the term of ‘compounds’, relates to the compound in the Formula I itself and therefore, can be deemed to be supported with the detailed description of the invention, based on the same ground referred to in the above [Condition 1], regardless of the level of description of the pharmaceutical effect and meet the description requirement of the specification.

[Claim 2], [Claim 3]

Claims 2 and 3 of the present invention, starting with the terms of ‘A pharmaceutical composition’ and ‘The use of a compound of the Formula I’ respectively, relate to a use invention of medical drugs. Therefore, as referred to in the [Condition 1] above, the pharmaceutical effect of the concerned invention shall be disclosed in detail as of application filing in order to support its medical use.

However, even if the pharmaceutical effect is disclosed, where the effect is indicated in the form of numerical scope of maximum and minimum values such as “the IC_{50} values of the compounds of present invention are between 1nm-100nm”, the concerned invention shall not be deemed to meet the description requirement of the specification.

It is because the readings of the pharmaceutical activation of the chemical compound vary according to each substituent (Patent Court, Ruling No. 2010 Huh 5673), but since claims 2 and 3 of the present invention relate to the use of the Markush-type compound in the Formula I of the wide scope, the detailed description of the invention is supposed to disclose only the activation of the compounds which can represent the substituent of each Markush-type compound.

Therefore, the examiner can notify the ground for rejection under Article 42(3) (Enablement Requirement) and Article 42(4)(1) (Support with Detailed Description of Invention of the Patent Act), citing that claims 2 and 3 of the present invention relating to the medical use of the compound in the Formula I fail to specify the qualitative or quantitative experiment data in identifying the pharmaceutical effect of the compound in the Formula.

(3) SIPO analysis

Claims 1-3 relates to the chemical compounds, compositions and uses thereof respectively. As referred to in the [Condition 1] above, the pharmaceutical effect of the concerned invention shall be disclosed in detail as of application filing in order to support the alleged

medical uses.

Under this condition, the pharmaceutical effect is disclosed in the form of numerical scope of maximum and minimum values such as “the IC₅₀ values of the compounds of present invention are between 1nM-100nM”. However, the specific test samples, method and results, as well as the corresponding relationship between test result and use/effect are required to be clearly disclosed in the experiments. The description of test results in [condition 2] does not specify the test samples, thus rendering the test results unbelievable. Therefore, the present application does not meet the requirement of enablement.

3.2.3 Condition 3

After the first Office Action, the applicant made amendments to the description by adding the following paragraph [a] before present paragraph [0001].

Paragraph [a]: This application is based on, and claims priority to U.S. Provisional Application No. 60/884,470, filed on Jan. 11, 2007, and US 60/774,102, filed on Feb. 15 2006, which are incorporated herein by reference.

Is this amendment allowable?

(1) JPO Analysis

This amendment itself is allowable, because the matter added by this amendment is just regarded as information of priority. An Examiner does not take into account any information only described in the priority documents, because amendment cannot go beyond the disclosure in the application as of the data of filing.

(2) KIPO Analysis

Amendments in response to the initial notification of the ground for rejection cannot add the new subject matter according to Article 47(2) of the Patent Act. In other words, it is stated that an amendment to the specification or drawings shall be made within the scope of the features disclosed in the specification or drawings initially attached to the patent application. In this context, the features disclosed in the specification or drawings initially attached to the patent application refer to the subject matter explicitly disclosed in the initial specification, etc. or the matters that a person skilled in the art can deem as being identically disclosed in the initial specification, etc. based on the technical knowledge as of filing. Therefore, the matters not directly disclosed, but obviously understood for a person skilled in the art based on the matters described in the initial specification, etc. cannot be deemed as the new addition.

In the concerned case, the priority claim has been made as of international filing and the evidential documents are submitted. Therefore, even though there is no direct description in the specification or drawings of the initially-filed international application as in ‘Paragraph [a]’, but the matters related to ‘Paragraph [a]’ can be deemed to be easily understood by a person skilled in the art based on the common knowledge as of filing, the concerned amendment can be accepted.

(3) SIPO analysis

According to Chinese Patent Law Article 33, an applicant may amend his or its application for a patent, but the amendment to the application for a patent for invention may not go beyond the scope of disclosure contained in the initial description and claims.

Examination Guidelines Part II Chapter 8, Section 5.2.1:

The scope of disclosure contained in the initial description and claims includes the contents described in the initial description and claims, and the contents determined directly and unambiguously according to the contents described in the initial description and claims, and the drawings of the description. The contents described in the initial description and claims submitted by the applicant on the date of filing shall be taken as the basis of examining whether the above-mentioned amendment is in conformity with the provisions of Article 33. The contents of the application documents in foreign language and the priority documents submitted by the applicant to the Patent Office shall not be taken as the basis to judge whether the amendment to the application documents meet the requirements of Article 33, except for the originally filed text in foreign language of an international application entering into the national phase. For the legal effect thereof, see Chapter 2, Section 3.3 of Part III of these Guidelines.

According to the guidelines of SIPO, the basis for amendment includes two parts: 1) contents described in the initial description and claims; 2) the contents determined directly and unambiguously according to the contents described in the initial description and claims, and the drawings of the description. The basic rule for amendment is that no new matters can be introduced to the initial disclosure.

As to the concerned case, paragraph [a] has not been included in the original description directly and explicitly, however the priority claim has been made as of international filing and the evidential documents are submitted. Thus it can be easily accepted by the skilled person that the contents indicated in 'Paragraph [a]' are not new matters. Thus, whether the priority information is introduced into the description or not, the information got by public is the same. Therefore the amendment is allowable. Nevertheless, even the priority information is introduced into the description, the contents of the priority document should not be deemed to be introduced into the description, since the priority documents submitted by the applicant to the Patent Office shall not be taken as the basis to judge whether the amendment to the application documents meet the requirements of Article 33.

3.2.4 Condition 4

The applicant argued that the present invention claims the priority of US 60/774,102 (i.e. US 7,737,173 which has already been granted by USPTO) and US 60/884,470 (i.e. US 20080171772). Both these priority documents have provided the test data of S1P3 IC₅₀ values of the present compounds. That is to say, the test data have been disclosed in the priority documents, verifying that the present invention has been finished before the priority date. Therefore the applicant deems that the present application meets the requirement of sufficient disclosure.

Can this argument be accepted? Considering the argument, does the application meet the requirement of sufficient disclosure?

(1) JPO Analysis

[Claim 1]

This kind of argument cannot be taken into consideration. Whether the claimed invention

satisfies the sufficient disclosure requirement is, in principle, determined only based on the description of the application as of the filing date. The data described only in priority documents cannot be taken into consideration.

However, the claim 1 originally meets the disclosure requirement as explained in Condition 1 and 2.

[Claim 2], [Claim 3]

Same as claim 1, this argument cannot be taken into consideration.

The analysis results are same as Condition 1 or 2.

(2) KIPO Analysis

[Claim 1]

Claim 1 of the present invention, starting with the term 'Compounds', relates to the compound of the Formula I itself. Therefore, it can be deemed that based on the same ground referred to in the above-mentioned [Condition 1], the claim is supported with the detailed description of the invention regardless of the content of the priority document and meets the description requirement of the specification.

[Claim 2], [Claim 3]

The concerned invention is an application claiming priority under the Paris Convention.

According to Article 54 of the Patent Act, the same invention as a patent application filed to a country party under the Treaty has the same filing date in the Republic of Korea as the filing date in the country party under the treaty.

According to the Examination Guideline on Patent and Utility Model, even for the content disclosed in the priority document, where the content of the application claiming priority under the Treaty has changed due to errors in the translation, etc., the lack of description is determined only based on the specification of the application claiming priority under the treaty. Therefore, amendments where the technical features only disclosed in the priority document, but not in the initial specification of the application claiming priority under the Treaty are newly added, or where the invention unworkable based on the matters disclosed in the specification of the application claiming priority under the Treaty is amended to be workable are not accepted.

According to the description of the Examination Guideline above, the description requirement of the detailed description of the invention is determined only based on the specification of the application claiming priority under the treaty, apart from the content disclosed in the priority document.

Therefore, the specification of the application claiming priority does not disclose the experiment data to identify the activation on S1P3 in the compound of the Formula I. Therefore, it cannot be deemed that claims 2 and 3 of the application claiming priority under the Treaty only based on the content disclosed in the priority document meet the disclosure requirement of the detailed description of the invention.

Therefore, the examiner can notify the ground for rejection under Articles 42(3) (Enablement Requirement) and 42(4)(i) (Support with Detailed Description of Invention) of the Patent Act citing that claims 2 and 3 of the present invention claiming the medical use of the compound in the Formula I do not disclose qualitative or quantitative experiment data in identifying the pharmaceutical effect of the compound in the Formula I.

(3) SIPO analysis

Examination Guidelines Part II Chapter 2, Section 2.1:

Article 26.3 provides that the description shall set forth the invention or utility model in a

manner sufficiently clear and complete so as to enable a person skilled in the art to carry out the invention or utility model.

The description shall set forth the invention or utility model in a manner sufficiently clear and complete to such an extent that a person skilled in the art can carry it out. In other words, the description shall comply with the requirement of disclosing the invention or utility model sufficiently. For the definition of the "person skilled in the art", Chapter 4, Section 2.4 of this Part shall apply.

Examination Guidelines Part II Chapter 4, Section 2.4:

The person skilled in the art refers to a fictional "person" who is presumed to be aware of all the common technical knowledge and have access to all the technologies existing before the filing date or the priority date in the technical field to which the invention pertains, and have capacity to apply all the routine experimental means before that date. However, he is not presumed to have creativity. If the technical problem to be solved impels that person to seek technical means in other technical field, he should also be presumed to have access to the relevant prior art, common technical knowledge, and routine experimental means in the other technical field before the filing date or the priority date.

According to our guidelines, whether or not an invention satisfies the requirements of sufficient disclosure shall be evaluated on the basis of the knowledge and capability of the person skilled in the art. The person skilled in the art is presumed to be aware of all the common technical knowledge and have access to all the technologies existing before the filing date or the priority date in the technical field to which the invention pertains, and have capacity to apply all the routine experimental means before that date. Thus in determination of enablement, common technical knowledge and prior art documents shall be taken into consideration.

As to the concerned case, the two patents US20080171772A1 (published on 17 July 2008) and US7737173B2 (published on 15 June 2010) claimed the priority documents of the present application i.e. US60/884470 and US60/774102 as their provisional application respectively. US20080171772A1 and US7737173B2 are not publishing version of the present application, but the family patents of the present application. The priority documents US60/884470 and US60/774102 can not be considered as belonging to the prior art of the application. The two family patents are both published after the filing date and international publication date of the present application, and thus do not belong to the prior art too. Therefore, the test data described in all these documents can not be used to verify the enablement of present application.

3.2.5 Condition 5

If the original description contains the aforesaid paragraph [a] in [Condition 3], shall the test data in the priority be considered by the examination office in determination of sufficient disclosure?

(1) JPO Analysis

[Claim 1]

Whether the claimed satisfies the sufficient disclosure requirement is, in principle, determined only by the description of the application as of the filing date. The substantial

data described only in priority documents cannot be taken into consideration.

[Claim 2], [Claim 3]

Same as claim 1, sufficient disclosure requirement of the claimed invention is determined only based on the description of the application as of the filing date. The data described only in priority documents cannot be taken into consideration.

(2) KIPO Analysis

[Claim 1]

Claim 1 of the present invention, starting with the term 'Compounds', relates to the compound in the Formula I itself and therefore, based on the same ground referred to in [Condition 1] above, the claim can be deemed to be supported with the detailed description of the invention and meet the description requirement of the specification.

[Claim 2], [Claim 3]

Therefore, as referring to in [Condition 4], since the description requirement of the specification of an application claiming priority under the Treaty is determined based on the specification or drawings of the application claiming priority under the treaty, not the content of the priority document, the invention cannot be deemed to meet the disclosure requirement of the specification based on the content disclosed in the priority document.

Even if the initial specification or drawing contains the content of 'paragraph [a]', the description of such content in the specification is merely the reference to the content of priority claim in the application claiming priority under the treaty. Also, the application claiming priority under the Treaty cannot be deemed to disclose the pharmaceutical effect of the compound in the Formula I described only in the priority document in detail enough to meet the description requirement of the specification.

In other words, as for a use invention of chemical compounds as in the claimed invention in claims 2 and 3, the invention can be deemed to be completed only with the description of the detailed pharmaceutical requirement of the chemical compounds in the detailed description of the invention of the application claiming priority under the Treaty and meet the description requirement of the specification, apart from the content disclosed in the priority document. (Supreme Court, Ruling No. 2004 Hu 2444)

(3) SIPO analysis

Examination Guidelines Part II Chapter 2, Section 2.2.3:

Citation of documents shall further comply with the following requirements:

- (1) the documents cited shall be publications, either in paper form, or in electronic form;
- (2) for non-patent documents and foreign patent documents, the publication date shall be earlier than the filing date of the application; for Chinese patent documents, the publication date shall be no later than the publication date of the application; and
- (3) where the cited document is a foreign patent or non-patent document, the source and relevant information of the cited document shall be indicated in the original language as used for its publication. If necessary, Chinese translation thereof shall be provided, and put in parentheses.

If the citation of a document satisfies the above requirements, the description of the application shall be regarded as having set forth the contents of the document. But, it should be noted that, for the convenience of examination and straightforward understanding of the invention by the public, those contents which are indispensable for the description to comply with the requirement of Article 26.3 cannot be described by only reference to other

documents, but shall be substantially described in the description. (See Examination Guidelines Part II Chapter 2, Section 2.2.6)

Examination Guidelines Part III Chapter 1, Section 5.3 “Incorporation by Reference” :

As China makes reservations to the above provisions of the Treaty and its Regulations, when the international applications enters the Chinese national phase, where the original international filing date is retained through incorporating the missing elements or parts by reference from earlier application, the Patent Office shall not admit it.

The contents of the description in combination of prior art shall be taken into consideration when examining sufficient disclosure. The priority documents US60/884470 and US60/774102 is not published and is not considered as the prior art of the application, and these documents do not meet the time requirements of cited documents. In SIPO, if a cited document wants to be considered for patentability, there are two conditions need to be satisfied: 1. applicant should clearly identify the cited document when the application enters into China’s national phase; 2. the application has to take a new application date which is the date entering China’s national phase, but not the priority date. According to the Examination Guidelines, applicants cannot make the “Incorporation by Reference” in the following procedures by amend the filing date for China if they have not make a requirement at the time of going through the formalities for entering the national phase. The priority documents US60/884470 and US60/774102 do not meet the requirement for “Incorporation by Reference”, and they are not considered as belonging to the prior art of the application, and these documents do not meet the time requirements of cited documents. Thus, the test data described in all these documents can not be used to verify the enablement of present application.

3.2.6 Condition 6

If the present application contains the experimental data necessary for sufficient disclosure, while said experimental data are not disclosed by the priority document, is the priority valid or not?

(1) JPO Analysis

When the priority document does not have any experimental data, and the present application only has the experimental data, the priority cannot be allowed. The priority is determined claim by claim. The priority of Claim 1 is not affected such difference in disclosure, because claim 1 does not demand detailed experimental data to meet the description requirement.

(2) KIPO Analysis

The system of priority claim under the Treaty in Article 54 of the Patent Act is the system where if a national of a country party which recognizes under a priority right to a patent application filed by a national of the Republic of Korea claims the priority right to a patent application in the Republic of Korea on the basis of the initial application for the same invention in his/her country or other country parties, the filing date of the initial application in the foreign country shall be deemed to be the filing date in the Republic of Korea for the purposes of Articles 29 and 36 of the Patent Act.

In order for the concerned priority claim to be legitimate, it shall undergo the formalities examination and substantial examination.

The subjects of the formalities examination on the priority claim under the Treaty include the identicalness of applicants, initial filing of the first filing, normality of the first filing, observance of the priority claim period, indication of the purpose of priority claim and submission of evidential documents of priority claim. Where the priority claim is legitimate based on the result of the formalities examination, the priority claim shall be determined to be valid. Where Articles 29 and 36 of the Patent Act are applied in the substantial examination, retroactive filing dates of inventions shall be determined individually. In other words, the invention identical with the invention disclosed in the priority document shall be examined based on the filing date of the first filing when applying Articles 29 and 36 of the Patent Act, whereas the rest of the invention shall be individually determined based on the filing date of the application claiming priority under the Treaty. (Article 54(1) of the Patent Act, 4(F) of the Paris Convention)

The priority claim of the present invention meets the requirements on the formalities examination and the content of the compound in the Formula I disclosed in claims 1 to 3 and its use are disclosed in the priority document. Therefore, the priority claim can be deemed to be legitimate.

(3) SIPO analysis

Examination Guidelines Part II Chapter 3, Section 4.1.2:

An invention or utility model for the same subject matter as referred to in Article 29 means an invention or utility model of which the technical field, technical problem to be solved, technical solution, and prospective effect are the same as those of the first application respectively. It should be noted that the term "same" herein does not mean that the wording or manner of description is exactly the same.

The verification of priority shall comply with the "Definition of Invention-Creation for the Same Subject Matter" in Examination Guidelines Part II Chapter 3, Section 4.1.2. Invention-Creation for the Same Subject Matter means the technical fields, technical problems to be solved; technical solutions and expected effects are the same. That is to say, in determination of same subject matters, "the same expected effects" is one of the factors that should be considered.

Under the condition that the priority document does not contain the necessary experimental data for sufficient disclosure, and the present application provides the data:

- a) if it can not be predicted by the person skilled in the art that the compounds having the alleged uses and/or effects based on the prior art before the priority date, thus the expected effects can not be considered as the same and the priority claim is not valid;
- b) if it can be predicted by the person skilled in the art that the compounds having the alleged uses and/or effects based on the prior art before the priority date, thus the expected effects are considered as the same and the priority claim is valid.

4. Case 4 (KIPO selection in 2014)

4.1 Overview of the invention

(1) Publication Number: WO 2010/118251 A1

(2) Title of the Invention: Spatial User Interface for Audio System

(3) Target Claim

[Claim 1]

A system to generate a user interface, comprising: a spatial model generator operative to receive input data associated with a user interface element, and to generate output data defining a spatial location at which a user will perceive an audio signal corresponding to the user interface element; a spatial audio effects processor operative to receive as an input an audio input and to generate the studio signal as an output, the audio signal representing the processed audio input as perceived by the user at the spatial location; and a user input device operative to select the audio signal or to alter the spatial arrangement of the audio signal that is perceived by the user.

[Claim 7]

A user interface for a system, device, or application, comprising: ~

[Claim 13]

A method for generating a user interface, comprising: ~

[Made claim 15]

A computer program, comprising:

- accessing information regarding a user interface element;
- generating a spatial model for the user interface element based on the accessed information, the spatial model representing a mapping of the user interface element to a position in a user's perceived audio space; and
- associating an audio signal with the position in the user's perceived audio space.

[Made claim 16]

A computer comprising:

- machine readable memory for storing program instructions and data structures;
- one or more processors for executing program instructions stored in said memory;
- the program instructions stored in said memory for:
 - accessing information regarding a user interface element;
 - ...
 - associating an audio signal with the position in the user's perceived audio space.

[Made claim 17]

A computer program stored in a machine readable memory comprising:

- accessing information regarding a user interface element;
- ...
- associating an audio signal with the position in the user's perceived audio space.

[Made claim 18]

A computer program product comprising: (defined by means)

- means A for accessing information regarding a user interface element;
- ...

means B for associating an audio signal with the position in the user's perceived audio space.

[Made claim 19]

A computer program product comprising: (defined by steps)
step of accessing information regarding a user interface element;
...
step of associating an audio signal with the position in the user's perceived audio space.

4.2 Examination Results

① Is a system (in claim 1) clear? An applicant claimed “a system”. The system can be a server in computer engineering field, but it can be also a way of working. In the dictionary, system is defined as “A system is a way of working, organizing, or doing something which follows a fixed plan or set of rules. You can use system to refer to an organization or institution that is organized in this way.” Which category does the system belong to, product or method?

(JPO) The term “system” in a claim is interpreted as a term meaning the category of “an invention of a product”.

(KIPO) KIPO usually accepts a system claim as a product. However, if an applicant fails to define the system as the product, for example in the description the applicant describes the system as a method or software, an examiner points out its clarity.

(SIPO) The subject matter title of the above claim is “a system”. The “system” clearly defines the category of the above claim, a “product”.

JPO	KIPO	SIPO
Clear, Product	Clear, Product	Clear, Product

② Is a user interface (in claim 7) clear that what it claim? For the user interface, the applicant defined it as a set of audio signals. [See [0032]] In KIPO, the patent law defines the patentable statutory subject matter as product or method(process). What's the statutory subject matter of the user interface under the patent law in each country? Which category does the system belong to, product or method? How do you treat the claims for user interface, virtual environment, platform, middleware, server, web application, virtual machine, compiler, node, software, service and so on?

(JPO) Claim 7 does not meet clarity requirement.

The category of the invention according to claim 7 is unclear. An examiner does not determine the category of the invention unclear only because the invention is related to “user interface”. In this case, however, the invention of user interface is specified not only with “a user input device” or “a controller” which can be understood as an element of an invention of a product, but also with “plurality of audio signals” which can be understood as an element of an invention of either a process or a product. Therefore, the category of the invention “user interface” of claim 7 is not clear.

The term “user interface” in general has a variety of meanings such as “an operational feeling” or “an environment for the user to operate a computer”. And in this case, there is

no explicit definition of “user interface” in the description. Therefore, it is not possible for a person skilled in the art to understand the exact meaning of the term “user interface”.

(KIPO) KIPO treats a user interface as an unclear claim. It doesn't meet the requirement of clarity of claim. Under the patent law of Korea, the statutory patentable category is product or method. The user interface is not clear in its category. Therefore, claim 7 doesn't meet the clarity of claim.

(SIPO) The subject matter of claim 7 is "a user interface", which is a kind of media to interact and exchange information between a system and a user. The meaning of “user interface” is very wide. It can be understood as the following: a human-machine interaction process, or a human-machine interaction software, or a graphic user interface, or a product implementing the human-machine interaction. Accordingly, the “user interface” in claim 7 can NOT clearly define the subject matter and the category of the claim (product or method).

JPO	KIPO	SIPO
Unclear	Unclear	Unclear

③ Is a method claim of claim 13 clear? There is no specific subject which performs the step of claim. Is the subject of the method claim essential? Is a computer enough for the subject? Which requirements are necessary for clarity of method claim?

(JPO) Claim 13 meets the clarity requirement.

With regard to the clarity requirement for a method claim related to a computer software invention, it is not necessary that a hardware element is stated in claims, but it is required that steps of the method are clear. In addition, whether or not the subject of the method is clear is an important condition for the method claim to be determined clear.

In this case, the subject of the method according to claim 13 is evidently understood as an information processing apparatus such as a computer, taking into account elements of claims (“accessing information regarding a user interface element”, or “associating an audio signal with the position”), embodiments in description and so on. Therefore, claim 13 is considered to be clear.

(KIPO) KIPO enforces that a hardware subject has to be described in a claim. Even a subject of a method is regarded as a computer; computer has to be written explicitly as a subject of a method in the claim. Therefore, claim 13 doesn't meet the requirement of clarity

(SIPO) Claim 13 is “a method for generating a user interface” and comprises several steps. The claim 13 meets the clarity requirement. The subject of a method claim is not compulsory.

JPO	KIPO	SIPO
Clear	Unclear	Clear

④ Which expressions for claims are allowable? Is claim 15 clear? How do you treat a claim for a computer program, a claim for a computer program product, and the computer-

readable medium including a computer program? Is a hardware subject of the computer program claim essential?

(JPO) Claim 15 does not meet the clarity requirement.

"Computer program", "a program product" and "a computer-readable recording medium including a computer program" can be claimed as an invention of a product.

It is not appropriate that "a program" is "accessing information regarding a user interface element" or, "a program" is "associating an audio signal with the position in the user's perceived audio space", because a program per se does not include these steps but does make a computer etc. to execute these steps.

When an invention is claimed using the terms "a program product", since they use terms of which technical scope is not clear, and thereby making the technical scope of the claimed invention unclear, it violates the Patent Act Article 36 (6) (ii). However, the technical scope of the claimed invention will be clear when the explicit definition is provided for such a term in the description without surpassing the ordinary meaning thereof.

(KIPO) Under the patent law of Korea, the statutory patentable category is product or method. The computer program is not defined as one of product or method. Therefore, claim 15 doesn't meet the requirement of clarity. The computer program must be claimed as "a non-transitory computer readable medium storing a computer program ~" or "a computer program stored in a non-transitory computer readable medium".

(SIPO) The claim 15 seeks to protect computer program, which is NOT a statutory subject matter. If an application claims for a computer program, or a computer program product, or the computer-readable medium including a computer program, normally, as long as it states clearly, the claim is clear. However, it does not necessarily mean the subject matter is patentable, it depends on the nature of the invention. The clarity of the claim and the eligibility of the subject matter are two different issues. If an application only claims for computer programs per se, or computer programs recorded in mediums (such as tapes, discs, optical discs, magnetic optical discs, ROM, PROM, VCD, DVD, or other computer-readable mediums), it falls into one of the unpatentable categories which is the rules and methods for mental activities. If an application claims for computer-readable medium, and the medium is defined by the software recorded on it, then the medium can not be patentable, since the core of the invention is the software which belongs to the unpatentable category of the rules and methods for mental activities. However, if the medium also gets the physical improvement in terms of layer composition, channel spacing and new materials etc, then the medium does not fall into the above-mentioned case. The computer programs application can be drafted as process claim or product claim, i.e., an apparatus for executing the process. If it is drafted as a process claim, the functions of the computer program and the way to perform the functions shall be described in detail by the processing steps. If it is drafted as a product claim, each component and their connection, interaction, as well as its function and how the function is implemented by each component should be specified. As to the claim relating to computer program, a hardware subject is not compulsory.

JPO	KIPO	SIPO
Clear	Unclear	Not a statutory subject matter

⑤ Additional Discussions over Clarity

Made Claims	JPO	KIPO	SIPO
Made Claim 16	Clear	Clear	Clear
Made Claim 17	Unclear	Unclear	Not a statutory subject matter
Made Claim 18	Unclear ¹	Unclear	Not a statutory subject matter
Made Claim 19	Unclear ¹	Unclear	Not a statutory subject matter

¹ However, the meaning of the claimed invention will be clear when the explicit definition is provided for “program product” in the description without surpassing the ordinary meaning thereof.

5. CASE 5 (JPO selection in 2014)

5.1 Overview of the invention

(1) Publication Number: WO 96/14670 A1

(2) Title of the Invention: An Antenna Control System

(3) Target Claim

An antenna system comprising: an antenna, having two or more radiating means and **electromechanical means for moving components of one or more phase shifting element to vary the phase of signals supplied to the respective radiating elements to vary downtilt of the beam of the antenna**; a controller for supplying drive signals to the electromechanical means to adjust the downtilt of the beam of the antenna independent of the other.

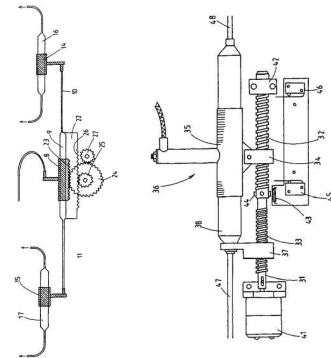

(4) Summary of the description

In order to produce downtilt in the beam produced by an antenna array (for example a panel antenna) it is possible to either mechanically tilt the panel antenna or electrically steer the beam radiated from the panel antenna according to techniques known in the art.

Panel antennas, such as those to which the present application is concerned, are often located on the sides of buildings or similar structures. Mechanical tilting of the antenna away from the side of the building increases the susceptibility of the installation to wind induced vibration and can impact on the visual environment in situations where significant amounts of downtilt are required.

In order to avoid the above difficulties, electrical beam steering can be effected by introducing phase delays into the signal input into radiating elements or groups of radiating elements in an antenna array.

A typical panel antenna will incorporate one or more phase shifters and the present particular embodiment includes three phase shifters. A signal is input to the primary phase shifter which splits the signal into two signals having a desired phase relationship. Each phase shifted signal is then input into a secondary phase shifter whose outputs feeds at least one radiating element. In this manner a progressive phase shift can be achieved across the entire radiating element array, thus providing a means for electrically adjusting the downtilt of the radiated beam. Other phase distributions are possible depending on the application and shape of the radiated beam.

In a panel antenna of the type presently under consideration, it is desirable to adjust the

entire phase shifter array simultaneously so that a desired degree of beam tilt may be set by the adjustment of a single mechanical setting means. The mechanical drive which performs such an adjustment must result in reproducible downtilt angles and be able to be adapted to provide for a number of different phase shifter array configurations.

The present invention provides a mechanical drive system for use in adjusting mechanical phase shifters.

There are two embodiments explaining electromechanical means for use in adjusting mechanical phase shifters in the detailed description. First embodiment uses gear wheel adjusted by a knob, lever, stepper motor or other driven actuator. And, second embodiment uses threaded member driven by a motor.

(Embodiment 1)

Referring to FIG. 1 there is shown the back side of a panel antenna 4 having a first phase shifter 1, a second phase shifter 2, a third phase shifter 3 and a phase shifter drive mechanism 5. Feed line 6 is connected to input 7 of phase shifter 1. A first portion 8 of phase shifter 1 is moveable relative to a second portion 9 of phase shifter 1.

Output signals from phase shifter 1 are supplied via lines 10 and 11 to inputs 12 and 13 of phase shifters 2 and 3 respectively. Feed lines 10 and 11 comprise coaxial push rods which serve the functions both of feeding signals from the outputs of phase shifter 1 to phase shifters 2 and 3 and moving first portions 14 and 15 of phase shifters 2 and 3 relative to second portion 16 and 17 of phase shifters 2 and 3 respectively.

Signals output from phase shifters 2 and 3 are supplied via coaxial lines 18, 19, 20 and 21 to be fed to respective radiating elements (not shown).

In use first portion 8 of phase shifter 1 may be moved relative to second portion 9 of phase shifter 1 to change the relative phase of signals supplied via lines 10 and 11 to phase shifters 2 and 3 respectively. First portions 14 and 15 of phase shifters 2 and 3 may be moved relative to second portions 16 and 17 of phase shifters 2 and 3 to vary the phase of signals supplied by lines 18, 19, 20 and 21 to respective radiating elements.

When phase shifters 1, 2 and 3 are adjusted in the correct respective portions the beam emitted by the antenna can be tilted as required. It will be appreciated that where a less defined beam is required fewer phase shifters may be employed.

To achieve even continuous beam tilting for the embodiment shown in FIG. 1 the first portions 14 and 15 of phase shifters 2 and 3 should move relative to the second portion 16 and 17 of phase shifters 2 and 3 at the same rate. The first portion 8 of phase shifter 1 must however move relative to the second portion 9 of phase shifter 1 at twice this rate. In the arrangement shown second portion 9 of phase shifter 1 is connected to carriage 22. Movement of carriage 22 results in movement of first portions 14 and 15 of phase shifters 2 and 3 via push rods 10 and 11.

Referring now to FIG. 4, operation of the phase shifter drive mechanism will be explained. Second portion 9 of phase shifter 1 is mounted to a carriage 22 which can move left and right. If carriage 22 is moved to the left first portions 14 and 15 of phase shifters 2 and 3 will be moved to the left via push rods 10 and 11. First portion 8 of phase shifter 1 may be moved relative to second portion 9 of phase shifter 1 to vary the phase of signal supplied to phase shifters 2 and 3.

According to this first embodiment a rack 23 is secured to first portion 8 of phase shifter 1. Upon rotation of gear wheel 24 first portion 8 of phase shifter 1 may be moved to the left or the right. A smaller gear wheel 25 is secured to and rotates with gear wheel 24. This gear wheel engages with a rack 26 provided on carriage 22. A further gear wheel 27 is provided which may be driven to rotate gear wheels 24 and 25 simultaneously.

Gear wheel 24 has 90 teeth whereas gear wheel 25 has 30 teeth. It will therefore be appreciated that rotation of gear wheel 24 results in first portion 8 of phase shifter 1 being moved three times as far as carriage 22 (and hence first portions 14 and 15 of phase shifters 2 and 3). However, as carriage 22 is moving in the same direction as the first portion 8 of phase shifter 1 it will be appreciated that the relative movement between first portion 8 and second portion 9 of phase shifter 1 is twice that of the relative movement between the first and second portions of phase shifters 2 and 3. Accordingly, this arrangement results in the relative phase shift produced by phase shifter 1 being twice that produced by phase shifters 2 and 3 (as required to produce even beam tilting in a branched feed arrangement).

(Embodiment 2)

Referring now to FIGS. 5 and 6, a second embodiment will be described. As seen in FIG. 5, the arrangement is substantially the same as that shown in the first embodiment except for the drive mechanism 30 employed, which is shown in FIG. 6.

It will be appreciated that the techniques of both embodiments could be employed in antenna arrays using a larger number of phase shifters. In such applications the relative movement of the first portion of each phase shifter relative to the second portion of each phase shifter would be decreased by a factor of 2 for each successive phase shifter along each branch. The ratios used may be varied if the radiation pattern of the antenna needs to be altered to account for the directivity of the individual radiating elements and the effect of the back panel as the amount of downtilt is varied.

It will be appreciated that a number of mechanical drive arrangements may be used to achieve adjustment of the phase shifters in the desired ratio. It is also to be appreciated that sophisticated control electronics may be employed, although the simplicity of construction of the present invention is seen as an advantage.

[Figures]

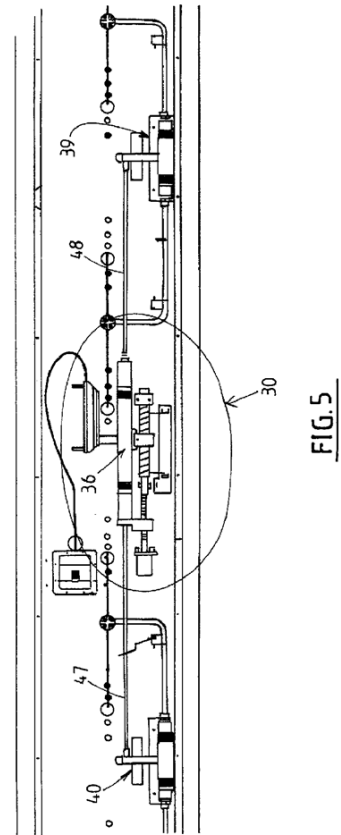
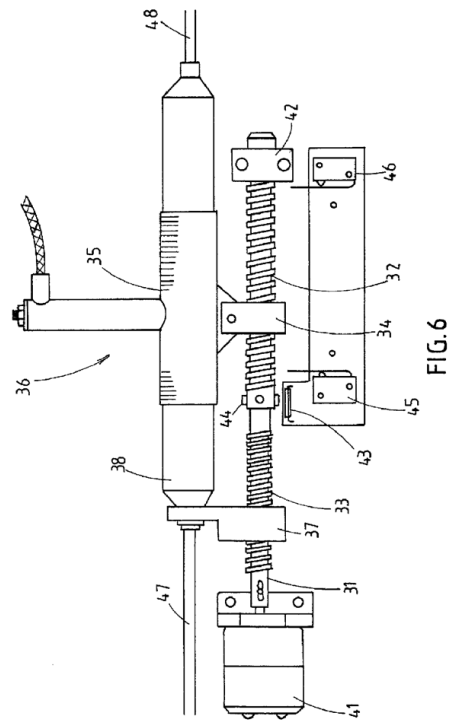
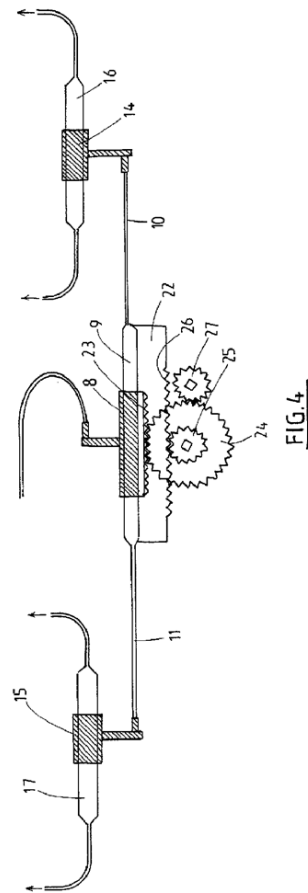
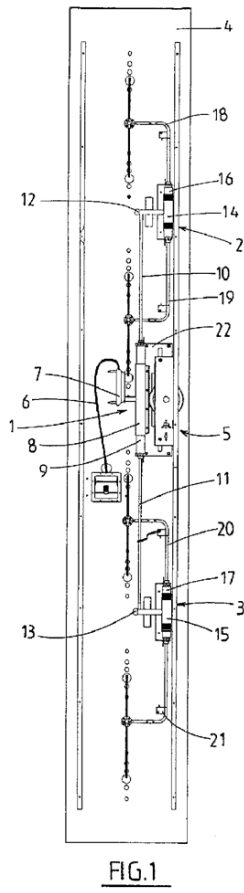

5.2 Examination Results

① Does the invention including the expression as follows “electromechanical means for relatively moving components of one or more phase shifting element to vary the phase of signals supplied to the respective radiating elements to vary downtilt of the beam of the antenna” meet the clarity requirement?

(JPO, KIPO, SIPO) If the person skilled in the art can clearly understand it according to the description as well as the common general knowledge as of the filing, this kind of expression by means of the function is OK.

JPO	KIPO	SIPO
Clear	Clear	Clear

② Does the invention including the expression as follows “electromechanical means for relatively moving components of one or more phase shifting element to vary the phase of signals supplied to the respective radiating elements to vary downtilt of the beam of the antenna” meet the support requirement?

(JPO) It is possible to use expressions defining the invention by stating a function or characteristics, etc., which lead to expansion or generalization of one or more specific examples stated in the description. A claim violates Article 36 (6) (i) by using these forms of expression, when the claimed invention exceeds the scope stated in the description in such a way that a person skilled in the art could recognize that any problem to be solved by the invention would actually be solved.

Claim1 meets the requirement of support because the claimed invention does not correspond to the above case.

(KIPO) The claim 1 meets the support requirement. As above mentioned, KIPO usually examines the breadth of claim in the inventive step stage. Of course, KIPO encourages applicants to write many case study of their invention. However, it's not enforced requirement. Applicants can describe their case study of invention in the application. In this case, applicant only writes a main invention without specific case study. But it's not against the support regulation, so the claim 1 meets the support requirement.

(SIPO) The description does not disclose the shifting which is not in proportion to the relative movement between components of phase shifting elements. However, it can be covered by the claim. The PSA (Person Skilled in the Art) can reasonably doubt that “shifting which is not in proportion” covered by the claim cannot solve the technical problem of “adjusting the entire phase shifter array simultaneously so as to vary the degree of beam tilt”, and cannot achieve the same technical effect. Therefore, the claim is not supported by the description.

JPO	KIPO	SIPO
Supported	Supported	Unsupported

③ Would the invention including the expression meet the requirements for both clarity and support if the electromechanical means was replaced by a specific mechanism like a gear or a motor? (How specific does the explanation need to be, in order to meet both the requirements for clarity and support?)

(JPO) Claim 1 meets the requirements in terms of both clarity and support, as described in condition ① and condition ②.

(KIPO) The claim 1 already meets condition 1 and condition 2. If the specific case or the specific mechanisms of electromechanical means is written, it may make an application better.

(SIPO) If the “electromechanical means” is replaced by a “gear” or a “motor”, the claim is clear, but it does NOT meet the support requirement. The reason is the same as the answer to condition 2. But if the “electromechanical means” is replaced by the specific structures described in the two embodiments in the description, the modified claim can satisfy the support requirement. For this case, an eligible technical solution should solve the technical problem, “adjusting the entire shifter array simultaneously so as to vary the degree of beam tilt”.

JPO	KIPO	SIPO
Clear & Supported	Clear & Supported	Clear & Unsupported

6. CASE 6 (SIPO selection in 2014)

6.1 Overview of the invention

(1) Publication Number: WO 2005/064799 A1

(2) Title of the Invention: Method and Device for Transcoding N-Bit Words into M-Bit Words with M Smaller N

(3) Target Claim

[Claim 1]

Device for transcoding a N bits word into a M bits word, $N > M$, characterizing it comprises: means for breaking down the N bits word into an exponent part and a mantissa part each having a size which varies according to the value of said N bits word, the size of the mantissa part increasing with the value of said N bits word, and means for encoding the exponent part of the N bits word into a variable number of bits A and removing, if need be, least significant bits of the mantissa part in order to obtain a mantissa with a variable number of bits B, with $A+B=M$.

[Claim 2]

Plasma display panel comprising a digamma means (80) for applying a digamma function to video input data (Y[9:0]) and delivering N bits data and a mapping memory (100) for remapping M bits data, with $N > M$ characterized in that it comprises a transcoding device according to claim 1.

☞ Specific mapping table which explains how to transcode the N bits word into the M bits word is provided in description.

1XXXXXXXXXXXXXXXXX	→	111XXXXXXXX
01XXXXXXXXXXXXXXXX	→	110XXXXXXXX
001XXXXXXXXXXXXXXXX	→	101XXXXXXXX
0001XXXXXXXXXXXXXX	→	100XXXXXXXX
00001XXXXXXXXXXXXX	→	011XXXXXXXX
000001XXXXXXXXXXXX	→	010XXXXXXXX
0000001XXXXXXXXXXX	→	0011XXXXXXXX
00000001XXXXXXXXXX	→	0010XXXXXXXX
000000001XXXXXXXXX	→	0001XXXXXXXX
0000000001XXXXXXXX	→	0000XXXXXXXX

[Amended Claim 4]

Device for transcoding a N bits word into a M bits word, $N > M$, characterized it comprises: means for breaking down the N bits word into an exponent part and a mantissa part each having a size which varies according to the value of said N bits word, the size of the mantissa part increasing as the value of said N bits word increases, [the size of the mantissa part increasing with value groups obtained from grouping the value of said N bits word], and means for encoding the exponent part of the N bits word into a variable number of bits A and removing, if need be least significant bits of the mantissa part in order to obtain a mantissa with a variable number of bits B, with $A+B=M$.

6.2 Examination Results

① Is the phrase “if need be” in claim 1 clear? If the phrase “if need be” is replaced with “if necessary”, does it become clear?

(JPO) JPO thinks there is no difference in meaning between the phrase "if need be" and the phrase "if necessary". Therefore, even if the phrase "if need be" is replaced by the phrase "if necessary", the replacement does not lead to any difference in evaluating clarity requirements.

In Japan, a claim does not meet clarity requirements when the scope of the claimed invention is unclear as a result of using an expression like “if need be” along with optionally added items or selected items.

With regard to this case, the requirements for clarity in terms of the phrase “if need be” will not be met because the condition on which the least significant bits of the mantissa part should be removed is unclear and thus the statements in the claim are interpreted in many ways.

(KIPO) “If need be” in claim 1 is not clear. Specific conditions should be suggested. The expressions “if need be” and “if necessary” are regarded as having same meaning in Korean.

(SIPO) In claim 1, the PSA (Person Skilled in the Art) does NOT understand in which conditions the following operation is “needed” to do. Therefore, the protection scope of the claim 1 is NOT clear. Even if the phrase “if need be” is replaced with “if necessary”, the modified claim is NOT clear.

JPO	KIPO	SIPO
Unclear, Unclear	Unclear, Unclear	Unclear, Unclear

② In the application, a specific mapping table which explains how to transcode the Nbits word into the M bits word (see CN1898873A, description, page 4, paragraph 4) is provided.

1XXXXXXXXXXXXXXXXX	→	111XXXXXXXXXX
01XXXXXXXXXXXXXXXX	→	110XXXXXXXXXX
001XXXXXXXXXXXXXXXX	→	101XXXXXXXXXX
0001XXXXXXXXXXXXX	→	100XXXXXXXXXX
00001XXXXXXXXXXXXX	→	011XXXXXXXXXX
000001XXXXXXXXXXXX	→	010XXXXXXXXXX
0000001XXXXXXXXXXX	→	0011XXXXXXXXX
00000001XXXXXXXXXX	→	0010XXXXXXXXX
000000001XXXXXXXXX	→	00011XXXXXX
0000000001XXXXXXx	→	00010XXXXXX
00000000001XXXXXX	→	00001XXXXXX
00000000000XXXXXX	→	00000XXXXXX

In the application, it also provides that (see CN1898873A, description, page 3, paragraph 4): as this transcoding method is used for the output of a degamma function, the input values of this transcoding method represent linear video information. So since the eye is less sensitive

in the bright levels than in the dark levels, the Least Significant Bits of a 16 bits word representing a high value are not important (and may be even not significant). This means that high values do not require as much precision as low values. In the context, does the claim 2 meet the support requirement of support?

(JPO) Claim 2 is not supported by the description.

The problem to be solved in the invention according to claim 2, with consideration of the description, is recognized to suppress an increase in the memory of the circuit for encoding video data in the technical field of the plasma display device. And the description explains, since the high brightness level is difficult to be identified by the human eyes, the means of solving the problem is omitting the lower bits of the codes identifying high brightness level without omitting the lower bits of the codes identifying low brightness level.

The invention according to claim 2 is just identified with “the means for encoding the exponent part of the N bits word into a variable number of bits A and removing, if need be, least significant bits of the mantissa part in order to obtain a mantissa with a variable number of bits B, with $A+B=M$ ”. Then it is not clear whether the invention may omit the lower bits of the codes identifying high brightness level which is difficult to be identified by the human eyes without omitting the lower bits of the codes identifying low brightness level. Moreover, the relationship between the brightness and the number of bits is unclear, and it is also unclear that whether the high brightness means the high number of bits or not.

As explained above, claim 2 does not meet support requirements because the means of solving the problem is not stated in the claim.

(KIPO) A part of claim 2 – mapping memory - is supported by its application. However, the relation of components of claim 2 is not described. If mapping memory is one of claim’s components, it has to be explained how it works with other components in plasma display panel. In this case, some other opinions exist in KIPO. If the digamma means and the transcoding means in the plasma display panel fall under the skilled person’s knowledge, the description of relation is not required. If an examiner decides it as common knowledge, claim 2 meets the support requirement.

(SIPO) The transcoding device of claim 2 is applied in a plasma display panel, and works with a “digamma means” and a “mapping memory”. According to the application, the “digamma means” which works with the “transcoding device”, is not particularly described, thus it is a common “digamma means” in the prior art. It can be inferred that not any kind of transcoding device can be applied in the plasma display panel. According to the description, only a particular mapping table containing 12 ranges of value is disclosed (see CN1898873A, description, page 4, paragraph 4), wherein in each ranges, there is a fixed bit width for the exponent part and the mantissa part and a specific mapping rule to generate the exponent part and the mantissa part. And the mapping from an N bit word to an M bit word is adapted to the feature that the eye is less sensitive in the bright levels than in the darks levels.

As an example, another mapping from an N bit word to an M bit word is presented as following, which is within the protect extent of claim 2. However, f a 16 bit word “65535”

is converted to a 10 bit word "00 0000000", and another 16 bit word "2048" is converted to another 10 bit word "000 000000", the same mapping result is got from mapping two different values. Accordingly, the monotonicity of displaying the result of the digamma function from "0" to "65535" in the plasma display is lost. In this situation, the PSA can NOT determine that whether the image in the display can be recognized by the user and presenting the input data.

convert 16 bit word to 10 bit word

16 bit word	value	10 bit word	
		exponent	mantissa(num of bits)
1xxxxxxxxxxxxxxxxx	32768-65535	00	8
01xxxxxxxxxxxxxxxx	16384-32767	01	8
001xxxxxxxxxxxxxxxx	8192-16383	10	8
0001xxxxxxxxxxxxxxxx	4096-8191	11	8
00001xxxxxxxxxxxxxxxx	2048-4095	000	7
000001xxxxxxxxxxxxxxxx	1024-2047	001	7
0000001xxxxxxxxxxxxxxxx	512-1023	010	7
00000001xxxxxxxxxxxxxxxx	256-511	011	7
000000001xxxxxxxxxxxxxxxx	128-255	100	7
0000000001xxxxxxxxxxxxxxxx	64-127	101	7
00000000001xxxxxxxxxxxxxxxx	32-63	110	7
000000000001xxxxxxxxxxxxxxxx	0-31	111	7

Therefore, the PSA can reasonably doubt that a transcoding device with other rules for mapping value ranges to corresponding mantissa parts and exponent parts could NOT be applicable to the plasma display panel and could NOT achieve the same technical effect. So the PSA can NOT get the technical solution of claim 2 directly or by generalization. The claim 2 can NOT be supported by the description.

JPO	KIPO	SIPO
Unsupported	??	Unsupported

③ Is the expression "the size of the mantissa part increasing as the value of said N bits word increases" in the amended claim 4 clear?

(JPO) This case is recognized as an amendment that "the value of the N-bit word" is replaced by "the value of the group of the values of the N-bit word", and that "remove, if need be, least significant bits of the mantissa part" is replaced by "remove one or more bits in the case the mantissa part is greater than M-A" in claim 1.

For reference to "the value of the group of values of the N bits word", since the term "group" is not described in the description, the claimed invention cannot be supported by the description. Besides, the meaning of "value of the group" is unclear.

In addition, since the phrase "remove one or more bits in the case mantissa part is greater than M-A" does not have the limitation "the least significant" described in claim 1 of the pre-correction, it is unclear which bits are removed.

Due to the same reasons as described in 6. 2 ① and 6. 2 ②, the proposed claim satisfies neither clarity requirements nor support requirements.

Even if "the value of the group of values of the N bits word" is interpreted as the value of 12 "groups" in the case where 12 values are divided from 16-bit values, it is considered not to meet clarity requirements and support requirements.

(KIPO) KIPO mostly accepts this kind of expression. However, the N or the value of N bits is not defined in claim 4. The size of N is key factor in claim 4, so it's better that a upper limit or a lower limit is described concerning the size. Therefore, the expression "the size of the mantissa part increasing as the value of said N bits word increases" is not clear. By the way, some examiners of KIPO have an opinion to accept claim 4. Claim 4 describes the relationship between "the size of the mantissa part" and "the value of said N bits word" explicitly. Therefore, its decision on clarity may depend on the examiner in charge.

(SIPO) The size of the mantissa part: 0 to N, the value range of the N bit word: 0 to 2^N . The meaning of "the size of the mantissa part increasing as the value of said N bits word increases" in claim 4 is that the size of the mantissa part is strictly monotonously increasing as the value of the N bit word increases, which requires the value range of "the size of the mantissa part" is NOT smaller than the value range of "the N bit word". However, it is conflicting with the technical content of claim 4 (the value range of "the size of the mantissa part" is between 0 to N, and the value range of the N bit word is between 0- 2^N). Therefore the scope of claim 4 is NOT clear.

JPO	KIPO	SIPO
Unclear	Unclear	Unclear

III. Summary of results and analysis

1. CASE 1

Conditions	
1	Claims 1 and 2 set forth a drug. "A drug" may be construed as a pharmaceutical compound or a pharmaceutical composition. The question is how to define the subject matter of these claims, a compound or a composition?
2	"Improving glucose intolerance" in claims 1 and 2 can be considered as a feature of use. The question is whether such feature would further restrict the scope of product claim. Is the protection scope regarded as second medical use of known compounds "chymase inhibitor", or the product per se, i.e. a drug containing "chymase inhibitor"?
3	Is the expression "chymase inhibitor" regarded as functional definition? Shall the provision of clarity or provision of sufficient supporting be applied?
4	Technical field is Pharmacy. Main question would be whether the claims are supported by description and lack the clarity or not?
5	As to claim 8 of US2007/0032466A1, whether claim 8 is supported by the description or not?
6	When the examiner concludes that claim X is not supported by the description, does the examiner have to provide solid evidence, such as prior art evidence?
7	If the examiner concludes "lack of support", can the applicant overcome this conclusion by submitting experimental data?

Analysis			
Condition	JPO	KIPO	SIPO
1	Composition	Compound or Composition	Composition
2	Use	Use	Product per se
3	functional	functional	functional
4	-	-	-
5	OK	NG	NG
6	Unnecessary	Unnecessary	Unnecessary
7	Depends on Case	Depends on Case	Depends on Case

Under the condition 1, KIPO only explained the possibility that "A drug" may be construed as a pharmaceutical compound. JPO and SIPO recognized "A drug" as a pharmaceutical composition.

Under the condition 2, SIPO only indicated that a feature of use does not restrict the scope of product claim. JPO and KIPO considered the feature of use for determining the scope of product claim.

Under the condition 3, all three offices mentioned that the expression “chymase inhibitor” is regarded as functional definition.

Under the condition 4, each office explained its concerns about support requirement or clarity requirement in the field of pharmacy.

Under the condition 5, JPO only stated that the claim 8 meets support requirement. KIPO and SIPO explained that the claim 8 is not fulfill the support requirement, and KIPO also explained that the claim 8 includes clarity problem.

Under the condition 6, all three offices confirmed that examiners are not required to show the solid evidence.

Under the condition 7, JPO and KIPO explained that the submission of additional experiment data can be allowed in some cases. In SIPO, the later submitted experimental data is not allowable to be added to the description. However, in case that the later submitted experimental data is described in the written opinion, an examiner should consider the data during examination. The later submitted experiment data and embodiment can be deemed as evidence to argue that the invention is either inventive or it is fully disclosed, or supported by the specification. The examiner may accept this evidence and grant.

2. CASE 2

Evaluation of Support Requirement			
	JPO	KIPO	SIPO
Claim 1	OK	NG	NG
Claim 2	OK	OK	NG

Three offices showed completely separated evaluation on support requirement.

JPO explained that both of claim 1 and claim 2 seem to be sufficiently supported by the detailed description. JPO’s view stands on the understandable special technical feature of the claims, a mechanism of improved production process.

KIPO did not evaluate that claim 1 is supported by the detailed description since the content of the detailed description of the invention cannot be extended or generalized to the extent of the invention in claim 1. KIPO could specify the microorganism as genus *Escherichia* or coryneform bacterium in claim 2, and determined that claim 2 is supported.

SIPO did not determine that either of claim 1 or claim 2 fulfills support requirement, because only three embodiments are described in the description, nevertheless there is a great variety of “microorganism” or “*Escherichia* or coryneform bacterium” written in claims.

(2) Discussion

The three offices discussed in detail, and exchanged opinions.

<JPO comments>

The special technical feature of claim 1 is a producing mechanism. The detailed description of the invention of the present invention only discloses specific strain, genus Escherichia or coryneform bacterium as “microorganism”. In general, as to claimed terms, generalization is carefully evaluated by examiners. In this field, claimed microorganisms are defined by “genus” in many cases, but the special technical feature of the claim 1 also has to be considered. Moreover, on the technical knowledge of the concerned technical field as of filing, genus Escherichia or coryneform bacterium naturally exist in creatures’ bodies. When we consider the all aspects of the claimed invention, the general term “microorganism” should be permitted.

<KIPO comments>

Claim 1 discloses a method of producing L-amino acid by cultivating a microorganism with the increased enzyme activity of nicotinamide nucleotide transhydrogenase. However, the detailed description of the invention of the present invention only discloses a method of producing the L-amino acid with improved productivity by increasing an enzyme activity of nicotinamide nucleotide transhydrogenase in a specific strain, genus Escherichia or coryneform bacterium. Therefore, claim 1 is not supported with the detailed description of the invention.

3. CASE 3

Conditions	
1	The present description includes the test method for assessing the ability of the present compounds to activate or block activation of the human S1P3 receptor in T24 cells stably expressing the human S1P3 receptor, however, no qualitative or quantitative data of the laboratory test results are provided. Under this condition, does the description set forth the invention sufficiently and meet the requirement of sufficient disclosure?
2	If the description describes the activity test results as follows: “the IC ₅₀ values of the compounds of present invention are between 1nm-100nm”, does the application meets the requirement of sufficient disclosure?
3	After the first Office Action, the applicant made amendments to the description by adding the following paragraph [a] before present paragraph [0001]. Paragraph [a]: This application is based on, and claims priority to U.S. Provisional Application No. 60/884,470, filed on Jan. 11, 2007, and US 60/774,102, filed on Feb. 15 2006, which are incorporated herein by reference. Is this amendment allowable?
4	The applicant argued that the present invention claims the priority of US 60/774,102(i.e. US 7,737,173 which has already been granted by USPTO) and US 60/884,470(i.e. US 20080171772). Both these priority documents have provided the test data of S1P3 IC ₅₀ values of the present compounds. That is to say, the test data have been disclosed in the priority documents, verifying that the present invention has been finished before the priority date. Therefore the applicant deems that the present application meets the requirement of sufficient disclosure. Can this argument be accepted? Considering the argument, does the application

	meet the requirement of sufficient disclosure?
5	If the original description contains the aforesaid paragraph [a] in [Condition 3], shall the test data in the priority be considered by the examination office in determination of sufficient disclosure?
6	If the present application contains the experimental data necessary for sufficient disclosure, while said experimental data are not disclosed by the priority document, is the priority valid or not?

Analysis

Condition	JPO	KIPO	SIPO
1	OK	OK	NG
2	OK	OK	NG
3	OK	OK	OK
4	NG	NG	NG
5	NG	NG	NG
6	NG	OK	Depends on Case

Under the condition 1, SIPO only stated that the pharmacological test results are necessary in case the description is explaining that the claimed compound may be applied for medical use. JPO and KIPO stated that the pharmacological test results are not required in case the claimed invention is a compound. All three offices agreed that examiners require the pharmacological test results if the claimed invention is a drag.

Under the condition 2, SIPO explained that the description is not sufficient. KIPO explained that KIPO determines the description is sufficient in case the claimed invention is a compound, but KIPO does not determine the description is sufficient in case the claimed invention is a drag. JPO expressed that the claimed invention may be supported in case either the invention is a compound or a drag.

Under the condition 3, all three offices stated that the amendment is allowable. However, they also explained that the substantial contents in the provisional application cannot be incorporated to the present application.

Under the condition 4, all three offices stated that the test data must be written in the present application. The test data written only in the priority documents cannot be accepted as a content of the present application.

Under the condition 5, all three offices denied the possibility that the present application meets the sufficient disclosure requirement by referring the priority documents listed in the original description of the present application.

Under the condition 6, KIPO explained that the priority claim can be deemed to be legitimate. JPO explained that the priority cannot be allowed. SIPO explained the conditions in which the priority is admitted or not.

4. CASE 4-6

In 2014 JEGPE analyzed the three cases in the electric technical field for evaluating the requirements for claims in terms of clarity and support.

The results show that the evaluations were identical among the three offices. However, some differences were detected in both of the clarity and support requirements. The differences were discussed in 2014 JEGPE meeting.

The fundamental examination guidelines among the three offices are different in part and their application also may be distinguished from each other. With the outcomes from the case study, it is expected that the users in Korea, Japan and China will have a benefit in establishing their strategy to file applications in any of the three countries.