

GUIDELINE

Procedures to file a request to the INAPI (the National Institute of Industrial Property of Chile) for Patent Prosecution Highway Pilot Program

Applicants can request accelerated examination by a prescribed procedure including submission of relevant documents on an application which is filed with the INAPI and satisfies the following requirements under the Patent Prosecution Highway (PPH) pilot program based on the national work products (Part I) or PCT international work products (Part II) from any one of the Global Patent Prosecution Highway (GPPH) participating offices.

When filing a request for the PPH pilot program, an applicant must submit a request form available on the INAPI website¹.

INAPI may, in the event of an excessive number of PPH requests which impede their proper functioning, suspend the implementation of the PPH pilot program. That suspension can may only be activated if the decision to suspend is formally communicated to the other offices three (03)months before the suspension becomes effective.

Part I

PPH using the national work products

1. Requirements

- a) Both the INAPI application on which PPH is requested and the Office of Earlier Examination (OEE) application(s) forming the basis of the PPH request shall have the same earliest date (whether this be a priority date or a filing date).**

For example, the INAPI application (including PCT national phase application) may be either:

(Case I) an application which validly claims priority under the Paris Convention from the OEE application(s) (examples are provided in ANNEX I, Figures A, B, C, H, I and J), or (Case II) an application which provides the basis of a valid priority claim under the Paris Convention for the OEE application(s) (including PCT national phase application(s)) (examples are provided in ANNEX I, Figures D and E), or

(Case III) an application which shares a common priority document with the

¹ <https://ion.inapi.cl/FormulariosPdf/patente/47.Solicitud-de-Participacion.pdf>

OEE application(s) (including PCT national phase application(s)) (examples are provided in ANNEX I, Figures F, G, L, M and N), or

(Case IV) a PCT national phase application where both the INAPI application and the OEE application(s) are derived from a common PCT international application having no priority claim (an example is provided in ANNEX I, Figure K).

b) At least one corresponding application exists in the OEE and has one or more claims that are determined to be patentable/allowable by the OEE.

The corresponding application(s) can be the application which forms the basis of the priority claim, an application which derived from the OEE application which forms the basis of the priority claim (e.g., a divisional application of the OEE application or an application which claims domestic priority to the OEE application (see Figure C in Annex I)), or an OEE national phase application of a PCT application (see Figures G, K, M and N in Annex I). Claims are “determined to be allowable/patentable” when the OEE examiner clearly identified the claims to be allowable/patentable in the latest office action, even if the application is not granted for patent yet. A claim determined as novel, inventive and industrially applicable by the OEE has the meaning of allowable/patentable for the purposes of this pilot program.

The office action includes:

- (a) Decision to Grant a Patent
- (b) Notification of Reasons for Refusal
- (c) Decision of Refusal
- (d) Appeal Decision

For example, if the following routine expression is described in the “Notification of Reason for Refusal” of the OEE, those claims are clearly identified to be patentable/allowable.

“<Claims which has been found no reason for refusal>
At present for invention concerning Claim , no reason for refusal is found.”

c) All claims on file, as originally filed or as amended, for examination under the PPH must sufficiently correspond to one or more of those claims indicated as allowable/patentable in the OEE.

Claims are considered to “sufficiently correspond” where, accounting for differences due to translations and claim format, the claims in the INAPI are of the same or

similar scope as the claims in the OEE, or the claims in the INAPI are narrower in scope than the claims in the OEE. In this regard, a claim that is narrower in scope occurs when a OEE claim is amended to be further limited by an additional feature that is supported in the specification (description and/or claims).

A claim in the INAPI which introduces a new/different category of claims to those claims indicated as allowable in the OEE is not considered to sufficiently correspond. For example, where the OEE claims only contain claims to a process of manufacturing a product, then the claims in the INAPI are not considered to sufficiently correspond if the INAPI claims introduce product claims that are dependent on the corresponding process claims.

Any claims amended or added after the grant of the request for participation in the PPH pilot program must sufficiently correspond to the claims indicated as allowable in the OEE application.

d) The INAPI application must have been published.

The publication in the Gazette must have taken effect, and the time period of 45 days provided in Article 5 of the Chilean Industrial Property Law must have expired.

e) Substantive examination of the INAPI application for which participation in the PPH is requested has not begun. Substantive examination is considered to have begun when the Examiners accept its designation.

2. Documents to be submitted

Documents (a) to (d) below must be submitted by attaching to the request form PPH in filing a request under PPH.

(a) *Copies of all office actions (which are relevant to substantial examination for patentability in the OEE) which were issued for the corresponding application by the OEE and translations of them.*

Either Spanish or English is acceptable as translation language². The applicant does not have to submit a copy of OEE office actions and translations of them when those documents are provided via OEE's dossier access system. If they cannot be obtained by the INAPI examiner via the OEE's dossier access system, the applicant may be notified and requested to provide the necessary documents.

² Machine translations will be admissible, but if it is impossible for the examiner to understand the outline of the translated office action or claims due to insufficient translation, the examiner can request the applicant to resubmit translations.

(b) Copies of all claims determined to be patentable/allowable by the OEE and translations of them.

Either Spanish or English is acceptable as translation language. The applicant does not have to submit a copy of claims indicated to be patentable/allowable in the OEE, and translations thereof when the documents are provided via OEE's dossier access system). If they cannot be obtained by the INAPI examiner via the OEE's dossier access system, the applicant may be notified and requested to provide the necessary documents

c) *Copies of references cited by the OEE examiner*

If the references are patent documents, the applicant doesn't have to submit them because the INAPI usually possesses them. When the INAPI does not possess the patent document, the applicant has to submit the patent document at the examiner's request. Non-patent literature must always be submitted.

The translations of the references are unnecessary.

(d) *Claim correspondence table*

The applicant requesting PPH must submit a claim correspondence table, which indicates how all claims in the INAPI application sufficiently correspond to the patentable/allowable claims in the OEE application.

When claims are just literal translation, the applicant can just write down that "they are the same" in the table. When claims are not just literal translation, it is necessary to explain the sufficient correspondence of each claim.

When the applicant has already submitted above documents (a) to (d) to the INAPI through simultaneous or past procedures, the applicant may incorporate the documents by reference and does not have to attach them.

Part II

PPH using the PCT international work products

1. Requirements

The application which is filed with the INAPI and on which the applicant files a request under the PCT-PPH must satisfy the following requirements:

- (1) The latest work product in the international phase of a PCT application corresponding to the application (“international work product”), namely the Written Opinion of International Search Authority (WO/ISA), the Written Opinion of International Preliminary Examination Authority (WO/IPEA) or the International Preliminary Examination Report (IPER), indicates at least one claim as patentable/allowable (from the aspect of novelty, inventive steps and industrial applicability).**

Note that the ISA and the IPEA which produced the WO/ISA, WO/IPEA and the IPER are limited to the OEE, but, if priority is claimed, the priority claim can be to an application in any Office, see example A' in Annex II (application ZZ can be any national application).

The applicant cannot file a request under PCT-PPH on the basis of an International Search Report (ISR) only.

In case any observation is described in Box VIII of WO/ISA, WO/IPEA or IPER which forms the basis of a PCT-PPH request, the applicant must explain why the claim(s) is/are not subject to the observation irrespective of whether or not an amendment is submitted to correct the observation noted in Box VIII. The application will not be eligible for participating in PCT-PPH pilot program if the applicant does not explain why the claim(s) is/are not subject to the observation. In this regard, however, it does not affect the decision on the eligibility of the application whether the explanation is adequate and/or whether the amendment submitted overcomes the observation noted in Box VIII.

- (2) The relationship between the application and the corresponding international application satisfies one of the following requirements:**
 - (A) The application is a national phase application of the corresponding international application. (See Figures A, A', and A'' in Annex II)**
 - (B) The application is a national application as a basis of the priority claim of the corresponding international application. (See Figure B in Annex II)**

(C) The application is a national phase application of an international application claiming priority from the corresponding international application. (See Figure C in Annex II)

(D) The application is a national application claiming foreign priority from the corresponding international application. (See Figure D in Annex II)

(E) The application is the derivative application (divisional application and application claiming priority etc.) of the application which satisfies one of the above requirements (A) – (D). (See Figures E1 and E2 in Annex II)

(3) All claims on file, as originally filed or as amended, for examination under the PCT-PPH must sufficiently correspond to one or more of those claims indicated as allowable in the latest international work product of the corresponding international application.

Claims are considered to "sufficiently correspond" where, accounting for differences due to translations and claim format, the claims in the INAPI are of the same or similar scope as the claims indicated as allowable in the latest international work product, or the claims in the INAPI are narrower in scope than the claims indicated as allowable in the latest international work product.

In this regard, a claim that is narrower in scope occurs when a claim indicated as allowable in the latest international work product is amended to be further limited by an additional feature that is supported in the specification (description and/or claims).

A claim in the INAPI which introduces a new/different category of claims to those claims indicated as allowable in the latest international work product is not considered to sufficiently correspond. For example, where the claims indicated as allowable in the latest international work product only contain claims to a process of manufacturing a product, then the claims in the INAPI are not considered to sufficiently correspond if the INAPI claims introduce product claims that are dependent on the corresponding process claims.

Any claims amended or added after the grant of the request for participation in the PCT-PPH pilot program must sufficiently correspond to the claims indicated as allowable in the latest international work product.

(4) The INAPI application must have been published.

The publication in the Gazette must have taken effect, and the time period of 45 days provided in Article 5 of the Chilean Industrial Property Law must have expired.

(5) Substantive examination of the INAPI application for which participation in the PPH is requested has not begun. Substantive examination is considered to have begun when the Examiners accept its designation

2. Documents to be submitted

The applicant must submit the following documents attached to the request form in filing a request under PCT-PPH. Some of the documents may not be required to submit in certain cases.

(1) A copy of the latest international work product which indicated the claims to be patentable/allowable and translations of them³

Either Spanish or English is acceptable as translation language. If the copy of the latest international work product is available in Spanish or English via "PATENTSCOPE (registered trademark)"⁴, an applicant need not submit these documents unless otherwise requested by the INAPI (WO/ISA and IPER are usually available as "IPRP Chapter I" and "IPRP Chapter II" respectively in 30 months after the priority date).

(2) A copy of a set of claims which the latest international work product of the corresponding international application indicated to be patentable/allowable and translations of them.

Either Spanish or English is acceptable as translation language. If the copy of the set of claims which are indicated to be patentable/allowable is available in Spanish or English via "PATENTSCOPE (registered trademark)" (e.g. the international Patent Gazette has been published), an applicant need not submit this document unless otherwise requested by the INAPI.

³ Machine translations will be admissible, but if it is impossible for the examiner to understand the outline of the translated office action or claims due to insufficient translation, the examiner can request the applicant to resubmit translations.

⁴ <http://www.wipo.int/pctdb/en/index.jsp>

(3) A copy of references cited in the latest international work product of the international application corresponding to the application.

If the reference is a patent document, the applicant is not required to submit it. In case the INAPI has difficulty in obtaining the document, however, the applicant may be asked to submit it. Non-patent literature must always be submitted. Translations of cited references are unnecessary.

(4) A claims correspondence table which indicates how all claims in the application sufficiently correspond to the claims indicated to be patentable/allowable.

When claims are just literal translation, the applicant can just write down that “they are the same” in the table. When claims are not just literal translation, it is necessary to explain the sufficient correspondence of each claim based on the criteria 1. (3) (Please refer to the Example form below).

When an applicant has already submitted the above mentioned documents (1) - (4) to the INAPI through simultaneous or past procedures, the applicant may incorporate the documents by reference and is thus not required to attach the documents.

3. Procedure for the accelerated examination under the PPH pilot program

The INAPI decides whether the application can be entitled to the status for an accelerated examination under the PPH when it receives a request with the documents stated above. When the INAPI decides that the request is acceptable, the application is assigned a special status for an accelerated examination under the PPH.

In those instances where the request does not meet all the requirements set forth above, the applicant will be notified and the defects in the request will be identified. Before the issue of the notification of not assigning a special status for accelerated examination under the PPH, the applicant will be given opportunity to submit missing documents. Even after the issue of the notification of not assigning a special status for accelerated examination under the PPH, the applicant can request the PPH once again in a renewed request for participation.

If all requirements for accelerated examination under the PPH are met, the INAPI will notify the applicant that the application has been allowed entry on to the PPH.

4. INAPI PPH request form



FPI - 47

SOLICITUD DE PARTICIPACIÓN EN EL PROGRAMA PILOTO DE EXÁMEN ACCELERADO DE PATENTES (PPH)

DATOS BIBLIOGRAFICOS

NÚMERO DE SOLICITUD INAPI	
FECHA DE PRESENTACIÓN DE LA SOLICITUD	

EL SOLICITANTE PIDE PARTICIPAR EN EL PROGRAMA PILOTO DE EXAMEN ACCELERADO DE PATENTES (PPH) CON BASE EN:

OFICINA DE EXAMEN ANTERIOR (OEA)			
NÚMERO DE SOLICITUD DE LA (OEA)	FECHA DE PRESENTACIÓN	FECHA DE PRIORIDAD	
TIPO DE ACCIONES OFICIALES EMITIDAS POR LA OEA	ACCIONES OFICIALES EMITIDAS POR LA OFICINA NACIONAL		
	WO-ISA, WO-IPEA IPER		

DOCUMENTOS REQUERIDOS

ACCIONES OFICIALES EMITIDAS POR LA OEA Y SI SE REQUIERE TRADUCCIONES	SE ADJUNTA COPIA DE LAS ACCIONES OFICIALES EMITIDAS POR LA OEA	
	SE PIDE A LA OFICINA QUE RECUPERE LOS DOCUMENTOS A TRAVÉS DE WIPO CASE	
	SE ADJUNTA TRADUCCIÓN DE LOS DOCUMENTOS	
REIVINDICACIONES PATENTABLES/ ADMISIBLES PARA LA OEA/TRADUCCIÓN	SE ADJUNTA COPIA DE TODAS LAS REIVINDICACIONES QUE SE HAN DETERMINADO QUE SON PATENTABLES	
	SE ADJUNTA TRADUCCIÓN DE LOS DOCUMENTOS	
DOCUMENTOS CITADOS EN LAS ACCIONES OFICIALES EMITIDAS POR LA OEA	SE ADJUNTA COPIA DE TODOS LOS DOCUMENTOS CITADOS EN LAS ACCIONES OFICIALES EMITIDAS POR LA OEA (EXCEPTO LOS DOCUMENTOS DE PATENTES)	
	NO SE CITAN REFERENCIAS	

DOCUMENTOS PRESENTADOS PREVIAMENTE	FECHA

CORRESPONDENCIA DE REIVINDICACIONES	TODAS LAS REIVINDICACIONES DE LA SOLICITUD CHILENA SE CORRESPONDEN SUFICIENTEMENTE CON LAS REIVINDICACIONES CONSIDERADAS PATENTABLES/ADMISIBLES POR LA OEA	
	EL SOLICITANTE MODIFICA EL PLIEGO DE ACUERDO A UNA O MAS DE LAS REIVINDICACIONES CONSIDERADAS COMO PATENTABLES/ADMISIBLES POR LA OEA	

LA CORRESPONDENCIA DE LAS REIVINDICACIONES SE EXPLICA EN LA SIGUIENTE TABLA

REIVINDICACIONES DE LA SOLICITUD	REIVINDICACION CORRESPONDIENTE DE LA OEA	EXPLICACIÓN RELATIVA A LA CORRESPONDENCIA

CORRESPONDENCIA DE LA MEMORIA DESCRIPTIVA	EL SOLICITANTE HA REVISADO LA SOLICITUD Y LA MEMORIA DESCRIPTIVA PRESENTADA Y DECLARA QUE ESTA DE ACUERDO A LOS REQUISITOS Y PRACTICAS CHILENAS	
	EL SOLICITANTE HA MODIFICADO LA MEMORIA DESCRIPTIVA PARA CUMPLIR CON LOS REQUISITOS Y PRACTICAS CHILENAS	

NOMBRE DEL/DE LOS SOLICITANTES O REPRESENTANTES	FECHA

Firma Solicitante o Representante

www.inapi.cl

A A case meeting requirement (a) (I)
- Paris Route-

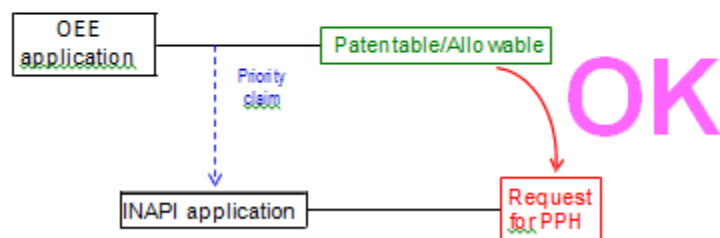

B A case meeting requirement (a) (I)
-PCT route -

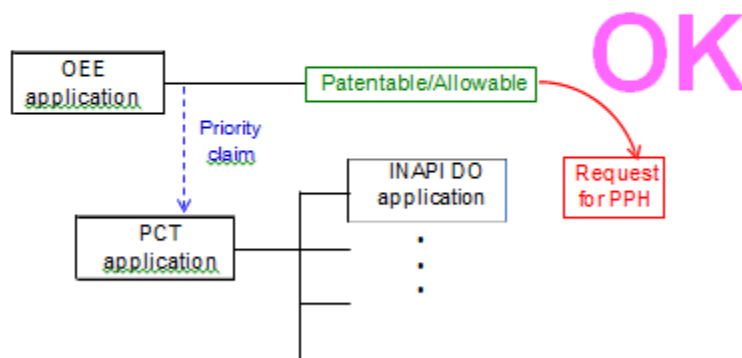

C A case meeting requirement (a) (I)
- PCT route, Domestic priority

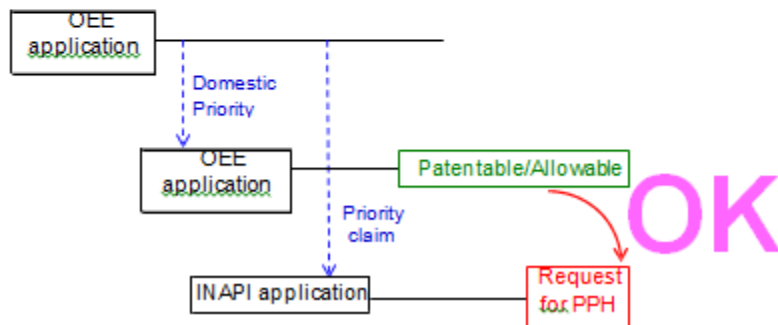

D A case not meeting requirement (a) (II)
- Paris route-

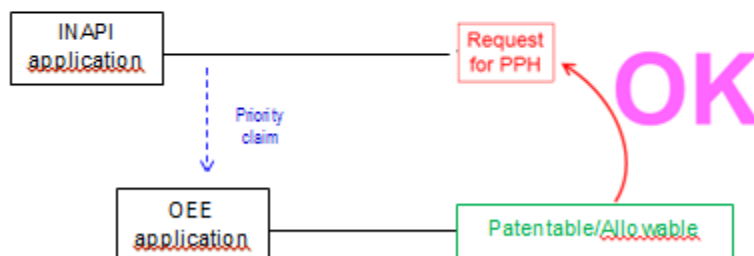

E A case meeting requirement (a) (II)
- PCT route-

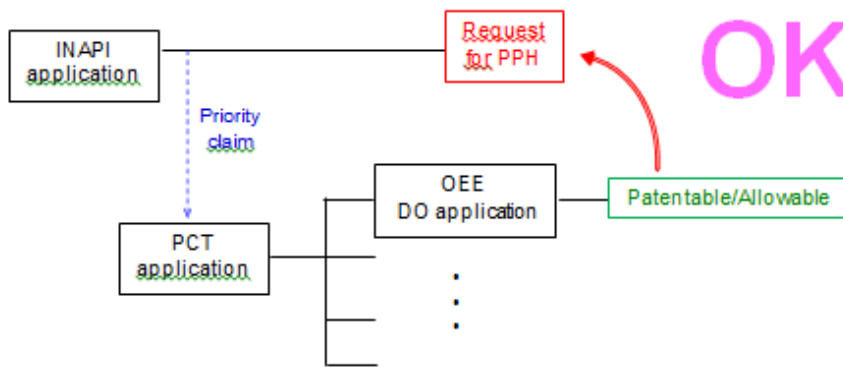

F A case meeting requirement (a)(III)
- Paris route, but the first application is from the third country -

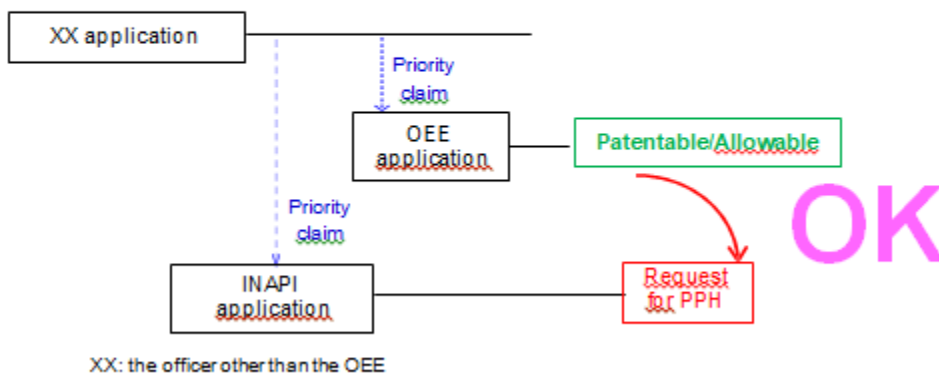

G

A case meeting requirement (a) (III)

- Paris route, but the first applications is from the third country-

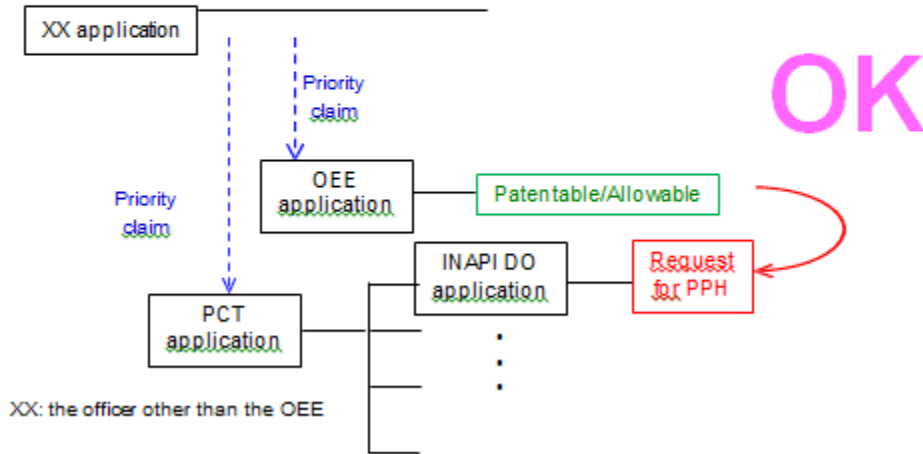

H

A case meeting requirement (a)(I)

- Paris route & Complex priority -

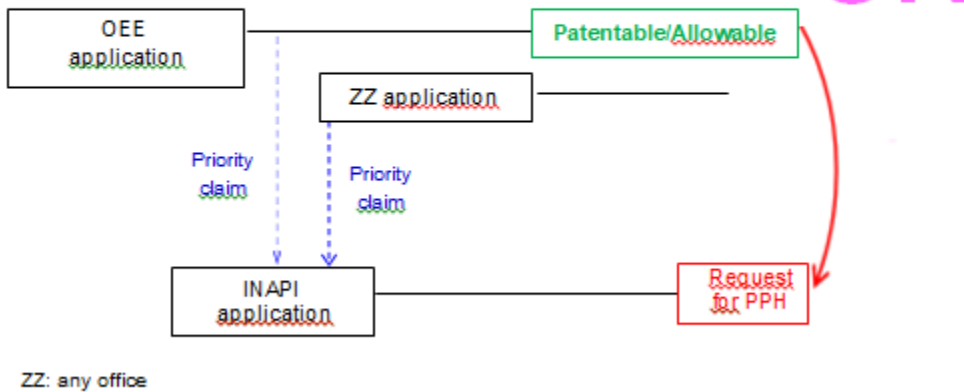

I A case meeting requirement (a) (I)
 - Paris route & divisional application -

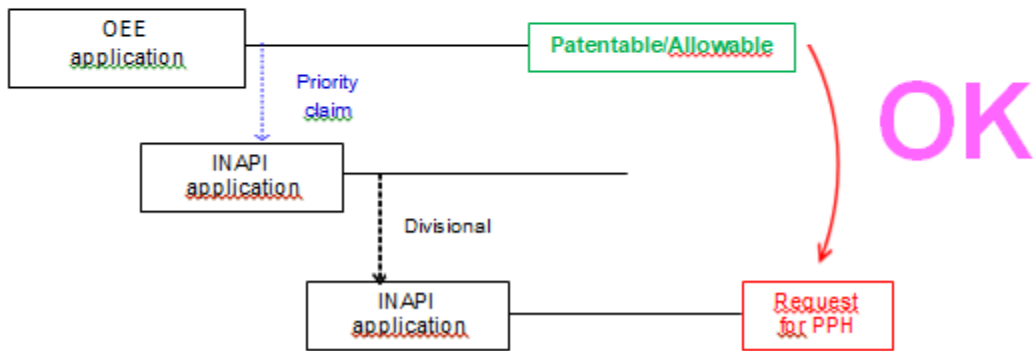

J A case meeting requirement (a) (I)
 - PCT route -

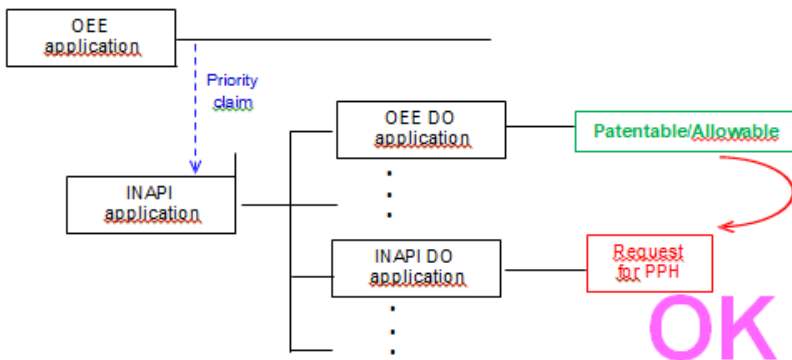

K

A case meeting requirement (a) (IV)

- Direct PCT route -

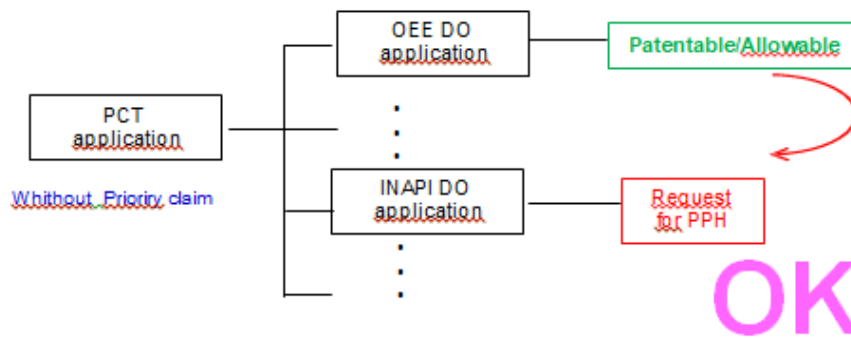

L

A case meeting requirement (a) (III)

- Direct PCT & Paris route-

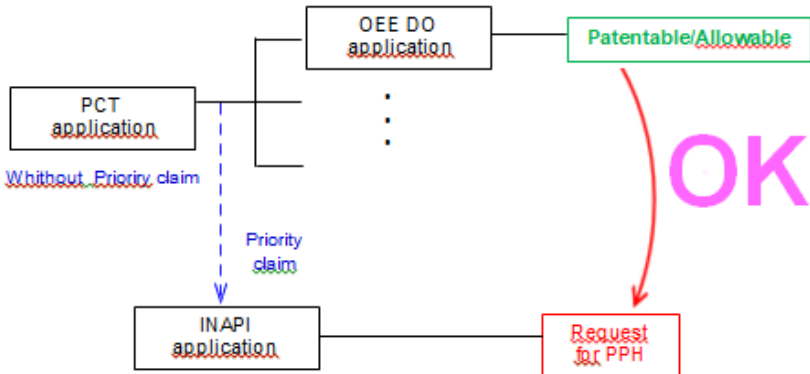

M

A case meeting requirement (a) (III)

- Direct PCT & PCT route-

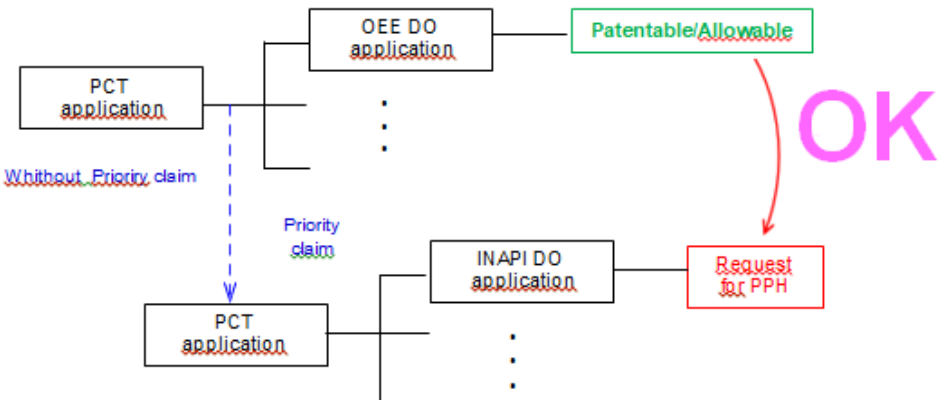

N

A case meeting requirement (a) (III)

- Direct PCT & PCT route-

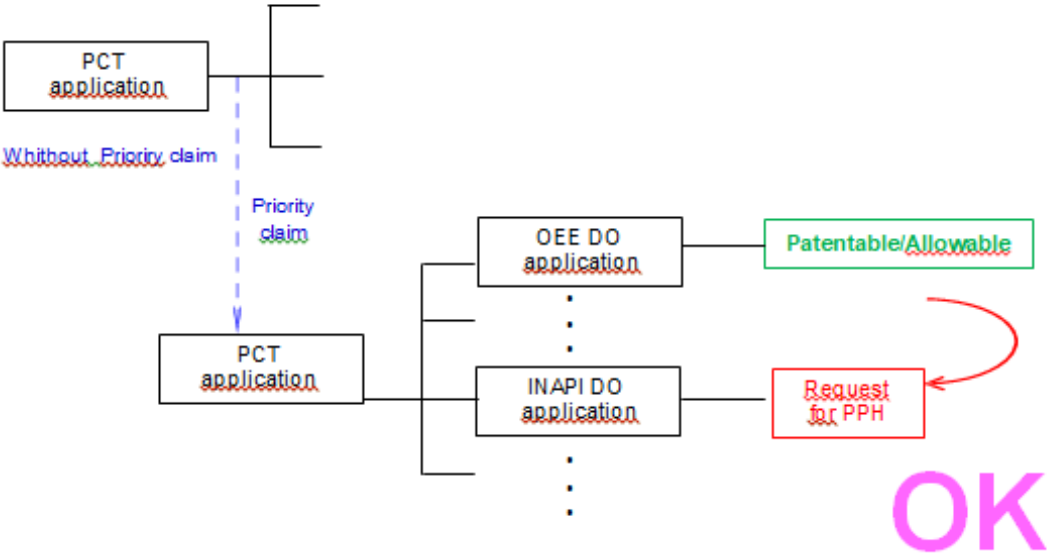

○ A case not meeting requirement (d)
- Examination has begun before a request for PPH-

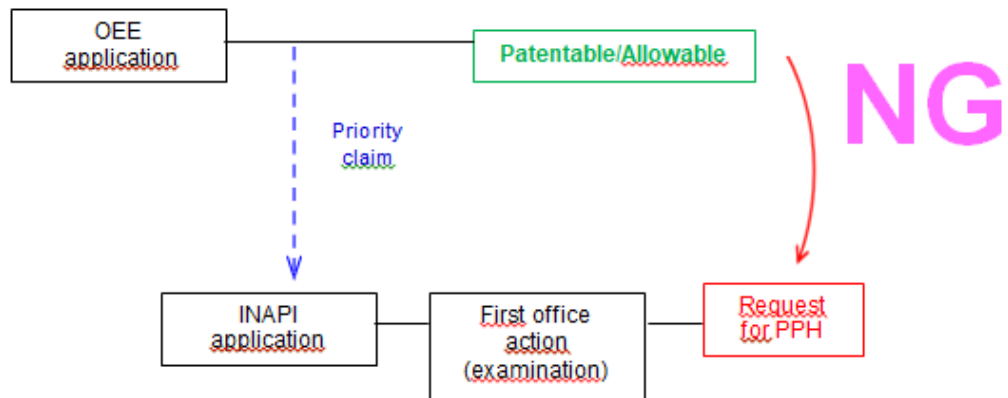

ANNEX II

(A) The application is a national phase application of the corresponding international application.

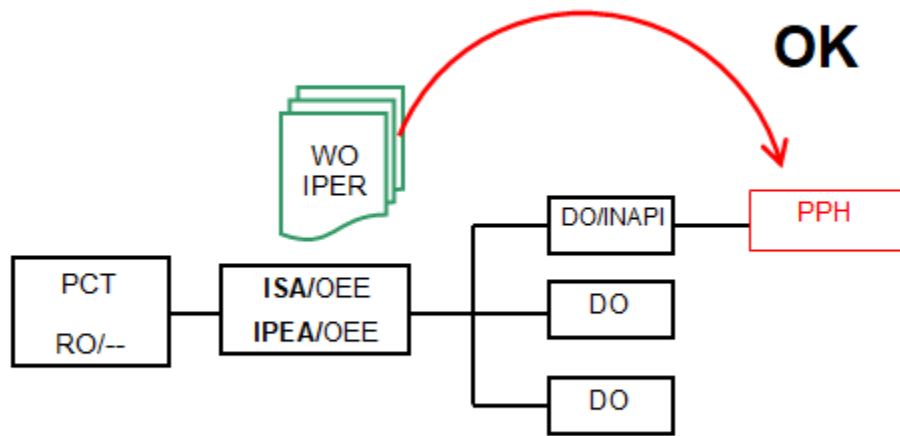

- (A') The application is a national phase application of the corresponding international application.
 (The corresponding international application claims priority from a national application.)

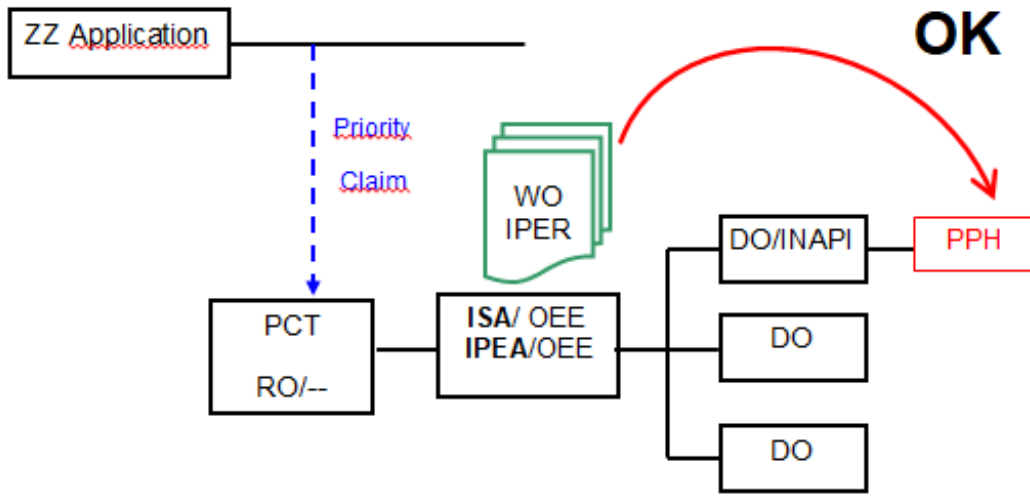

ZZ=any office

(A'') The application is a national phase application of the corresponding international application.
 (The corresponding international application claims priority from an international application.)

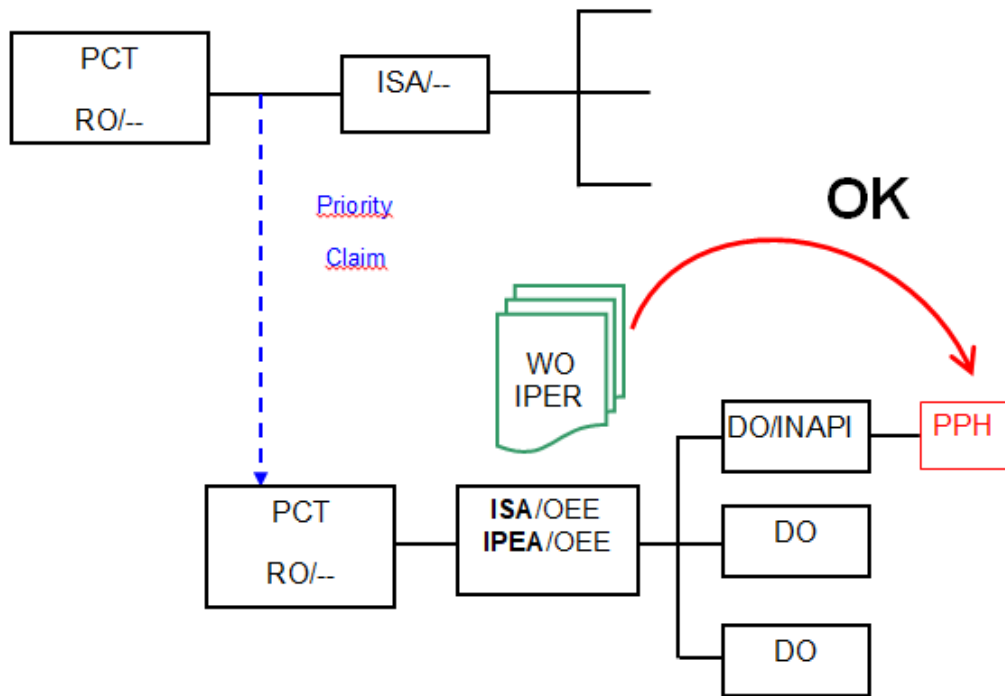

(B) The application is a national application as a basis of the priority claim of the corresponding international application.

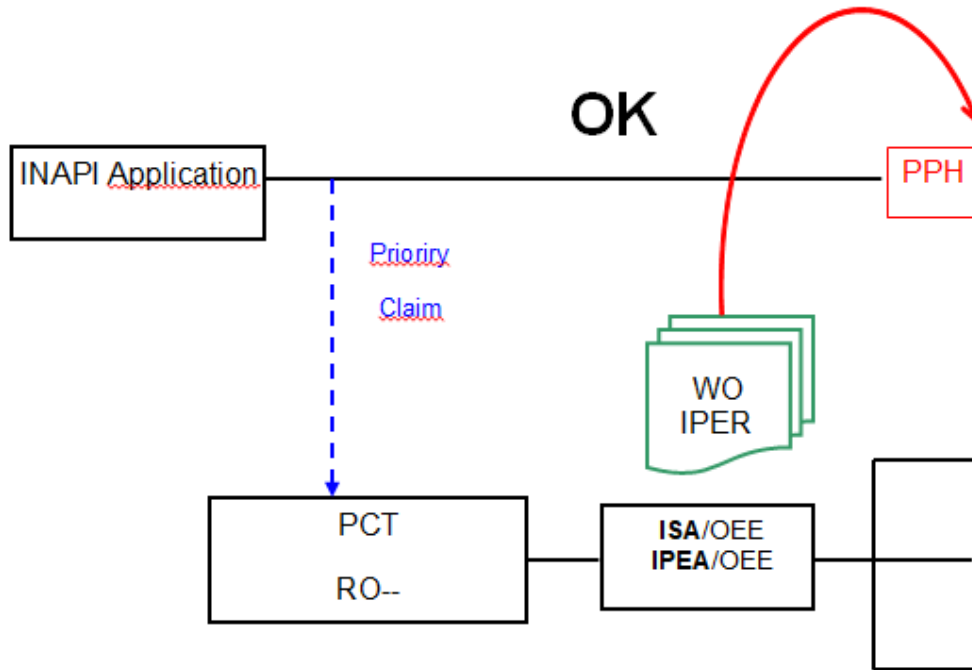

(C) The application is a national phase application of an international application claiming priority from the corresponding international application.

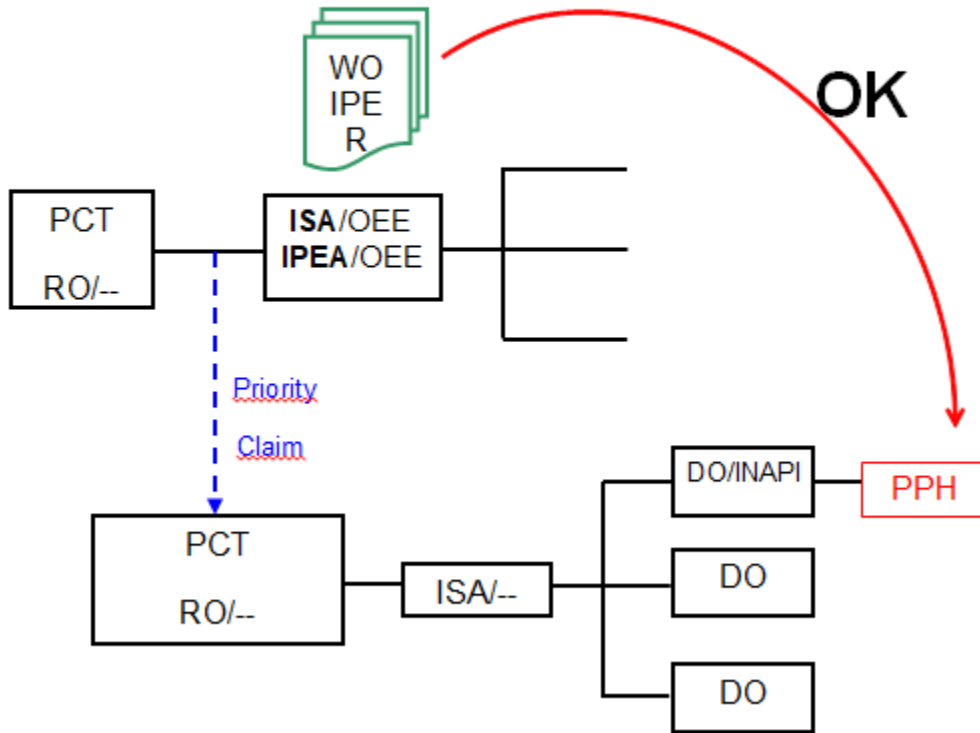

(D) The application is a national application claiming foreign/domestic priority from the corresponding international application.

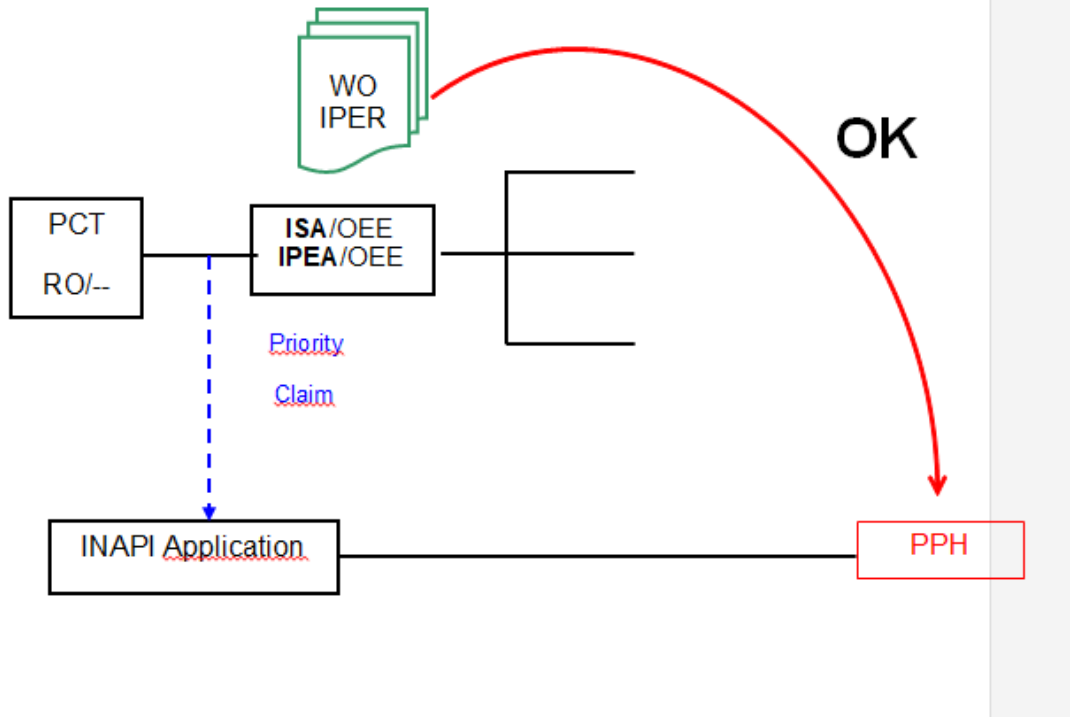

(E1) The application is a divisional application of an application which satisfies the requirement (A).

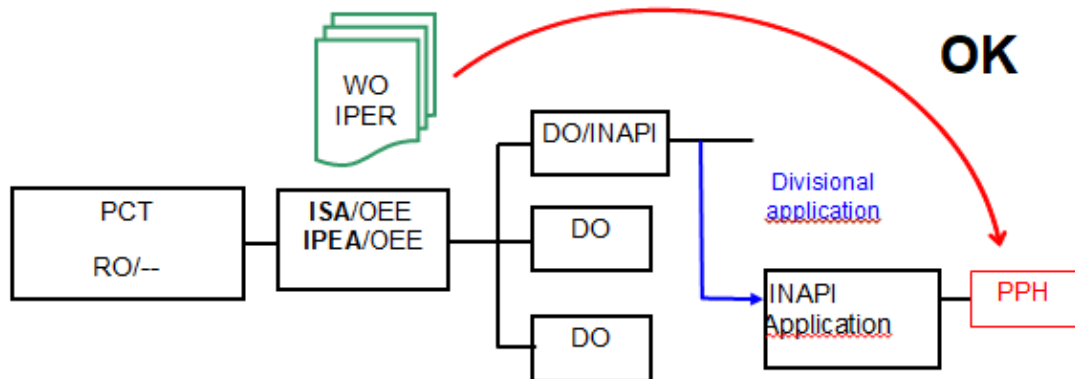

(E2) The application is an application claiming domestic priority from an application which satisfies the requirement (B).

