

Procedures to File a Request to the China National Intellectual Property Administration (CNIPA) for Participation in the IP5 Patent Prosecution Highway (IP5 PPH) Pilot Programme

The world's five Intellectual Property Offices (IP5) - the European Patent Office (EPO), the Japan Patent Office (JPO), the Korean Intellectual Property Office (KIPO), the China National Intellectual Property Administration (CNIPA) and the United States Patent and Trademark Office (USPTO) - agreed in September 2013 to launch a comprehensive IP5 Patent Prosecution Highway (PPH) pilot programme (IP5 PPH) to improve the accelerated treatment of patent applications before the offices.

The pilot period of this IP5 PPH pilot programme commenced on January 6, 2014, and ending on January 5, 2026.

The pilot period may be extended if necessary for the CNIPA and other IP5 offices to adequately assess the feasibility of this PPH programme.

The CNIPA may also terminate this PPH pilot programme early if the volume of participation exceeds manageable level, or for any other reason. Ex Ante notice will be published if this PPH pilot programme is terminated before January 5, 2026.

The current PPH arrangements in place between the CNIPA and JPO, KIPO, and USPTO continue to be applicable as regards the requirements for participating in the PPH pilot programme before the CNIPA.

Part I

PPH using the national/regional work products from the EPO, JPO, KIPO or USPTO

Applicants can request accelerated examination by a prescribed procedure including submission of relevant documents on an application which is filed with the CNIPA and satisfies the following requirements under the IP5 PPH pilot programme based on an EPO, JPO, KIPO or USPTO application.

When filing a request for the PPH pilot programme, an applicant must submit a request form "*Request for Participation in the Patent Prosecution Highway Pilot Programme*" to the CNIPA.

1. Requirements

In order to be eligible to participate in the IP5 PPH pilot programme at the CNIPA, the following requirements must be met:

- (a) **The CNIPA application for which participation in the IP5 PPH pilot programme is requested must have the same earliest date whether this be the priority or filing date of a corresponding national/regional application(s) filed with another IP5 Office.**
The CNIPA application (including PCT national phase application) is either:
- (i) **an application which validly claims priority under the Paris Convention to the corresponding application(s) filed with another IP5 Office (examples are provided in ANNEX I, Figures A, B, C and D), or**
 - (ii) **an application which is the basis of a valid priority claim under the Paris Convention for the corresponding application(s) filed with another IP5 Office (including PCT national phase application(s)) (examples are provided in ANNEX I, Figures E, F and G), or**
 - (iii) **an application which shares a common priority document with the corresponding application(s) filed with another IP5 Office (including PCT national phase application(s)) (examples are provided in ANNEX I, Figures H, I, J, K and L), or**
 - (iv) **a PCT national phase application where both the CNIPA application and the corresponding application(s) filed with another IP5 Office are derived from a common PCT international application having no priority claim (examples are provided in ANNEX I, Figure M).**

- (b) **At least one corresponding application exists in another IP5 office and the corresponding application(s) has/have at least one claim indicated by that IP5 office in its capacity as a national/regional office to be allowable/patentable.**

For the EPO application(s), claims are determined to “be allowable/patentable” i) when a communication regarding the intention to grant a European patent was issued on the claims (The heading of the communication is “*Communication under Rule 71(3) EPC*”); or ii) when a Communication from the Examining Division including its Annex was issued by the EPO examiner explicitly stating the claims to be “allowable/patentable”. If the EPO communication including its annex did not explicitly state that a particular claim is “allowable/patentable”, the applicant must include an explanation accompanying the request for participation in the PPH pilot program that no rejection has been made in the EPO communication regarding that claim, and therefore, the claim is deemed allowable by the EPO. The applicant must also submit an explanation on how the claim implicitly identified to be allowable/patentable mentioned above is delimited over the prior art cited by the EPO examiner.

For the JPO application(s), claims are determined to “be allowable/patentable” when the JPO examiner explicitly identified the claims to be allowable/patentable in the latest office action, even if the application is not granted for patent yet.

The office action includes:

- (i) *Decision to Grant a Patent*
- (ii) *Notification of Reason for Refusal*
- (iii) *Decision of Refusal*
- (iv) *Appeal Decision*

For example, if the following routine expression is described in the “*Notification of Reason for Refusal*” of the JPO, those claims are explicitly identified to be allowable/patentable.

“<Claims which has been found no reason for refusal>

At present for invention concerning Claim __, no reason for refusal is found.”

For the KIPO application(s), in most examination practices of the KIPO, claims in an application are categorized as either “PATENTABLE” or “HAVING REASONS FOR REFUSAL”, and indicated in the office action. Claims are determined to “be allowable/patentable” when the KIPO examiner clearly identified the claims to be “PATENTABLE” in the latest office action, even if the application is not granted for patent yet.

Claims are also “determined to be allowable/patentable” in the following circumstances: If the KIPO office action did not explicitly state that a particular claim is “PATENTABLE” or “HAVING REASONS FOR REFUSAL”, the applicant must include an explanation accompanying the request for participation in the PPH pilot program that no rejection has been made in the KIPO office action regarding that claim, and therefore, the claim is deemed allowable by the KIPO.

The office action includes:

- (i) *Notice of Grounds for Rejection*
- (ii) *Decision of Rejection*
- (iii) *Decision to grant a patent.*

The above office action (i) - (iii) may be issued in the substantive examination procedure, the re-examination procedure, or the appeal procedure.

For the USPTO application(s), the allowable/patentable claims are

- (i) The claims shown in the item of “The allowed claim(s) is/are ___” in “Notice of Allowability” of “*Notice of Allowance and Fees Due*”;
- (ii) The claims shown in the item of “Claim(s) ___ is/are allowed” in “Office Action Summary” of “*Non-Final Rejection*” or “*Final Rejection*”;
- (iii) The claims¹ shown in the item of “Claim(s) ___ is/are objected to” in “Office Action Summary” of “*Non-Final Rejection*” or “*Final Rejection*” and the USPTO examiner indicates that the claims are objected to as being dependent upon a rejected base claim, but would be allowable/patentable if rewritten in independent

¹ When a claim is rejected and the USPTO examiner indicates in the Office action that certain features of the allowable/patentable invention have not been claimed and if properly claimed such claim may be given favorable consideration, the suggested and hypothetical claims are not regarded as allowable/patentable in this programme.

form including all of the limitations of the base claim and any intervening claims.

- (c) All claims in the CNIPA application (for which an accelerated examination under the IP5 PPH pilot programme is requested), as originally filed or as amended, must sufficiently correspond to one or more of those claims determined to be patentable/allowable in the corresponding application filed with another IP5 Office.**

Claims are considered to “sufficiently correspond” where, accounting for differences due to translations and claim format, the claims in the CNIPA application are of the same or similar scope as the claims in the corresponding application filed with another IP5 Office, or the claims in the CNIPA application are narrower in scope than the claims in the corresponding application filed with another IP5 Office. In this regard, a claim that is narrower in scope occurs when a claim in the corresponding application filed with another IP5 Office is amended to be further limited by an additional technical feature that is supported in the specification (description and/or claims). A claim in the CNIPA application which introduces a new/different category of claims to those claims determined to be patentable/allowable in the corresponding application filed with another IP5 Office is not considered to sufficiently correspond. For example, the claims in the corresponding application filed with another IP5 Office only contain claims to a process of manufacturing a product, then the claims in the CNIPA application are not considered to sufficiently correspond if the claims in the CNIPA application introduce product claims that are dependent on the corresponding process claims.

It is not necessary to include “all” claims determined to be patentable/allowable in the corresponding application filed with another IP5 Office in the CNIPA application (the deletion of claims is allowable). For example, in the case where the corresponding application filed with another IP5 Office contains 5 claims determined to be patentable/allowable, the CNIPA application may contain only 3 of these 5 claims.

Any claims amended or added after the grant of the request for participation in the PPH pilot programme need to sufficiently correspond to the claims indicated as patentable/allowable in the corresponding application filed with another IP5 Office when applicants have not received any office action related to substantive examination. Any claims amended or added after the grant of the request for participation in the PPH pilot programme need not to sufficiently correspond to the claims indicated as patentable/allowable in the corresponding application filed with another IP5 Office when applicants need to amend claims in order to overcome the reasons for refusal raised by examiners. Any amendment outside of the claim correspondence requirement is subject to examiners’ discretion.

Note that any applicant to the CNIPA may amend the application including its claims on its or his own initiative when a request for substantive examination is made, and within the

time limit of three months after the receipt of the *Notice of Invention Patent Application Entering into Substantive Examination Stage*. Therefore, an applicant needs to care about the time limit of amendment in order to make claims in the CNIPA application correspond to the claims determined to be patentable/allowable in the corresponding application filed with another IP5 Office.

(d) *The CNIPA application must have been published.*

The applicant must have received the *Notice of Publication of Invention Patent Application* issued from the CNIPA before, or when, filing the PPH request.

(e) *The CNIPA application must have entered into the substantive examination stage.*

The applicant must have received the *Notice of Invention Patent Application Entering into Substantive Examination Stage* issued from the CNIPA before, or when, filing the PPH request.

Note that as an exception, the applicant may file a PPH request simultaneously with the *Request for Substantive Examination*.

(f) *The CNIPA has not begun examination of the application at the time of request for the PPH.*

The applicant should have not received any office action issued from the substantive examination departments in the CNIPA before, or when, filing the PPH request.

(g) *The CNIPA application must be electronic patent application.*

2. Documents to be submitted

Documents (a) to (d) below must be submitted by attaching to “*Request for Participation in the Patent Prosecution Highway Pilot Programme*”.

Note that even when it is not needed to submit certain documents below, the names of the documents must be listed in the “*Request for Participation in the Patent Prosecution Highway Pilot Programme*” (Please refer to the example form below for the details).

(a) *Copies of all office actions (which are relevant to substantive examination for patentability in another IP5 Office, including search report, search opinion) which were issued for the corresponding application by another IP5 Office, and translations of them.*

Either Chinese or English is acceptable as translation language. If it is impossible for the

examiner to understand the translated office action, the examiner can request the applicant to resubmit translations.

(b) Copies of all claims determined to be patentable/allowable in the corresponding application by another IP5 Office, and translations of them.

Either Chinese or English is acceptable as translation language. If it is impossible for the examiner to understand the translated claims, the examiner can request the applicant to resubmit translations.

(c) Copies of references cited by the examiner in another IP5 Office

The documents to be submitted are those cited in the above-mentioned office actions. Documents which are only referred to as references and consequently do not consist of the reasons for refusal do not have to be submitted.

If the references are patent documents, the applicant doesn't have to submit them. When the CNIPA does not possess the patent document, the applicant has to submit the patent document at the examiner's request. Non-patent literature must always be submitted.

The translations of the references are unnecessary.

(d) Claim correspondence table

The applicant requesting PPH must submit a claim correspondence table, which indicates how all claims in the CNIPA application sufficiently correspond to the patentable/allowable claims in the corresponding application(s) filed with another IP5 Office.

When claims are just literal translation, the applicant can just write down that "they are the same" in the table. When claims are not just literal translation, it is necessary to explain the sufficient correspondence of each claim based on the criteria 1. (c) (Please refer to the example form below).

When the applicant has already submitted above documents identified in (a) to (c) to the CNIPA through simultaneous or past procedures, the applicant may incorporate the documents by reference and does not have to attach them. The names of the documents omitted for submission must still be listed in the "*Request for Participation in the Patent Prosecution Highway Pilot Programme*" with the date of submission.

When the above documents identified in (a) or (b) are available via the Dossier Access System (DAS)², the applicant does not need to submit a copy thereof, unless otherwise requested by the CNIPA. The names of the documents omitted for submission must still be listed in the

² For the EPO, it's European Patent Register via <https://register.epoline.org/espacenet/regviewer>; for the JPO, it's AIPN; for the KIPO, it's K-PION; and for the USPTO, it's Public Pair via <http://portal.uspto.gov/external/portal/pair/>.

“Request for Participation in the Patent Prosecution Highway Pilot Programme”.

Machine translations will be admissible for the documents identified in (a) and (b). The examiner can request applicants to submit an accurate translation, if the machine translation is insufficient. If the corresponding application(s) in another IP5 Office is (are) unpublished, the applicant must submit the documents identified in (a) and (b) above upon filing the PPH request.

3. “Request for Participation in the Patent Prosecution Highway Pilot Programme” for filing request of an accelerated examination under the IP5 PPH pilot programme

(a) Circumstances

When an applicant files a request for an accelerated examination under the IP5 PPH pilot programme to the CNIPA, the applicant must submit a request form *“Request for participation in the Patent Prosecution Highway Pilot Programme”*.

The applicant must indicate that the application is included in (i) to (iv) of 1.(a), and that the accelerated examination is requested under the PPH pilot programme. The application number, publication number, or a patent number of the corresponding application(s) in another IP5 Office also must be written.

In the case that the application which has one or more claims that are determined to be patentable/allowable is different from the application(s) included in (i) to (iv) of 1.(a) (for example, the divisional application of the basic application), the application number, publication number, or a patent number of the application(s) which has/have claims determined to be patentable/allowable and the relationship between those applications also must be written.

(b) Documents to be submitted

The applicant must list all required documents mentioned above 2. in an identifiable way, even when the applicant omits to submit certain documents.

(c) Notice

An applicant can file the *“Request for Participation in the Patent Prosecution Highway Pilot Programme”* to the CNIPA through on-line procedures only.

4. Procedure for the accelerated examination under the PPH pilot programme

The CNIPA decides whether the application can be entitled to the status for an accelerated examination under the PPH when it receives a request with the documents stated above. When

the CNIPA decides that the request is acceptable, the application is assigned a special status for an accelerated examination under the PPH.

In those instances where the request does not meet all the requirements set forth above, the applicant will be notified and the defects in the request will be identified. The applicant may be given opportunity, one time only, to correct certain specified defects. If the request is not approved, the applicant may resubmit the request up to one time. If the resubmitted request is still not approved, the applicant will be notified and the application will await action in its regular turn.

Part II
PCT-PPH using the PCT international work products from the EPO, JPO,
KIPO or USPTO

Applicants can request accelerated examination by a prescribed procedure including submission of relevant documents on an application which is filed with the CNIPA and satisfies the following requirements under the IP5 PPH pilot programme based on PCT international work products from the EPO, JPO, KIPO or USPTO (PCT-PPH pilot programme).

When filing a request for the PCT-PPH pilot programme, an applicant must submit a request form “*Request for Participation in the Patent Prosecution Highway Pilot Programme*” to the CNIPA.

1. Requirements

In order to be eligible to participate in the IP5 PPH pilot programme at the CNIPA, the following requirements must be met:

- (1) The latest work product in the international phase of a PCT application corresponding to the application (“international work product”), namely the Written Opinion of International Searching Authority (WO/ISA), the Written Opinion of International Preliminary Examining Authority (WO/IPEA) or the International Preliminary Examination Report (IPER), indicates at least one claim as patentable/allowable (The claim(s) determined as novel, inventive and industrially applicable by the ISA and/or IPEA has/have the meaning of patentable/allowable for the purposes of this document.).**

Note that the ISA and the IPEA which produced the WO/ISA, WO/IPEA and the IPER are limited to the EPO, JPO, KIPO and USPTO, but, if priority is claimed, the priority claim can be to an application in any Office, see example A' in Annex II (application ZZ can be any national application).

The applicant cannot file a request under PCT-PPH on the basis of an International Search Report (ISR) only.

In case any observation is described in Box VIII of WO/ISA, WO/IPEA or IPER which forms the basis of a PCT-PPH request, the application will not be eligible for participating in the PCT-PPH pilot programme.

- (2) The relationship between the application and the corresponding international application satisfies one of the following requirements:**

- (A) The application is a national phase application of the corresponding international**

application. (See Figures A, A', and A'' in Annex II)

- (B) The application is a national application as a basis of the priority claim of the corresponding international application. (See Figure B in Annex II)
- (C) The application is a national phase application of an international application claiming priority from the corresponding international application. (See Figure C in Annex II)
- (D) The application is a national application claiming foreign/domestic priority from the corresponding international application. (See Figure D in Annex II)
- (E) The application is the derivative application (divisional application and application claiming domestic priority etc.) of the application which satisfies one of the above requirements (A) – (D). (See Figures E1 and E2 in Annex II)

- (3) All claims, as originally filed or as amended, for examination under the PCT-PPH must sufficiently correspond to one or more of those claims indicated to be patentable/allowable in the latest international work product of the corresponding international application by the EPO, JPO, KIPO, or USPTO as ISA/IPEA.

Claims are considered to "sufficiently correspond" where, accounting for differences due to translations and claim format, the claims of the application are of the same or similar scope as the claims indicated to be patentable/allowable in the latest international work product, or the claims of the application are narrower in scope than the claims indicated to be patentable/allowable in the latest international work product.

In this regard, a claim that is narrower in scope occurs when a claim indicated to be patentable/allowable in the latest international work product is amended to be further limited by an additional feature that is supported in the specification (description and/or claims) of the application.

A claim of the application which introduces a new/different category of claims to those claims indicated to be patentable/allowable in the latest international work product is not considered to sufficiently correspond. For example, the claims indicated to be patentable/allowable in the latest international work product only contain claims to a process of manufacturing a product, then the claims of the application are not considered to sufficiently correspond if the claims of the application introduce product claims that are dependent on the corresponding process claims.

It is not necessary to include "all" claims determined to be patentable/allowable in the corresponding international application in an application in the CNIPA (the deletion of claims is allowable). For example, in the case where the corresponding international application contains 5 claims determined to be patentable/allowable, the application in the CNIPA may contain only 3 of these 5 claims.

Any claims amended or added after the grant of the request for participation in the PCT-PPH

pilot programme need to sufficiently correspond to the claims indicated as patentable/allowable in the latest international work product when applicants have not received any office action related to substantive examination. Any claims amended or added after the grant of the request for participation in the PCT-PPH pilot programme need not to sufficiently correspond to the claims indicated as patentable/allowable in the latest international work product when applicants need to amend claims in order to overcome the reasons for refusal raised by examiners. Any amendment outside of the claim correspondence requirement is subject to examiners' discretion.

Note that any applicant to the CNIPA may amend the application including its claims on its or his own initiative when a request for substantive examination is made, and within the time limit of three months after the receipt of the *Notice of Invention Patent Application Entering into Substantive Examination Stage*. Therefore, an applicant needs to care about the time limit of amendment in order to make claims in the CNIPA application correspond to claims determined to be patentable/allowable in the latest international work product.

(4) The application must have been published.

The applicant must have received the *Notice of Publication of Invention Patent Application* issued from the CNIPA before, or when, filing the PPH request.

(5) The application must have entered into substantive examination stage.

The applicant must have received the *Notice of Invention Patent Application Entering into Substantive Examination Stage* issued from the CNIPA before, or when, filing the PPH request. Note that as an exception, the applicant may file a PPH request simultaneously with the *Request for Substantive Examination*.

(6) The CNIPA has not begun examination of the application at the time of request for the PCT-PPH.

The applicant should have not received any office action issued from the substantive examination departments in the CNIPA before, or when, filing the PCT-PPH request.

(7) The application must be electronic patent application.

2. Documents to be submitted

Documents (1) to (4) below must be submitted by attaching to "*Request for Participation in the Patent Prosecution Highway Pilot Programme*".

Note that even when it is not needed to submit certain documents below, the names of the

documents must be listed in the “*Request for Participation in the Patent Prosecution Highway Pilot Programme*” (Please refer to the example form below for the details).

(1) A copy of the latest work product in the international phase of the corresponding PCT application, the WO/ISA or, where a demand under PCT Chapter II has been filed, the WO/IPEA or the IPER which indicated the claims to be patentable/allowable and their Chinese or English translations.

In case the application satisfies the relationship 1.(2)(A), the applicant need not submit a copy of the *International Preliminary Report on Patentability* (IPRP) because a copy of this document is already contained in the file-wrapper of the application. In addition, if the copy of the latest international work product is available via PATENTSCOPE³, the applicant need not submit these documents, unless otherwise requested by the CNIPA. (WO/ISA and IPER are usually available as “IPRP Chapter I” and “IPRP Chapter II” respectively in 30 months after the priority date.)

If it is impossible for the examiner to understand the translated international work product, the examiner can request the applicant to resubmit translations.

(2) A copy of a set of claims which the latest international work product of the corresponding international application indicated to be patentable/allowable and their Chinese or English translations.

If the copy of the set of claims which are indicated as allowable/patentable is available via “PATENTSCOPE” (e.g. the international Patent Gazette has been published), the applicant need not submit this document, unless otherwise requested by the CNIPA.

If it is impossible for the examiner to understand the translated claims, the examiner can request the applicant to resubmit translations.

(3) A copy of references cited in the latest international work product of the corresponding international application.

Documents which are only referred to as references and consequently do not consist of the reasons for refusal do not have to be submitted.

If the reference is a patent document, the applicant is not required to submit it. In case the CNIPA has difficulty in obtaining the document, however, the applicant may be asked to submit it. Non-patent literature must always be submitted.

Translations of cited references are unnecessary.

(4) A claims correspondence table which indicates how all claims in the application

³ <http://patentscope.wipo.int>

sufficiently correspond to the claims indicated to be patentable/allowable in the corresponding international application.

When claims are just literal translation, the applicant can just write down that “they are the same” in the table. When claims are not just literal translation, it is necessary to explain the sufficient correspondence of each claim based on the criteria 1.(3) (Please refer to the Example form below).

When an applicant has already submitted the above mentioned documents (1)-(3) to the CNIPA through simultaneous or past procedures, the applicant may incorporate the documents by reference and is thus not required to attach the documents. The names of the documents omitted for submission must still be listed in the “*Request for Participation in the Patent Prosecution Highway Pilot Programme*” with the date of submission.

Machine translations will be admissible for the documents identified in (1) and (2). The examiner can request applicants to submit an accurate translation, if the machine translation is insufficient.

3. “Request for Participation in the Patent Prosecution Highway Pilot Programme” for filing request of an accelerated examination under the IP5 PCT-PPH pilot programme

(1) Circumstances

The applicant must indicate that the application is included in (A) to (E) of 1.(2), and that the accelerated examination is requested under the PCT-PPH pilot programme. The application number(s) of the corresponding international application(s) also must be written.

(2) Documents to be submitted

The applicant must list all required documents mentioned above 2. in an identifiable way, even when the applicant omits to submit certain documents.

(3) Notice

An applicant can file the “*Request for Participation in the Patent Prosecution Highway Pilot Programme*” to the CNIPA through on-line procedures only.

4. Procedure for the accelerated examination under the PCT-PPH pilot programme

The CNIPA decides whether the application can be entitled to the status for an accelerated examination under the PCT-PPH when it receives a request with the documents stated above. When the CNIPA decides that the request is acceptable, the application is assigned a special status for an accelerated examination under the PCT-PPH.

In those instances where the request does not meet all the requirements set forth above, the applicant will be notified and the defects in the request will be identified. The applicant may be given opportunity, one time only, to correct certain specified defects. If the request is not approved, the applicant may resubmit the request up to one time. If the resubmitted request is still not approved, the applicant will be notified and the application will await action in its regular turn.

Sample Form

参与专利审查高速路（PPH）试点项目请求表

PPH

Request for participation in the Patent Prosecution Highway (PPH) Pilot Program (Sample Form)

A. 著录数据	
申请号	
B. 请求	
申请人请求参与专利审查高速路（PPH）试点项目基于：	
在先审查局（OEE）	
OEE 工作结果类型	<input type="checkbox"/> 国家/地区的审查意见
	<input type="checkbox"/> WO-ISA, WO-IPEA 或 IPER
OEE 申请号	
本申请与 OEE 申请的关系	
C. 文件提交	
第 I 栏 OEE 工作结果及其所需译文	
1.	<input type="checkbox"/> 提交了 OEE 工作结果的副本 <input type="checkbox"/> 请求通过案卷访问系统或 PATENTSCOPE 获取上述文件
2.	<input type="checkbox"/> 提交了 1 之所述文件的译文 <input type="checkbox"/> 请求通过案卷访问系统或 PATENTSCOPE 获取上述文件
第 II 栏 OEE 认定为可授权的所有权利要求的副本及其所需译文	
3.	<input type="checkbox"/> 提交了 OEE 认定为可授权的所有权利要求的副本 <input type="checkbox"/> 请求通过案卷访问系统或 PATENTSCOPE 获取上述文件
4.	<input type="checkbox"/> 提交了 3 之所述文件的译文 <input type="checkbox"/> 请求通过案卷访问系统或 PATENTSCOPE 获取上述文件
第 III 栏 OEE 工作结果引用的文件	
5.	<input type="checkbox"/> 提交了 OEE 工作结果引用的所有文件的副本（专利文献除外） <input type="checkbox"/> 无引用文件
第 IV 栏 已提交文件	
6.	<input type="checkbox"/> 若上述某些文件已经提交，请予说明： 申请人于__年__月__日在 CN_____中提交了_____文件
D. 权利要求对应性	

<input type="checkbox"/> 本申请的所有权利要求与 OEE 申请中可授权的权利要求充分对应		
<input type="checkbox"/> 在下表中解释权利要求对应性		
本申请的权利要求	对应的 OEE 权利要求	关于对应性的解释

E. 说明事项

1. OEE 工作结果的副本名称如下：
 - a. OEE 申请_____；
 - 1) 由__于__年__月__日作出的_____
 - 2) 由__于__年__月__日作出的_____
2. OEE 工作结果引用的文件的副本名称如下：
 - 1) _____
 - 2) _____
3. 特殊项的解释说明：

申请人或其代理人	日期

ANNEX I

IP5: EPO, JPO, KIPO or USPTO

DO: Designated office

ZZ: Any office

A

A case meeting requirement (a) (i)
- Paris route -

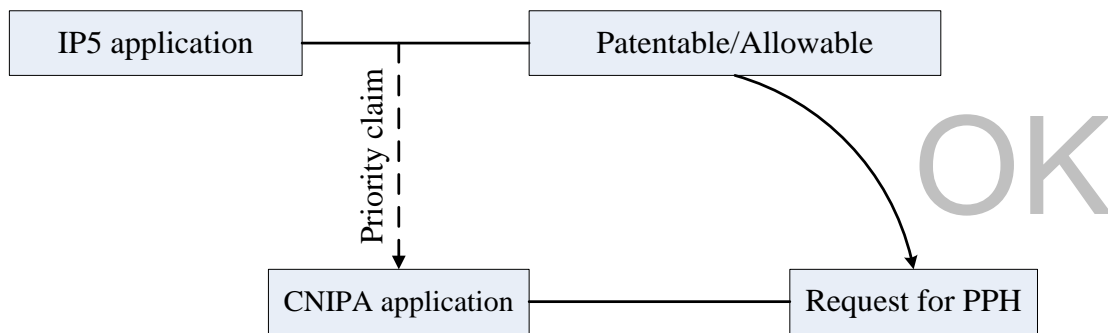

B

A case meeting requirement (a) (i)
- PCT route -

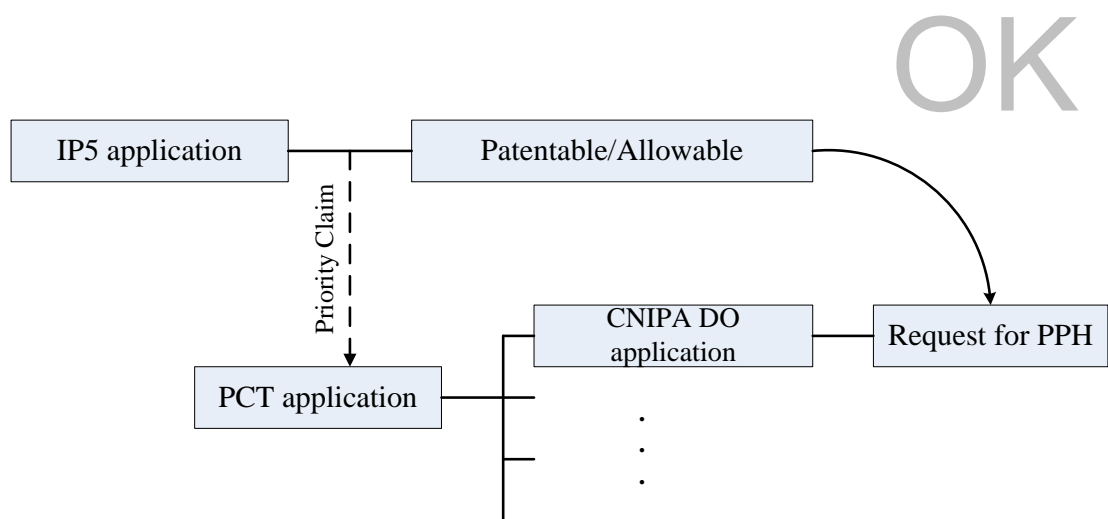

C

A case meeting requirement (a) (i)
- Paris route & complex priority -

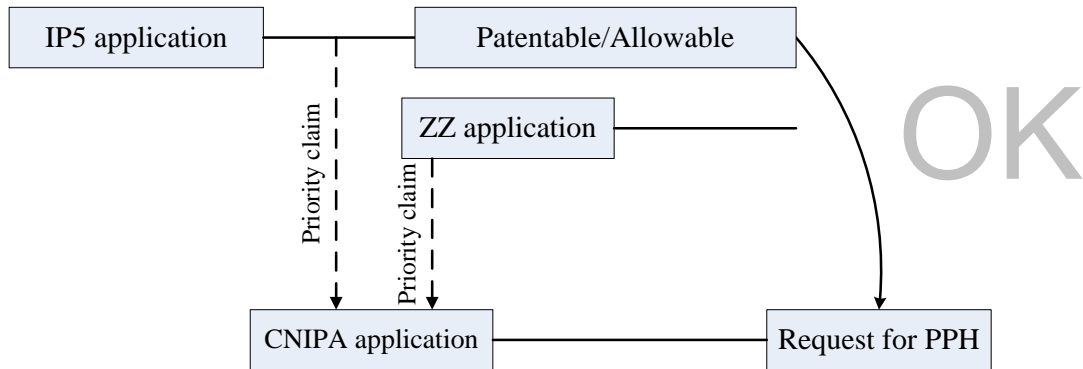

D

A case meeting requirement (a) (i)
- Paris route & divisional application -

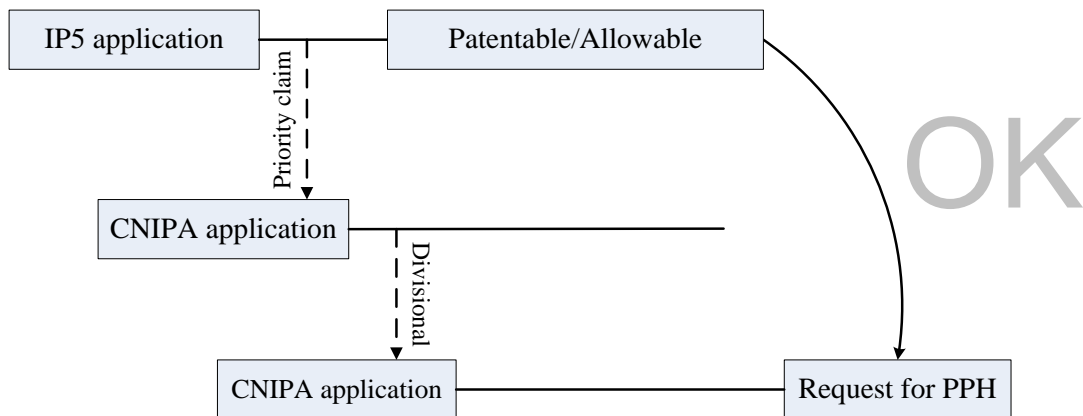

E

A case meeting requirement (a) (ii)
- Paris route -

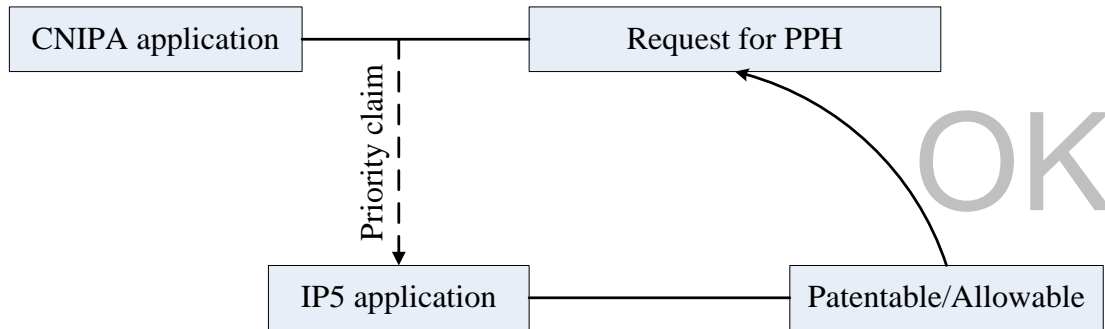

F

A case meeting requirement (a) (ii)
- PCT route -

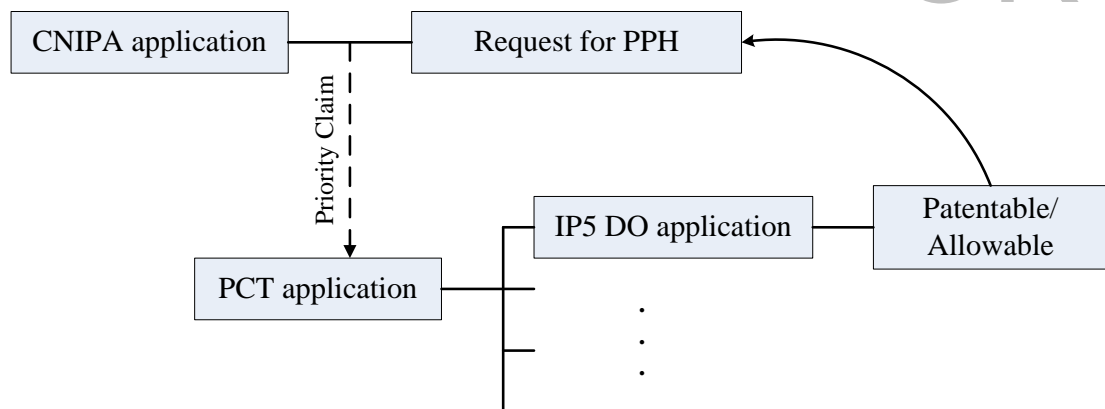

G

A case meeting requirement (a) (ii)
- Paris route & complex priority -

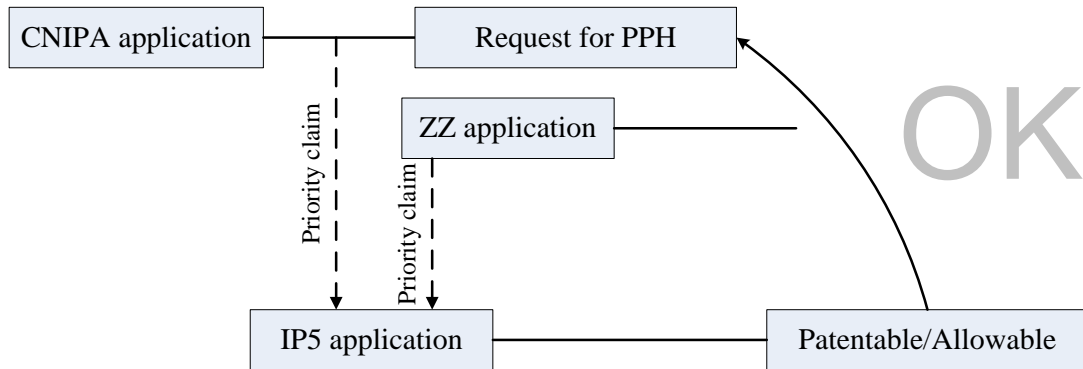

H

A case meeting requirement (a) (iii)
- Paris route, Domestic priority -

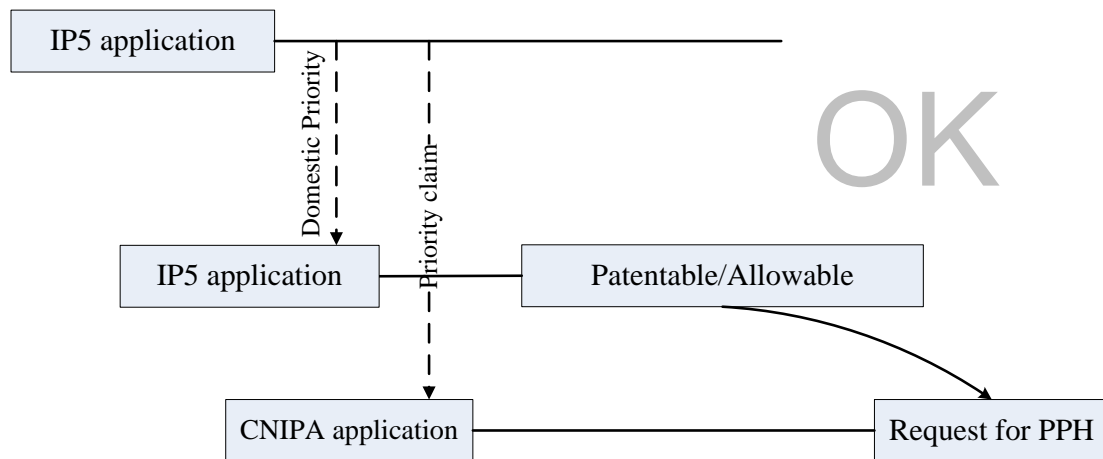

I

A case meeting requirement (a)(iii)

- Paris route, but the first application is from the third country -

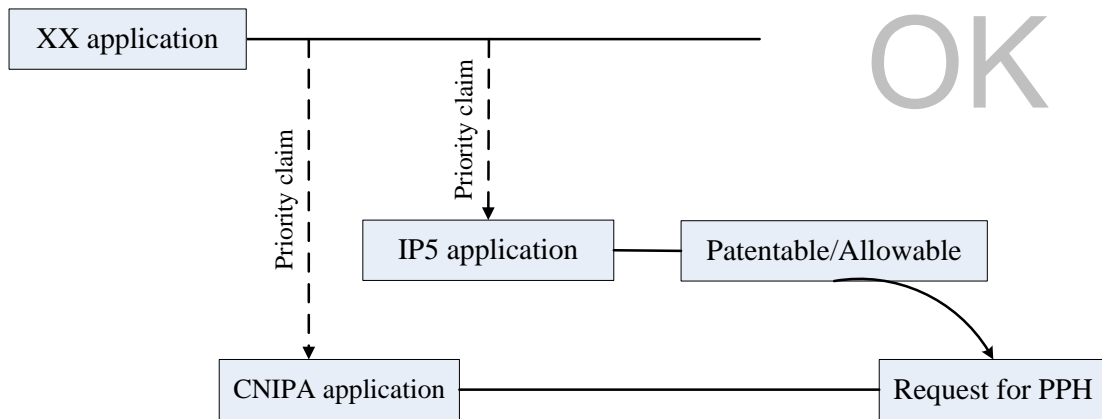

OK

J

A case meeting requirement (a)(iii)

- PCT route, but the first application is from the third country -

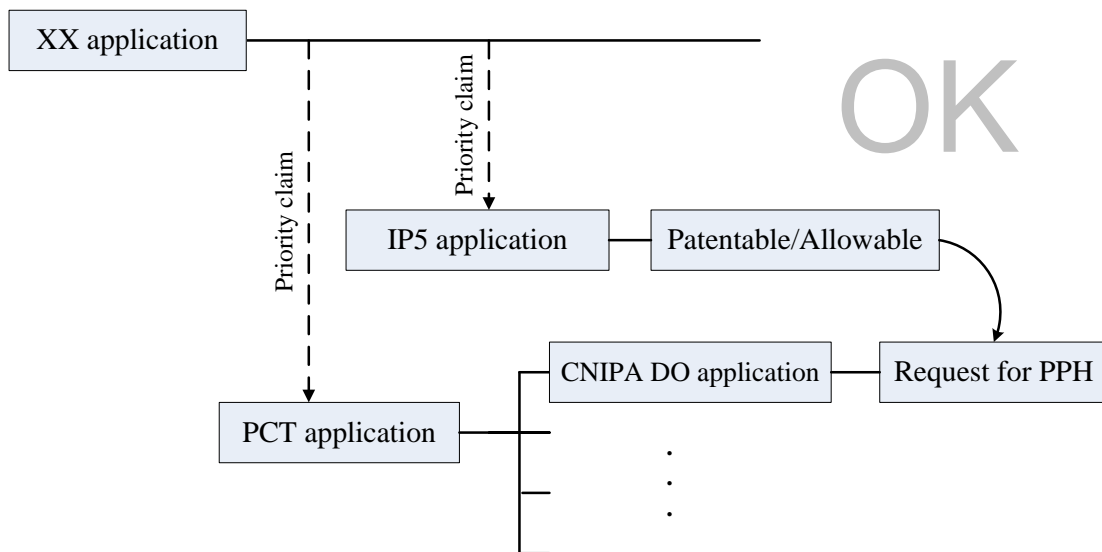

OK

K

A case meeting requirement (a) (iii)
- PCT route -

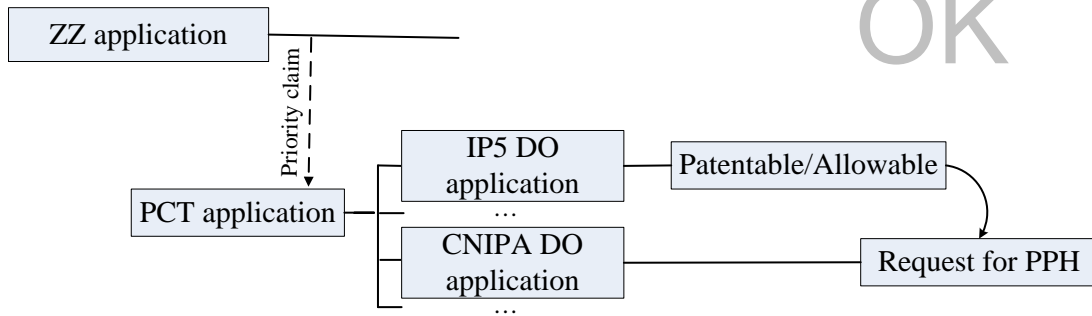

L

A case meeting requirement (a) (iii)
- Direct PCT & PCT route -

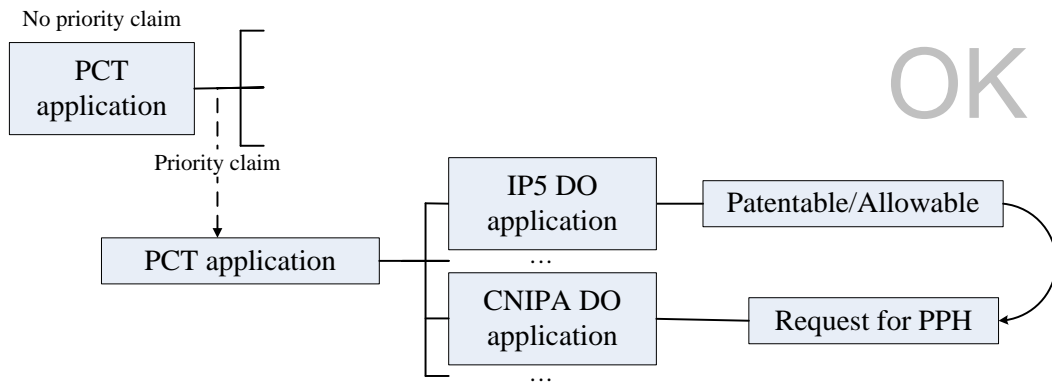

M

A case meeting requirement (a) (iv)
- Direct PCT route -

OK

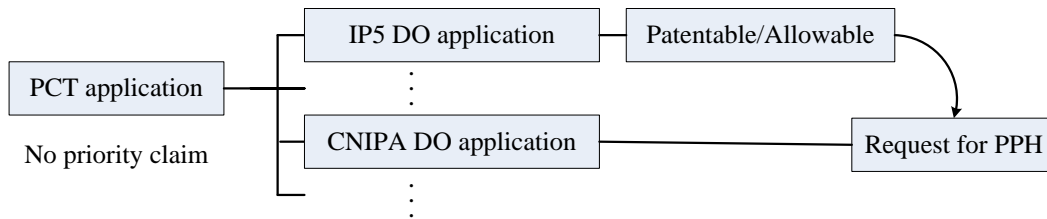

N

A case not meeting requirement (f)
- Examination has begun before a request for PPH -

NG

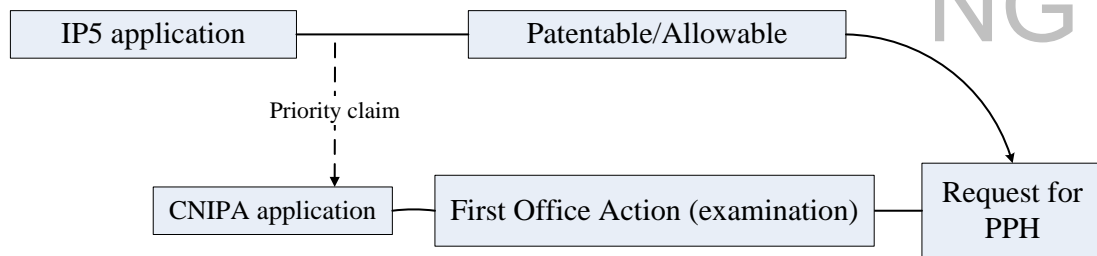

O

A case not meeting requirement (d)
- The application has not been published at the time of request for PPH -

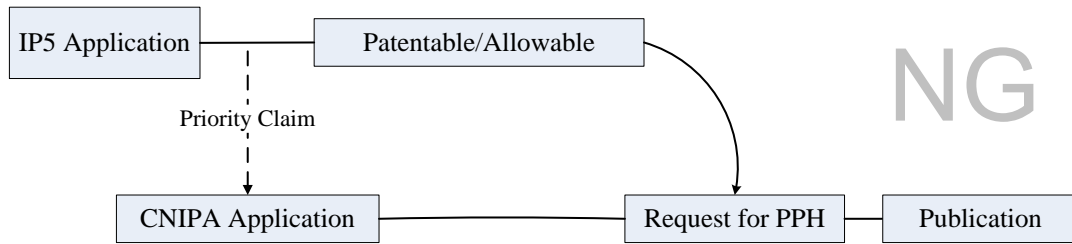

P

A case not meeting requirement (e)
- The application has not entered into substantive examination stage at the time of request for PPH -

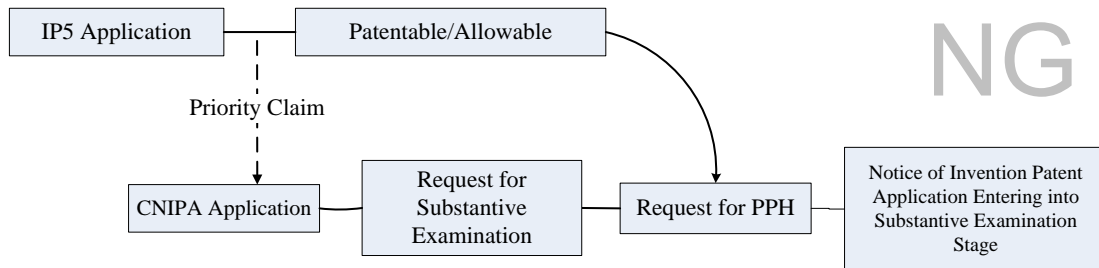

Q

A case meeting requirement (e) (exception) - PPH request simultaneously with the Request for Substantive Examination -

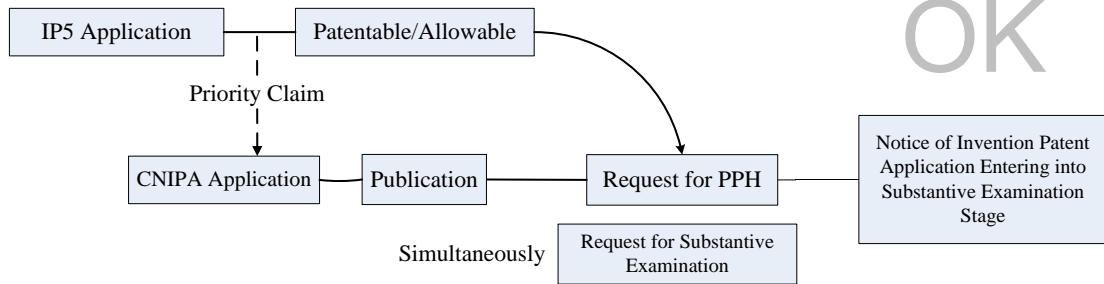

ANNEX II

IP5: EPO, JPO, KIPO or USPTO

DO: Designated office

ZZ: Any office

(A) The application is a national phase application of the corresponding international application.

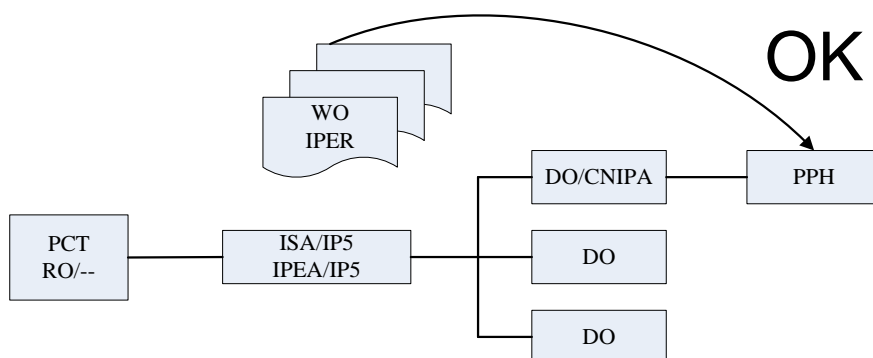

(A') The application is a national phase application of the corresponding international application. (The corresponding international application claims priority from a national application.)

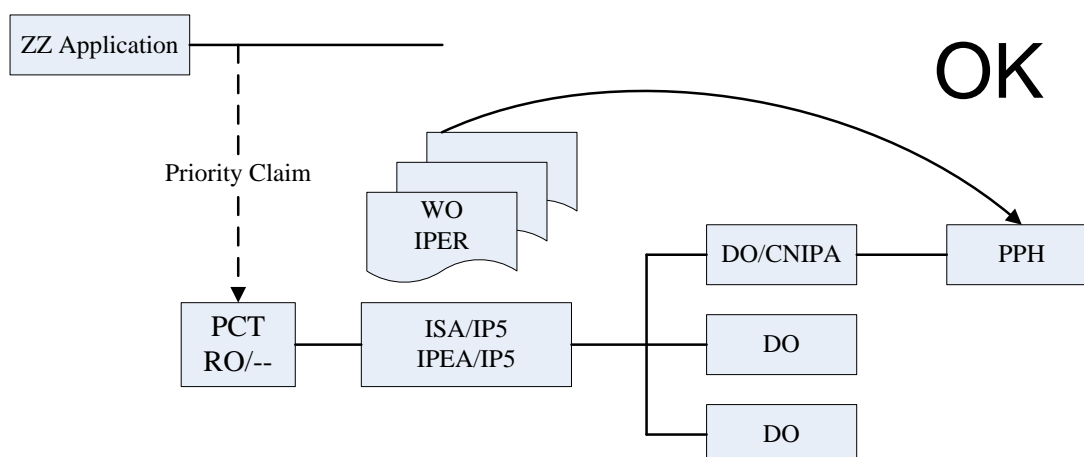

**(A'') The application is a national phase application of the corresponding international application.
(The corresponding international application claims priority from an international application.)**

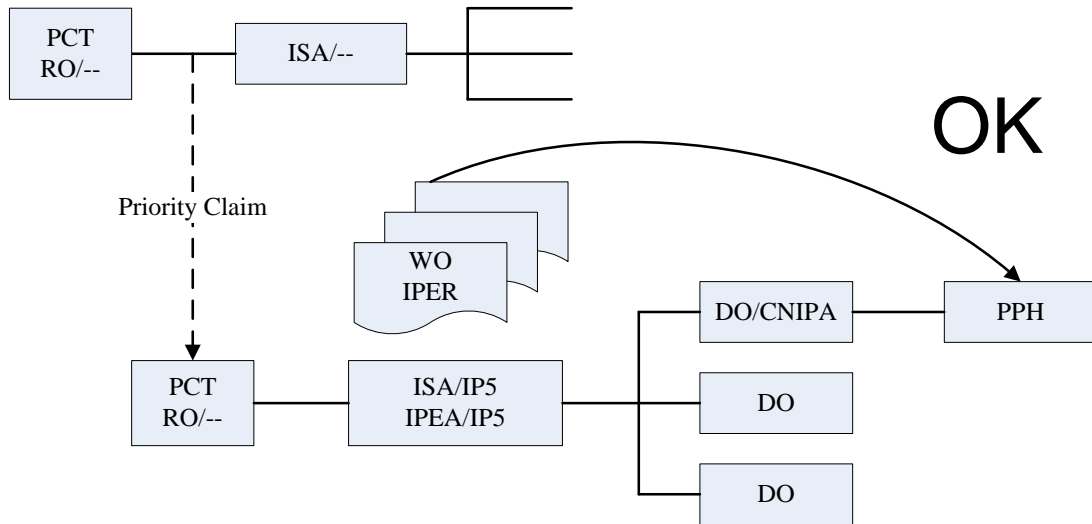

(B) The application is a national application as a basis of the priority claim of the corresponding international application.

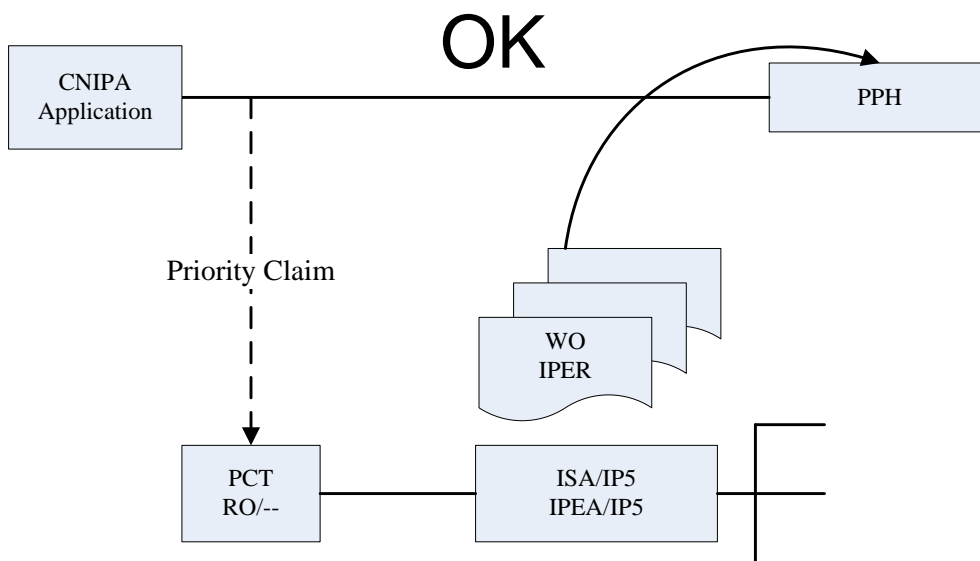

(C) The application is a national phase application of an international application claiming priority from the corresponding international application.

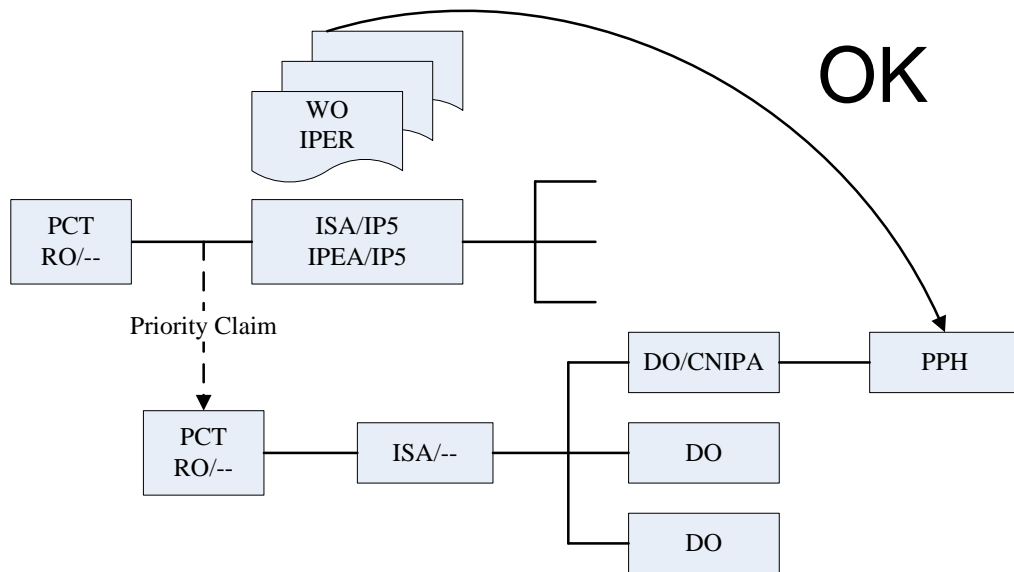

(D) The application is a national application claiming foreign/domestic priority from the corresponding international application.

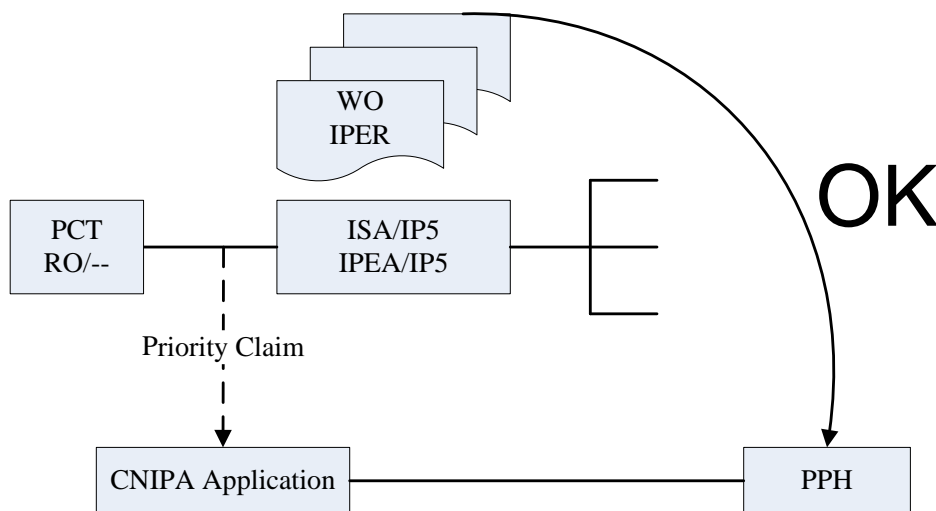

(E1) The application is a divisional application of an application which satisfies the requirement (A).

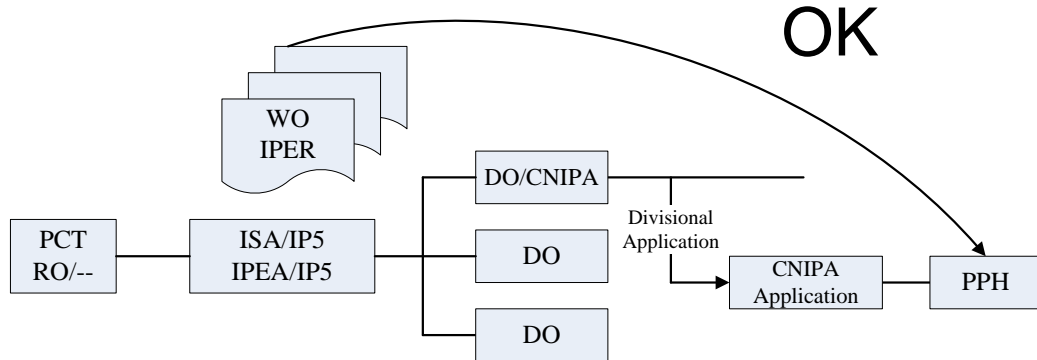

(E2) The application is an application claiming domestic priority from an application which satisfies the requirement (B).

