

## **Procedures to file a request to the INPI (the National Institute of Industrial Property in France) for Patent Prosecution Highway Pilot Program between the INPI and the JPO (Japan Patent Office)**

Applicants can request accelerated examination by a prescribed procedure including submission of relevant documents on an application which is filed with the INPI and satisfies the following requirements under the INPI-JPO Patent Prosecution Highway (PPH) pilot program based on the JPO application.

When filing a request for the PPH pilot program, an applicant must submit a request form to the INPI.

The offices may terminate the PPH pilot program if the volume of participation exceeds manageable level, or for any other reason. Ex Ante notice will be published if the PPH pilot program is terminated.

The PPH pilot program between INPI and JPO will commence on January 1, 2021 and will end on December 31, 2022 with mutual consent. However, the program may be extended after a joint INPI-JPO review and assessment of the program implementation.

### **1. Requirements**

**(a) *The INPI application is***

- (i) *an application which validly claims priority under the Paris Convention to the JPO application(s) (examples are provided in ANNEX, Figure A, B, D and E), or***
- (ii) *an application which validly claims priority under the Paris Convention to the PCT application(s) without priority claim (examples are provided in ANNEX, Figure F).***

The INPI application, which validly claims priority to multiple JPO or direct PCT applications, or which is the divisional application validly based on the originally filed application that is included in (i) to (ii) above, is also eligible.

**(b) *At least one corresponding application exists in the JPO and has one or more claims that are determined to be patentable by the JPO.***

The corresponding application(s) can be the application which forms the basis of the priority claim, an application which derived from the JPO application which forms the basis of the priority claim (e.g., a divisional application of the JPO application or an application which claims domestic priority to the JPO application (see Figure B in ANNEX)), or an JPO national phase application of a PCT application (see Figure F in ANNEX).

Claims are “determined to be patentable” when the JPO examiner clearly identified the claims to be patentable in the latest office action, even if the application is not granted for patent yet.

The office action includes one of the following:

- (a) Decision to Grant a Patent
- (b) Notification of Reasons for Refusal
- (c) Decision of Refusal
- (d) Appeal Decision

For example, if the following routine expression is described in the “Notification of Reason for Refusal” of the JPO, those claims are clearly identified to be patentable.

“<Claims which has been found no reason for refusal>

At present for invention concerning Claim\_\_\_, no reason for refusal is found.”

- (c) All claims on file, as originally filed or as amended, for examination under the PPH must sufficiently correspond to one or more of those claims indicated as patentable in the JPO.**

Claims are considered to “sufficiently correspond” where, accounting for differences due to translations and claim format, the claims in the INPI are of the same or similar scope as the claims indicated as patentable in the JPO, or the claims in the INPI are narrower in scope than the claims indicated as patentable in the JPO. In this regard, a claim that is narrower in scope occurs when a claim indicated as patentable in JPO is amended to be further limited by an additional feature that is supported in the specification (description and/or claims).

A claim in the INPI which introduces a new/different category of claims to those claims indicated as patentable in the JPO is not considered to sufficiently correspond. For example, where the claims indicated as patentable in JPO only contain claims to a process of manufacturing a product, then the claims in the INPI are not considered to sufficiently correspond if the INPI claims introduce product claims that are dependent on the corresponding process claims.

If the PPH request is granted, any claims amended or added after an office action need not to sufficiently correspond to the claims indicated as patentable in the JPO application.

- (d) The INPI has not begun the grant examination of the application at the time of request for the PPH.**

For a better acceleration of the examination process, the INPI recommends to file the request for the PPH within 12 months from the filing date of the INPI application.

## **2. Documents to be submitted**

Documents (a) to (d) below must be submitted by attaching to the PPH request form in filing a request under PPH.

**(a) Copies of all office actions (which are relevant to substantial examination for patentability in the JPO) which were issued for the corresponding application by the JPO, and translations of them<sup>1</sup>.**

Either French or English is acceptable as translation language. The applicant does not have to submit a copy of JPO office actions and translations of them when those documents are provided via JPO's dossier access system because the office actions and their machine translations are available for the INPI examiner via the JPO's dossier access system. If they cannot be obtained by the INPI examiner via the JPO's dossier access system, the applicant may be notified and requested to provide the necessary documents.

**(b) Copies of all claims determined to be patentable by the JPO, and translations of them.**

Either French or English is acceptable as translation language. The applicant does not have to submit a copy of claims indicated to be patentable in the JPO, and translations thereof when the documents are provided via JPO's dossier access system because they are available for the INPI examiner via the JPO's dossier access system. If they cannot be obtained by the INPI examiner via the JPO's dossier access system, the applicant may be notified and requested to provide the necessary documents.

**(c) Copies of references cited by the JPO examiner**

If the references are patent documents, the applicant doesn't have to submit them because the INPI usually possesses them. When the INPI does not possess the patent document, the applicant has to submit the patent document at the examiner's request. Non-patent literature must always be submitted.

The translations of the references are unnecessary.

**(d) Claim correspondence table**

The applicant must submit a claim correspondence table, which indicates how all claims in the INPI application sufficiently correspond to the patentable claims in the JPO application. When claims are just literal translation, the applicant can just write down that "they are the same" in the table. When claims are not just literal translation, it is necessary to explain the sufficient correspondence of each claim.

When the applicant has already submitted above documents (a) to (d) to the INPI through simultaneous or past procedures, the applicant may incorporate the documents by reference and does not have to attach them.

---

<sup>1</sup> Machine translations will be admissible, but if it is impossible for the examiner to understand the outline of the translated office action or claims due to insufficient translation, the applicant may be requested to resubmit translations.

### 3. Procedure for filing a PPH request

PPH requests must be submitted through INPI's online filing website:  
<https://procedures.inpi.fr/?/>

#### a) Filing a PPH request at the time of filing the patent application

The option to file a PPH request will appear in the "Revendication de Priorité" section once the priority of a Japanese application has been claimed.

The screenshot shows the 'OPTION : REVENDICATION DE PRIORITÉ' section. A green message box states 'La priorité n°1 a été ajoutée.' Below it, an information box explains that priority can be claimed for a foreign or French application within 12 months of the earliest filing date. A table lists the added priority:

#	N°	DATE DE DÉPÔT	PAYS	
1	2020-011111	01/01/2020	Japon	Modifier Supprimer

Below the table, there is a checkbox for 'Demande d'examen accéléré en vertu du PPH / Request for an accelerated examination under the PPH pilot program' which is currently unchecked (labeled 'Non').

Then you need to tick "Oui" (next to "Request for an accelerated examination under the PPH pilot program"), in order to trigger the possibility to provide the corresponding documents:

## PPH based on the JPO patent application

Demande d'examen accéléré en vertu du PPH / Request for an accelerated examination under the PPH pilot program

Oui

Joindre vos documents +	Copies of all office actions (which are relevant to substantial examination for patentability in the JPO) which were issued for the corresponding application by the JPO ( <i>copies de toutes les notifications de l'office (pertinentes pour l'examen substantif pour la brevetabilité au JPO) qui ont été envoyées pour la demande correspondante par le JPO</i> )
Joindre vos documents +	translations of them ( <i>leur traduction</i> )
Joindre vos documents +	Copies of all claims determined to be patentable by the JPO ( <i>Copies de toutes les revendications déterminées comme étant brevetables par le JPO</i> )
Joindre vos documents +	translations of them ( <i>leur traduction</i> )
Joindre vos documents +	Copies of references cited by the JPO examiner ( <i>Copies des références citées par l'examineur du JPO</i> )
Joindre vos documents +	Claim correspondence table ( <i>Table de correspondance des revendications</i> )*
<b>Details about omitted documents</b> ( <i>Explication à propos des documents non soumis</i> )	Explication à propos des documents non soumis...

Four documents must be submitted, as specified above (Cf. 2. Documents to be provided):

- Copies of the JPO's offices actions which are relevant to substantive examination for patentability (and their translation)
- Copies of all claims determined to be patentable by the JPO (and their translation)
- Copies of the references cited by the JPO Examiner
- Claim correspondence table

Warning: The provision of a claim correspondence table is mandatory for filing a PPH request. In addition, non-patent literature must always be submitted.

The field next to "Details about omitted documents" allows the applicant to specify the reasons why he didn't provide some of the documents (with the exception of the correspondence table, which must always be provided, as well as non-patent literature or any other document that is not accessible via the JPO's dossier access system).

When you click on "Joindre vos documents", then you can upload your documents:



Just click on "Parcourir", then upload the document in PDF format, and click on "Envoyer le document".

Finally, once all of the required documents have been uploaded, click on "Etape suivante" to continue the patent application procedure:

Joindre vos documents + Claim correspondence table (*Table de correspondance des revendications*)\*

<b>Details about omitted documents</b> <i>(Explication à propos des documents non soumis)</i>	Explication à propos des documents non soumis...
--	--

CRÉÉ LE	NOM	TYPE	CATEGORIE	ACTION
17/12/2020	TypeRR_29_07_2020_165032_FR1660034.pdf	PDF	Claim correspondence table / Table de correspondance des revendications	<div style="background-color: #c00; color: white; padding: 2px 5px; border-radius: 3px; display: inline-block;">  Supprimer         </div> <div style="background-color: #008080; color: white; padding: 2px 5px; border-radius: 3px; display: inline-block;">  Télécharger         </div>

Etape suivante >

At the end of the patent application filing process, when you see the filing summary ("Récapitulatif de dépôt"), you will be able to check the information concerning the PPH request and documents provided in the "Revendication de priorité" section:

OPTION : REVENDICATION DE PRIORITÉ 1
Modifier

*	N°	DATE DE DÉPÔT	PAYS
1	2020-011111	01/01/2020	Japon

Demande d'examen accéléré en vertu du PPH / Request for an accelerated examination under the PPH pilot program Oui

CRÉÉ LE	NOM	TYPE	CATEGORIE	ACTION
17/12/2020	TypeRR_29_07_2020_165032_FR1660034.pdf	PDF	Claim correspondence table / Table de correspondance des revendications	<span style="background-color: #cc0000; color: white; padding: 2px 5px; margin-right: 5px;">Supprimer</span> <span style="background-color: #009999; color: white; padding: 2px 5px;">Télécharger</span>

OPTION : DEMANDE DE DÉLIVRANCE ACCÉLÉRÉE
Modifier

Je sollicite la délivrance accélérée de ma demande en 20 mois du dépôt. À cette fin, je sollicite également la publication anticipée de la demande. Je suis informé(e) que ma demande de brevet ou de certificat d'utilité doit remplir plusieurs conditions pour être délivrée en 20 mois Non

Filing a PPH request is free of charge.

**b) Filing a PPH request after the filing of the INPI patent application**

It is still possible to file a PPH request at any time after the filing of the patent application, as long as the INPI has not begun the grant examination of the application (cf. 1 d)).

Simply click on "Transmettre un document" under "Mes actions":

REQUÊTE

Titre	Demande de brevet conforme aux exigences antérieures au standard xml	Extension Polynésie Française	Non	Réduction de redevance	Non	Demande de délivrance accélérée	Non
Type	Brevet français	Séquences de nucléotides et/ou d'acides aminés	Non				
	Demande de brevet provisoire		Non				

INTERVENANTS

TYPE -	NOM -
--------	-------

DEMANDE

Réf. I.N.P.I. : FR2030124	
N° de publication :	
Votre réf. :	
Date de dépôt : 17/12/2020	

MES ACTIONS

Transmettre un document <span style="float: right;">▶</span>	
Demander la	

Then click on "Parcourir" and upload all of the documents related to the PPH request, in PDF format :

## PPH based on the JPO patent application

DOCUMENTS
Annuler

Attention, les fichiers ne peuvent excéder la taille de **100.00 Mo** et doivent appartenir au(x) type(s) **.pdf** et **.txt**  
 Les types « Description », « Revendications », « Dessins », « Texte d'abrégé » et « Dessin d'abrégé » doivent être utilisés pour les versions sans modifications apparentes.  
 La version avec les modifications apparentes doit être fournie en tant que courrier d'accompagnement ou dans le courrier d'accompagnement.

Parcourir...

REÇU LE	NOM	TYPE	ACTION
17/12/2020	application-body.xml	Contenu de la demande XML	<a href="#">Télécharger</a>
17/12/2020	Demande_redige_compatible XML.docx.zip	Contenu de la demande ZIP	<a href="#">Télécharger</a>
17/12/2020	Demande_redige_compatible XML.docx.pdf	Contenu de la demande PDF	<a href="#">Télécharger</a>
17/12/2020	Demande_redige_compatible XML.docx	Contenu de la demande DOCX	<a href="#">Télécharger</a>

Once the documents have been uploaded, please select "Requête PPH (pour priorité JP uniquement) / PPH Request (for JP priority only)" for the "Type", then click on "Envoyer le document":

DOCUMENTS
Envoyer le document Annuler

Attention, les fichiers ne peuvent excéder la taille de **100.00 Mo** et doivent appartenir au(x) type(s) **.pdf** et **.txt**  
 Les types « Description », « Revendications », « Dessins », « Texte d'abrégé » et « Dessin d'abrégé » doivent être utilisés pour les versions sans modifications apparentes.  
 La version avec les modifications apparentes doit être fournie en tant que courrier d'accompagnement ou dans le courrier d'accompagnement.

NOM	TYPE *	FORMAT	TAILL
TypeRR_29_07_2020_165032_FR1660034.pdf	Requête PPH (pour priorité JP uniquement) / PPH request (for JP priority only)	.pdf	25

The uploaded document can be seen in the "Documents" section:



## PPH based on the JPO patent application

DOCUMENTS				
		<a href="#">+ Ajouter un document</a>	<a href="#">+ Demander la correction d'une erreur matérielle</a>	<a href="#">+ Demander un erratum</a>
REÇU LE	NOM	TYPE	ACTION	
17/12/2020	TypeRR_29_07_2020_165032_FR1660034.pdf	Requête PPH (pour priorité JP uniquement) / PPH request (for JP priority only)	<a href="#">Télécharger</a>	
17/12/2020	application-body.xml	Contenu de la demande XML	<a href="#">Télécharger</a>	
17/12/2020	Demande_redige_compatible XML.docx.zip	Contenu de la demande ZIP	<a href="#">Télécharger</a>	
17/12/2020	Demande_redige_compatible XML.docx.pdf	Contenu de la demande PDF	<a href="#">Télécharger</a>	
17/12/2020	Demande_redige_compatible XML.docx	Contenu de la demande DOCX	<a href="#">Télécharger</a>	

All of the documents related to the PPH request have to be uploaded under the "Requête PPH (pour priorité JP uniquement) / PPH Request (for JP priority only)" type.

Five documents must be submitted, as specified above (Cf. 2. Documents to be provided):

- the PPH Request Form provided below (please see 4. PPH Request Form), which is mandatory for processing the PPH request
- Copies of the JPO's offices actions which are relevant to substantive examination for patentability (and their translation)
- Copies of all claims determined to be patentable by the JPO (and their translation)
- Copies of the references cited by the JPO Examiner
- Claim correspondence table

**Warning:** In this case, the provision of a PPH request form and claim correspondence table are mandatory for completing the filing of a PPH request. In addition, non-patent literature must always be provided.

The documents will then be automatically dispatched to the examiners.

Filing a PPH request is free of charge.

**4. PPH request form - Formulaire de requête PPH (en cas de dépôt sous priorité Japonaise uniquement)**

Request for an accelerated examination under the PPH pilot program - Requête pour un examen accéléré via le programme pilote PPH entre l'INPI et le JPO

Date of filing (*Date de dépôt*) : \_\_\_\_\_

INPI Application number (*Numéro de dépôt de la demande INPI*) : \_\_\_\_\_

Corresponding JPO Application number (*Numéro de la demande de brevet JPO correspondante*) : \_\_\_\_\_

\_\_\_\_\_

Documents submitted (*Documents soumis*) :

- Copies of all office actions (which are relevant to substantial examination for patentability in the JPO) which were issued for the corresponding application by the JPO and (*Copies de toutes les notifications du JPO (pertinentes pour l'examen de la brevetabilité) qui ont été envoyées pour la demande correspondante par le JPO et*)
- translations of them (*leur traduction*)
- Copies of all claims determined to be patentable by the JPO and (*Copies de toutes les revendications déterminées comme étant brevetables par le JPO et*)
- translations of them (*leur traduction*)
- Copies of references cited by the JPO examiner (*Copies des références citées par l'examineur du JPO*)
- Claim correspondence table (*Table de correspondance des revendications*)

Claim correspondence table ( <i>Table de correspondance des revendications</i> )		
The claim in the INPI ( <i>Revendications de la demande INPI</i> )	The patentable claim in the JPO ( <i>Revendications brevetables de la demande JPO</i> )	Comments about the correspondence ( <i>Commentaires sur la correspondance</i> )

(Documents to be omitted to submit – *Explication à propos des documents non fournis*) :

---



---



---



---



---

**A** A case meeting requirement (a) (i)  
- Paris route -

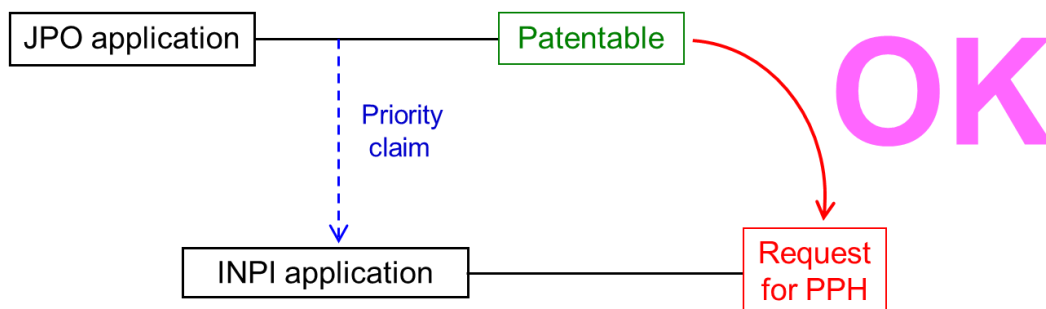

**B** A case meeting requirement (a) (i)  
- Paris route, Domestic priority -

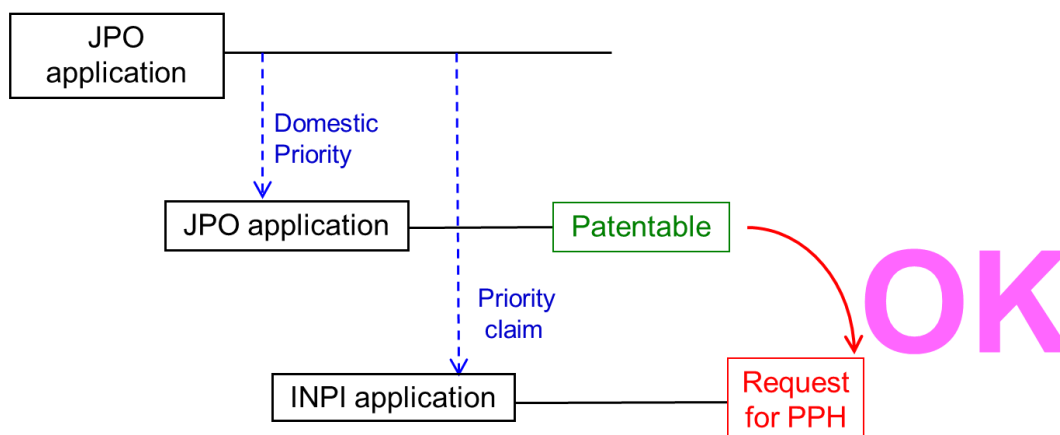

**C** A case not meeting requirement (a)  
- Paris route, but the first application is from the third country -

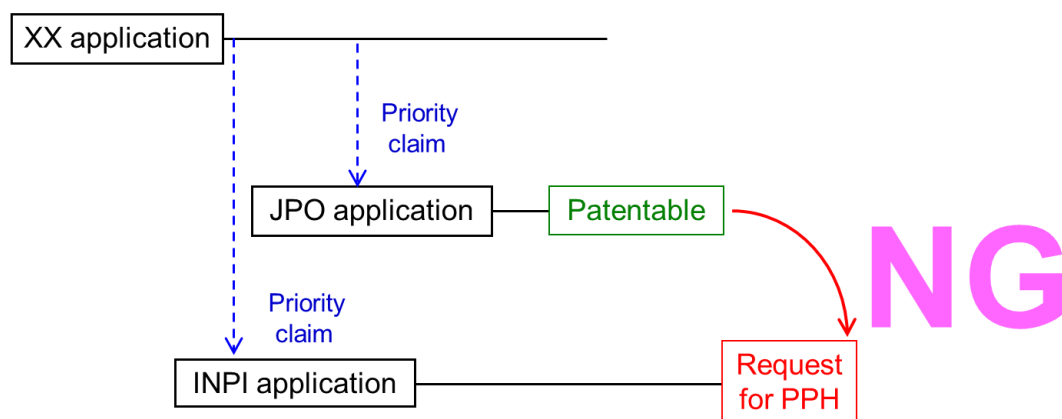

XX : the office other than the JPO and INPI

**D** A case meeting requirement (a) (i)  
- Paris route & Complex priority -

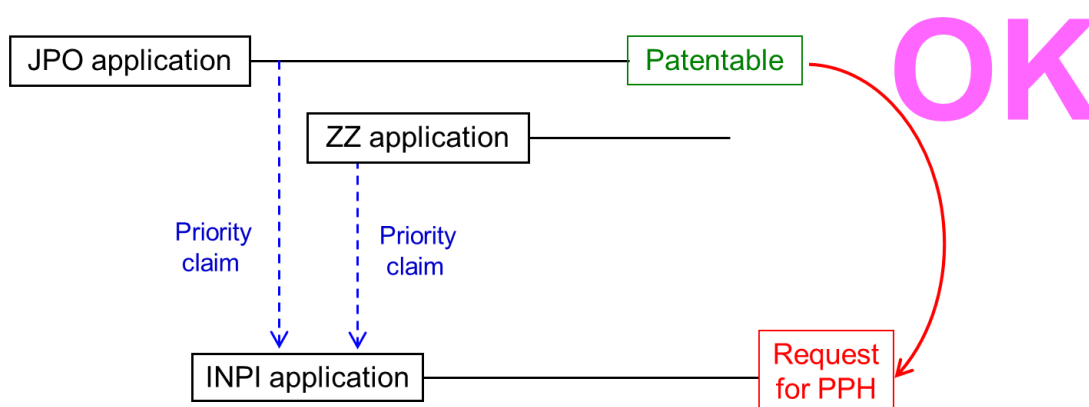

ZZ : any office

**E** A case meeting requirement (a) (i)  
- Paris route & divisional application -

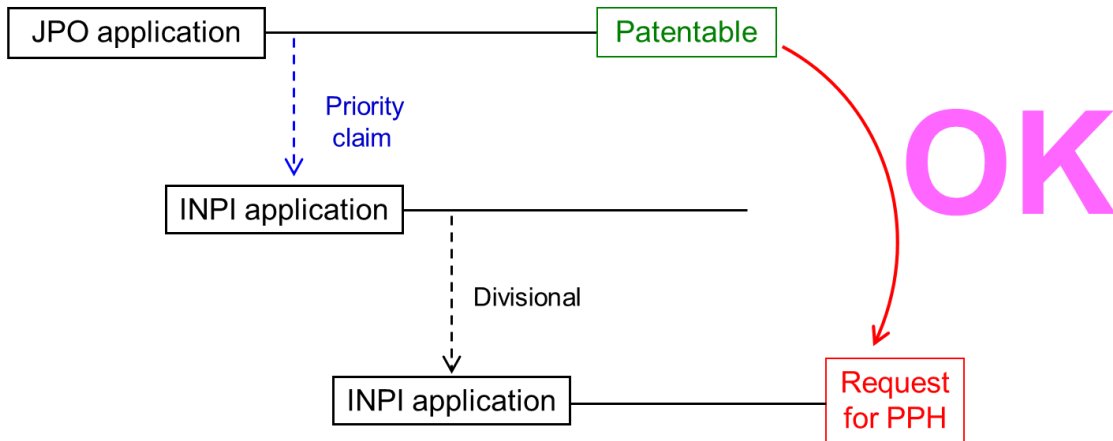

**F** A case meeting requirement (a) (ii)  
- Direct PCT & Paris route -

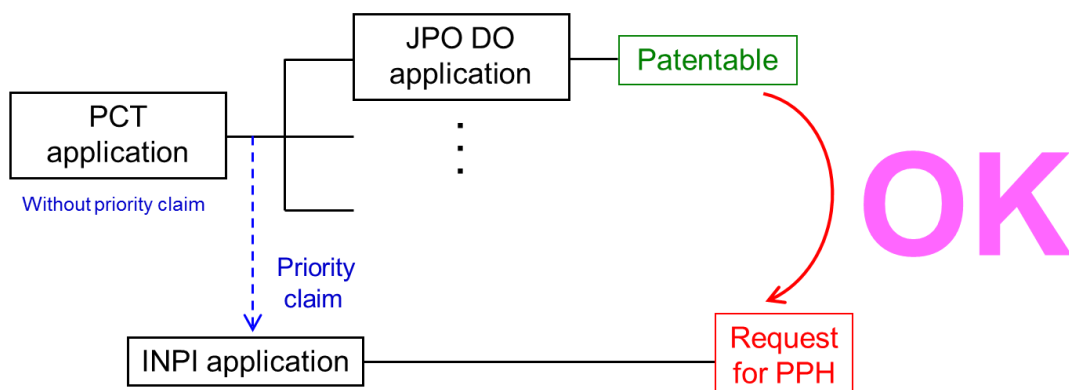

# G A case not meeting requirement (d)

- Examination has begun before a request for PPH -

