

**Procedures to file a request to the Moroccan Office of Industrial and
Commercial Property (OMPIC)
for Patent Prosecution Highway Pilot Program
between the OMPIC and the Japan Patent Office (JPO)**

Applicants can request accelerated examination by a prescribed procedure including submission of relevant documents on an application which is filed with the OMPIC and satisfies the following requirements under the OMPIC-JPO Patent Prosecution Highway (PPH) pilot program based on the JPO application.

When filing a request for the PPH pilot program, an applicant must submit, to the OMPIC, the request form PPH-JPO (see Annex 2) available on OMPIC's website at : <http://www.ompic.org.ma/fr/content/patent-prosecution-highway>.

The PPH pilot program between the OMPIC and the JPO will commence on April 1st, 2024 and will end with mutual consent. The offices may terminate the PPH pilot program if the volume of participation exceeds manageable level, or for any other reason. Ex Ante notice will be published if the PPH pilot program is terminated.

PPH using the national work products from the JPO

1. Requirements

- (a) Both the OMPIC application on which PPH is requested and the JPO application(s) forming the basis of the PPH request shall have the same earliest date (whether this be a priority date or a filing date).**

For example, the OMPIC application (including PCT national phase application) may be either:

- (i)** an application which validly claims priority under the Paris Convention from the JPO application(s) (examples are provided in ANNEX 1, Figures A, B, C, H, I and J), or
- (ii)** an application which provides the basis of a valid priority claim under the Paris Convention for the JPO application(s) (including PCT national phase application(s)) (examples are provided in ANNEX 1, Figures D and E), or
- (iii)** an application which shares a common priority document with the JPO application(s) (including PCT national phase application(s)) (examples are provided in ANNEX 1, Figures F, G, L, M and N), or
- (iv)** a PCT national phase application where both the OMPIC application and the JPO application(s) are derived from a common PCT international application having no priority claim (an example is provided in ANNEX 1, Figure K).

The OMPIC application, which validly claims priority to multiple JPO or direct PCT applications, or which is the divisional application validly based on the originally filed application that is included in (i) to (iv) above, is also eligible.

The pilot program is not applicable on the basis of JPO 'utility model' applications.

- (b) At least one corresponding application exists in the JPO and has one or more claims that are determined to be patentable/allowable by the JPO.**

The corresponding application(s) can be the application which forms the basis of the priority claim, an application which derived from the JPO application which forms the basis of the priority claim (e.g., a divisional application of the JPO application or an application which claims domestic priority to the JPO application (see Figure C in ANNEX 1), or an JPO national phase application of a PCT application (see Figures J, K, L, M and N in ANNEX 1).

Claims are "determined to be allowable/patentable" when the JPO examiner clearly identified the claims to be allowable/patentable in the latest office action, even if the application is not granted for patent yet.

The office action includes one of the following:

- (a) Decision to Grant a Patent

- (b) Notification of Reasons for Refusal
- (c) Decision of Refusal
- (d) Appeal Decision

For example, if the following routine expression is described in the “Notification of Reason for Refusal” of the JPO, those claims are clearly identified to be allowable/patentable.

“<Claims which has been found no reason for refusal>

At present for invention concerning Claim ___, no reason for refusal is found.”

- (c) ***All claims on file, as originally filed or as amended, for examination under the PPH must sufficiently correspond to one or more of those claims indicated as allowable in the JPO.***

Claims are considered to “sufficiently correspond” where, accounting for differences due to translations and claim format, the claims in the OMPIC are of the same or similar scope as the claims in the JPO, or the claims in the OMPIC are narrower in scope than the claims in the JPO.

In this regard, a claim that is narrower in scope occurs when a JPO claim is amended to be further limited by an additional feature that is supported in the specification (description and/or claims).

A claim in the OMPIC which introduces a new/different category of claims to those claims indicated as allowable in the JPO is not considered to sufficiently correspond. For example, where the JPO claims only contain claims to a process of manufacturing a product, then the claims in the OMPIC are not considered to sufficiently correspond if the OMPIC claims introduce product claims that are dependent on the corresponding process claims.

If the PPH request is granted, any claims amended or added after an office action need not to sufficiently correspond to the claims indicated as patentable in the JPO application.

- (d) ***The OMPIC has not begun examination of the application at the time of request for the PPH (an example is provided in ANNEX 1, figure O).***

2. Documents to be submitted

Documents (a) to (d) below must be submitted by attaching to the PPH request.

- (a) ***Copies of all office actions (which are relevant to substantial examination for patentability in the JPO) which were issued for the corresponding application by the JPO, and translations of them.***

Either Arabic, French or English is acceptable as translation language. The applicant does not have to submit a copy of JPO office actions and translations of them when those documents are provided via JPO's dossier access system because the office actions and their machine translations are available for the OMPIC examiner via the JPO's dossier access system. If they cannot be obtained by the OMPIC examiner via the JPO's dossier access system, the applicant may be notified and requested to provide the necessary documents.

(b) Copies of all claims determined to be patentable/allowable by the JPO, and translations of them.

Either Arabic, French or English is acceptable as translation language. The applicant does not have to submit a copy of claims indicated to be allowable/patentable in the JPO, and translations thereof when the documents are provided via JPO's dossier access system because they are available for the OMPIC examiner via the JPO's dossier access system.

Regarding (a) and (b), if the OMPIC examiner cannot obtain the copy of office actions or claims, indicated to be allowable/patentable in the JPO, and translations thereof via the JPO's dossier access system, or if it is impossible for him to understand the office actions or the claims due to insufficient translation, the examiner can request the applicant to resubmit the copy of the office actions or claims and translations thereof.

(c) Copies of references cited by the JPO examiner

If the references are patent documents, the applicant doesn't have to submit them because the OMPIC usually possesses them. When the OMPIC does not possess the patent document, the applicant has to submit the patent document at the examiner's request. Non-patent literature must always be submitted with, if necessary, a translation into Arabic, French or English.

The translations of the patent references are unnecessary.

(d) Claim correspondence table

The applicant requesting PPH must submit a claim correspondence table, which indicates how all claims in the OMPIC application sufficiently correspond to the patentable/allowable claims in the JPO application.

When claims are just literal translation, the applicant can just write down that "they are the same" in the table. When claims are not just literal translation, it is necessary to explain the sufficient correspondence of each claim.

When the applicant has already submitted above documents (a) to (d) to the OMPIC through simultaneous or past procedures, the applicant may incorporate the documents by reference and does not have to attach them.

3. Procedure for accelerated examination under the PPH Pilot Program before the OMPIC

The applicant fills out the form PPH-JPO (see Annex 2) requesting accelerated examination under the PPH Pilot Program between JPO and OMPIC (the form PPH-JPO) available on the OMPIC website and submit all the relevant supporting documents mentioned above.

The request for accelerated examination is considered by the patent examiner in charge of the corresponding patent application.

If all the requirements referred to in point 1. above are met, and the relevant documents referred to in point 2. above are submitted, the examiner proceeds to an accelerated examination of the application.

If the examiner considers that one of the requirements is not met, and in the case of the failure by the applicant to comply with the said requirements within a time limit, the examiner informs the applicant that he is not allowed to benefit from the accelerated procedure according to the PPH and explains the reasons for this. Furthermore, the applicant may at any time, as long as OMPIC has not started the examination of the patent application, re-file a new request for accelerated examination under the PPH.

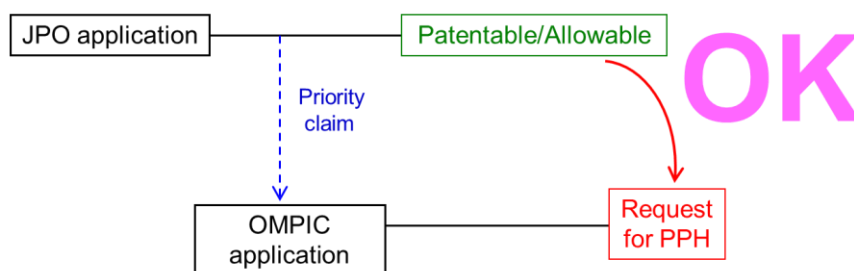
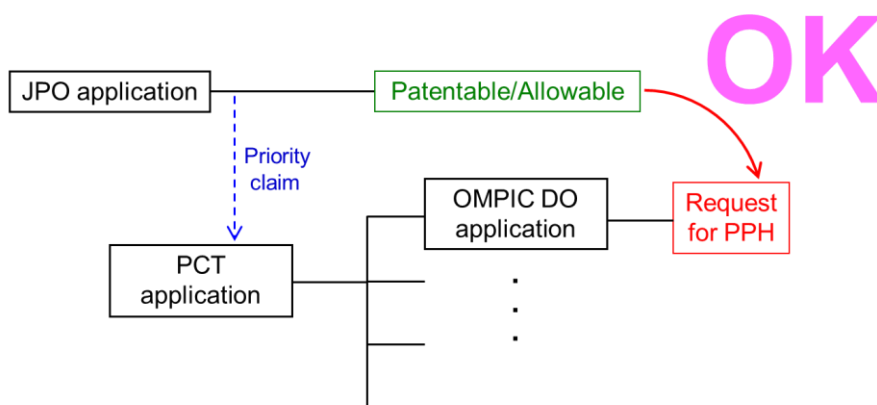
Annex 1**A** A case meeting requirement (a) (i)
- Paris route -**B** A case meeting requirement (a) (i)
- PCT route -

C A case meeting requirement (a) (i)
- Paris route, Domestic priority -

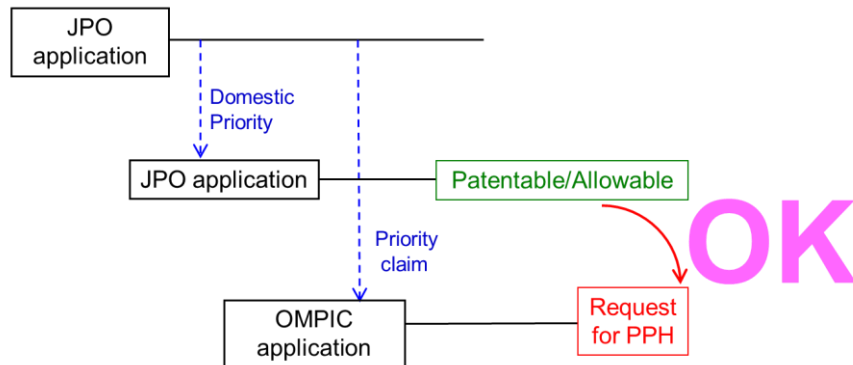

D A case meeting requirement (a) (ii)
- Paris route -

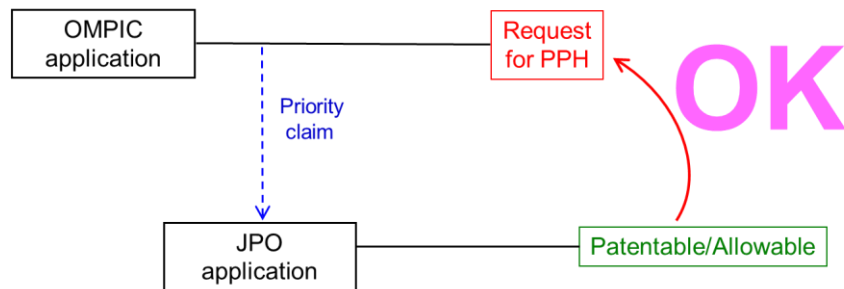

E A case meeting requirement (a) (ii)
- PCT route -

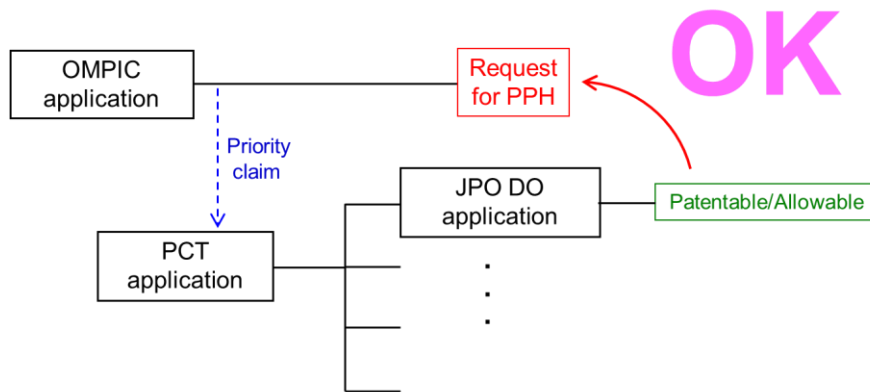

F A case meeting requirement (a) (iii)
- Paris route, but the first application is from the third country -

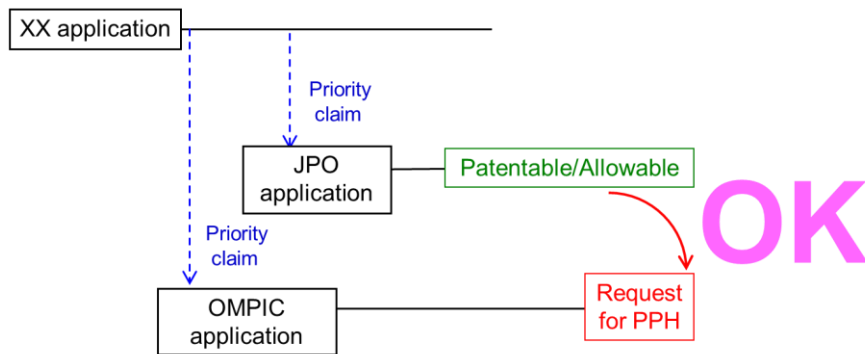

XX : the office other than the JPO

G

A case meeting requirement (a) (iii)

- PCT route, but the first application is from the third country -

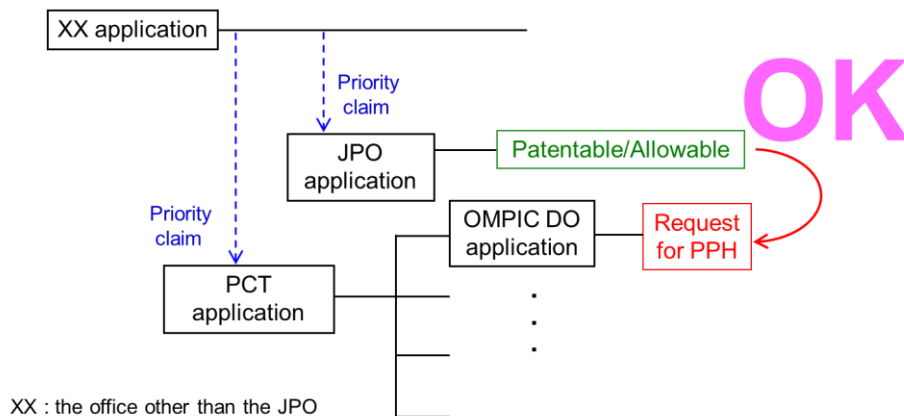

H

A case meeting requirement (a) (i)

- Paris route & Complex priority -

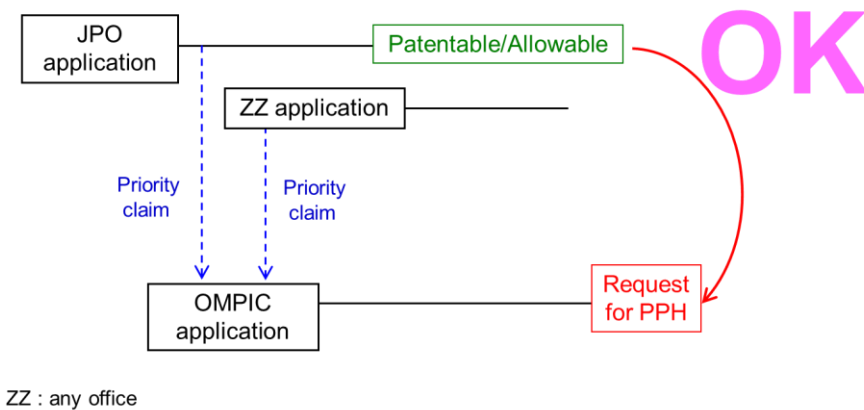

I A case meeting requirement (a) (i)
- Paris route & divisional application -

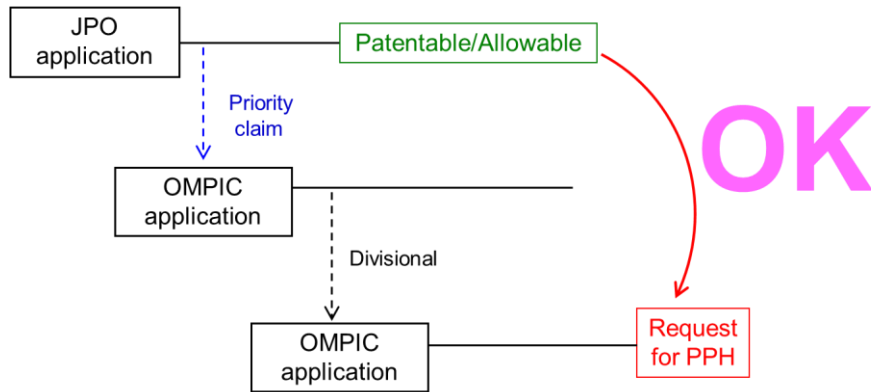

J A case meeting requirement (a) (i)
- PCT route -

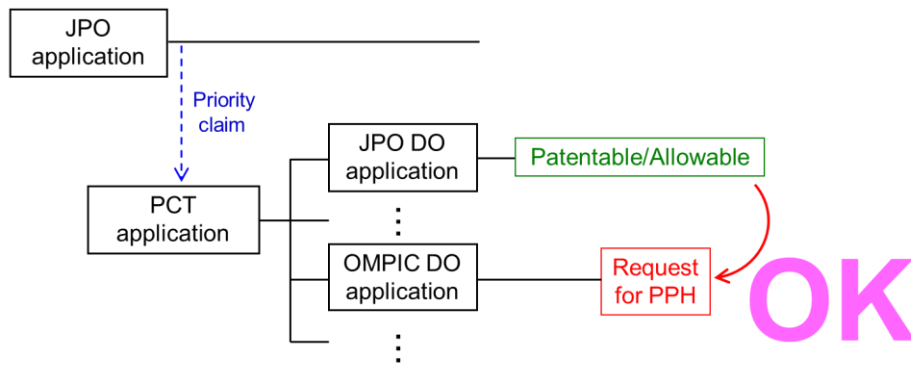

K A case meeting requirement (a) (iv)
- Direct PCT route -

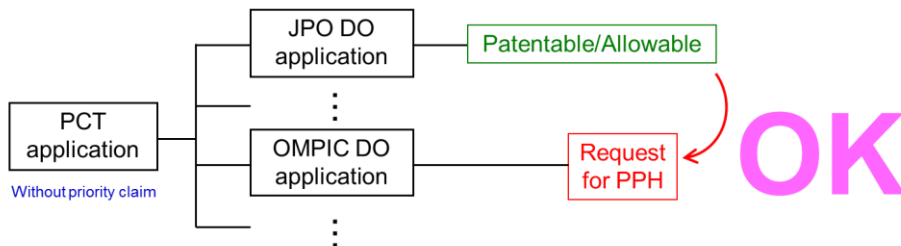

L A case meeting requirement (a) (iii)
- Direct PCT & Paris route -

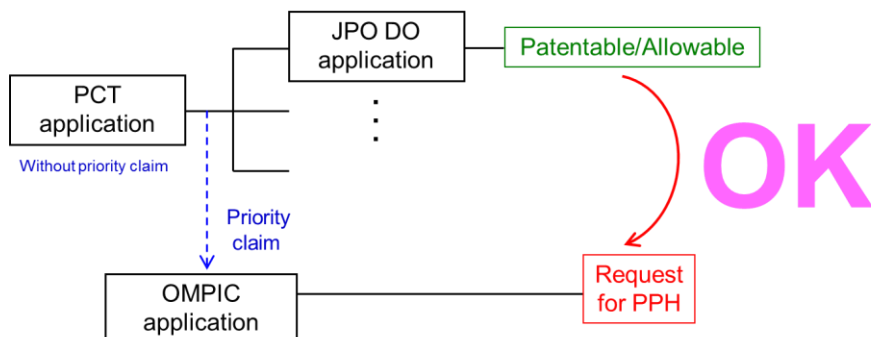

M A case meeting requirement (a) (iii)
- Direct PCT & PCT route -

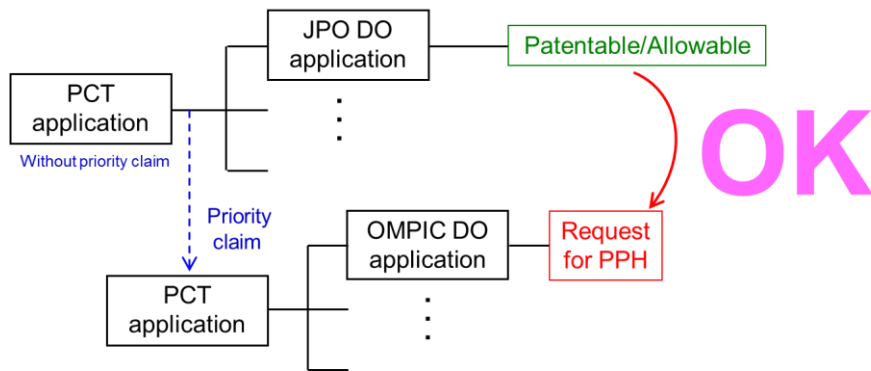

N A case meeting requirement (a) (iii)
- Direct PCT & PCT route -

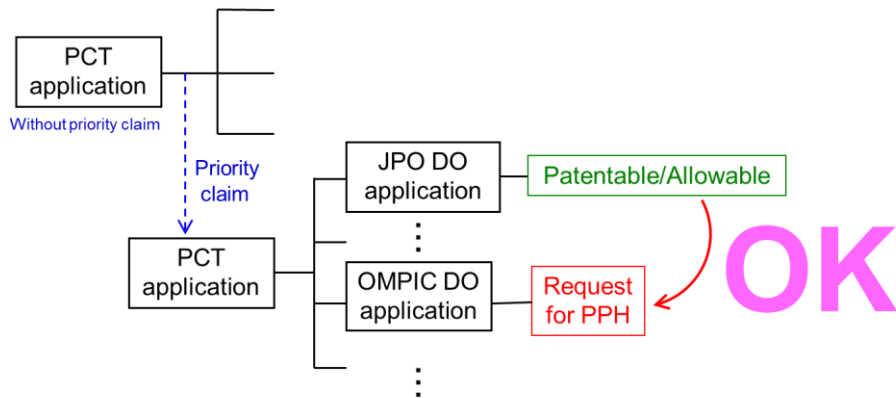

O A case not meeting requirement (d)
- Examination has begun before a request for PPH -

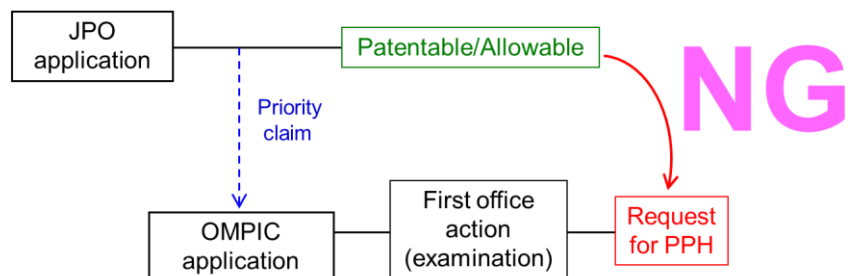

**BREVET D'INVENTION
FORMULAIRE DE DEMANDE D'EXAMEN ACCELERE
DANS LE CADRE DU PROGRAMME PILOTE PPH
ENTRE L'OMPIC ET LE JPO**

Version
Octobre 2020

PPH-JPO

Cet imprimé est à dactylographier lisiblement sans rayures ni surcharges

1 REFERENCES DE LA DEMANDE DE BREVET DEPOSEE AUPRES DE L'OMPIC		
Numéro de dépôt:		
Date de dépôt:		
2 DEPOSANT (En cas de plusieurs déposants n'en mentionner qu'un seul) :		
Dénomination sociale ou Nom & Prénom:		
3 MANDATAIRE (le cas échéant)		
<input type="checkbox"/> Conseiller en PI :		Adresse ⁽¹⁾ :
Nom & Prénom ou Dénomination sociale: Code :		
Représenté par:	CNI :	
Ville :		
<input type="checkbox"/> Autre :		Téléphone :
Dénomination sociale ou Nom & Prénom :		Télécopie :
ICE:	RC :	Tribunal :
ou CNI :		Email :
Représenté par:	CNI :	⁽¹⁾ L'adresse doit être libellée de la façon habituellement requise pour une distribution postale rapide et une bonne gestion des éventuelles notifications
4 REFERENCES DE LA DEMANDE DEPOSEE AUPRES DE JPO		
Numéro de dépôt:	Date de dépôt :	Date de priorité :
<input type="checkbox"/> La demande déposée à l'OMPIC et la ou les demandes correspondantes soumises au JPO, ont la même date de priorité ou de dépôt		
5 PIECES JOINTES		
<input type="checkbox"/> Copie de toutes les actions du JPO (qui sont pertinentes quant à la brevetabilité) <input type="checkbox"/> Traductions de toutes les actions du JPO <input type="checkbox"/> Copie des documents pertinents visés par l'examineur de JPO. <input type="checkbox"/> Copie des revendications jugées brevetables / acceptables par le JPO <input type="checkbox"/> Traductions des revendications jugées brevetables / acceptables <input type="checkbox"/> Pouvoir du mandataire, le cas échéant		
En cas de disponibilité de l'un des documents susmentionnés dans une base de données accessible par l'OMPIC, veuillez mentionner le document en question et le lien correspondant :		
Type de document	Lien vers une base de données accessible par l'OMPIC	
Nombre de pages composant la présente demande d'examen accéléré (Formulaires et pièces jointes) :		

REFERENCES DE LA DEMANDE DE BREVET DEPOSEE AUPRES DE L'OMPIC		
Numéro de dépôt:		
Date de dépôt:		
6. CORRESPONDANCE DES REVENDICATIONS		
<input type="checkbox"/> Toutes les revendications correspondent suffisamment aux revendications brevetables/acceptables de la demande de brevet soumise à JPO		
<input type="checkbox"/> TABLE DE CORRESPONDANCE DES REVENDICATIONS :		
Revendications de la demande de brevet déposée auprès de l'OMPIC	Revendications correspondantes soumises au JPO	commentaires expliquant la correspondance
<input type="checkbox"/> En cas de plusieurs revendications, utilisez l'imprimé suite « BS » et cochez cette case		
SIGNATURE DU DEMANDEUR, OU DE SON MANDATAIRE Le signataire certifie l'exactitude des informations figurant dans la présente demande		
DEMANDEUR Nom : Signature et qualité: Date :	MANDATAIRE Nom : Signature et qualité: Date :	

Annex 2 (reference translation in Japanese)

モロッコ王国

モロッコ産業商業財産権庁

OMPIC

発明特許

2020年10月作成

OMPIC-JPO PPH 試行プログラムにおける早期審査申請書

PPH-JPO

本書式は修正・加筆することなく、判読可能にタイプ記入すること

1. OMPICへの特許出願に関する情報	
出願番号：	
出願日：	
2. 出願人（複数人の場合は1名）：	
会社名又は氏名：	
3. 代理人（該当する場合）	
<input type="checkbox"/> 弁理士：	住所 ⁽¹⁾ ：
氏名又は会社名：	都市名： 居住国：
コード：	
代表者： 身分証明番号：	電話番号：
<input type="checkbox"/> その他：	Fax 番号：
会社名又は氏名：	E-mail：
コード：	⁽¹⁾ 住所は速達の配達及び通知の良好な管理に通常必要な内容を記載しなければならない。
会社識別番号： 商業登録番号： 管轄裁判所：	
又は身分証明番号：	
代表者： 身分証明番号：	
4. JPOへの出願に関する情報	
出願番号：	出願日： 優先日：
<input type="checkbox"/> OMPIC 出願と JPO 対応出願は同一の優先日又は出願日を有する。	
5. 添付書類	
<input type="checkbox"/> JPO のすべてのオフィスアクションの写し（特許性に関するもの） <input type="checkbox"/> JPO のすべてのオフィスアクションの翻訳文 <input type="checkbox"/> JPO 審査官が示した関連文献 <input type="checkbox"/> JPO により特許可能と判断された請求項 <input type="checkbox"/> 特許可能と判断された請求項の翻訳文 <input type="checkbox"/> 委任状（該当する場合） 上記のうちいずれかが OMPIC がアクセス可能なデータベースで入手可能な場合には、文書名とリンクを記載のこと 文書の種類 OMPIC がアクセス可能なデータベースへのリンク	
本早期審査申請書に含まれる枚数（申請書及び添付書類）：	

モロッコ王国

モロッコ産業商業財産権庁

OMPIC

2020年10月作成

PPH-JPO

OMPIC への特許出願に関する情報		
出願番号：		
出願日：		
1. 請求項の対応：		
<input type="checkbox"/> すべての請求項が JPO 出願の特許可能と判断された請求項に十分に対応している。 <input type="checkbox"/> 請求項対応表		
OMPIC 出願の請求項	JPO 出願の対応請求項	対応関係の説明
<input type="checkbox"/> 請求項数が多い場合には続紙「BS」を使用し当該ボックスをチェックすること。		
申請者又はその代理人の署名： 署名により、本申請書への記入事項の正確性が証明される		
申請者 氏名： 署名及び肩書： 日付：	代理人 氏名： 署名及び肩書： 日付：	