

Procedures to file a request to the JPO (Japan Patent Office) for Patent Prosecution Highway Pilot Program

Amended on July 6, 2020

Part I PPH using the national work products

Applicants can request accelerated examination by a prescribed procedure including submission of relevant documents on an application which is filed with the JPO and satisfies the following requirements under the Patent Prosecution Highway (PPH) pilot program based on the national work products from any one of the offices listed in Appendix A.

When filing a request for the PPH pilot program, an applicant must submit a request form “The Explanation of Circumstances Concerning Accelerated Examination” based on the procedure prescribed in “the Guidelines of the Accelerated Examination and Appeal”¹. Under the PPH pilot program, an applicant is not required to fill in the section “2. the disclosure of prior arts and comparison between the claimed invention and prior art” in “The Explanation of Circumstances Concerning Accelerated Examination”.

1. Requirements

(a) Both the JPO application on which PPH is requested and the Office of Earlier Examination (OEE) application(s) forming the basis of the PPH request shall have the same earliest date (whether this be a priority date or a filing date).²

For example, the JPO application (including PCT national phase application) may be either:

(Case I) an application which validly claims priority under the Paris Convention from the OEE application(s) (examples are provided in ANNEX I, Figures A, B, C, H, I and J), or

(Case II) an application which provides the basis of a valid priority claim under the Paris Convention for the OEE application(s) (including PCT national phase application(s)) (examples are provided in ANNEX I, Figures D and E), or

(Case III) an application which shares a common priority document with the OEE application(s) (including PCT national phase application(s)) (examples are provided in ANNEX I, Figures F, G, L, M and N), or

(Case IV) a PCT national phase application where both the JPO application and the

¹ <https://www.jpo.go.jp/e/system/patent/shinsa/jp-soki/document/index/guideline.pdf>

² The JPO application which corresponds to Korean utility model applications that have been subject to substantive examination under the New Act after 1st October 2006 also eligible for processing under the PPH.

OEE application(s) are derived from a common PCT international application having no priority claim (an example is provided in ANNEX I, Figure K).

(b) At least one corresponding application exists in the OEE and has one or more claims that are determined to be patentable/allowable by the OEE.

The corresponding application(s) can be the application which forms the basis of the priority claim, an application which derived from the OEE application which forms the basis of the priority claim (e.g., a divisional application of the OEE application), or a OEE national phase application of a PCT application.

See Appendix B in regard to concrete cases that claims are “determined to be patentable/allowable” on each OEEs.

(c) All claims in the JPO application (for which an accelerated examination under the PPH pilot program is requested) must sufficiently correspond to one or more of those claims determined to be patentable/allowable in the OEE.

Claims are considered to “sufficiently correspond” where, accounting for differences due to translations and claim format, the claims in the JPO are of the same or similar scope as the claims in the OEE, or the claims in the JPO are narrower in scope than the claims in the OEE. In this regard, a claim that is narrower in scope occurs when a OEE claim is amended to be further limited by an additional technical feature that is supported in the specification (description and/or claims). A claim in the JPO which introduces a new/different category of claims to those claims indicated as allowable in the OEE is not considered to sufficiently correspond. For example, where the OEE claims only contain claims to a process of manufacturing a product, then the claims in the OLE are not considered to sufficiently correspond if the JPO claims introduce product claims that are dependent on the corresponding process claims.

Any claims amended or added after the grant of the request for participation in the PPH pilot program need not to sufficiently correspond to the claims indicated as patentable/allowable in the OEE application.

(d) The JPO has not begun examination of the application at the time of request for the PPH (an example is provided in ANNEX I, Figure O).

(e) A “Request for Substantive Examination” must have been filed at the JPO either at the time of the PPH request or previously.

2. Documents to be submitted

Documents (a) to (d) below must be submitted by attaching to “The Explanation of Circumstances Concerning Accelerated Examination”.

Note that even when it is not needed to submit documents below, the name of the documents must be listed in “The Explanation of Circumstances Concerning Accelerated Examination” (Please refer to the Example form for the detail).

(a) Copies of all office actions (which are relevant to substantial examination for patentability in the OEE), which were sent for the corresponding application by the OEE, and translations of them.^{3,4}

Either Japanese or English is acceptable as translation language. Machine translation will be admissible, but if it is impossible for the examiner to understand the outline of the translated office action due to insufficient translation, the examiner can request the applicant to resubmit translations.

The applicant does not have to submit copies of the office actions when those documents are provided via OEE’s dossier access system⁵. If they cannot be obtained by the JPO examiner via the OEE’s dossier access system, the applicant may be notified and requested to provide them.

(b) Copies of all claims determined to be patentable/allowable by the OEE, and translations of them.²

Either Japanese or English is acceptable as translation language. Machine translations will be admissible, but if it is impossible for the examiner to understand the outline of the translated claims due to insufficient translation, the examiner can request the applicant to resubmit translations.

The applicant does not have to submit copies of all claims determined to be patentable/allowable when the documents are provided via OEE’s dossier access system⁵. If they cannot be obtained by the JPO examiner via the OEE’s dossier access system, the applicant may be notified and requested to provide them.

³ Where the CIPO is the OEE, an applicant can request an electronic copy of the documents (a) and (b) from the Client Service Center in the CIPO. For the detail, please access to the CIPO’s website; <http://www.ic.gc.ca/eic/site/cipointernet-internetopic.nsf/eng/wr00827.html>

⁴ When the request is filed based on the U.S. claims shown in the item of “Claim(s) is/are objected to”, it is required to submit translation of “Allowable Subject Matter” of the office action that shows claims are allowable/patentable except objection.

⁵ See Appendix C

(c) Copies of references cited by the OEE examiner⁶

If the references are patent documents, the applicant doesn't have to submit them because the JPO usually possesses them. When the JPO does not possess the patent document, the applicant has to submit the patent document at the examiner's request. Non-patent literature must always be submitted. The translations of the references are unnecessary.

(d) Claim correspondence table

The applicant requesting PPH must submit a claim correspondence table, which indicates how all claims in the JPO application sufficiently correspond to the patentable/allowable claims in the OEE application.

When claims are just literal translation, the applicant can just write down that "they are the same" in the table. When claims are not just literal translation, it is necessary to explain the sufficient correspondence of each claim based on the criteria 1. (c) (Please refer to the Example form).

When the applicant has already submitted above documents (a) to (d) to the JPO through simultaneous or past procedures, the applicant may incorporate the documents by reference and does not have to attach them.

3. Example of "The Explanation of Circumstances Concerning Accelerated Examination" for filing request for an accelerated examination under the PPH pilot program

(1) Circumstances

When an applicant files a request for an accelerated examination under the PPH pilot program to the JPO, an applicant must submit a request form "The Explanation of Circumstances Concerning Accelerated Examination" based on the procedure prescribed in "the Guidelines of the Accelerated Examination and Appeal"⁷.

The applicant must indicate that the application is included in (I) to (IV) of 1. (a), and that the accelerated examination is requested under the PPH pilot program. The application number, publication number, or a patent number of the corresponding OEE application(s) also must be written.

⁶ Where the USPTO is the OEE, all of references cited in "Detailed Action" or "Reason for Allowance" must be submitted.

Where the CIPO is OEE, it is unnecessary to submit translations of the references or to submit the documents which are listed as references of interest defined in the 15.05.02 in the MOPOP.

⁷ <https://www.jpo.go.jp/e/system/patent/shinsa/jp-soki/document/index/guideline.pdf>

*In the case that the application which has one or more claims that are determined to be patentable/allowable is different from the OEE application(s) included in (I) to (IV) of 1. (a) (for example, the divisional application of the basic application), the application number, publication number, or a patent number of the application(s) which has claims determined to be patentable/allowable and the relationship between those applications also must be written.

(2) Documents to be submitted

The applicant must list all required documents mentioned above 2. in an identifiable way, even when applicant omits to submit certain documents.

(3) Notice

Please refer to the example of the form of “The Explanation of Circumstances Concerning Accelerated Examination” for both on-line and paper procedures.

Note that in the case of paper procedure, the pendency period (the period between the request for PPH and the first office action) tends to be longer than on-line procedure.

4. Procedure for the accelerated examination under the PPH pilot program

The JPO decides whether the application can be entitled to the status for an accelerated examination under the PPH when it receives a request with the documents stated above. When the JPO decides that the request is acceptable, the application is assigned a special status for an accelerated examination under the PPH.

In those instances where the request does not meet all the requirements set forth above, the applicant will be notified and the defects in the request will be identified. Before the issue of the notification of not assigning a special status for accelerated examination under the PPH, the applicant will be given opportunity to submit missing documents. Even after the issue of the notification of not assigning a special status for accelerated examination under the PPH, the applicant can request the PPH again.

Part II

PPH using the PCT international work products

Applicants can request accelerated examination by a prescribed procedure including submission of relevant documents on an application which is filed with the JPO and satisfies the following requirements under the Patent Prosecution Highway pilot program based on PCT international work products (PCT-PPH pilot program).

When filing a request for the PCT-PPH pilot program, an applicant must submit a request form “The Explanation of Circumstances Concerning Accelerated Examination” based on the procedure prescribed in “the Guidelines of the Accelerated Examination and Appeal”¹. Under the PCT-PPH pilot program, an applicant is not required to fill in the section “2. the disclosure of prior arts and comparison between the claimed invention and prior art” in “The Explanation of Circumstances Concerning Accelerated Examination”.

1. Requirements

The application which is filed with the JPO and on which the applicant files a request under the PCT-PPH must satisfy the following requirements:

- (1) The latest work product in the international phase of a PCT application corresponding to the application (“international work product”), namely the Written Opinion of International Search Authority (WO/ISA), the Written Opinion of International Preliminary Examination Authority (WO/IPEA) or the International Preliminary Examination Report (IPER), indicates at least one claim as patentable/allowable (from the aspect of novelty, inventive steps and industrial applicability).**

Note that the ISA and the IPEA which produced the WO/ISA, WO/IPEA and the IPER are limited to the one of the authorities listed in Appendix A, but, if priority is claimed, the priority claim can be to an application in any Office, see example A' in Annex II (application ZZ can be any national application).

The applicant cannot file a request under PCT-PPH on the basis of an International Search Report (ISR) only.

In case any observation is described in Box VIII of WO/ISA, WO/IPEA or IPER which forms the basis of a PCT-PPH request, the applicant must explain why the claim(s) is/are not subject to the observation irrespective of whether or not an amendment is submitted to correct the observation noted in Box VIII. The application will not be eligible for participating in PCT-PPH pilot program if the applicant does not explain why the claim(s) is/are not subject to the observation. In this regard, however, it does not affect the decision on the eligibility of the application whether the explanation is adequate and/or whether the amendment submitted

¹ <https://www.jpo.go.jp/e/system/patent/shinsa/jp-soki/document/index/guideline.pdf>

overcomes the observation noted in Box VIII.

- (2) The relationship between the application and the corresponding international application satisfies one of the following requirements:**
- (A) The application is a national phase application of the corresponding international application. (See Figures A, A', and A'' in Annex II)**
 - (B) The application is a national application as a basis of the priority claim of the corresponding international application. (See Figure B in Annex II)**
 - (C) The application is a national phase application of an international application claiming priority from the corresponding international application. (See Figure C in Annex II)**
 - (D) The application is a national application claiming foreign/domestic priority from the corresponding international application. (See Figure D in Annex II)**
 - (E) The application is the derivative application (divisional application and application claiming domestic priority etc.) of the application which satisfies one of the above requirements (A) – (D). (See Figures E1 and E2 in Annex II)**
- (3) All claims on file, as originally filed or as amended, for examination under the PCT-PPH must sufficiently correspond to one or more of those claims indicated to be patentable/allowable in the latest international work product of the corresponding international application.**

Claims are considered to "sufficiently correspond" where, accounting for differences due to translations and claim format, the claims of the application are of the same or similar scope as the claims indicated to be patentable/allowable in the latest international work product, or the claims of the application are narrower in scope than the claims indicated to be patentable/allowable in the latest international work product.

In this regard, a claim that is narrower in scope occurs when a claim indicated to be patentable/allowable in the latest international work product is amended to be further limited by an additional feature that is supported in the specification (description and/or claims) of the application.

A claim of the application which introduces a new/different category of claims to those claims indicated to be patentable/allowable in the latest international work product is not considered to sufficiently correspond. For example, the claims indicated to be patentable/allowable in the latest international work product only contain claims to a process of manufacturing a product, then the claims of the application are not considered to sufficiently correspond if the claims of the application introduce product claims that are dependent on the corresponding process claims.

Any claims amended or added after the grant of the request for participation in the PCT-PPH

pilot program need not to sufficiently correspond to the claims indicated as patentable/allowable in the latest international work product.

- (4) The JPO has not begun examination of the application at the time of request under PCT-PPH.**
- (5) A “Request for Substantive Examination” must have been filed at the JPO either at the time of the PCT-PPH request or previously.**

2. Documents to be submitted

Documents (1) to (4) below must be submitted by attaching to “The Explanation of Circumstances Concerning Accelerated Examination”.

Note that even when it is not needed to submit documents below, the name of the documents must be listed in “The Explanation of Circumstances Concerning Accelerated Examination” (Please refer to the Example form for the detail).

- (1) A copy of the latest international work product which indicated the claims to be patentable/allowable and their Japanese or English translations if they are not in English.**

In case the application satisfies the relationship 1.(2)(A), the applicant need not submit a copy of the International Preliminary Report on Patentability (IPRP) and any English translations thereof because a copy of these documents is already contained in the file-wrapper of the application. In addition, if the copy of the latest international work product and the copy of the translation are available via “PATENTSCOPE (registered trademark)”², an applicant need not submit these documents, unless otherwise requested by the JPO.

(WO/ISA and IPER are usually available as “IPRP Chapter I” and “IPRP Chapter II” respectively in 30 months after the priority date.)

Machine translation will be admissible, but if it is impossible for the examiner to understand the outline of the latest translated international work product due to insufficient translation, the examiner can request the applicant to resubmit translations.

- (2) A copy of a set of claims which the latest international work product of the corresponding international application indicated to be patentable/allowable and their Japanese or English translations if they are not in English**

If the copy of the set of claims which are indicated to be patentable/allowable is available via “PATENTSCOPE (registered trademark)” (e.g. the international Patent Gazette has been published), an applicant need not submit this document unless otherwise requested by the JPO.

Machine translations will be admissible, but if it is impossible for the examiner to understand

² <http://www.wipo.int/pctdb/en/index.jsp>

the outline of the translated claims due to insufficient translation, the examiner can request the applicant to resubmit translations.

(3) A copy of references cited in the latest international work product of the international application corresponding to the application.

Documents which are only referred to as references and consequently do not consist of the reasons for refusal do not have to be submitted.

If the reference is a patent document, the applicant is not required to submit it. In case the JPO has difficulty in obtaining the document, however, the applicant may be asked to submit it. Non-patent literature must always be submitted. Translations of cited references are unnecessary.

(4) A claims correspondence table which indicates how all claims in the application sufficiently correspond to the claims indicated to be patentable/allowable.

When claims are just literal translation, the applicant can just write down that “they are the same” in the table. When claims are not just literal translation, it is necessary to explain the sufficient correspondence of each claim based on the criteria 1. (3) (Please refer to the Example form).

When an applicant has already submitted the above mentioned documents (1) - (4) to the JPO through simultaneous or past procedures, the applicant may incorporate the documents by reference and is thus not required to attach the documents.

3. Example of “The Explanation of Circumstances Concerning Accelerated Examination” for filing request for an accelerated examination under the PCT-PPH pilot program

(1) Circumstances

The applicant must indicate that the application is included in (A) to (E) of 1. (2), and that the accelerated examination is requested under the PCT-PPH pilot program. The application number(s) of the corresponding international application(s) also must be written.

In case any observation is described in Box VIII of WO/ISA, WO/IPEA or IPER which forms the basis of a PCT-PPH request, the applicant must explain why the claim(s) is/are not subject to the observation.

(2) Documents to be submitted

The applicant must list all required documents mentioned above 2. in an identifiable way, even when applicant omits to submit certain documents.

(3) Notice

Please refer to the example of the form of “The Explanation of Circumstances Concerning Accelerated Examination” for both on-line and paper procedures³.

Note that in the case of paper procedure, the pendency period (the period between the request for PPH and the first office action) tends to be longer than on-line procedure.

4. Procedure for the accelerated examination under the PPH pilot program

The JPO decides whether the application can be entitled to the status for an accelerated examination under the PCT-PPH when it receives a request with the documents stated above. When the JPO decides that the request is acceptable, the application is assigned a special status for an accelerated examination under the PCT-PPH.

In those instances where the request does not meet all the requirements set forth above, the applicant will be notified and the defects in the request will be identified. Before the issue of the notification of not assigning a special status for accelerated examination under the PCT-PPH, the applicant will be given opportunity to submit missing documents. Even after the issue of the notification of not assigning a special status for accelerated examination under the PCT-PPH, the applicant can request the PCT-PPH again.

³ <https://www.jpo.go.jp/e/system/patent/shinsa/jp-soki/document/index/guideline.pdf>

A A case meeting requirement (a) (I)
- Paris route -

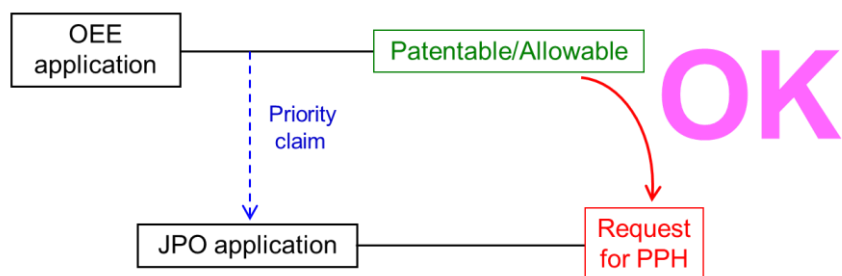

B A case meeting requirement (a) (I)
- PCT route -

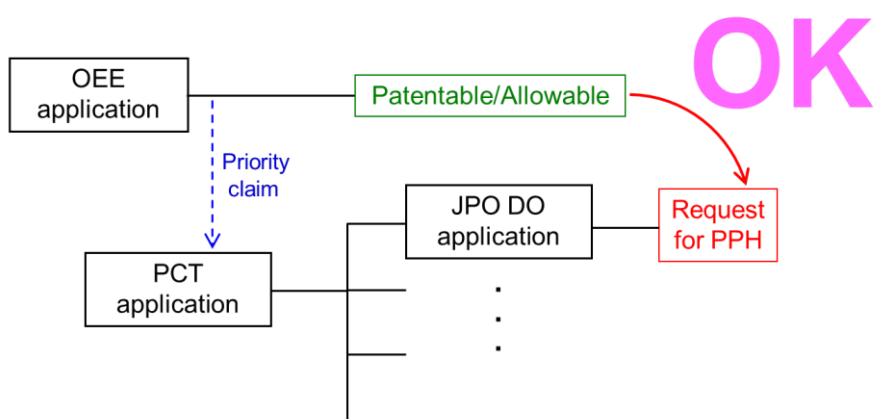

C A case meeting requirement (a) (I)
- PCT route, Domestic priority -

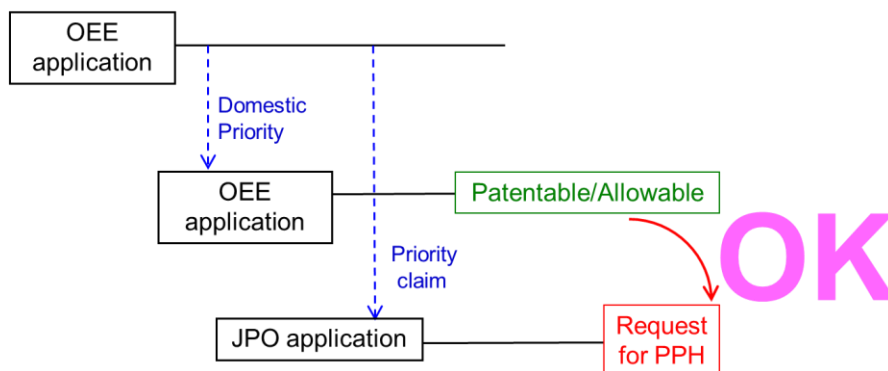

D A case meeting requirement (a) (II)
- Paris route -

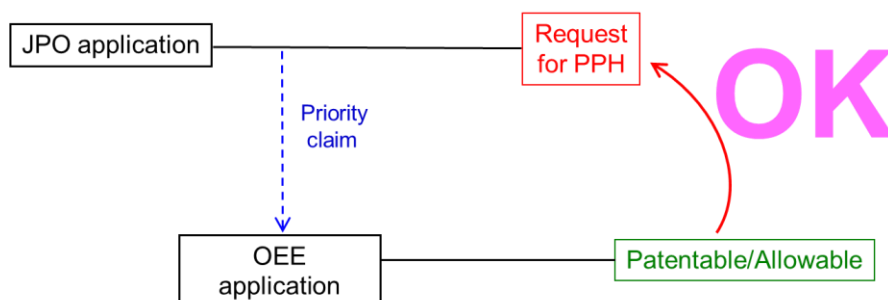

E A case meeting requirement (a) (II)
- PCT route -

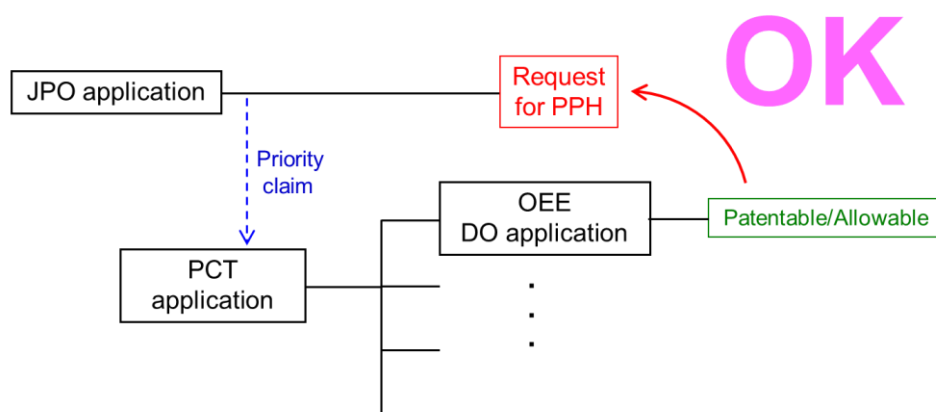

F A case meeting requirement (a) (III)
- Paris route, but the first application is from the third country -

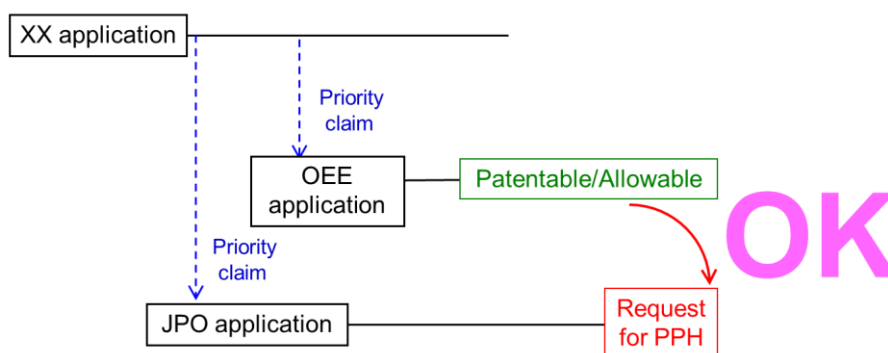

XX : the office other than the OEE

G

A case meeting requirement (a) (III)

- PCT route, but the first application is from the third country -

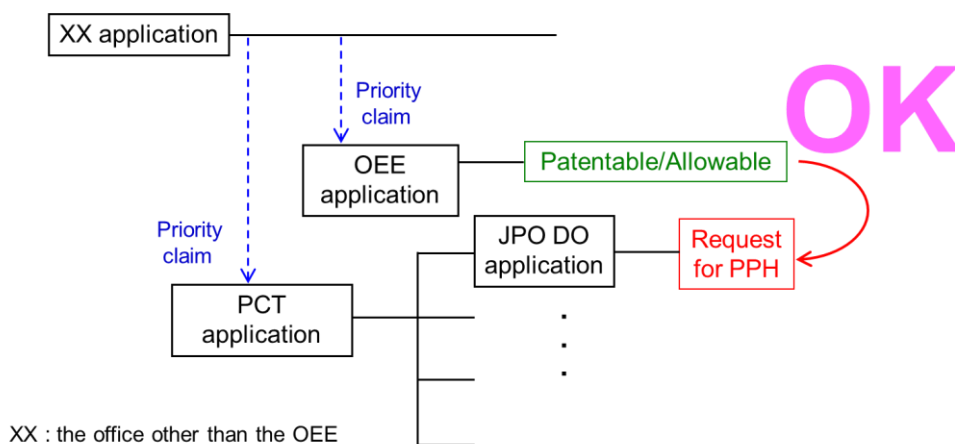

H

A case meeting requirement (a) (I)

- Paris route & Complex priority -

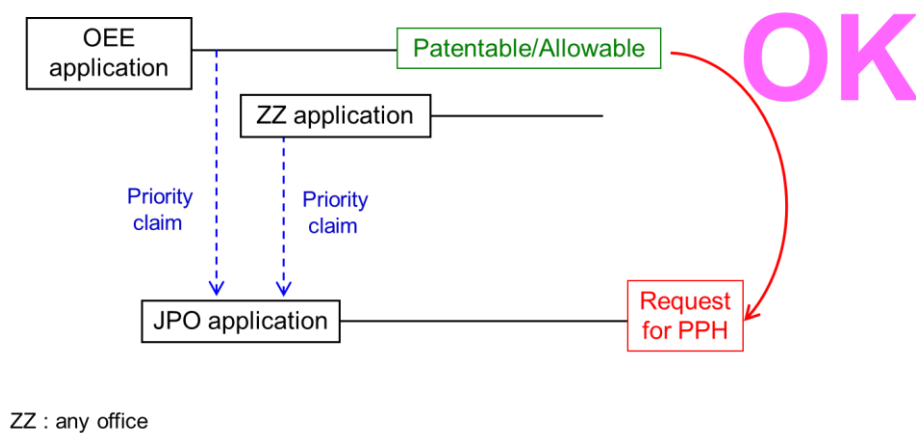

I A case meeting requirement (a) (I)
- Paris route & divisional application -

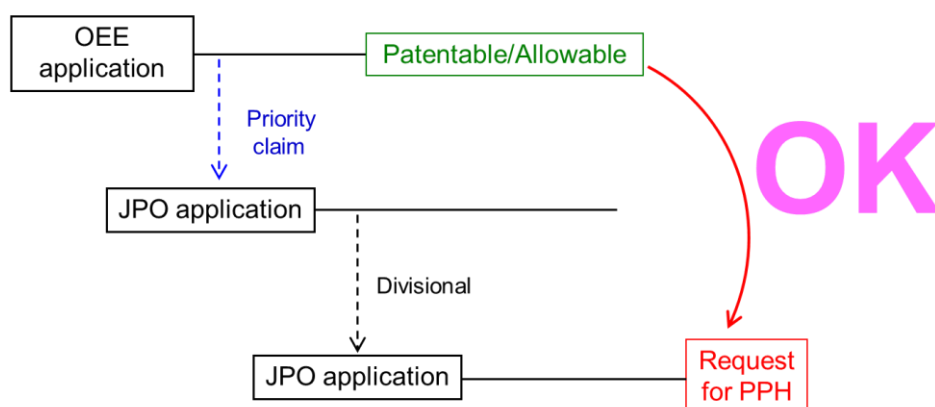

J A case meeting requirement (a) (I)
- PCT route -

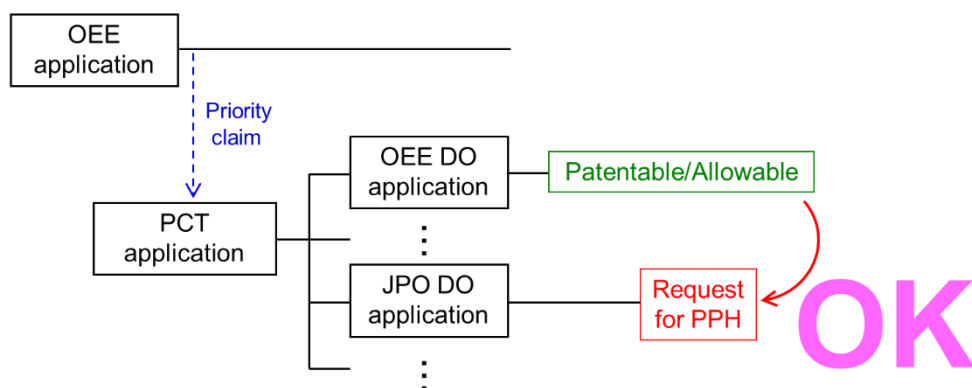

K A case meeting requirement (a) (IV)
- Direct PCT route -

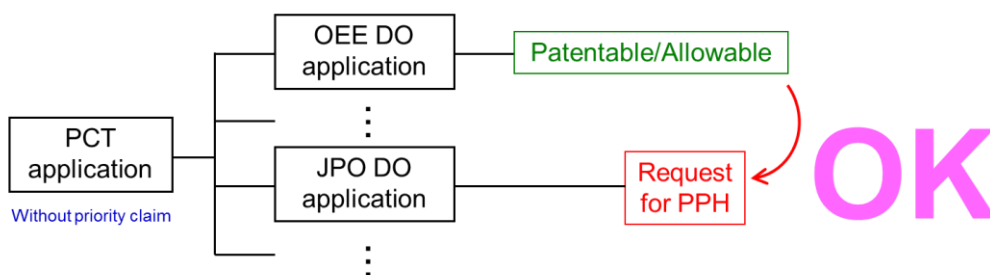

L A case meeting requirement (a) (III)
- Direct PCT & Paris route -

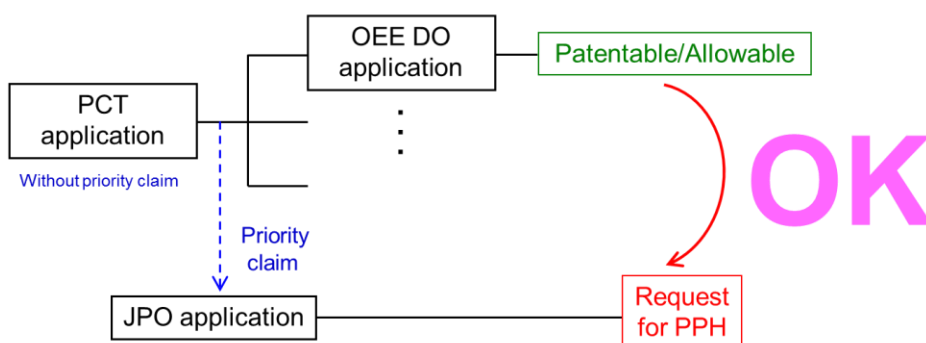

M A case meeting requirement (a) (III)
- Direct PCT & PCT route -

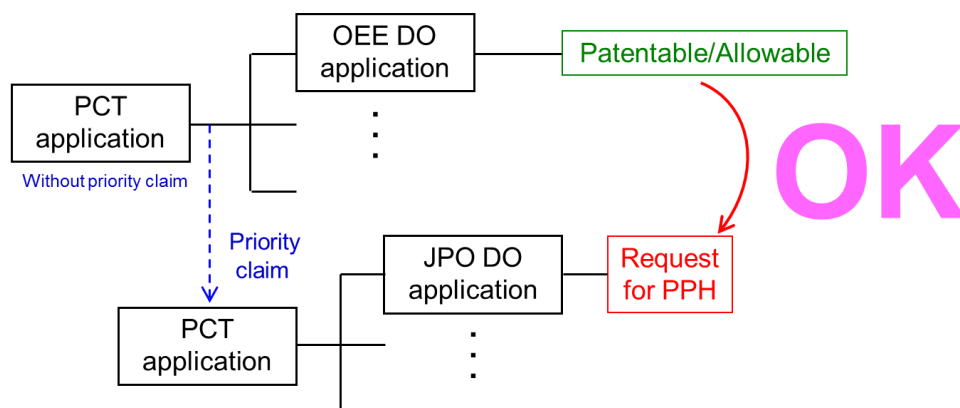

N A case meeting requirement (a) (III)
- Direct PCT & PCT route -

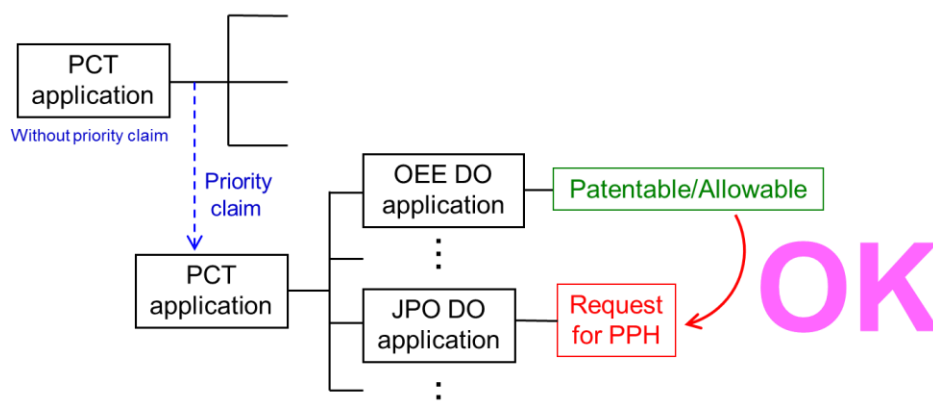

O A case not meeting requirement (d)
- Examination has begun before a request for PPH -

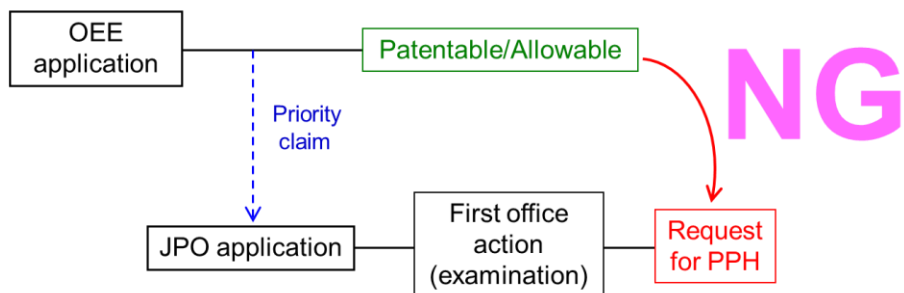

(A) The application is a national phase application of the corresponding international application.

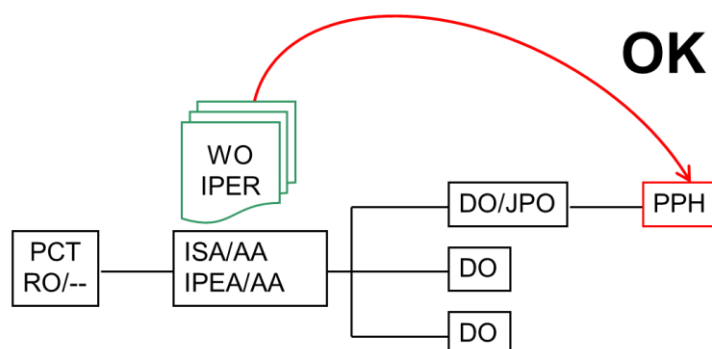

AA=One of the authorities listed in Appendix A

(A') The application is a national phase application of the corresponding international application.
(The corresponding international application claims priority from a national application.)

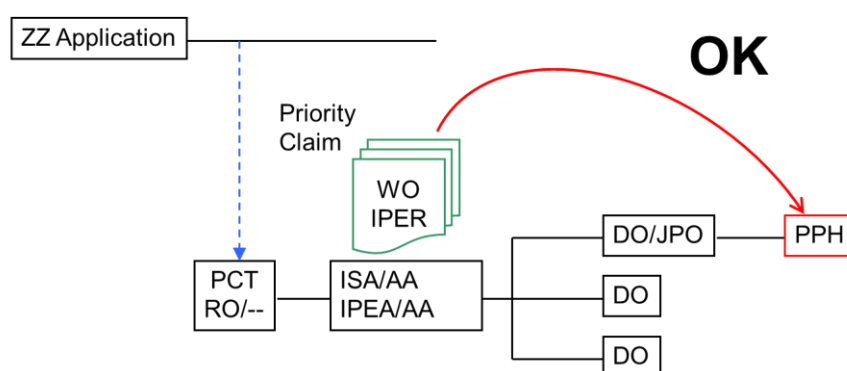

AA=One of the authorities listed in Appendix A

ZZ=any office

(A'') The application is a national phase application of the corresponding international application.
 (The corresponding international application claims priority from an international application.)

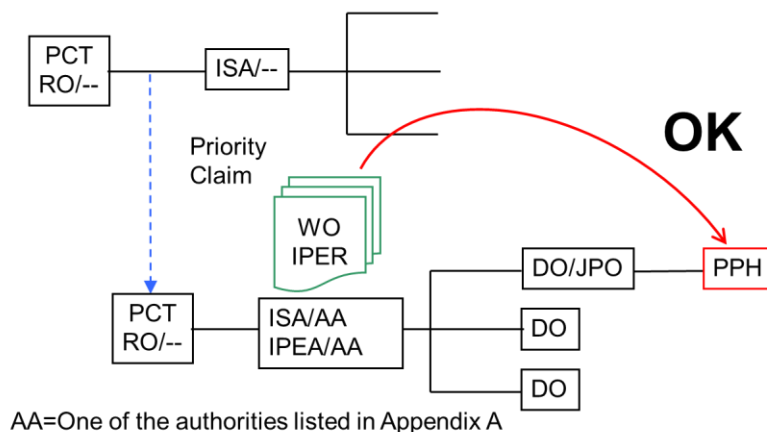

(B) The application is a national application as a basis of the priority claim of the corresponding international application.

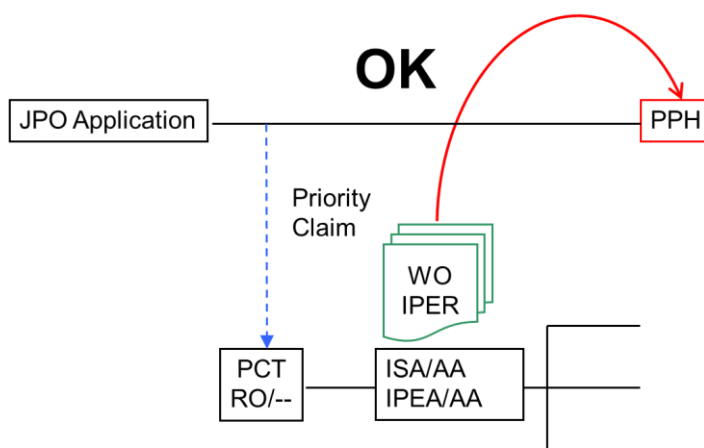

(C) The application is a national phase application of an international application claiming priority from the corresponding international application.

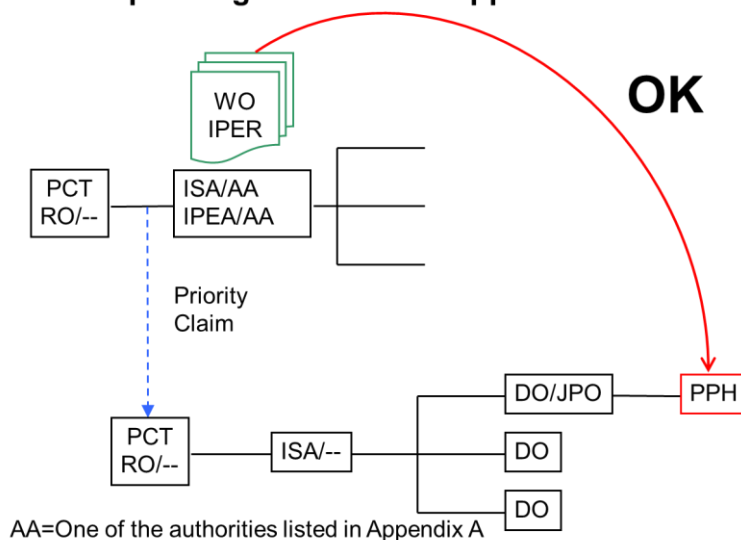

(D) The application is a national application claiming foreign/domestic priority from the corresponding international application.

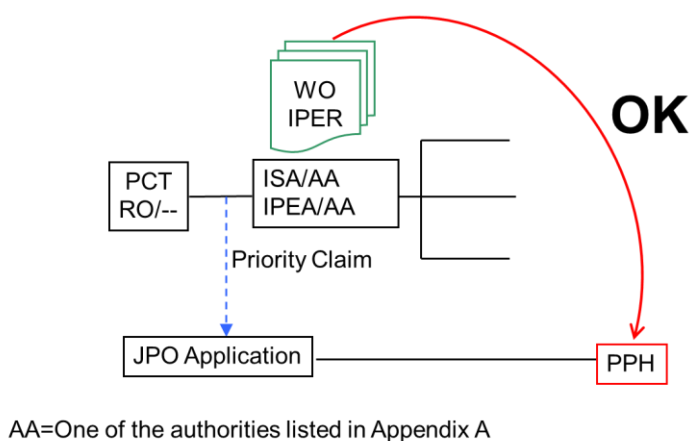

(E1) The application is a divisional application of an application which satisfies the requirement (A).

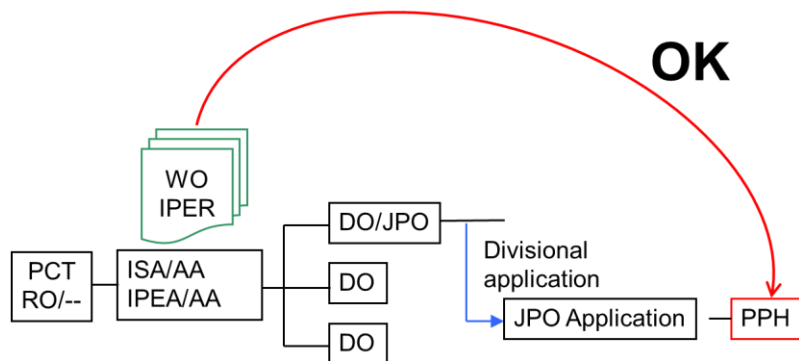

AA=One of the authorities listed in Appendix A

(E2) The application is an application claiming domestic priority from an application which satisfies the requirement (B).

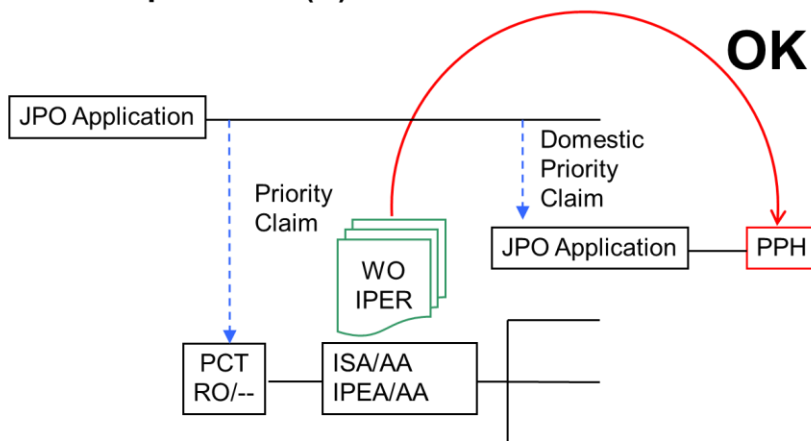

AA=One of the authorities listed in Appendix A