

Procedures to file a request to the DIP (Department of Intellectual Property in Thailand) for Patent Prosecution Highway Pilot Program between the DIP and the JPO (Japan Patent Office)

Applicants can request accelerated examination by a prescribed procedure including submission of relevant documents on an application which is filed with the DIP and satisfies the following requirements under the DIP-JPO Patent Prosecution Highway (PPH) pilot program based on the JPO application.

When filing a request for the PPH pilot program, an applicant must submit a request form to the DIP.

The offices may terminate the PPH pilot program if the volume of participation exceeds manageable level, or for any other reason. Ex Ante notice will be published if the PPH pilot program is terminated.

The PPH pilot program will be in effect for two (2) years commencing on January 1, 2020 and will end on December 31, 2021. However, the program may be extended after a joint DIP-JPO review and assessment of the program implementation.

1. Requirements

- (a) *The DIP application (including a PCT national phase application) is***
- (i) *an application which validly claims priority under the Paris Convention to the JPO application(s) (examples are provided in ANNEX I, Figure A, B, C, F, G and H), or***
 - (ii) *a PCT national phase application without priority claim (examples are provided in ANNEX I, Figure I), or***
 - (iii) *an application which validly claims priority under the Paris Convention to the PCT application(s) without priority claim (examples are provided in ANNEX I, Figure J, K and L).***

The DIP application, which validly claims priority to multiple JPO or direct PCT applications, or which is the divisional application validly based on the originally filed application that is included in (i) to (iii) above, is also eligible.

- (b) *At least one corresponding application exists in the JPO and has one or more claims that are determined to be patentable/allowable by the JPO.***

The corresponding application(s) can be the application which forms the basis of the priority claim, an application which derived from the JPO application which forms the basis of the priority claim (e.g., a divisional application of the JPO application or an application which claims domestic priority to the JPO application (see Figure C in Annex I)), or an JPO national phase application of a PCT application (see Figures H, I, J, K and L in Annex I).

Claims are “determined to be allowable/patentable” when the JPO examiner clearly identified the claims to be allowable/patentable in the latest office action, even if the application is not granted for patent yet.

The office action includes one of the following:

- (a) Decision to Grant a Patent
- (b) Notification of Reasons for Refusal
- (c) Decision of Refusal
- (d) Appeal Decision

For example, if the following routine expression is described in the “Notification of Reason for Refusal” of the JPO, those claims are clearly identified to be allowable/patentable.

“<Claims which has been found no reason for refusal>

At present for invention concerning Claim___, no reason for refusal is found.”

- (c) All claims on file, as originally filed or as amended, for examination under the PPH must sufficiently correspond to one or more of those claims indicated as allowable in the JPO.**

Claims are considered to “sufficiently correspond” where, accounting for differences due to translations and claim format, the claims in the DIP are of the same or similar scope as the claims in the JPO, or the claims in the DIP are narrower in scope than the claims in the JPO. In this regard, a claim that is narrower in scope occurs when a JPO claim is amended to be further limited by an additional feature that is supported in the specification (description and/or claims).

A claim in the DIP which introduces a new/different category of claims to those claims indicated as allowable in the JPO is not considered to sufficiently correspond. For example, where the JPO claims only contain claims to a process of manufacturing a product, then the claims in the DIP are not considered to sufficiently correspond if the DIP claims introduce product claims that are dependent on the corresponding process claims.

Any claims amended or added after the grant of the request for participation in the PPH pilot program need not to sufficiently correspond to the claims indicated as allowable in the JPO application.

- (d) The DIP has not begun examination of the application at the time of request for the PPH (an example is provided in ANNEX, figure M).**
- (e) A “Request for Substantive Examination” must have been filed at the DIP either at the time of the PPH request or previously.**

2. Documents to be submitted

Documents (a) to (d) below must be submitted by attaching to the PPH request.

- (a) Copies of all office actions (which are relevant to substantial examination for patentability in the JPO) which were issued for the corresponding application by the JPO, and translations of them¹.**

Either Thai or English is acceptable as translation language. The applicant does not have to submit a copy of JPO office actions and translations of them when those documents are provided via JPO's dossier access system because the office actions and their machine translations are available for the DIP examiner via the JPO's dossier access system. If they cannot be obtained by the DIP examiner via the JPO's dossier access system, the applicant may be notified and requested to provide the necessary documents.

- (b) Copies of all claims determined to be patentable/allowable by the JPO, and translations of them.**

Either Thai or English is acceptable as translation language. The applicant does not have to submit a copy of claims indicated to be allowable/patentable in the JPO, and translations thereof when the documents are provided via JPO's dossier access system because they are available for the DIP examiner via the JPO's dossier access system. If they cannot be obtained by the DIP examiner via the JPO's dossier access system, the applicant may be notified and requested to provide the necessary documents.

- (c) Copies of references cited by the JPO examiner**

If the references are patent documents, the applicant doesn't have to submit them because the DIP usually possesses them. When the DIP does not possess the patent document, the applicant has to submit the patent document at the examiner's request. Non-patent literature must always be submitted.

The translations of the references are unnecessary.

- (d) Claim correspondence table**

The applicant requesting PPH must submit a claim correspondence table, which indicates how all claims in the DIP application sufficiently correspond to the patentable/allowable claims in the JPO application.

When claims are just literal translation, the applicant can just write down that "they are the same" in the table. When claims are not just literal translation, it is necessary to explain the sufficient correspondence of each claim.

¹ Machine translations will be admissible, but if it is impossible for the examiner to understand the outline of the translated office action or claims due to insufficient translation, the examiner can request the applicant to resubmit translations.

PPH using the national work products from the JPO

When the applicant has already submitted above documents (a) to (d) to the DIP through simultaneous or past procedures, the applicant may incorporate the documents by reference and does not have to attach them.

3. DIP – JPO PPH request form

Subject: Request for an accelerated examination under the PPH pilot program

Date of filing: _____

Thai Application number: _____

Title of the invention: _____

Applicant: _____

Corresponding JPO Application number: _____

Priority Application number _____

Documents submitted:

- Copies of all office actions (which are relevant to substantial examination for patentability in the JPO) which were issued for the corresponding application by the JPO and
- translations of them
- Copies of all claims determined to be patentable/allowable by the JPO and
- translations of them
- Copies of references cited by the JPO examiner
- Claim correspondence table

Claim correspondence table		
The claim in the DIP	The patentable claim in the JPO	Comments about the correspondence

(Documents to be omitted to submit)

A A case meeting requirement (a) (i)
- Paris route -

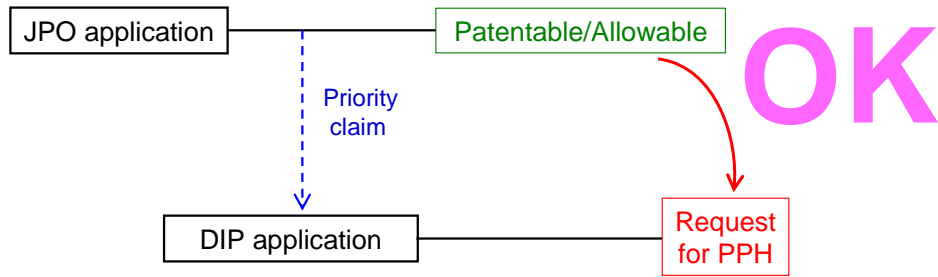

B A case meeting requirement (a) (i)
- PCT route -

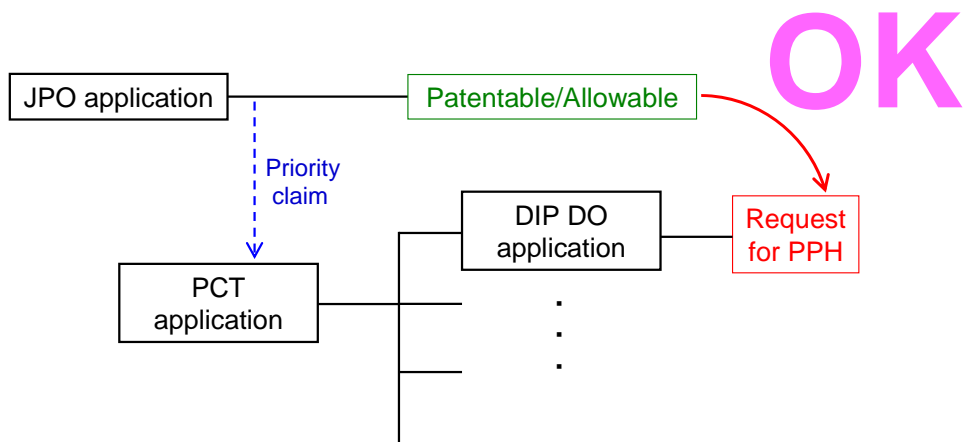

C

A case meeting requirement (a) (i)

- Paris route, Domestic priority -

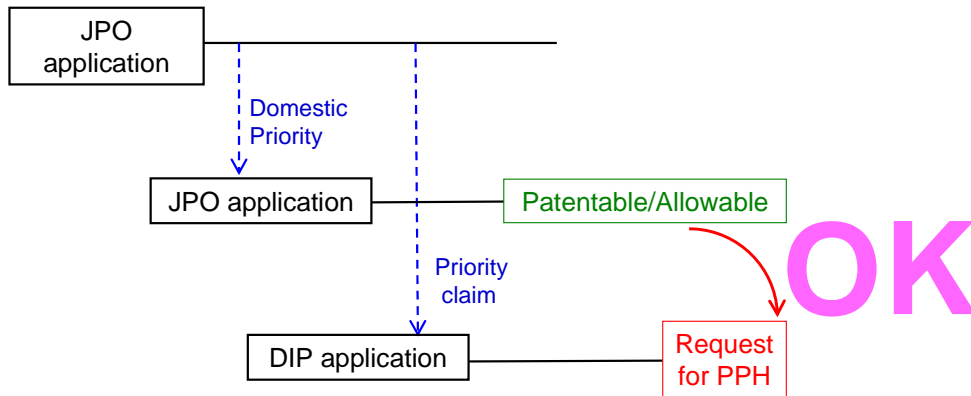

D

A case not meeting requirement (a)

- Paris route, but the first application is from the third country -

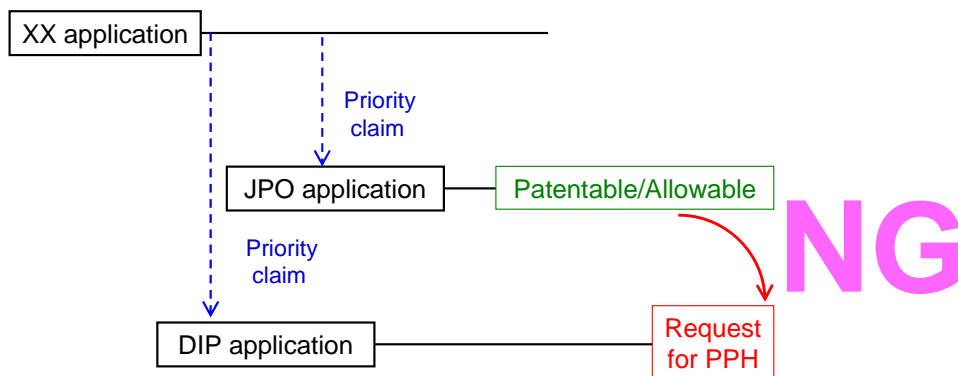

XX : the office other than the JPO

E A case not meeting requirement (a)
 - PCT route, but the first application is from the third country -

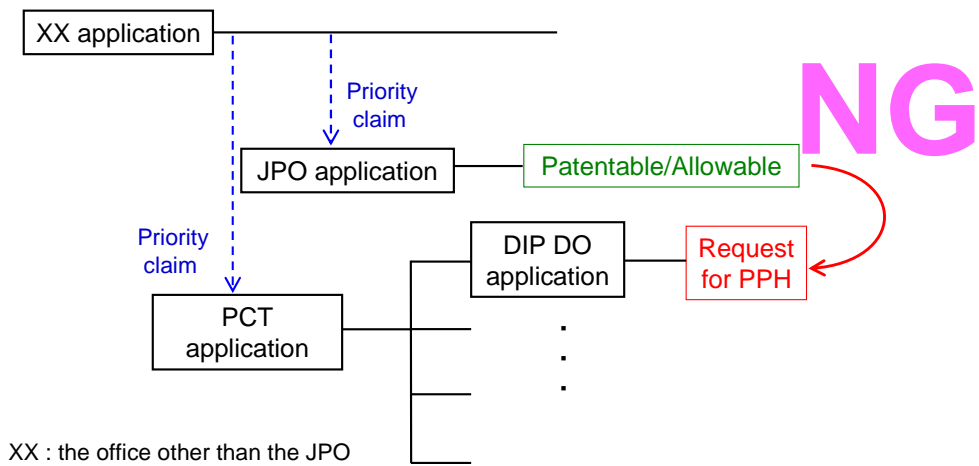

F A case meeting requirement (a) (i)
 - Paris route & Complex priority -

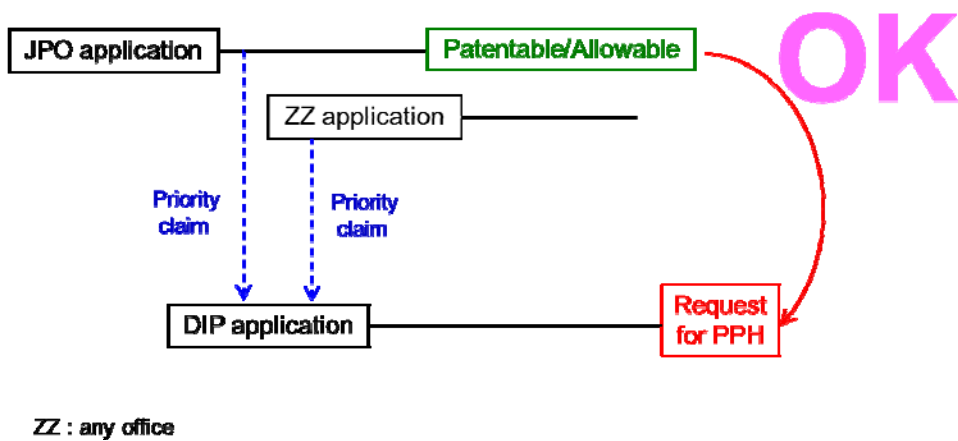

G

A case meeting requirement (a) (i)
- Paris route & divisional application -

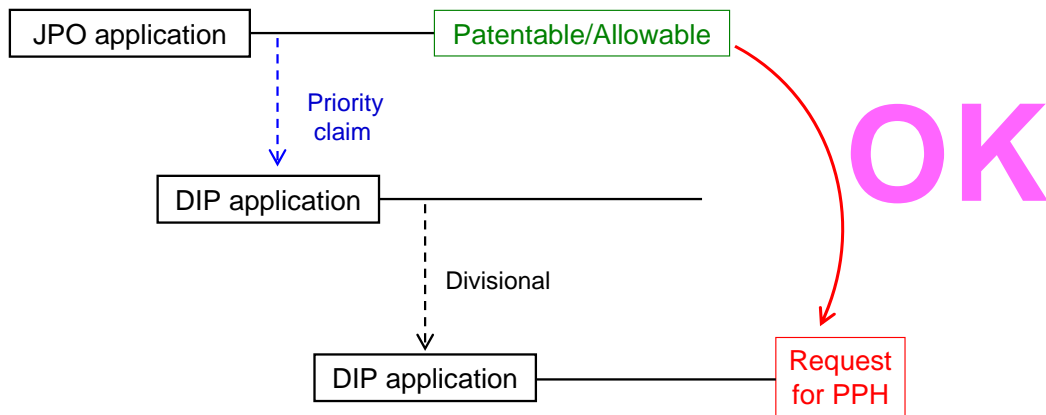

H

A case meeting requirement (a) (i)
- PCT route -

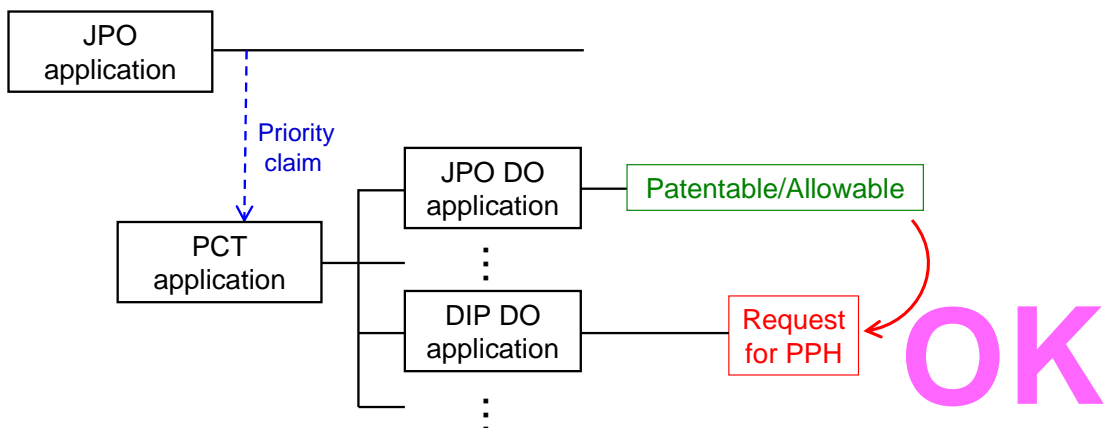

I A case meeting requirement (a) (ii)
- Direct PCT route -

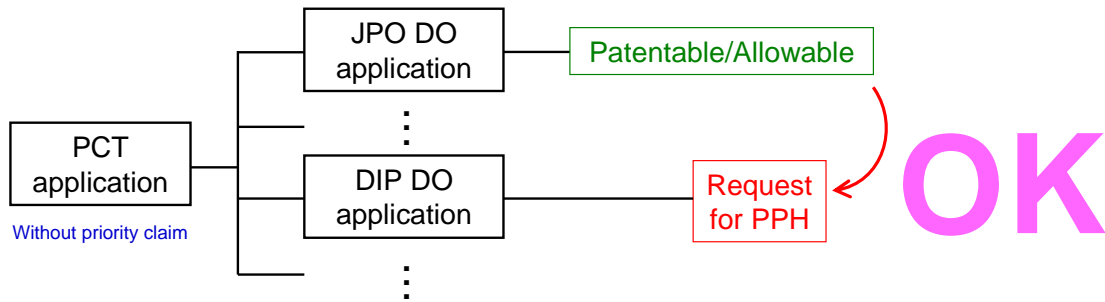

J A case meeting requirement (a) (iii)
- Direct PCT & Paris route -

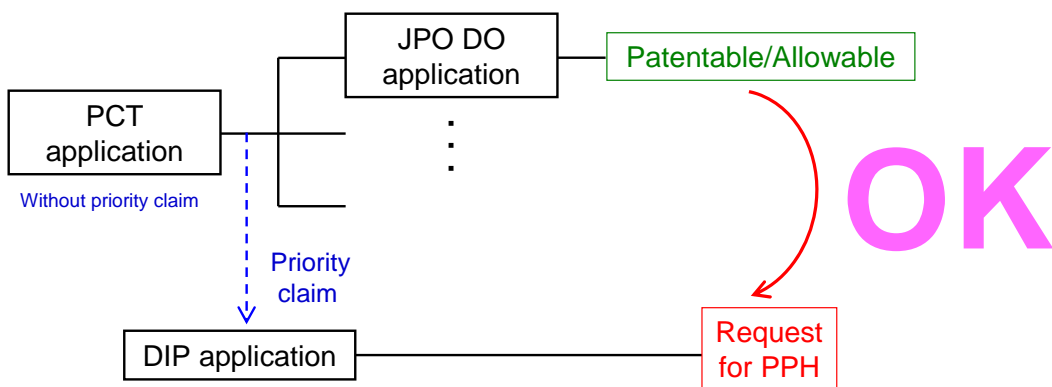

K A case meeting requirement (a) (iii)
 - Direct PCT & PCT route -

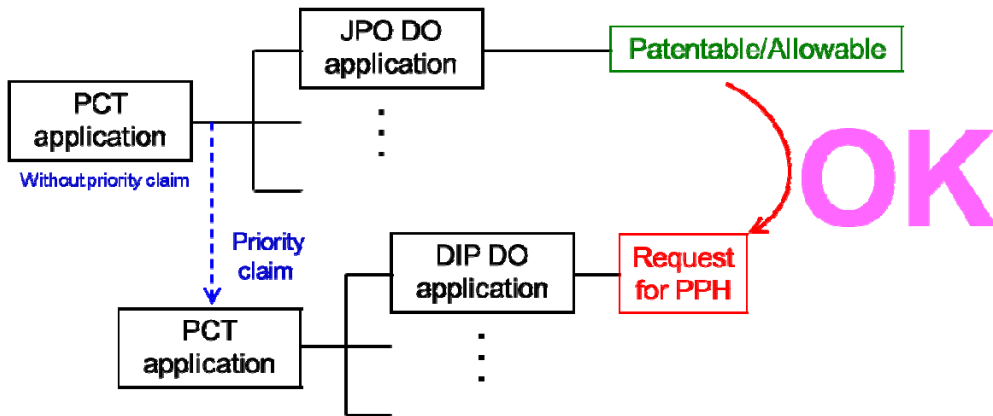

L A case meeting requirement (a) (iii)
 - Direct PCT & PCT route -

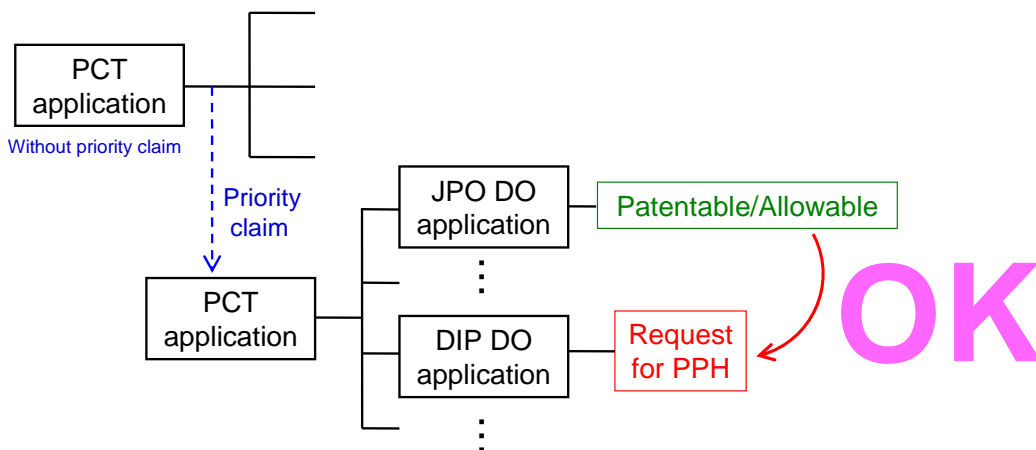

M A case not meeting requirement (d)
- Examination has begun before a request for PPH -

