

## **Procedures to file a request to the JPO (Japan Patent Office) for Patent Prosecution Highway Pilot Program between the JPO and the DIP (Department of Intellectual Property)**

The Patent Prosecution Highway (PPH) pilot program between the Japan Patent Office (JPO) and the Department of Intellectual Property (DIP) will be in effect for two (2) years commencing on January 1, 2022 and will end on December 31, 2023. The pilot program may be extended after a joint JPO-DIP review and assessment of the program implementation.

The offices may suspend or terminate the PPH pilot program if the volume of participation exceeds manageable level, or for any other reason. Ex ante notice will be published if the PPH pilot program is suspend or terminated.

Applicants can request accelerated examination in accordance with a prescribed procedure including submission of relevant documents on an application which is filed with the JPO and satisfies the following requirements under the JPO-DIP PPH pilot program based on the DIP application.

When filing a request for the PPH pilot program, an applicant must submit a request form “The Explanation of Circumstances Concerning Accelerated Examination” based on the procedure prescribed in “the Guidelines of the Accelerated Examination and Appeal.”<sup>1</sup> Under the PPH pilot program, an applicant is not required to fill in the section “2. the disclosure of prior arts and comparison between the claimed invention and prior art” in “The Explanation of Circumstances Concerning Accelerated Examination”.

### **1. Requirements**

***(a) The JPO application (including a PCT national phase application) is***

- (i) an application which validly claims priority under the Paris Convention to the DIP application(s) (examples are provided in ANNEX, figure A, B, C, F, G and H), or***
- (ii) a PCT national phase application without priority claim (examples are provided in ANNEX, figure I), or***
- (iii) an application which validly claims priority under the Paris Convention to the PCT application(s) without priority claim (examples are provided in ANNEX, figure J, K and L).***

The JPO application, which validly claims priority to multiple DIP or direct PCT applications, or which is the divisional application validly based on the originally filed

---

<sup>1</sup> <https://www.jpo.go.jp/e/system/patent/shinsa/jp-soki/document/index/guideline.pdf> (in Japanese)

application that is included in (i) to (iii) above, is also eligible.

The pilot program is not applicable on the basis of DIP 'petty patent' applications.

***(b) At least one corresponding application exists in the DIP and has one or more claims that are determined to be patentable/allowable by the DIP.***

The corresponding application can be the application which forms the basis of the priority claim, an application which derived from the DIP application which forms the basis of the priority claim (e.g. a divisional application of the DIP application), or an DIP national phase application of a PCT application.

Claims are "determined to be allowable/patentable" when the DIP examiner clearly identifies the claims to be allowable/patentable in the latest office action, even if the application is not granted for patent yet. The office action includes one of the following:

- (i) Examination Report
- (ii) Search Report
- (iii) Rejection Report
- (iv) Appeal Decision

***(c) All claims on file, as originally filed or as amended, for examination under the PPH must sufficiently correspond to one or more of those claims indicated as allowable in the DIP.***

Claims are considered to "sufficiently correspond" where, accounting for differences due to translations and claim format, the claims in the JPO are of the same or similar scope as the claims in the DIP, or the claims in the JPO are narrower in scope than the claims in the DIP.

In this regard, a claim that is narrower in scope occurs when an DIP claim is amended to be further limited by an additional feature that is supported in the specification (description and/or claims).

A claim in the JPO which introduces a new/different category of claims to those claims indicated as allowable in the DIP is not considered to sufficiently correspond. For example, where the DIP claims only contain claims to a process of manufacturing a product, then the claims in the JPO are not considered to sufficiently correspond if the JPO claims introduce product claims that are dependent on the corresponding process claims.

Any claims amended or added after the grant of the request for participation in the PPH pilot program need not to sufficiently correspond to the claims indicated as allowable in the DIP application.

***(d) The JPO has not begun examination of the application at the time of request for the PPH (an example is provided in ANNEX, figure M).***

***(e) A “Request for Substantive Examination” must have been filed at the JPO either at the time of the PPH request or previously.***

## **2. Documents to be submitted**

Documents (a) to (d) below must be submitted by attaching to “The Explanation of Circumstances Concerning Accelerated Examination”.

Note that even when it is not needed to submit documents below, the name of the documents must be listed in “The Explanation of Circumstances Concerning Accelerated Examination” (Please refer to the Example form for the detail).

***(a) Copies of all office actions (which are relevant to substantial examination for patentability in the DIP), which were sent for the corresponding application by the DIP, and translations of them<sup>2</sup>.***

Either Japanese or English is acceptable as translation language.

***(b) Copies of all claims determined to be patentable/allowable by the DIP, and translations of them<sup>2</sup>.***

Either Japanese or English is acceptable as translation language.

***(c) Copies of references cited by the DIP examiner***

If the references are patent documents, the applicant doesn't have to submit them because the JPO usually possesses them. When the JPO does not possess the patent document, the applicant has to submit the patent document at the examiner's request. Non-patent literature must always be submitted.

The translations of the references are unnecessary.

***(d) Claim correspondence table***

The applicant requesting PPH must submit a claim correspondence table, which indicates how all claims in the JPO application sufficiently correspond to the patentable/allowable claims in the DIP application.

When claims are just literal translation, the applicant can just write down that “they are the same” in the table. When claims are not just literal translation, it is necessary to explain the sufficient correspondence of each claim based on the criteria 1. (c) (Please refer to the Example form).

When the applicant has already submitted above documents (a) to (d) to the JPO through

---

<sup>2</sup> Machine translations will be admissible, but if it is impossible for the examiner to understand the outline of the translated office action or claims due to insufficient translation, the examiner can request the applicant to resubmit translations.

simultaneous or past procedures, the applicant may incorporate the documents by reference and does not have to attach them.

### **3. Example of “The Explanation of Circumstances Concerning Accelerated Examination” for filing request an accelerated examination under the PPH pilot program**

#### **(1) Circumstances**

When an applicant files a request for an accelerated examination under the PPH pilot program to the JPO, an applicant must submit a request form “The Explanation of Circumstances Concerning Accelerated Examination” based on the procedure prescribed in “the Guidelines of the Accelerated Examination and Appeal”<sup>3</sup>.

The applicant must indicate that the application is included in (i) to (iii) of 1. (a), and that the accelerated examination is requested under the PPH pilot program. The application number, publication number, or a patent number of the corresponding DIP application(s) also must be written.

\*In the case that the application which has one or more claims that are determined to be patentable/allowable is different from the DIP application(s) included in (i) to (iii) of 1. (a) (for example, the divisional application of the basic application), the application number, publication number, or a patent number of the application(s) which has claims determined to be patentable/allowable and the relationship between those applications also must be written.

#### **(2) Documents to be submitted**

The applicant must list all required documents mentioned above 2. in an identifiable way, even when applicant omits to submit certain documents.

#### **(3) Notice**

Forms of “The Explanation of Circumstances Concerning Accelerated Examination” are different between on-line procedure and paper procedure. Please refer to the examples of forms when filling in (“Form 1 for Accelerated Examination” for on-line procedures, and “Form 2 for Accelerated Examination” for paper procedures.).

---

<sup>3</sup> <https://www.jpo.go.jp/e/system/patent/shinsa/jp-soki/document/index/guideline.pdf> (in Japanese)

### Example form of on-line procedures

(Example of the request based on the claims indicated patentable/allowable in the written opinion of the report on the state of the art)

<p>【書類名】 早期審査に関する事情説明書                  The name of this paper</p>	
<p>【提出日】 令和00年00月00日                  Date of filing</p>	
<p>【あて先】 特許庁長官殿                  Destination</p>	
<p>【事件の表示】                  【出願番号】 特願 0000-000000                  Application number</p>	
<p>【提出者】                  【識別番号】 000000000                  【住所又は居所】 〇〇県〇〇市〇丁目                  【氏名又は名称】 〇〇〇〇〇                  The name and address of who submit this</p>	
<p>【代理人】                  【識別番号】 000000000                  【住所又は居所】 〇〇県〇〇市〇丁目                  【氏名又は名称】 〇〇 〇〇                  The name and address of the attorney</p>	
<p>【早期審査の種別】 特許審査ハイウェイ                  Kind of accelerated examination</p>	
<p>【早期審査に関する事情説明】                  The explanation of circumstances concerning accelerated examination</p>	
<p>1. 事情                  特許審査ハイウェイに基づく早期審査の申請を行う。                  本出願はタイ商務省知的財産局への出願(特許出願番号0000000000)をパリ条約に基づく優先権の基礎出願とする出願である。当該タイ出願に対しては、タイ商務省知的財産局により特許査定が発行されている。</p>	
<p>1. Circumstances                  The accelerated examination is requested under the PPH program.                  This application is an application validly claiming the priority under the Paris Convention to the corresponding DIP application (the application number is 0000000000), and the Decision to Grant a Patent has been issued by the DIP.</p>	

以下において、「引用非特許文献1」とは、「J. W. Mellor, “A Comprehensive Treatise on Inorganic and Theoretical Chemistry”, Vol. III, U.S., Longmans Green and Co.,1931, p. 341.」である。

In what follows, “non-patent literature1” is “J. W. Mellor, “A Comprehensive Treatise on Inorganic and Theoretical Chemistry”, Vol. III, U.S., Longmans Green and Co.,1931, p. 341.”

If the name of the document is long (over than 50 letters), it is impossible to write it down directly to the column “【物件名】.” Please write down the full name of the document in the column “【早期審査に関する事情説明】” and name it properly. Then write the name in the column “【物件名】.”

【提出物件の目録】

The list of submitted documents

List up the documents to be submitted

- 【物件名】 PPH 申請書 1
- 【物件名】 \*\*年\*\*月\*\*日付の拒絶理由通知書の写し及びその翻訳文 1
- 【物件名】 \*\*年\*\*月\*\*日付の特許査定書の写し及びその翻訳文 1
- 【物件名】 特許可能と判断された請求項の写し及びその翻訳文 1
- 【物件名】 引用非特許文献1 1

- (The name of the document) PPH request form 1
- (The name of the document) Copy and translation of Notification of Reasons for Refusal in the DIP on (date) 1
- (The name of the document) Copy and translation of grant in the DIP on (date) 1
- (The name of the document) Copy and translation of the claims indicated patentable in the report on the state of the art and written opinion in the DIP on (date) 1
- (The name of the document) Cited non patent literature1 1

Use the same name as “【物件名】” under “【提出物件の目録】.”

【添付物件】

The list of attached documents

- 【物件名】 PPH 申請書
- PPH request form

【内容】

Attach the document here as image file or text.

<b>PPH申請書</b> <b>(REQUEST FOR PARTICIPATION IN THE PATENT PROSECUTION HIGHWAY (PPH) (PILOT) PROGRAM)</b>							
<b>A. 書誌事項(Bibliographic Data)</b>							
出願番号 (Application Number)	<input style="width: 90%;" type="text" value="特願0000-000000"/> <small>出願番号が付与されていない場合には、国際出願番号を記載</small>						
<b>B. 必要事項 (Request)</b>							
<b>出願人による以下に基づく特許審査ハイウェイの申請：</b> <b>(Applicant requests participation in the Patent Prosecution Highway (PPH) (pilot) program based on:)</b>							
先行庁 (Office of Earlier Examination (OEE))	<input style="width: 90%;" type="text" value="タイ商務省知的財産局(DIP)"/>						
先行庁の審査書類形式 (OEE Work Products Type)	<input checked="" type="checkbox"/> 国内出願の審査結果を利用 ( P P H 又は P P H M O T T A I N A I ) (National/Regional Office Action(s)) <input type="checkbox"/> P C T 国際段階成果物を利用 ( P C T - P P H ) (WO-ISA, WO-IPEA or IPER)						
先行庁の対応出願番号 (国際出願番号含む) (OEE Application Number (Incl. PCT Application Number))	<table style="width: 100%; border-collapse: collapse;"> <tr> <td style="width: 10%; text-align: center;">+</td> <td style="width: 10%; text-align: center;">-</td> <td style="width: 80%;"><input style="width: 95%;" type="text" value="TH 0000000000"/></td> </tr> <tr> <td style="text-align: center;">+</td> <td style="text-align: center;">-</td> <td><input style="width: 95%;" type="text"/></td> </tr> </table>	+	-	<input style="width: 95%;" type="text" value="TH 0000000000"/>	+	-	<input style="width: 95%;" type="text"/>
+	-	<input style="width: 95%;" type="text" value="TH 0000000000"/>					
+	-	<input style="width: 95%;" type="text"/>					
<b>C. 必要書類 (Required Documents)</b>							
<b>I. 先行庁のオフィスアクションの写し、及び、その翻訳文 (OEE Work Products and, if required, Translations)</b>							
1. <input checked="" type="checkbox"/> 先行庁のオフィスアクションの写しを添付する (A copy of OEE work products is attached; or) <input type="checkbox"/> ドシエ・アクセス・システム又はPATENTSCOPEにおいて、オフィスアクションの情報が提供されている (The office is requested to retrieve documents via the Dossier Access System or PATENTSCOPE)							
2. <input checked="" type="checkbox"/> 上記 1. の日本語又は英語の翻訳文を添付する (A translation of documents in 1 in a language accepted by the Office is attached; or) <input type="checkbox"/> ドシエ・アクセス・システム又はPATENTSCOPEにおいて、上記 1. の英語翻訳が提供されている (The office is requested to retrieve documents via the Dossier Access System or PATENTSCOPE)							
<b>II. 先行庁における特許可能な請求項、及び、その翻訳文 (Patentable/Allowable Claims Determined by OEE and, if required, Translations)</b>							
3. <input checked="" type="checkbox"/> 先行庁出願において特許可能と判断された全請求項の写しを添付する (A copy of all claims determined to be patentable/allowable by OEE is attached; or) <input type="checkbox"/> ドシエ・アクセス・システム又はPATENTSCOPEにおいて、特許可能と判断された全請求項の情報が提供されている (The office is requested to retrieve documents via the Dossier Access System or PATENTSCOPE)							
4. <input checked="" type="checkbox"/> 上記 3. の日本語又は英語の翻訳文を添付する (A translation of documents in 3 in a language accepted by the Office is attached; or) <input type="checkbox"/> ドシエ・アクセス・システム又はPATENTSCOPEにおいて、上記 3. の英語翻訳が提供されている (The office is requested to retrieve documents via the Dossier Access System or PATENTSCOPE)							
<b>III. 引用文献 (Documents Cited in OEE Work Products (if required))</b>							
5. <input checked="" type="checkbox"/> 引用非特許文献を添付する (A copy of all documents cited in OEE work products is attached (excluding patent documents); or) <input type="checkbox"/> 引用非特許文献も引用特許文献もなし (No references cited)							

<b>IV. 先の提出書類の援用の表示 (Previously submitted documents)</b>	
6. <input type="checkbox"/> 上記において「添付する」とチェックした書類のうち、先に提出した書類を援用する (If any of the above mentioned documents have been submitted before, please specify:)	
+ -	(先行庁のオフィスアクションの写し、及び、その翻訳文)
+ -	
+ -	(先行庁における特許可能な請求項、及び、その翻訳文)
+ -	
+ -	(引用非特許文献)
+ -	
<b>V. 提出物件 (援用する物件は除く) (List of names of documents submitted)</b> 早期審査に関する事情説明書に記載のとおり。	
<b>VI. 提出を省略する物件 (List of names of documents omitted for submission)</b>	
+ -	(先行庁のオフィスアクションの写し、及び、その翻訳文)
+ -	
+ -	(先行庁における特許可能な請求項、及び、その翻訳文)
+ -	
+ -	(引用特許文献)
+ -	米国特許第00000000号明細書
+ -	独国特許出願公開第000000000000号明細書
+ -	



<b>D. 請求項の対応関係 (Claims Correspondence)</b>			
<p>■ 先行庁の特許可能な全請求項と完全に一致する          (請求項の削除、追加、並び替えが無く、請求項の文言が完全に一致する)          (All the claims in the application sufficiently correspond to the patentable/allowable claims in the OEE application;          or)</p>			
<p><input type="checkbox"/> 請求項の対応関係は、以下の表に記載 (Claims correspondence is explained in the following table)</p>			
+	-	本出願の請求項 (Application Claims)	先行庁の対応請求項 (Corresponding OEE claims)
		対応関係に関するコメント (複数の出願と対応する場合は、コメント欄に対応する出願番号も記載して下さい。) (Explanation regarding the correspondence)	
+	-		
<b>E. 見解書、予備審査報告の第VIII欄 (国際出願に対する意見) に対する釈明 (explaining any Box VIII observations of WO/ISA, WO/IPEA or IPER)</b>			
出願人又は代理人 (Name(s) of applicant(s) or representative(s)) 早期審査に関する事情説明書に記載のとおり。			
提出日 (Date) 早期審査に関する事情説明書に記載のとおり。			
提出者 (Signature(e) of the applicant/representative) 早期審査に関する事情説明書に記載のとおり。			
<p><b>【物件名】 **年**月**日付の拒絶理由通知書及びその翻訳文</b></p> <p style="border: 1px dashed black; padding: 5px; text-align: center;">Copy and translation of Notification of Reasons for Refusal in the DIP on (date)</p> <p><b>【内容】</b> Attach the copy of the document.</p> <div style="border: 1px solid orange; padding: 5px; display: inline-block; margin-left: 200px;">Use the same name as “【物件名】” under “【提出物件の目録】”</div>			
<p><b>【物件名】 **年**月**日付の特許査定およびその翻訳文</b></p> <p style="border: 1px dashed black; padding: 5px; text-align: center;">Copy and translation of grant in the DIP on (date)</p> <p><b>【内容】</b> Attach the copy of the document.</p>			
<p><b>【物件名】 特許可能と判断された請求項の写し及びその翻訳文</b></p> <p style="border: 1px dashed black; padding: 5px; text-align: center;">Copy and translation of the claims indicated patentable in the report on the state of the art and written opinion in the DIP on (date)</p> <p><b>【内容】</b> Attach the copy of the document.</p>			

【物件名】 引用非特許文献1

Cited non-patent literature1

【内容】 Attach the copy of the document.

Note that in the case of paper procedure, the pendency period (the period between the request for PPH and the first office action) tends to be longer than on-line procedure.

**A** A case meeting requirement (a) (i)  
- Paris route -

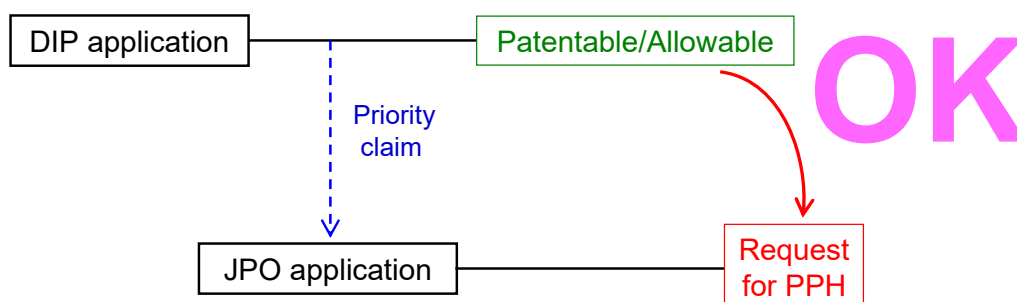

**B** A case meeting requirement (a) (i)  
- PCT route -

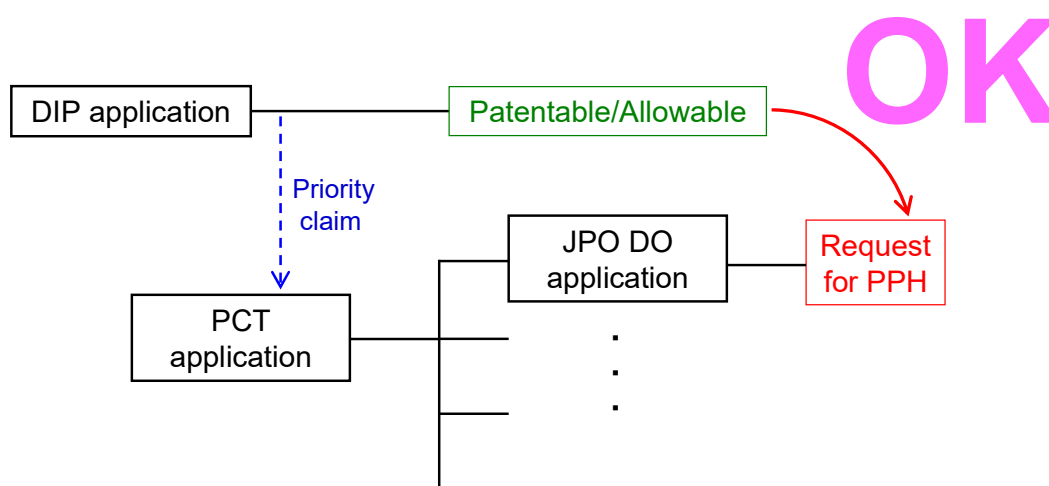

C

## A case meeting requirement (a) (i)

- Paris route, Domestic priority -

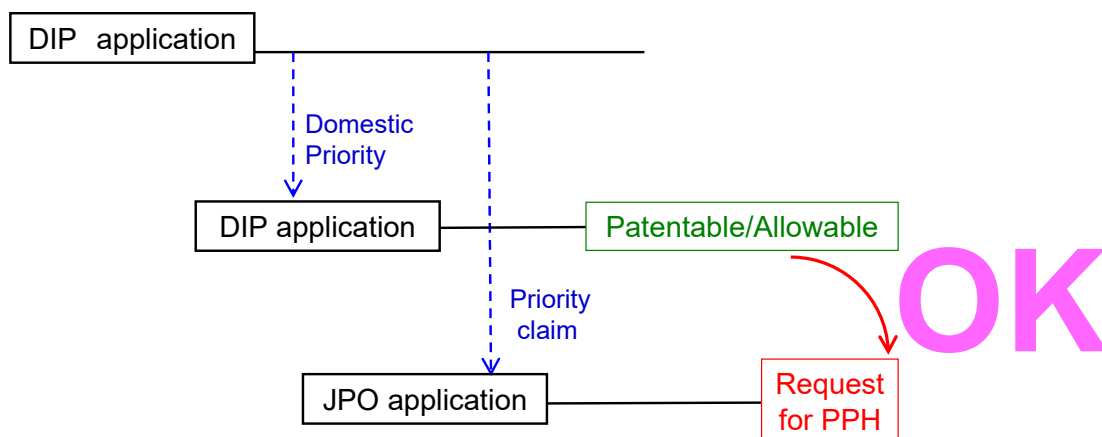

D

## A case not meeting requirement (a)

- Paris route, but the first application is from the third country -

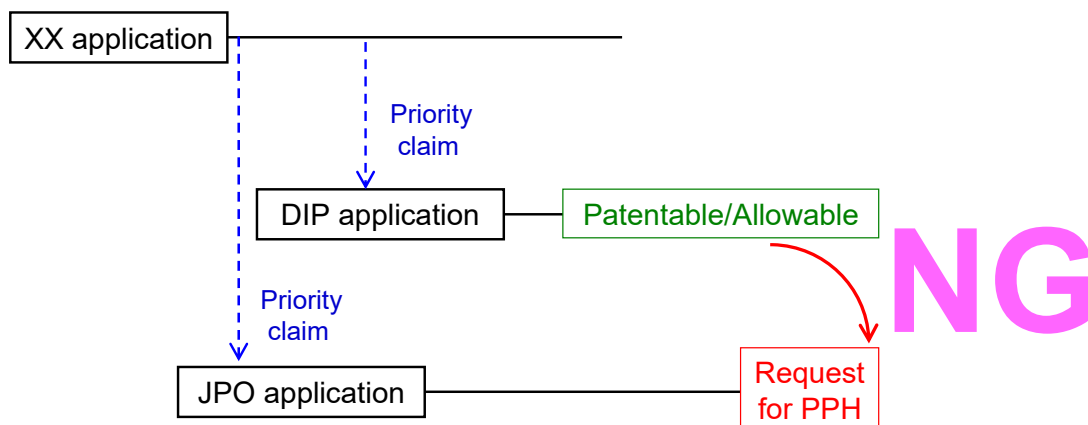

XX : the office other than the DIP

## E A case not meeting requirement (a)

- PCT route, but the first application is from the third country -

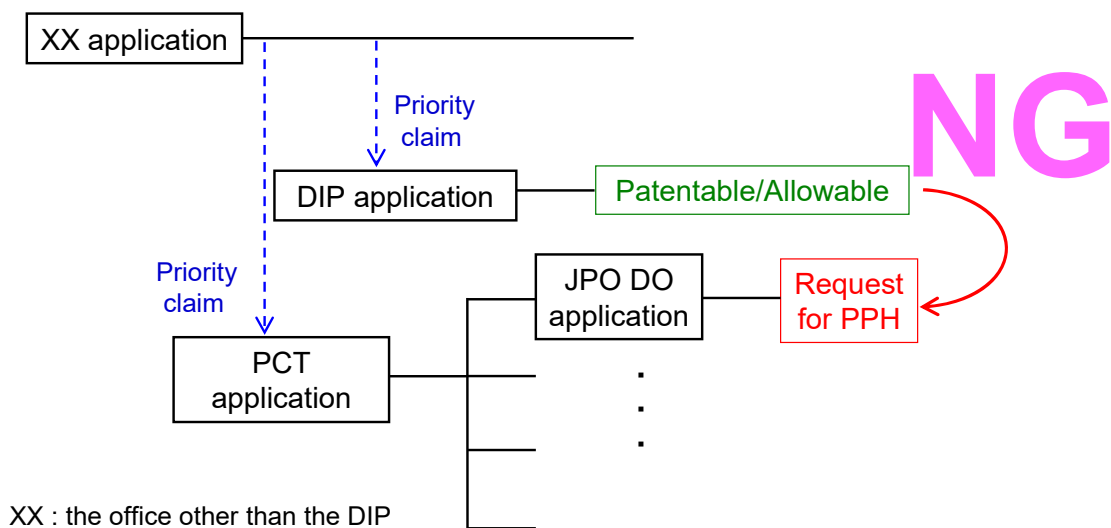

## F A case meeting requirement (a) (i)

- Paris route & Complex priority -

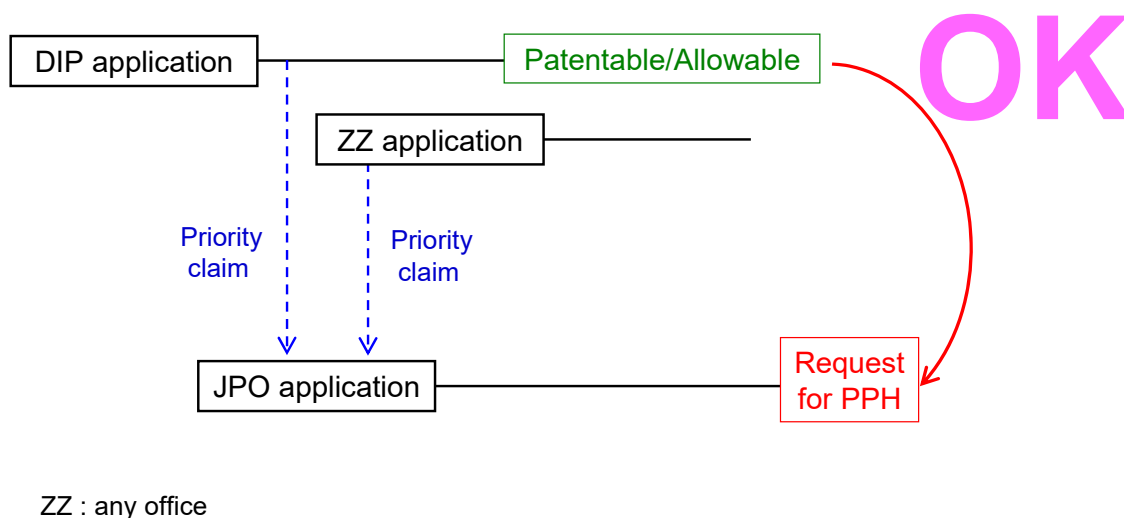

**G** A case meeting requirement (a) (i)  
- Paris route & divisional application -

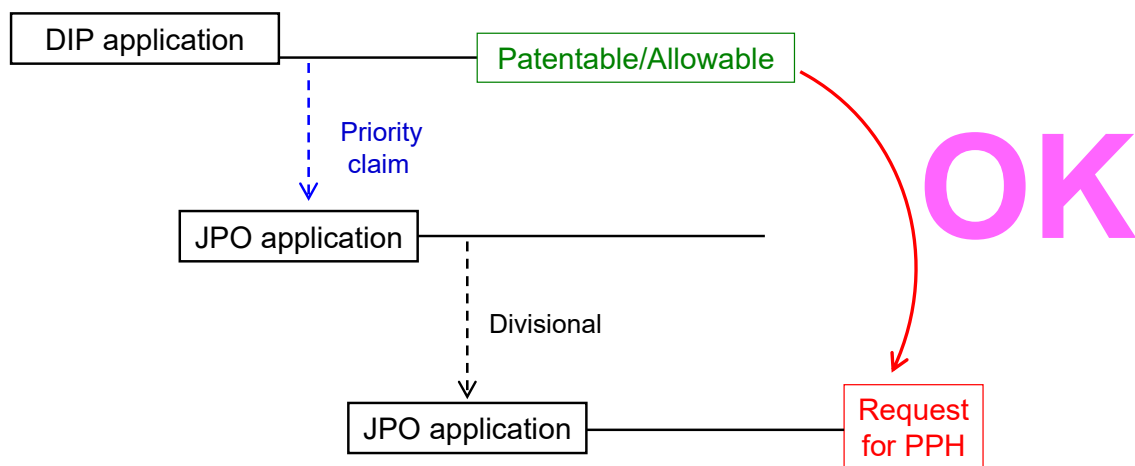

**H** A case meeting requirement (a) (i)  
- PCT route -

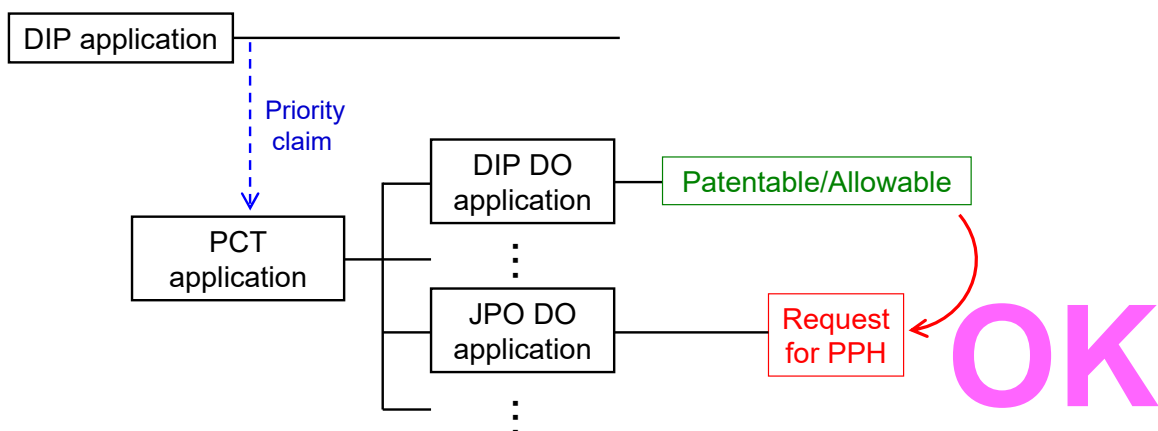

**I** A case meeting requirement (a) (ii)  
- Direct PCT route -

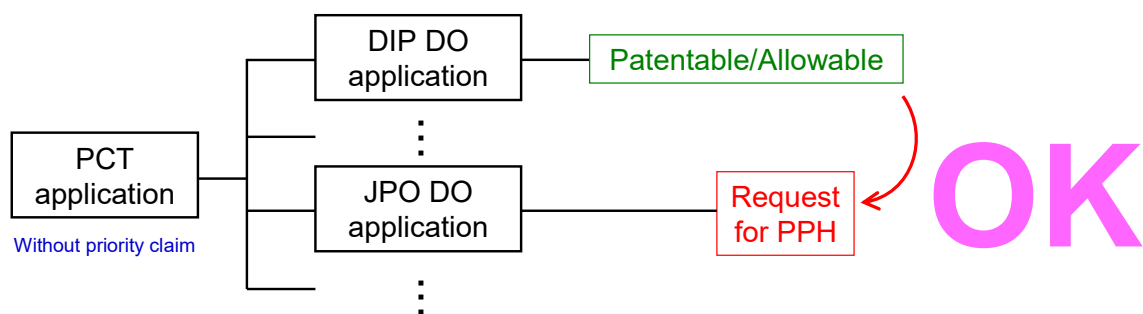

**J** A case meeting requirement (a) (iii)  
- Direct PCT & Paris route -

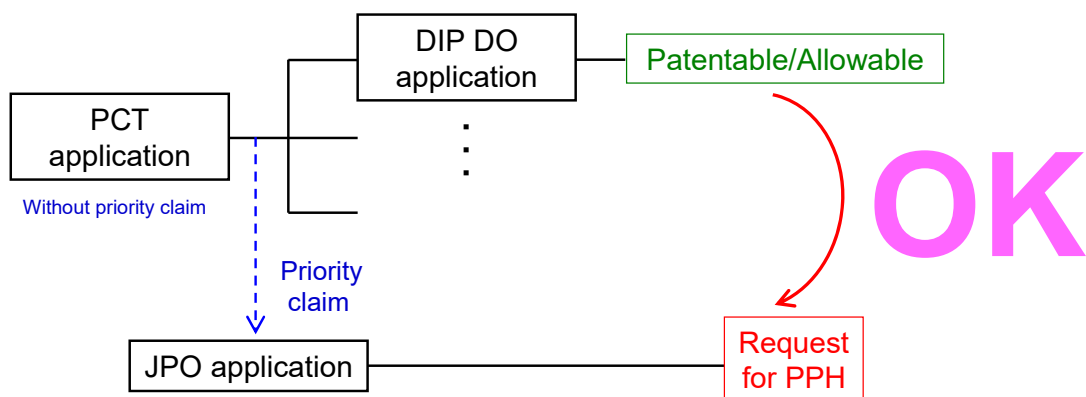

**K** A case meeting requirement (a) (iii)  
- Direct PCT & PCT route -

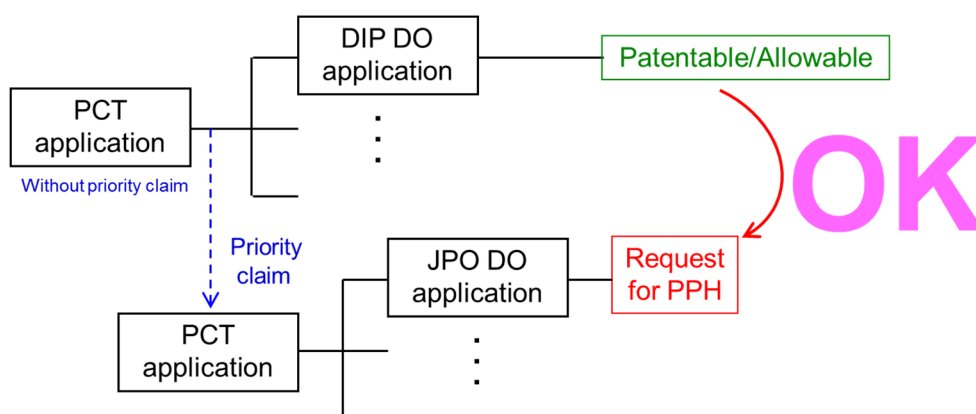

**L** A case meeting requirement (a) (iii)  
- Direct PCT & PCT route -

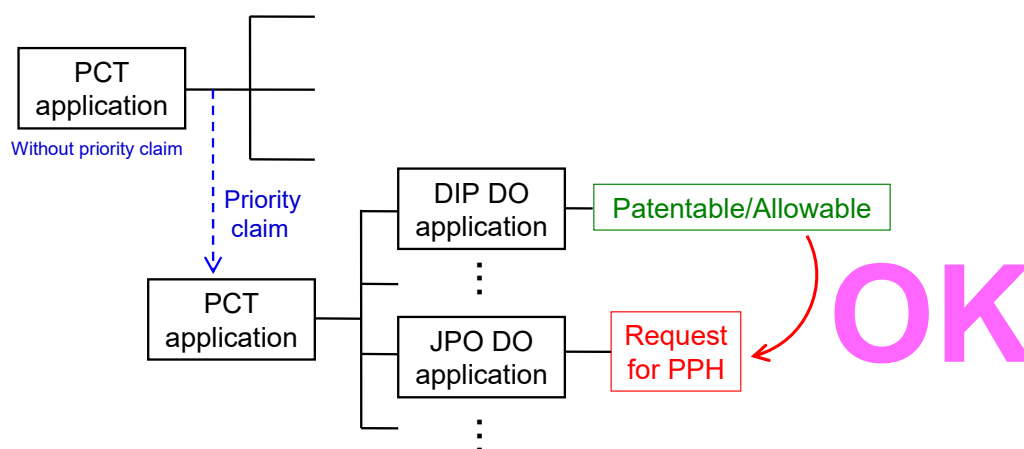



**M** A case not meeting requirement (d)  
- Examination has begun before a request for PPH -

