

GUIDELINE

Procedures to file a request to the TURKPATENT (Turkish Patent and Trademark Office) for Patent Prosecution Highway Pilot Program

Applicants can request accelerated examination by a prescribed procedure including submission of relevant documents on an application which is filed with the TURKPATENT and satisfies the following requirements under the JPO (Japan Patent Office) TURKPATENT Patent Prosecution Highway (PPH) pilot program based on the JPO application (Part I) or PCT international work products (Part II).

When filing a request for the PPH pilot program, an applicant must submit a PPH request form presented in “TURKPATENT PPH request form” of this guideline.

The PPH pilot program between TURKPATENT and JPO will commence on April 1st, 2018 and will end with mutual consent. The offices may terminate the PPH pilot program early if the volume of participation exceeds manageable level, or for any other reason. Ex Ante notice will be published if the PPH pilot program is terminated.

Part I

PPH using the national work products from the JPO

1. Requirements

- (a) ***Both the TURKPATENT application on which PPH is requested and the JPO application(s) forming the basis of the PPH request shall have the same earliest date (whether this be a priority date or a filing date).***

For example, the TURKPATENT application (including PCT national phase application) may be either:

(Case I) an application which validly claims priority under the Paris Convention from the JPO application(s) (examples are provided in ANNEX I, Figures A, B, C, H, I and J), or

(Case II) an application which provides the basis of a valid priority claim under the Paris Convention for the JPO application(s) (including PCT national phase application(s)) (examples are provided in ANNEX I, Figures D and E), or

(Case III) an application which shares a common priority document with the JPO application(s) (including PCT national phase application(s)) (examples are provided in ANNEX I, Figures F, G, L, M and N), or

(Case IV) a PCT national phase application where both the TURKPATENT application and the JPO application(s) are derived from a common PCT international application having no priority claim (an example is provided in ANNEX I, Figure K).

- (b) ***At least one corresponding application exists in the JPO and has one or more claims that are determined to be patentable/allowable by the JPO.***

The corresponding application(s) can be the application which forms the basis of the priority claim, an application which derived from the JPO application which forms the basis of the priority claim (e.g., a divisional application of the JPO application or an application which claims domestic priority to the JPO application (see Figure C in Annex I)), or an JPO national phase application of a PCT application (see Figures K, M and N in Annex I).

Claims are “determined to be allowable/patentable” when the JPO examiner clearly identified the claims to be allowable/patentable in the latest office action, even if the application is not granted for patent yet. A claim determined as novel, inventive and industrially applicable by the JPO has the meaning of allowable/patentable for the purposes of this pilot program.

The office action includes:

- (a) Decision to Grant a Patent
- (b) Notification of Reasons for Refusal
- (c) Decision of Refusal

(d) Appeal Decision

For example, if the following routine expression is described in the “Notification of Reason for Refusal” of the JPO, those claims are clearly identified to be patentable/ allowable.

“<Claims which has been found no reason for refusal>

At present for invention concerning Claim___, no reason for refusal is found.”

(c) All claims on file, as originally filed or as amended, for examination under the PPH must sufficiently correspond to one or more of those claims indicated as allowable/patentable in the JPO.

Claims are considered to “sufficiently correspond” where, accounting for differences due to translations and claim format, the claims in the TURKPATENT are of the same or similar scope as the claims in the JPO, or the claims in the TURKPATENT are narrower in scope than the claims in the JPO. In this regard, a claim that is narrower in scope occurs when a JPO claim is amended to be further limited by an additional feature that is supported in the specification (description and/or claims).

A claim in the TURKPATENT which introduces a new/different category of claims to those claims indicated as allowable in the JPO is not considered to sufficiently correspond. For example, where the JPO claims only contain claims to a process of manufacturing a product, then the claims in the TURKPATENT are not considered to sufficiently correspond if the TURKPATENT claims introduce product claims that are dependent on the corresponding process claims.

Any claims amended or added after the grant of the request for participation in the PPH pilot program need not sufficiently correspond to the claims indicated as allowable in the JPO application.

(d) The TURKPATENT has not begun substantive examination of the application at the time of request for the PPH.

2. Documents to be submitted

Documents (a) to (d) below must be submitted by attaching to the PPH request form in filing a request under PPH.

(a) Copies of all office actions (which are relevant to substantial examination for patentability in the JPO) which were issued for the corresponding application by the JPO and translations of them.

Either Turkish or English is acceptable as translation language¹. The applicant does not

¹ Machine translations will be admissible, but if it is impossible for the examiner to understand the outline of the translated office action or claims due to insufficient translation, the applicant may be requested to resubmit translations.

have to submit a copy of JPO office actions and translations of them when those documents are provided via JPO's dossier access systems because the office actions and their machine translations are available for the TURKPATENT examiner via the JPO's dossier access systems. If they cannot be obtained by the TURKPATENT examiner via the JPO's dossier access systems, the applicant may be notified and requested to provide the necessary documents.

(b) Copies of all claims determined to be patentable/allowable by the JPO and translations of them.

Either Turkish or English is acceptable as translation language. The applicant does not have to submit a copy of claims indicated to be patentable/allowable in the JPO, and translations thereof when the documents are provided via JPO's dossier access systems because the claims and their machine translations are available for the TURKPATENT examiner via the JPO's dossier access systems. If they cannot be obtained by the TURKPATENT examiner via the JPO's dossier access systems, the applicant may be notified and requested to provide the necessary documents.

(c) Copies of references cited by the JPO examiner

If the references are patent documents, the applicant doesn't have to submit them because the TURKPATENT usually possesses them. When the TURKPATENT does not possess the patent document, the applicant has to submit the patent document at the examiner's request. Non-patent literature must always be submitted.

The translations of the references are unnecessary.

(d) Claim correspondence table

The applicant requesting PPH must submit a claim correspondence table, which indicates how all claims in the TURKPATENT application sufficiently correspond to the patentable/allowable claims in the JPO application.

When claims are just literal translation, the applicant can just write down that "they are the same" in the table. When claims are not just literal translation, it is necessary to explain the sufficient correspondence of each claim.

When the applicant has already submitted above documents (a) to (d) to the TURKPATENT through simultaneous or past procedures, the applicant may incorporate the documents by reference and does not have to attach them.

3. Procedure for the accelerated examination under the PPH pilot program

The TURKPATENT decides whether the application can be entitled to the status for an accelerated examination under the PPH when it receives a request with the documents stated above. When the TURKPATENT decides that the request is acceptable, the application is assigned a special status for an accelerated examination under the PPH.

In those instances where the request does not meet all the requirements set forth above, the applicant will be notified and the defects in the request will be identified. Before the issue of the notification of not assigning a special status for accelerated examination under the PPH, the applicant will be given opportunity to submit missing documents. Even after the issue of the notification of not assigning a special status for accelerated examination under the PPH, the applicant can request the PPH once again in a renewed request for participation.

If all requirements for accelerated examination under the PPH are met, the TURKPATENT will notify the applicant that the application has been allowed entry on to the PPH.

Part II

PPH using the PCT international work products from the JPO (PCT-PPH)

1. Requirements

The application which is filed with the TURKPATENT and on which the applicant files a request under the PCT-PPH must satisfy the following requirements:

- (1) The latest work product in the international phase of a PCT application corresponding to the application (“international work product”), namely the Written Opinion of International Search Authority (WO/ISA), the Written Opinion of International Preliminary Examination Authority (WO/IPEA) or the International Preliminary Examination Report (IPER), indicates at least one claim as patentable/allowable (from the aspect of novelty, inventive steps and industrial applicability).**

Note that the ISA and the IPEA which produced the WO/ISA, WO/IPEA and the IPER are limited to the JPO, but, if priority is claimed, the priority claim can be to an application in any Office, see example (A') in Annex II (application ZZ can be any national application).

The applicant cannot file a request under PCT-PPH on the basis of an International Search Report (ISR) only.

In case any observation is described in Box VIII of WO/ISA, WO/IPEA or IPER which forms the basis of a PCT-PPH request, the applicant must explain why the claim(s) is/are not subject to the observation irrespective of whether or not an amendment is submitted to correct the observation noted in Box VIII. The application will not be eligible for participating in PCT-PPH pilot program if the applicant does not explain why the claim(s) is/are not subject to the observation. In this regard, however, it does not affect the decision on the eligibility of the application whether the explanation is adequate and/or whether the amendment submitted overcomes the observation noted in Box VIII.

- (2) The relationship between the application and the corresponding international application satisfies one of the following requirements:**

(Case I)The application is a national phase application of the corresponding international application. (See Figures (A), (A'), and (A'') in Annex II)

(Case II)The application is a national application as a basis of the priority claim of the corresponding international application. (See Figure (B) in Annex II)

(Case III)The application is a national phase application of an international application claiming priority from the corresponding international application. (See Figure (C) in Annex II)

(Case IV)The application is a national application claiming foreign priority from the corresponding international application. (See Figure (D) in Annex II)

(Case V)The application is the derivative application (divisional application and application claiming priority etc.) of the application which satisfies one of the above requirements (Case I) – (Case IV). (See Figures (E1) and (E2) in Annex II)

- (3) All claims on file, as originally filed or as amended, for examination under the PCT-PPH must sufficiently correspond to one or more of those claims indicated as allowable in the latest international work product of the corresponding international application.**

Claims are considered to "sufficiently correspond" where, accounting for differences due to translations and claim format, the claims in the TURKPATENT are of the same or similar scope as the claims indicated as allowable in the latest international work product, or the claims in the TURKPATENT are narrower in scope than the claims indicated as allowable in the latest international work product.

In this regard, a claim that is narrower in scope occurs when a claim indicated as allowable in the latest international work product is amended to be further limited by an additional feature that is supported in the specification (description and/or claims).

A claim in the TURKPATENT which introduces a new/different category of claims to those claims indicated as allowable in the latest international work product is not considered to sufficiently correspond. For example, where the claims indicated as allowable in the latest international work product only contain claims to a process of manufacturing a product, then the claims in the TURKPATENT are not considered to sufficiently correspond if the TURKPATENT claims introduce product claims that are dependent on the corresponding process claims.

Any claims amended or added after the grant of the request for participation in the PCT-PPH pilot program must sufficiently correspond to the claims indicated as allowable in the latest international work product.

- (4) The TURKPATENT has not begun substantive examination of the application at the time of request for the PPH.**

2. Documents to be submitted

The applicant must submit the following documents attached to the PPH request form in filing a request under PCT-PPH. Some of the documents may not be required to submit in certain cases.

- (1) A copy of the latest international work product which indicated the claims to be**

patentable/allowable and translations of them².

Either Turkish or English is acceptable as translation language. If the copy of the latest international work product is available in English via "PATENTSCOPE (registered trademark)"³, an applicant need not submit these documents unless otherwise requested by the TURKPATENT (WO/ISA and IPER are usually available as "IPRP Chapter I" and "IPRP Chapter II" respectively in 30 months after the priority date).

(2) A copy of a set of claims which the latest international work product of the corresponding international application indicated to be patentable/allowable and translations of them.

Either Turkish or English is acceptable as translation language. If the copy of the set of claims which are indicated to be patentable/allowable is available in English via "PATENTSCOPE (registered trademark)" (e.g. the international Patent Gazette has been published), an applicant need not submit this document unless otherwise requested by the TURKPATENT.

(3) A copy of references cited in the latest international work product of the international application corresponding to the application.

If the reference is a patent document, the applicant is not required to submit it. In case the TURKPATENT has difficulty in obtaining the document, however, the applicant may be asked to submit it. Non-patent literature must always be submitted. Translations of cited references are unnecessary.

(4) A claims correspondence table which indicates how all claims in the application sufficiently correspond to the claims indicated to be patentable/allowable.

When claims are just literal translation, the applicant can just write down that "they are the same" in the table. When claims are not just literal translation, it is necessary to explain the sufficient correspondence of each claim.

When an applicant has already submitted the above mentioned documents (1) - (4) to TURKPATENT the through simultaneous or past procedures, the applicant may incorporate the documents by reference and is thus not required to attach the documents.

² Machine translations will be admissible, but if it is impossible for the examiner to understand the outline of the translated office action or claims due to insufficient translation, the examiner can request the applicant to resubmit translations.

³ <http://www.wipo.int/pctdb/en/index.jsp>

3. Procedure for the accelerated examination under the PPH pilot program

The TURKPATENT decides whether the application can be entitled to the status for an accelerated examination under the PPH when it receives a request with the documents stated above. When the TURKPATENT decides that the request is acceptable, the application is assigned a special status for an accelerated examination under the PPH.

If all requirements for accelerated examination under the PPH are met, the TURKPATENT will notify the applicant that the application has been allowed entry on to the PPH.

4. TURKPATENT PPH request form

REQUEST FOR PARTICIPATION IN THE PATENT PROSECUTION HIGHWAY (PPH) PILOT PROGRAM	
A. Bibliographic Data	
Application Number (if known)	
Applicant's name	
Title of invention	
B. Request	
Applicant requests participation in the Patent Prosecution Highway (PPH) pilot program based on:	
Office of Earlier Examination (OEE)	JPO
OEE Work Products Type	<input type="checkbox"/> PPH (National Office Action) <input type="checkbox"/> PCT-PPH (WO-ISA, WO-IPEA or IPER)
OEE Application Number	
Priority Application Number or PCT Application Number	
C. Required Documents	
I. OEE Work Products and, if required, Translations	
1. <input type="checkbox"/> A copy of OEE work products is attached; or <input type="checkbox"/> The office is requested to retrieve documents via the Dossier Access System or PATENTSCOPE	
2. <input type="checkbox"/> A translation of documents in 1 in a language accepted by the Office is attached; or <input type="checkbox"/> The office is requested to retrieve documents via the Dossier Access System or PATENTSCOPE	
II. Patentable/Allowable Claims Determined by OEE and, if required, Translations	
3. <input type="checkbox"/> A copy of all claims determined to be patentable/allowable by OEE is attached; or <input type="checkbox"/> The office is requested to retrieve documents via the Dossier Access System or PATENTSCOPE	
4. <input type="checkbox"/> A translation of documents in 3 in a language accepted by the Office is attached; or <input type="checkbox"/> The office is requested to retrieve documents via the Dossier Access System or PATENTSCOPE	
III. Documents Cited in OEE Work Products (if required)	
5. <input type="checkbox"/> A copy of all documents cited in OEE work products is attached (excluding patent documents); or <input type="checkbox"/> no references cited	
IV. Previously submitted documents	
6. <input type="checkbox"/> If any of the above mentioned documents have been submitted before, please specify:	

D. Claims Correspondence

All the claims in the application sufficiently correspond to the patentable/allowable claims in the OEE application; or

Claims correspondence is explained in the following table

Application Claims	Corresponding OEE claims	Explanation regarding the correspondence

Name(s) of applicant(s) or representative(s)

Date

A A case meeting requirement (a) (I)
- Paris route -

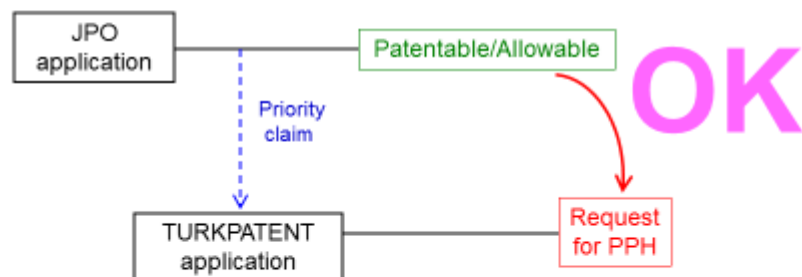

B A case meeting requirement (a) (I)
- PCT route -

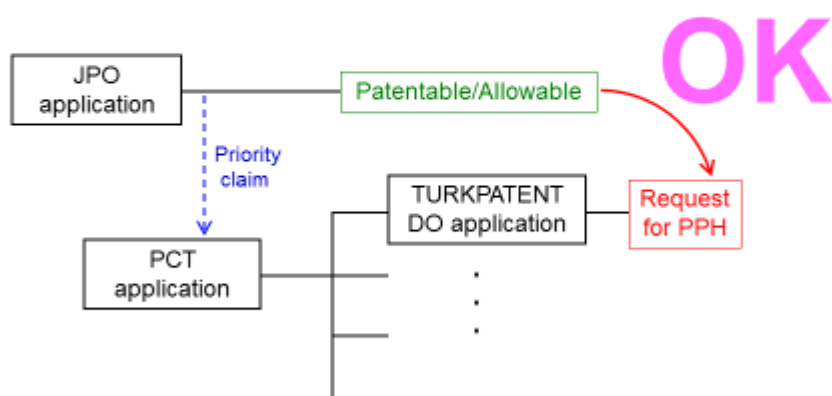

C A case meeting requirement (a) (I)
- PCT route, Domestic priority -

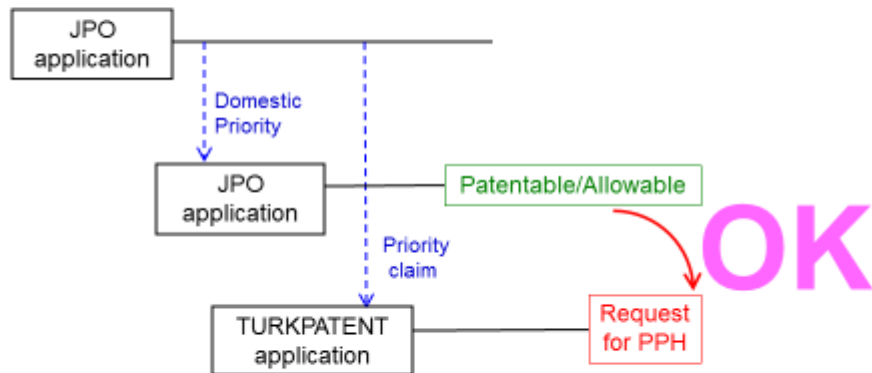

D A case meeting requirement (a) (II)
- Paris route -

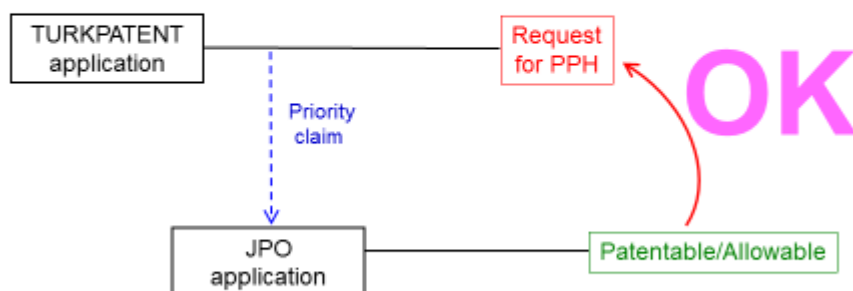

E A case meeting requirement (a) (II)
- PCT route -

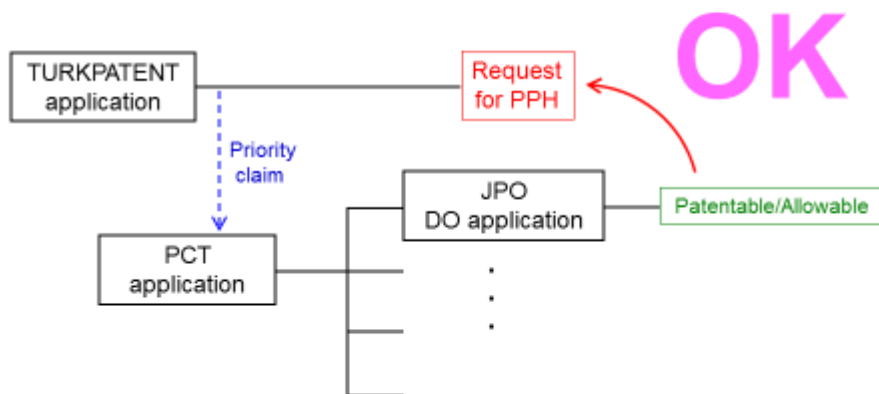

F A case meeting requirement (a) (III)
- Paris route, but the first application is from the third country -

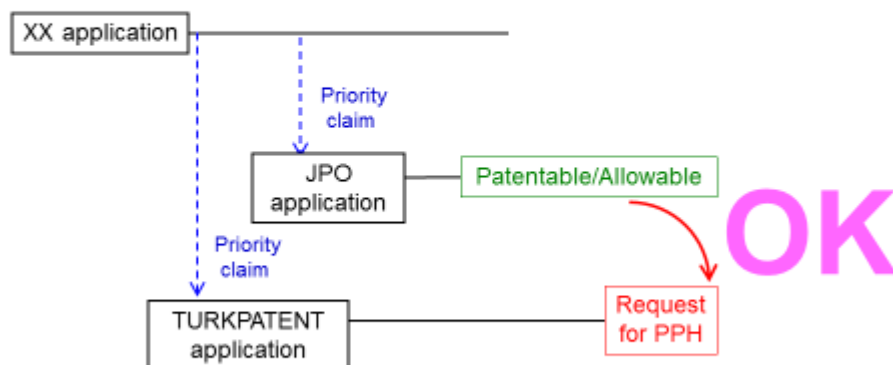

XX : the office other than the JPO

G

A case meeting requirement (a) (III)

- PCT route, but the first application is from the third country -

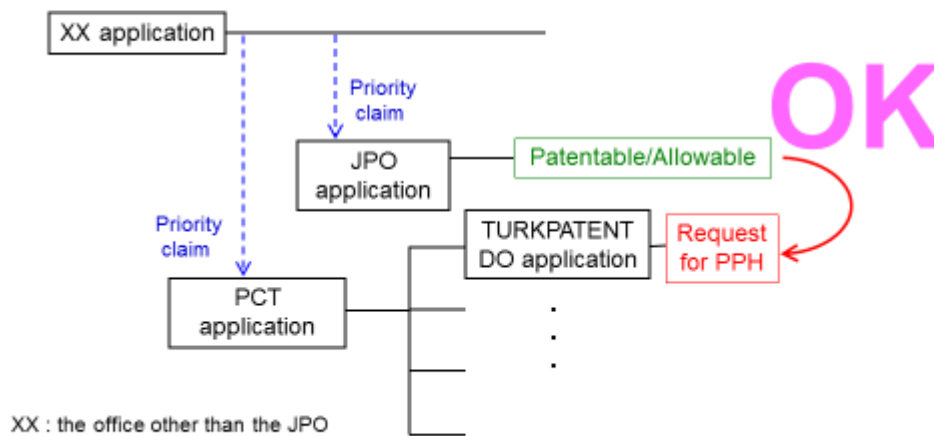

H

A case meeting requirement (a) (I)

- Paris route & Complex priority -

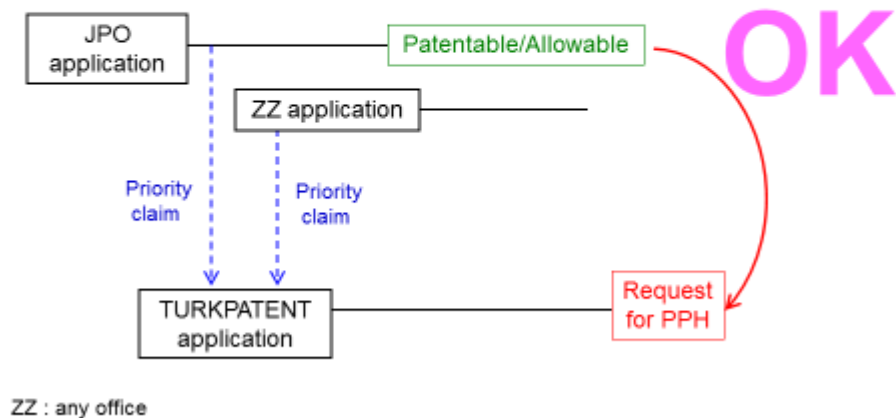

I A case meeting requirement (a) (I)
- Paris route & divisional application -

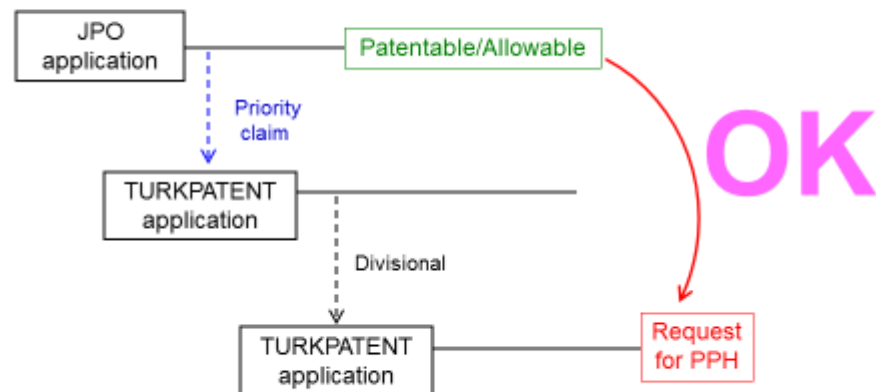

J A case meeting requirement (a) (I)
- PCT route -

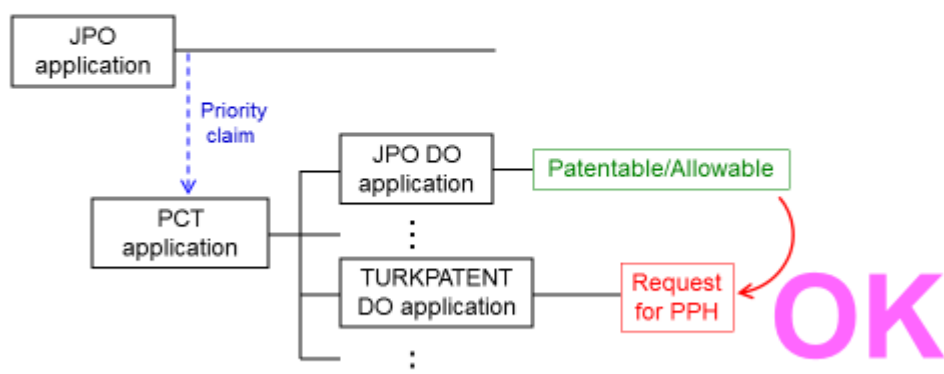

K A case meeting requirement (a) (IV)
- Direct PCT route -

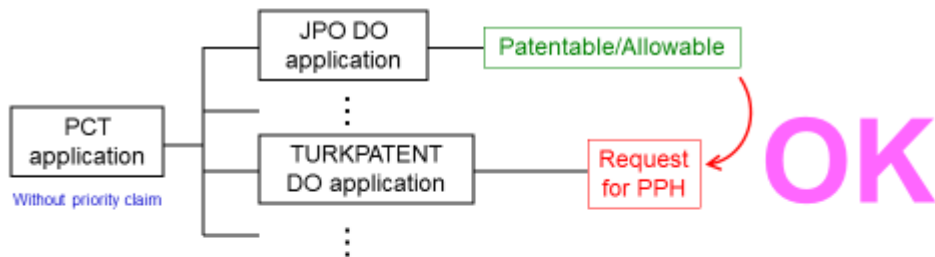

L A case meeting requirement (a) (III)
- Direct PCT & Paris route -

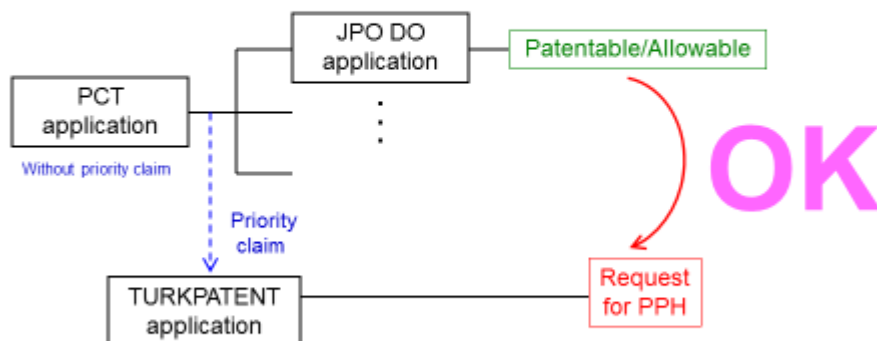

M A case meeting requirement (a) (III)
- Direct PCT & PCT route -

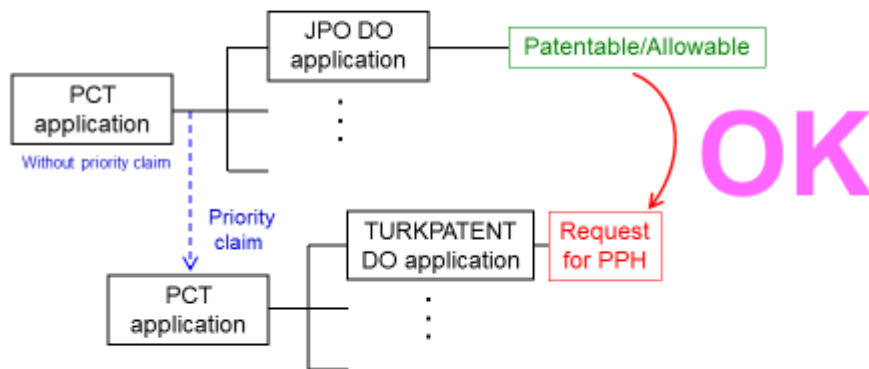

N A case meeting requirement (a) (III)
- Direct PCT & PCT route -

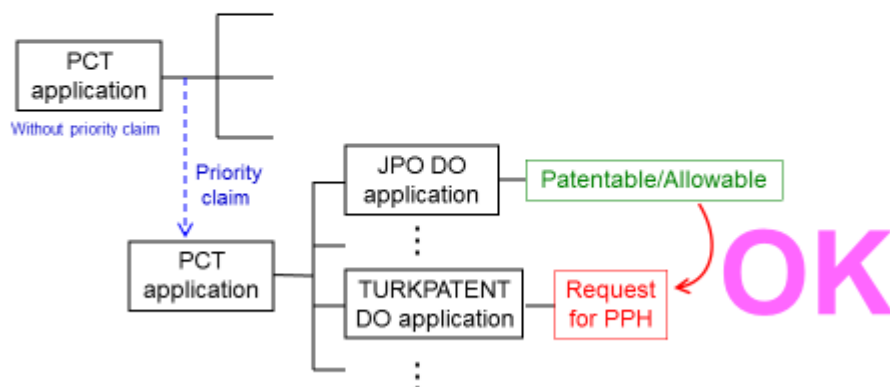

(A) The application is a national phase application of the corresponding international application.

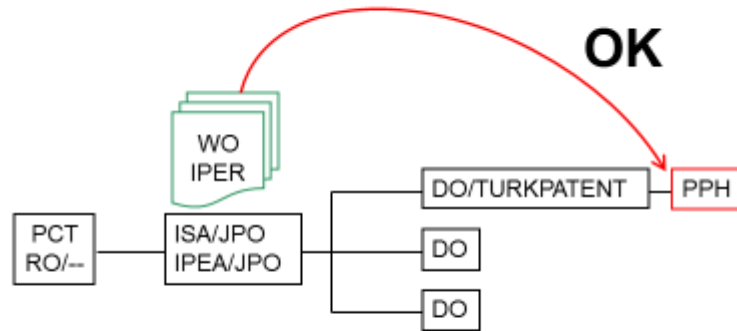

(A') The application is a national phase application of the corresponding international application.
 (The corresponding international application claims priority from a national application.)

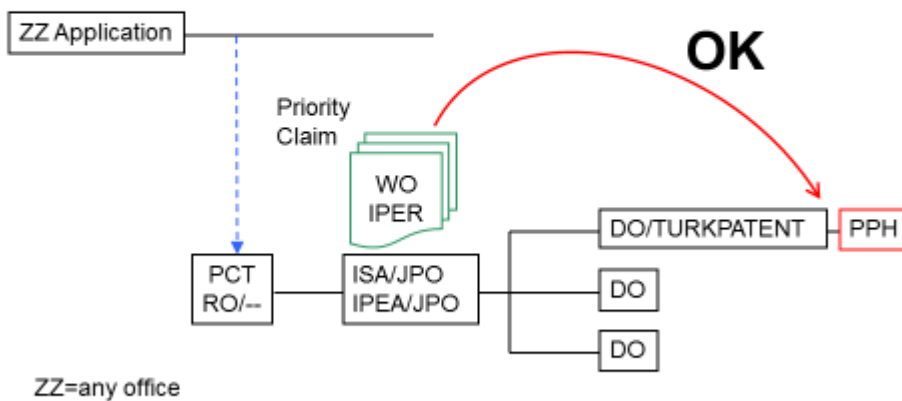

(A'') The application is a national phase application of the corresponding international application.
 (The corresponding international application claims priority from an international application.)

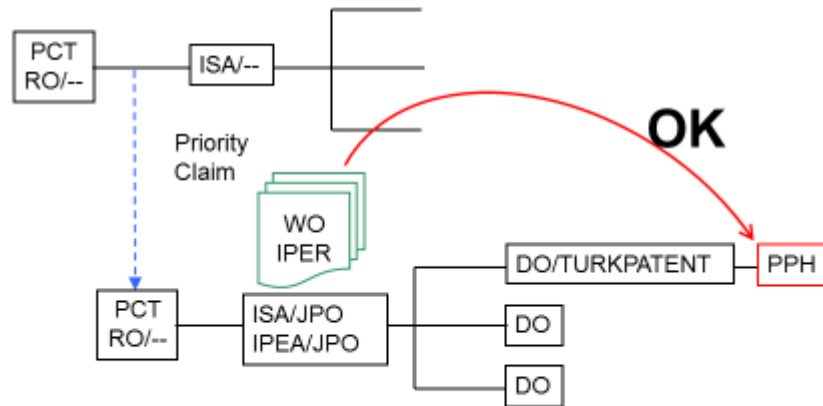

(B) The application is a national application as a basis of the priority claim of the corresponding international application.

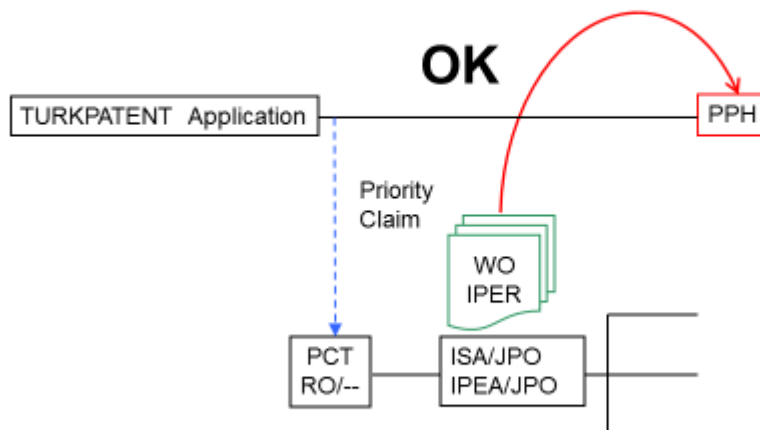

- (C) The application is a national phase application of an international application claiming priority from the corresponding international application.

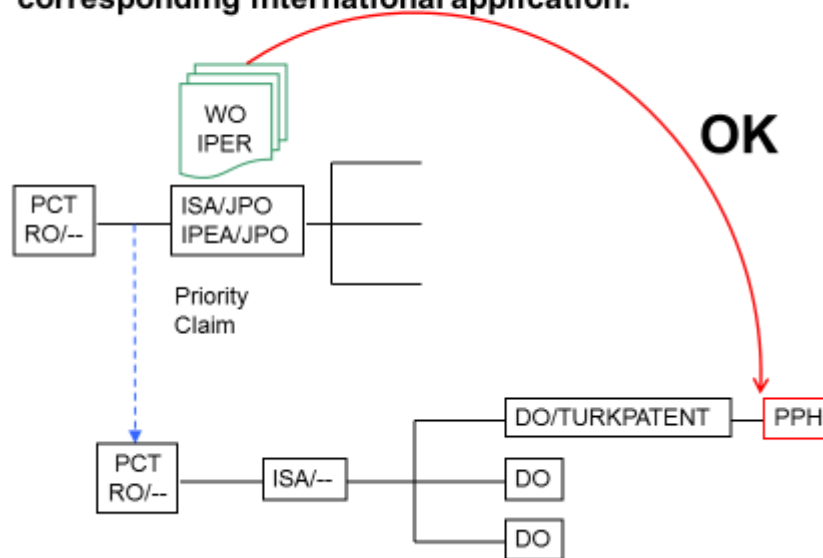

- (D) The application is a national application claiming foreign/domestic priority from the corresponding international application.

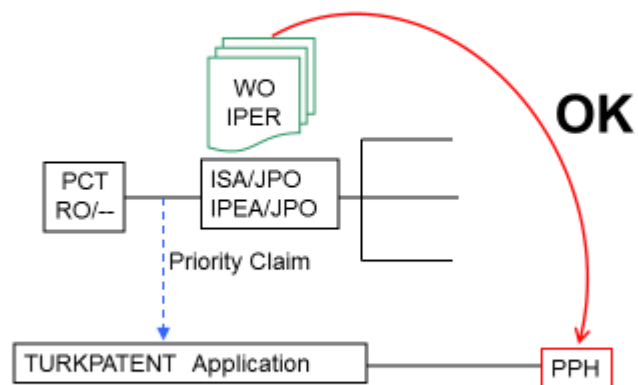

(E1) The application is a divisional application of an application which satisfies the requirement (A).

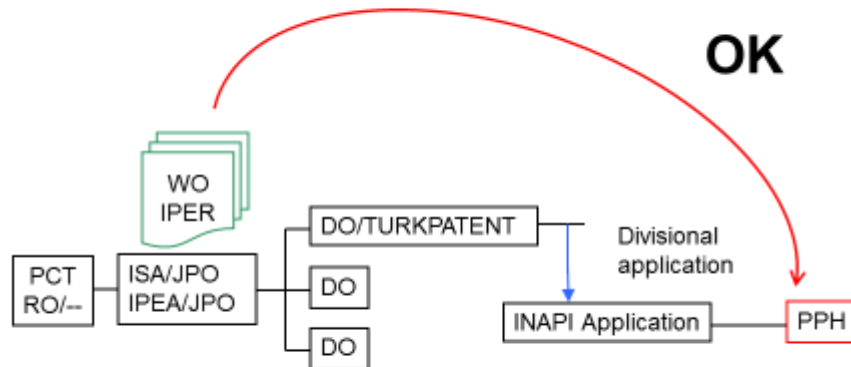

(E2) The application is an application claiming domestic priority from an application which satisfies the requirement (B).

