

# Case Summary

## ● Pony Corporation ("Pony")

Patent holder of an invention relating to a hollow golf club head (the "Invention")

- Patent Number: 20201028
- Filing Date: January 11, 2002
- Registration Date: September 30, 2005

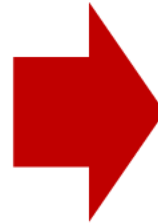

## ● Donkey Corporation ("Donkey")

Corporation selling golf clubs with the product name "Super IP 2020" (the "Defendant's Products")

- Manufacturing and selling the "Defendant's Products" since April 20, 2017

On December 12, 2019, Pony filed a patent infringement lawsuit against Donkey, seeking:

- Injunction against manufacture and sale of the Defendant's Products
- Compensation of damages in an amount of USD 5 million

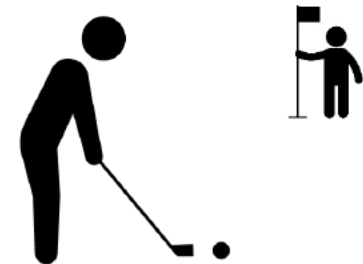

# What is a hollow golf club head?

## Hollow Golf Club Head :

Center of gravity can be set arbitrarily based on the combination of metallic/resin materials or the shape, and the head volume can be maximized within the limited scope of the head weight (head mass); enabling improvement of the performance of golf clubs in terms of, among others, flying distance and direction (See [0002])

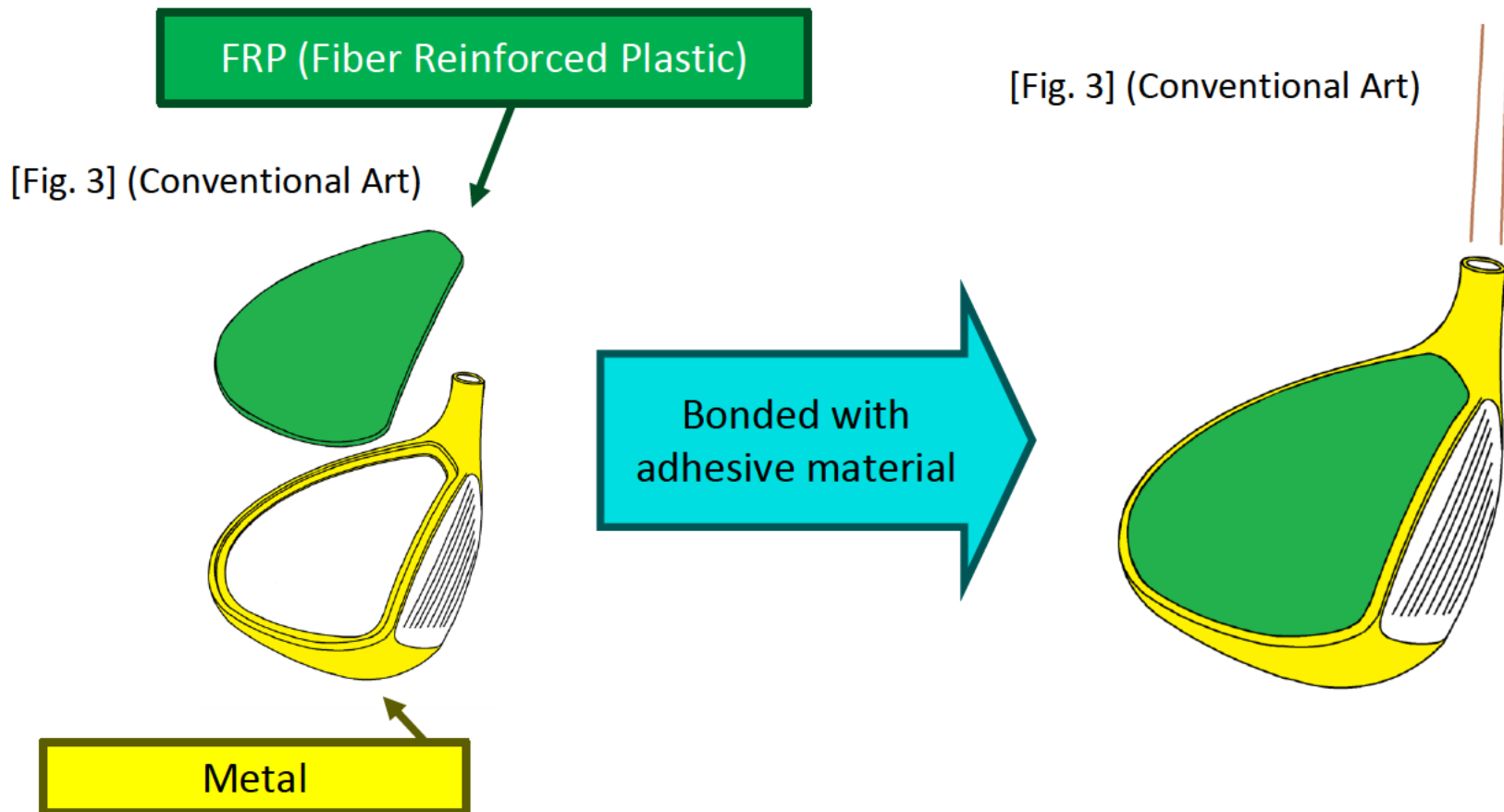

# Problem with Conventional Art / Objective of this Invention

[Fig. 3] (Conventional Art)

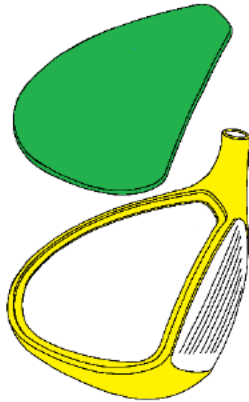

[Fig. 3] (Conventional Art)

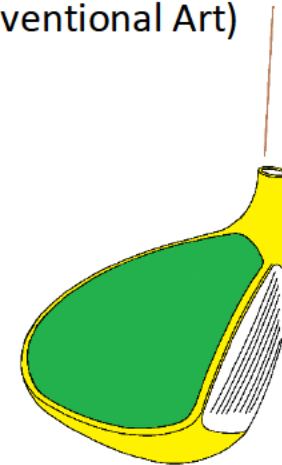
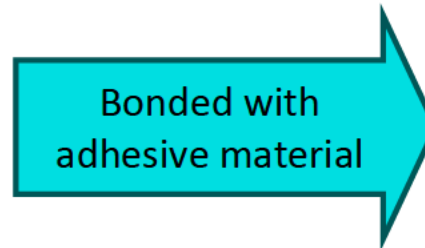

## Problem:

Depending on the metallic material used for the **metallic outer shell member**, there was difficulty in achieving sufficient bonding strength, thus **it was not possible** to ensure durability as a golf club head, when **only adhesive material alone** was used to bond the **FRP outer shell member** to the **metallic outer shell member**. (See [0003])

## Objective:

To provide a hollow golf club head capable of enhancing the bonding strength of a **metallic outer shell member** and an **FRP outer shell member**, regardless of the kind of the metallic material used in the **metallic outer shell member**. (See [0004])

# Claim

- F** A hollow golf club head, comprising
- A** a head body having a hollow structure and formed by coupling together a **metallic outer shell member** and a **fiber reinforced plastic (FRP) outer shell member** at their respective bonding portions, wherein;
- B** a plurality of through-holes are provided in the bonding portion of the **metallic outer shell member**;
- D** the **bonding portion of the metallic outer shell member** is bonded to the bonding portion of the **FRP outer shell member**
- C** by interposing an FRP thread member along with **adhesive material** between the **metallic outer shell member** and the **FRP outer shell member**, the **FRP thread member** maintaining a shape of passing through the plurality of the through-holes and running alternately on inner and outer surfaces of the **metallic outer shell member**; and
- E** each matrix of the **FRP outer shell member** and the **FRP thread member** contains epoxy resin.

(Note) Due to the translation from Japanese to English, the claim elements A to F are not in alphabetical order.

# Key Elements of Claimed Invention

- B a plurality of through-holes are provided in the **bonding portion of the metallic outer shell member**
  
- C by interposing an FRP thread member along with **adhesive material** between the **metallic outer shell member** and the **FRP outer shell member**, the **FRP thread member** maintaining a shape of passing through the plurality of the through-holes and running alternately on inner and outer surfaces of the **metallic outer shell member**
  
- E each matrix of the **FRP outer shell member** and the **FRP thread member** contains epoxy resin

# Outline of the Invention (1)

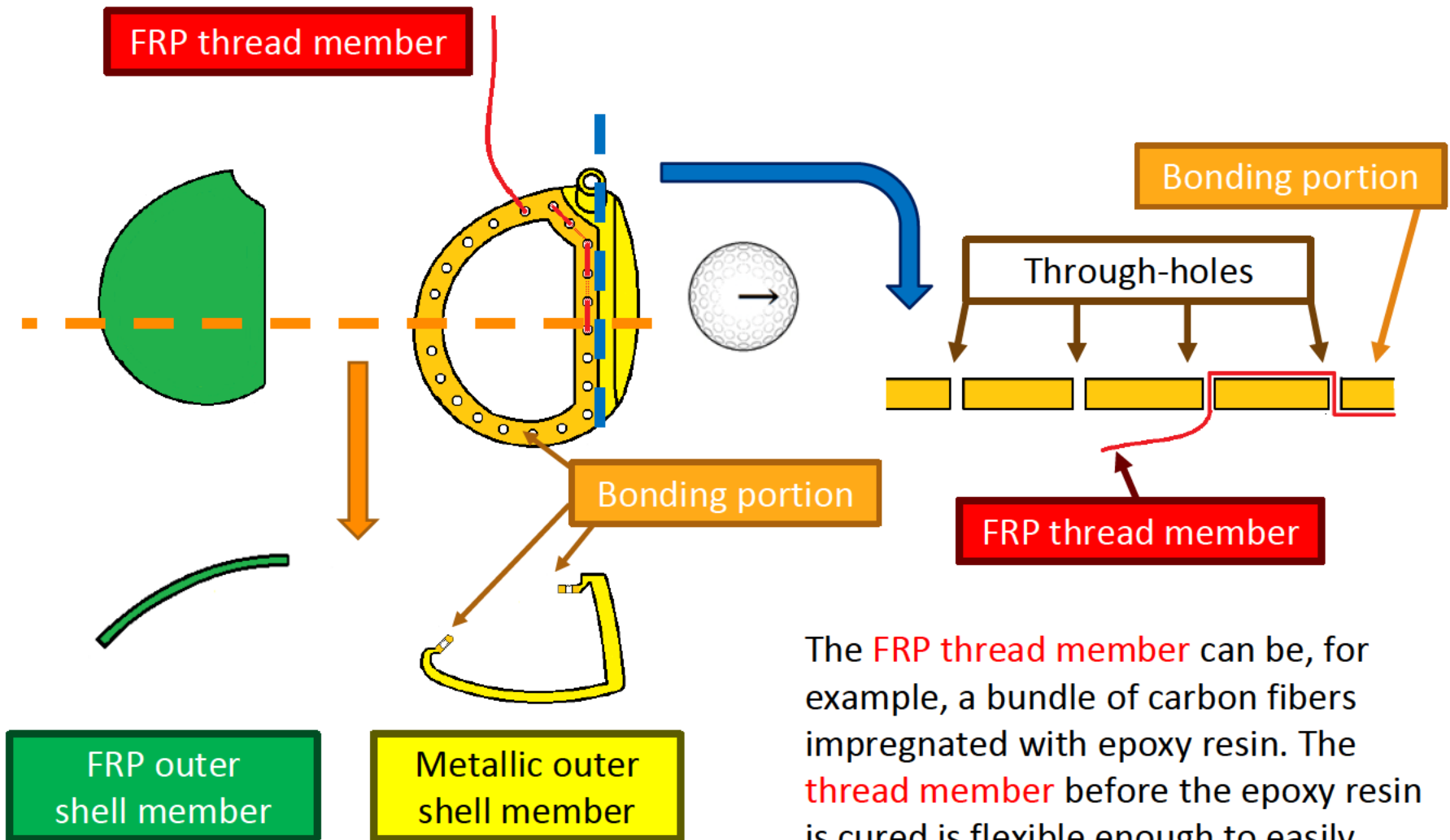

The **FRP thread member** can be, for example, a bundle of carbon fibers impregnated with epoxy resin. The **thread member** before the epoxy resin is cured is flexible enough to easily pass through the through-holes. (See [0011])

# Outline of the Invention (2)

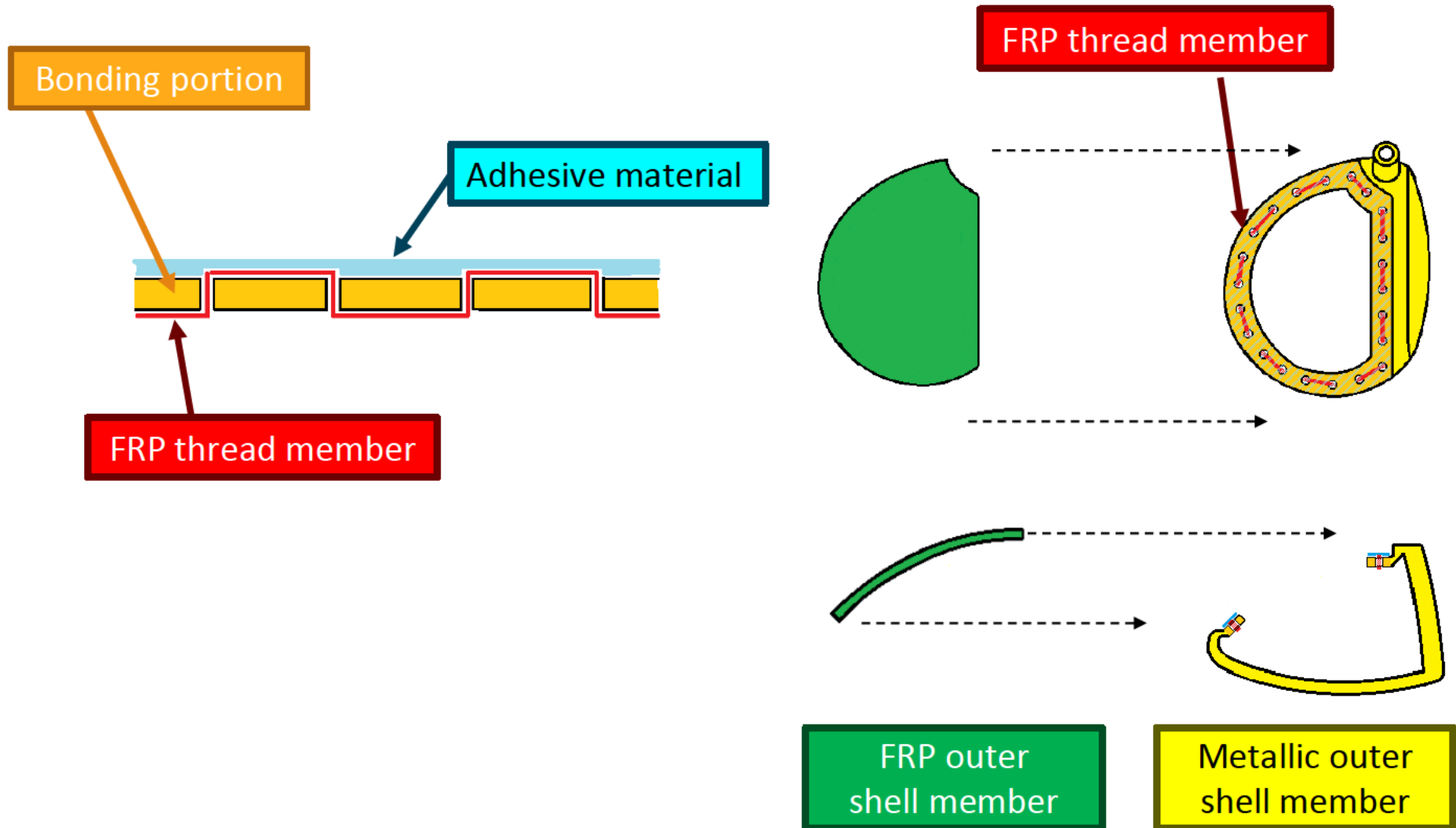

# Outline of the Invention (3)

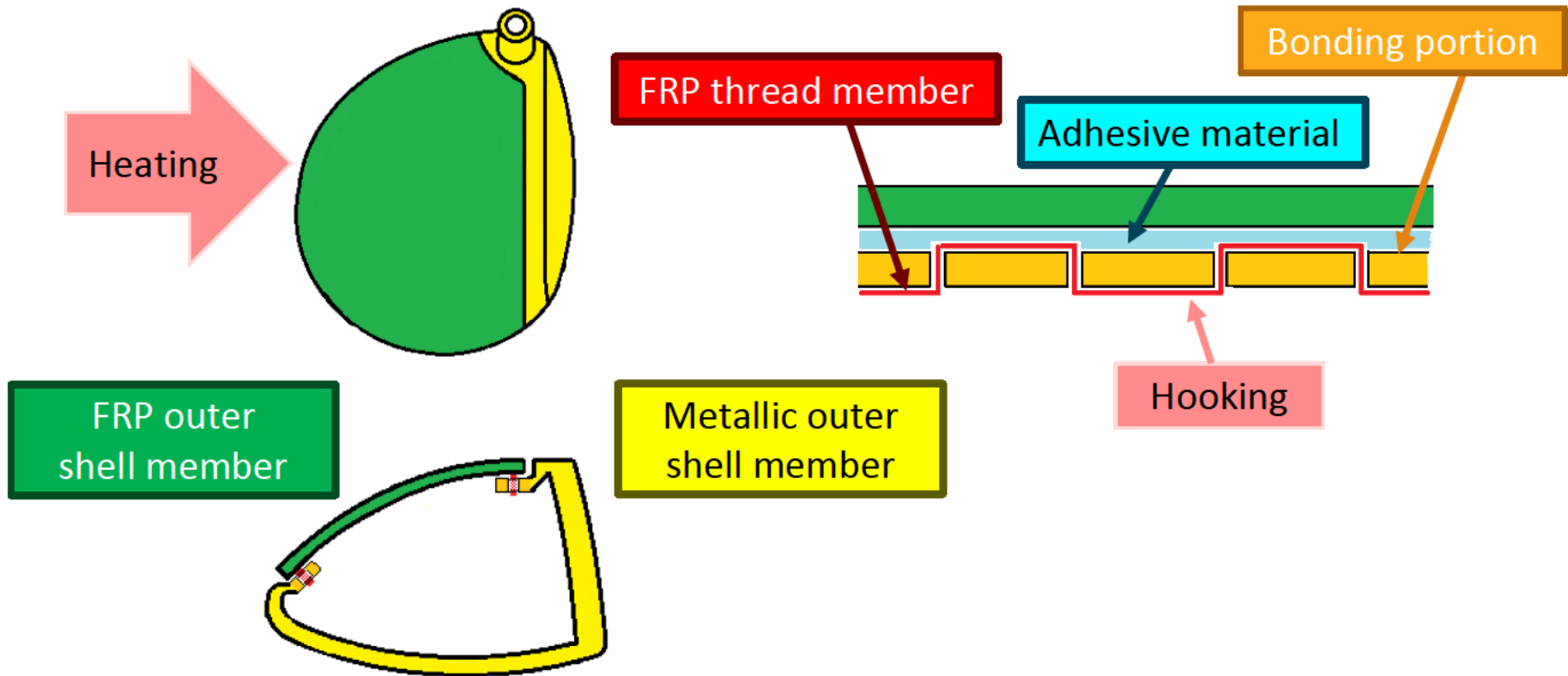

When the FRP outer shell member is bonded to the metallic outer shell member with the adhesive material at their respective bonding portions, and then the head body is heated while appropriately applying pressure on the two bonding portions, the epoxy resin of the thread member is cured to form one body with the epoxy resin of the FRP outer shell member, and the thread member is tightly bonded to the FRP outer shell member. (See [0013])



# “Element C” of Claim

## Element C

by interposing an FRP thread member along with the adhesive material between the metallic outer shell member and the FRP outer shell member, the FRP thread member maintaining a shape of passing through the plurality of the through-holes and running alternately on inner and outer surfaces of the metallic outer shell member

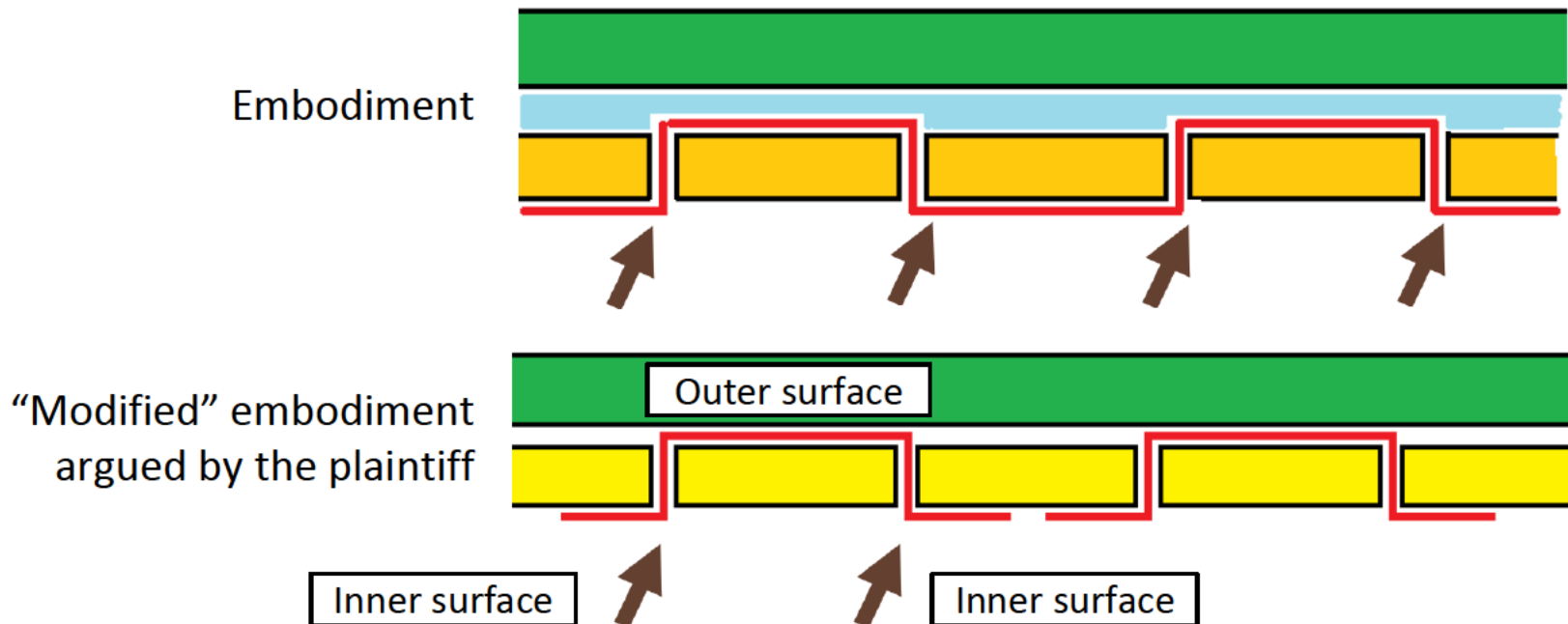

# Prosecution History (Amendment)

Element C of Original Claim

... an FRP thread member maintaining a shape of passing through the plurality of the through-holes; and

**Office Action (Notice of reason for refusal): Lack of clarity**

“The structure of how the FRP thread member passes through the plurality of through-holes is unclear.”

Element C of Amended Claim

... an FRP thread member maintaining a shape of passing through the plurality of the through-holes and running alternately on inner and outer surfaces of the metallic outer shell member; and

Concurrently, the same amendment was made to paragraph [0005] of the original specification.

# Outline of Defendant's Product (1)

[Fig. 1]

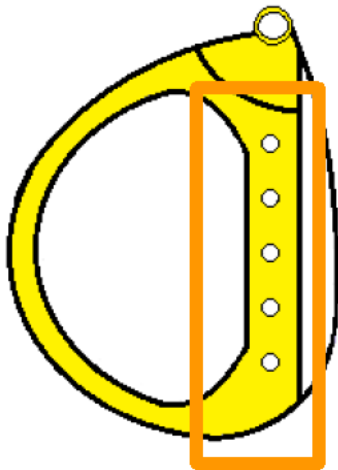

[Fig. 2]

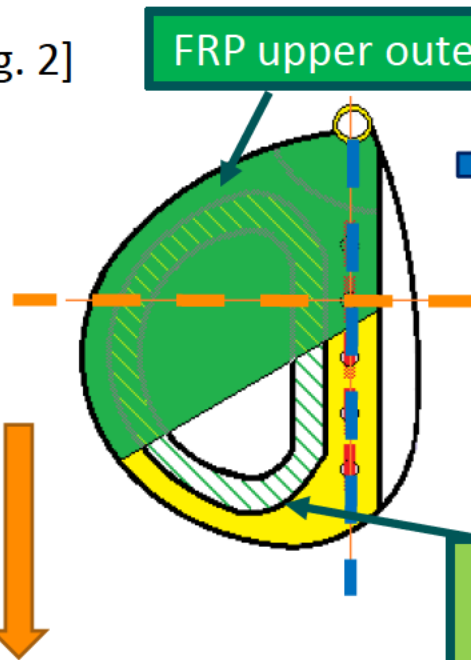

[Fig. 5]

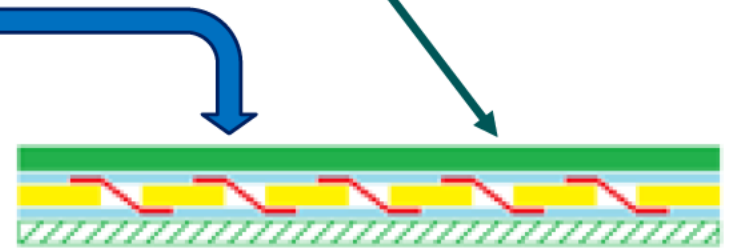

Metallic outer shell member 1

[Fig. 3]

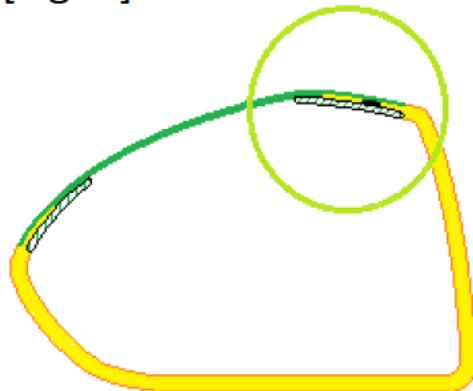

[Fig. 4]

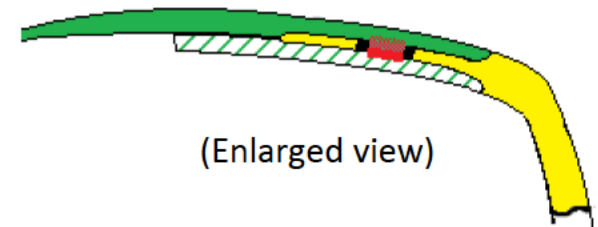

(Enlarged view)

# Outline of Defendant's Product (2)

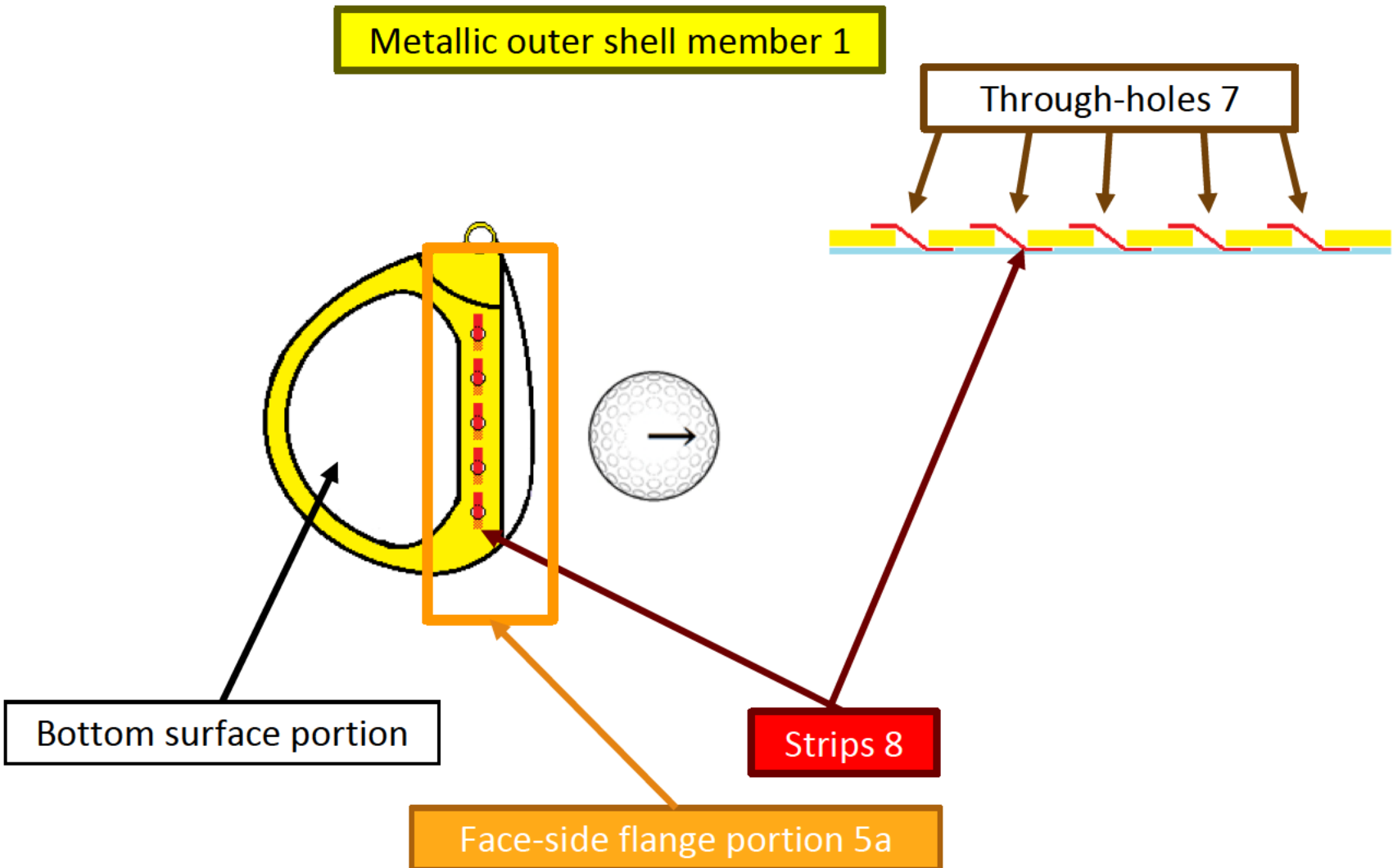

# Outline of Defendant's Product (3)

[Fig. 1]

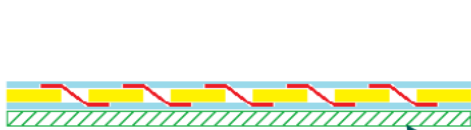

FRP upper outer shell member 10

[Fig. 2]



FRP lower outer shell member 9

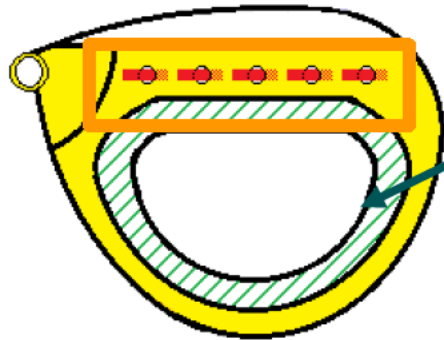
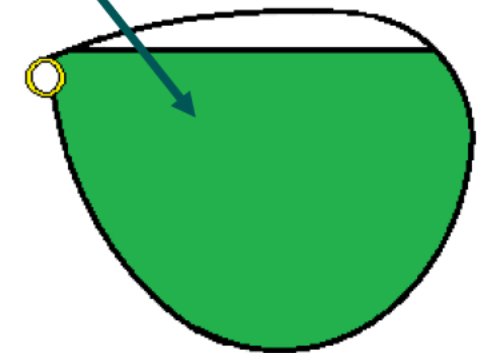

Metallic outer shell member 1

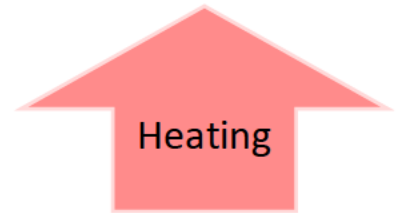

# Corresponding Elements in Defendant's Product

- <a> A head body having a hollow structure and formed by coupling together a metallic outer shell member 1 and fiber reinforced plastic (FRP) outer shell members 9 and 10 at the respective bonding portions of a flange portion 5 of the metallic outer shell member 1, and the FRP outer shell members 9 and 10;
- <b> five through-holes 7 are provided in a face-side flange portion 5a of the metallic outer shell member 1;
- <c> each of five short and small strips 8 made of FRP passes through a through-hole 7, and the FRP strips 8 are aligned to form a line in a longitudinal direction of the face-side flange portion 5a so that:
  - each of the proximal portions of the FRP strips 8 to the shaft connecting part is placed on the upper surface side of the face-side flange portion 5a, and the FRP strips 8 penetrate the respective through-holes 7, and each of the distal portions of the FRP strips 8 is placed on the lower surface side of the face-side flange portion 5a;
  - the FRP strips 8 are interposed, along with adhesive material, between the upper surface side of the flange portion 5 of the metallic outer shell member 1 and the bonding portion of the FRP upper outer shell member 10, and between the lower surface side of the flange portion 5 of the metallic outer shell member 1 and the bonding portion of the FRP lower outer shell member 9 in the shape as shown in FIG. 3; and
  - by applying heat and pressure to the FRP outer shell members 9 and 10, the epoxy resin impregnated in each strip is cured together with the epoxy resin contained in the adhesive material so as to maintain the above shape of the FRP strips 8;
- <d> the respective bonding portions of the flange portion 5 of the metallic outer shell member 1, and the FRP lower outer shell member 9 and the FRP upper outer shell member 10 are bonded; and
- <e> each matrix of the FRP outer shell members 9 and 10, and the FRP strips 8 contains epoxy resin.
- <f> A hollow golf club head characterized as above.