



Japan Patent Office

fiveIPoffices

European Patent Office /// Japan Patent Office ///
Korean Intellectual Property Office /// State Intellectual
Property Office of the People's Republic of China ///
United States Patent and Trademark Office

Subject:

**Written Description/Sufficiency of Disclosure
Case Studies**

Document Number:

Document Date:

31 May 2019

Author:

JPO

Responsible:

JPO

Contents:

1. Case 4
 - (1) Hypothetical Case
 - (2) Case Study by IP5 Offices
2. Case 5
 - (1) Hypothetical Case
 - (2) Case Study by IP5 Offices
3. Case 6
 - (1) Hypothetical Case
 - (2) Case Study by IP5 Offices
4. Outline of IP5 Offices' Case Studies (Case 4-6)
5. Analysis on IP5 Offices' Case Studies (Case 4-6)
6. IP5 Users' Opinion on IP5 Offices' Case Studies (Case 4-6)
7. Summary of IP5 Offices' Case Studies (Case 4-6)

(NOTE)

1. In this case study, the purpose of the judgement by users and IP5 Offices focused on clarity and support requirement of claims.

2. The study reflects only a "snapshot" assessment, i.e. an assessment of the specifics outlined in the hypothetical cases, which is not representative enough to allow for valid general conclusions.

3. The result and summary of this case study have only indicative meanings, and are NOT legally binding on IP5 Offices.

1. Case 4

(1) Hypothetical Case

Case 4

[Claims]

1. A device for performing character input by touching a keyboard layout displayed on a touch screen, comprising:
a memory (34) for storing a plurality of different types of keyboard layouts,
touch detection means (31) for determining whether or not a touch has occurred in a predetermined area where no keys of the keyboard layout (15) are displayed on the touch screen (12); and
keyboard changing means (33) for changing a keyboard layout (15) displayed on the touch screen to another keyboard layout (15) stored in the memory (34) when the touch detection means (31) determines that a touch has occurred in the predetermined area.

[Description]

This invention relates to handheld portable terminals, such as smartphones and tablets, and functions as a character input device. The purpose of the claimed invention is to enable users to easily change the keyboard layout displayed on a touch screen of a device.

The invention is to provide a device for performing character input by touching a keyboard layout displayed on a touch screen, comprising: a memory (34) for storing a plurality of different types of keyboard layouts, touch detection means (31) for determining whether or not a touch has occurred in a predetermined area where no keys of the keyboard layout (15) are displayed on the touch screen (12); and keyboard changing means (33) for changing a keyboard layout (15) displayed on the touch screen to another keyboard layout (15) stored in the memory (34) when the touch detection means (31) determines that a touch has occurred. Specific embodiment of the invention is described as follows:

Figure 1 is a perspective view of "Smartphone 10," which is one of the embodiments of the present invention. As shown in Figure 1, Smartphone 10 comprises hardware operation keys 11, a touch screen 12, a microphone 17, and a speaker 18.

Smartphone 10 comprises plural modes for inputting characters, such as typing on a keyboard or making inputs by handwriting, and persons operating such devices can switch the modes. By using these operating modes, Smartphone 10 can function as a character input device. In the keyboard operating mode, Smartphone 10 displays a keyboard layout 15 on its touch screen 12 as shown in Figure 2. When users touch the keyboard layout 15 by using their fingers or a touch pen 20, characters can be input and displayed on another area of the touch screen 12.

Also, Smartphone 10 contains a CPU and a memory. The CPU is a processing unit that is used to execute programs stored in the memory. The CPU performs processing to control each part of Smartphone 10 and performs various functions described later. The memory stores programs and data to carry out the invention, and also acts as the working memory of the CPU.

The following are detailed explanations shown in Figure 3 about the processing when Smartphone 10 is in the keyboard operating mode:

Figure 3 is a diagram showing a part of the functional blocks of Smartphone 10. A touch detection unit 31 determines whether or not a touch by users has occurred in a predetermined area of the touch screen 12. This touch operation is an operation, in which

users touch a touch screen 12 with their fingers or by using a touch pen 20. The above mentioned predetermined area is an area where no keys of the keyboard layout 15 are displayed on the touch screen 12. This area is indicated with diagonal lines in Figure 2.

A keyboard changing unit 33 controls displaying the keyboard layout. When the touch detection unit 31 sends a signal indicating that a touch has occurred in the predetermined area, unit 33 changes the keyboard layout image 15 currently being displayed on the touch screen to another keyboard layout stored in the memory 34.

The following are more specific descriptions on the above mentioned control conducted by the keyboard changing unit 33. The memory 34 stores three types of keyboard layouts in the following order: "capital-letter alphabetic characters keyboard layout," "small-letter alphabetic characters keyboard layout," and "ten-key numerical characters keyboard layout." For example, in cases where a "capital-letter alphabetic keyboard layout" is displayed on the touch screen, if a signal that a touch has occurred is sent to the keyboard changing unit 33, the keyboard changing unit 33 will change the keyboard layout being displayed on the touch screen to either of the two other keyboard layouts, i.e. a "ten-key numerical characters keyboard layout" or a "small-letter alphabetic characters keyboard layout", stored next to this current keyboard layout in the memory 34.

[Drawings]

Fig.1

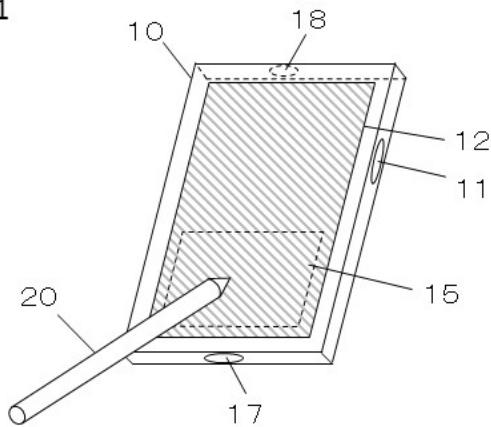

Fig.3

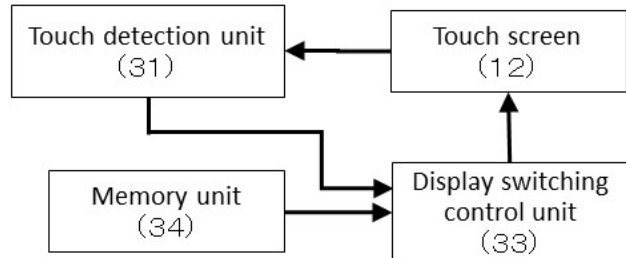
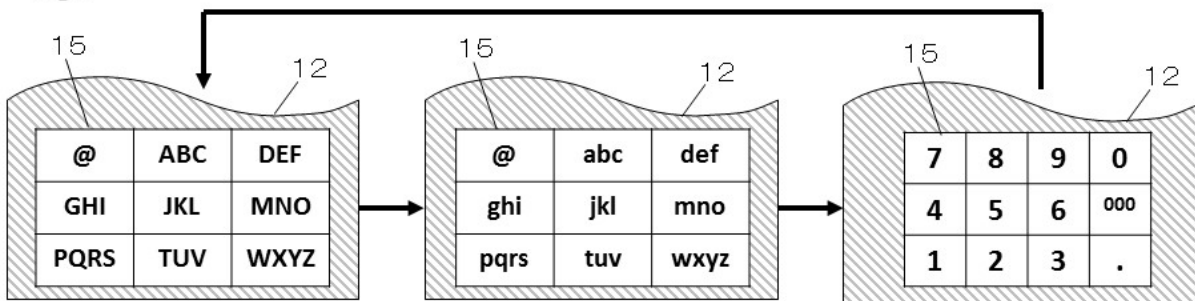

Fig.2



Issues to be Considered

- Is the invention of Claim 1 unclear because of the statement “means for ...” (*)?
- Does the invention of Claim 1 meet the support requirement?

(*) “touch detection means (31) for determining whether or not a touch has occurred in a predetermined area where no keys of the keyboard layout (15) are displayed on the touch screen (12)” and “keyboard changing means (33) for changing a keyboard layout displayed on the touch screen to another keyboard layout stored in the memory (34) when the touch detection means (31) determines that a touch has occurred in the predetermined area”

1. Case 4

(2) Case Study by IP5 Offices

Case Study 4 on Hypothetical Case

Name of Office: EPO

Please fill in the examination results at your office on the following issues to be considered:

1. Does the invention of Claim 1 meet the clarity requirement?

- Yes**
 No
 Both Yes and No

2. In Question 1 above, if you chose “Yes” (the claimed invention meets the clarity requirement) or “both Yes and No,” please provide the reasons for your response, in the space below:

The ‘means for’ formulation is well established in the Computer Implemented Inventions field. See GL, F-IV, 4.13: “in the data-processing/computer program field, apparatus features of the means-plus-function type (“means for ...”) are interpreted as means **adapted to** carry out the relevant steps/functions, rather than merely means suitable for carrying them out.” When reading the claim with a mind willing to understand, the limitations to the device are clearly deductible. The formulation leaves room for different implementations, e.g. by software, by dedicated hardware such as a processor or a combination thereof.

Regarding the first functional feature, namely:

“touch detection means (31) for determining whether or not a touch has occurred in a predetermined area where no keys of the keyboard layout (15) are displayed on the touch screen (12)”,

this feature is considered to be clear as the skilled person of the human machine interface, more specifically of the field of smart phones or tablets with touch screen (as mentioned in the opening paragraph of the description stating the field of the invention) would know how to design such “touch detection means”.

The function (conditional determination) performed by the touch operation detection means is also well and clearly specified.

For assessing clarity of functional claims EPO examiners refer to Article 84 EPC of the European Patent Convention (EPC) which reads: “The claims shall define the matter for which protection is sought. They shall be clear and concise and be supported by the description” and also in particular to the European Guidelines part F-IV 2.1 (“Functional features may be included provided that a skilled person would have no difficulty in providing some means of performing this function without exercising inventive skill”).

The second functional feature reads:

“keyboard changing means (33) for changing a keyboard layout (15) displayed on the touch screen to another keyboard layout (15) stored in the memory (34) when the touch detection means (31) determines that a touch has occurred in the predetermined area”.

As for the first functional feature the skilled person would easily understand the function of the display switching control means and how to design such a keyboard changing means to perform said function. The passage of this second functional feature: “when the touch detection means (31) judges that a touch has occurred in the predetermined area” teaches that the keyboard changing means changes the keyboard layout image only if a touch operation has been performed in a specified area where no keys of the keyboard layout image (15) are arranged on the touch screen. Therefore the touch operation is limited to the embodiment described on third paragraph of page 2 (corresponds to sixth paragraph) of the description, defining that the touch occurs in a specified area. The specified area being defined as follows: “The above mentioned specified area is an area where no keys of the keyboard layout image are arranged on the touch screen 12”.

Note: Even though in the field of CII the examiner would understand that “means for” in this functional feature should mean “means adapted to”, the applicant could have drafted the claims even more clearly by formulating the claim e.g. as “keyboard changing means (33) **adapted to** change a keyboard layout (15) displayed on the touch screen to another keyboard layout (15) stored in the memory (34) when the touch detection means (31) determines that a touch has occurred in the predetermined area”. The application describes one way of carrying out this adaptation paragraph 8, i.e. one way of adapting the keyboard changing means is included in the paragraph describing the sending of the signal between the touch detection unit and the keyboard changing unit.

3. In Question 1 above, if you chose “No” (the claimed invention does not meet the clarity requirement) or “both Yes and No,” please provide the reasons for your response, in the space below:
4. Does the invention of Claim 1 meet the support requirement?
 Yes
 No
 Both Yes and No
5. In Question 4 above, if you chose “Yes” (the claimed invention meets the support requirement) or “both Yes and No,” please provide the reasons for your response, in the space below:

The support requirement is defined by the same Article 84 EPC (“The claims shall define the matter for which protection is sought. They shall be clear and concise and be supported by the description”).

The EPO examiners compare the text of the claims with that of the description and detect for instance possible mismatch or inconsistencies.

EPO Guidelines further provide instructions to the examiners in section F-IV 6. The general instruction given in the EPO Guidelines reads: “The claims must be supported by the description. This means that there must be a basis in the description for the subject-matter of every claim and that the scope of the claims must not be broader than is justified by the extent of the description and drawings and also the contribution to the art”.

In the present case all the features specified in the claim and their respective function do have a basis in the description, namely:

The opening portion of the claim: “A character input device for performing character input by touching a keyboard layout image displayed on a touch screen” finds a basis in the first paragraph of page 2 (corresponds to fourth paragraph) of the description where the expression “a character input device” is literally present. The function of the input device is also supported by the same paragraph of the description together with figures 1 and 2.

The feature “memory” and its function “for storing plurality of different types of keyboard layout images” find support in the last paragraph of page 2 (corresponds to eighth paragraph) of the description (“The memory 34 stores three types of keyboard layout images ...”).

The feature: “touch detection means (31) for judging whether or not a touch has occurred in a predetermined area where no keys of the keyboard layout image (15) are displayed on the touch screen” is supported by text explaining figure 3 on page 2 (corresponds to figure 3) of the description.

The feature: “keyboard changing means (33) for changing a keyboard layout image (15) displayed in the touch screen to another keyboard layout image (15) stored in the memory (34) when the touch detection means (31) determines that a touch has occurred in the predetermined area” finds its support in the fourth paragraph of page 2 of the description. (“A keyboard changing unit 33 controls displaying the keyboard layout. When the touch detection unit 31 sends a signal indicating that a touch has occurred in the predetermined area, unit 33 changes the keyboard layout image 15 currently being displayed on the touch screen to another keyboard layout image stored in the memory 34”).

6. In Question 4 above, if you chose “No” (the claimed invention does not meet the support requirement) or “both Yes and No,” please provide the reasons for your response, in the space below:

Case Study 4 on Hypothetical Case

Name of Office: JPO

Please fill in the examination results at your office on the following issues to be considered:

1. Does the invention of Claim 1 meet the clarity requirement?
 Yes
 No
 Both Yes and No
2. In Question 1 above, if you chose “Yes” (the claimed invention meets the clarity requirement) or “both Yes and No,” please provide the reasons for your response, in the space below:

Inventions claimed in patent applications shall be clear (Patent Act, Article 36 (6) (ii)). The statement in the claims has great significance, since the claims are used for the basis of determination on novelty and inventive step, etc., and also used for the basis of determination of the technical scope of a patented invention. Thus, it is necessary that an invention can be clearly identified from one claim. The requirement under Article 36 (6) (ii) is stated to ensure such necessity.

For a claimed invention to be clearly understood, it is necessary that the scope of the claimed invention shall be clear, that is to say, that the claims shall be stated such that a person skilled in the art can understand whether a specific product or process falls within the scope of the claimed invention, and to that end, the matter specifying the invention shall be clear. Also, since an invention for which a patent is sought is described on a claim-by-claim basis, one invention should be identified based on matters stated in one claim. (Examination Guidelines, Part II, Chapter 2, Section 3 “Clarity Requirement”, 2.1 “Basic ideas of determination of clarity requirement”).

Based on this, if a claim includes the expression of a function or characteristics, etc., there may be cases where, although the scope of the invention is clear, it is evident, even in light of the common general knowledge as of the filing, that a matter specified by the function or characteristics, etc. is not sufficiently specified from a technical perspective, and the claimed invention cannot be examined precisely on the patentability, such as novelty or inventive step, etc. based on the statement of the claim, even by considering the statements of the description and drawings. In such case, the function of the claims, which requires that an invention shall be clearly identified from one claim, is not secured, and therefore, the claim violates the clarity requirement. (Examination Guidelines, Part II, Chapter 2, Section 3 “Clarity Requirement”, 4. “Claims including Specific Expressions”)

Invention of Claim 1 contains statements that are designed to describe matters specifying the claimed invention by using the following functions and characteristics:
(1) “touch detection means (31) for determining whether or not a touch has occurred in a predetermined area where no keys of the keyboard layout (15) are displayed on the touch screen (12)”

(2) “keyboard changing means (33) for changing a keyboard layout displayed on the touch screen to another keyboard layout stored in the memory (34) when the touch detection means (31) determines that a touch has occurred in the predetermined area” Regarding (1), “touch detection means (31) for determining...” is considered to be means which persons skilled in the art can understand, by taking into account the statement of the claim and the common general knowledge of the invention in the art, as a means designed to determine that “a touch has occurred,” when “a touch has occurred in a predetermined area where no keys of the keyboard layout (15) are displayed on the touch screen (12).”

Therefore, what the description of “touch detection means (31) for determining...” exactly means can be clearly understood by persons skilled in the art.

Also, as supplementary comments, the description, which refers to the drawings, states how the touch detection unit 31 determines that a touch has occurred. That is, the determination is done when a touch has occurred by users with their fingers or by using a touch pen 20 in a predetermined area where no keys of the keyboard layout 15 are displayed on the touch screen 12, and then when such information is sent to the unit 31.

And, it has been found that a method for determining that a touch has occurred after such touch is: (i) to convert the information on the touch into a digital signal; (ii) to send this signal by a means, such as a voltage pulse; and (iii) based on the signal information, and by using general purpose programs stored in the unit, to determine that a touch has occurred. By taking into account the common general knowledge of the invention in the art, it is recognized that this method can be very generally adopted and would be sufficiently understood by persons skilled in the art.

Therefore, when considering the description and the drawings, in addition to the statement of the claim, the meaning of “touch detection means 31 for determining...” can be specifically understood by persons skilled in the art.

Regarding (2), “keyboard changing means (33) for changing...” is considered to be means which persons skilled in the art can understand, by taking into account the statement of the claim and the common general knowledge of the invention in the art. That is, the persons can understand this as a means designed to change the keyboard layout, i.e. “change a keyboard layout displayed on the touch screen to another keyboard layout stored in the memory,” when “the detection means (31) determines that a touch has occurred.”

Therefore, what the description of “keyboard changing means (33) for changing...” exactly means can be clearly understood by persons skilled in the art.

Also, as supplementary comments, the description, which refers to the drawings, states how the keyboard changing unit 33 changes the keyboard layout. That is, the change is conducted when: (i) the touch detection unit 31 determines that a touch has occurred; and (ii) the unit 31 sends a signal to the keyboard changing unit 33, which indicates that a touch has occurred. As a result, the unit 33 will change a keyboard layout displayed on the touch screen 12 to another keyboard layout image stored in the memory 34.

And, regarding the means for changing the keyboard layout displayed on a touch screen 12 to another keyboard layout stored in the memory 34, by taking into account the common general knowledge of the invention in the art, persons skilled in the art can sufficiently identify the very generally-adopted means such as (i) the unit 31 converts the detection information into a digital signal, which indicates that a touch has occurred; (ii) the unit 31 sends this signal by a means, such as a voltage pulse, to the unit 33; and (iii) based on the signal information, and by using general purpose programs stored in the device, the keyboard changing unit 33 obtains a layout from the keyboard layout stored in the memory 34; and (iv) the unit 33 changes a keyboard layout displayed on the touch screen 12 to the obtained keyboard layout.

Therefore, when considering the description and the drawings, in addition to the statement of the claim, the meaning of “keyboard changing means 33 for changing...” can be specifically understood by persons skilled in the art.

Based on the above, the claimed invention meets the clarity requirement.

3. In Question 1 above, if you chose “No” (the claimed invention does not meet the clarity requirement) or “both Yes and No,” please provide the reasons for your response, in the space below:
4. Does the invention of Claim 1 meet the support requirement?
 Yes
 No
 Both Yes and No
5. In Question 4 above, if you chose “Yes” (the claimed invention meets the support requirement) or “both Yes and No,” please provide the reasons for your response, in the space below:

A claimed invention shall be disclosed in the description (Patent Act, Article 36 (6) (i)). The purpose of this requirement (support requirement) is to prevent a patent from being granted for an invention which is not disclosed to the public. (Examination Guidelines, Part II, Chapter 2, Section 2 “Support Requirement”, 1. “Overview”)

The examiner examines a substantial correspondence between the claimed invention and the invention stated in the description to determine whether the support requirement is met. The consideration of the substantial correspondence done by the examiner is to examine whether or not the claimed invention exceeds “the extent of disclosure in the description to which a person skilled in the art would recognize that a problem to be solved by the invention would be actually solved.” (Examination Guidelines, Part II, Chapter 2, Section 2 “Support Requirement”, 2. “Determination of Support Requirement”)

It can be said that, based on the description, a problem to be solved by the claimed invention is related to handheld portable terminals, such as smartphones and tablets, and is to provide a character input device, easily enabling users to change one keyboard layout displayed on a touch screen to other keyboard layouts.

As a means to solve the above mentioned problem, the descriptions and the drawings contain the following means: a touch detection unit for determining whether or not a touch has occurred in a predetermined area of the touch screen; and a keyboard changing unit for changing a keyboard layout displayed on a touch screen to other keyboard layouts stored in the memory, when the touch detection unit sends a signal indicating that a touch has occurred. (See Figure 3 and the detailed explanations by using Figure 3 in the description)

In addition, by taking into account the common general knowledge of the invention in the art, which is referred to in 2 stated above, persons skilled in the art would recognize that the above mentioned problem can be solved by touch detection means, such as the above mentioned touch detection unit, and keyboard changing means, such as the above mentioned keyboard changing unit.

Also, Claim 1 of the invention recites the above mentioned means.

Based on the above, the invention of Claim 1 meets the support requirement.

6. In Question 4 above, if you chose “No” (the claimed invention does not meet the support requirement) or “both Yes and No,” please provide the reasons for your response, in the space below:

Case Study 4 on Hypothetical Case

Name of Office: KIPO

Please fill in the examination results at your office on the following issues to be considered:

1. Does the invention of Claim 1 meet the clarity requirement?

- Yes**
 No
 Both Yes and No

2. In Question 1 above, if you chose “Yes” (the claimed invention meets the clarity requirement) or “both Yes and No,” please provide the reasons for your response, in the space below:

If the person skilled in the art could understand the claimed subject-matter, taking into account a detailed description or drawing(s) and the background art as filed, it shall be determined, in principle, that the claimed invention is clearly and concisely established.

In case of the above claim, as the person skilled in the art could clearly understand the claimed subject-matter and the statement “means for...”, taking into account a detailed description or drawing(s), it can be determined that the concerned claim satisfies the requirement of Article 42(4)(ii) of the Patent Act of Korea.

3. In Question 1 above, if you chose “No” (the claimed invention does not meet the clarity requirement) or “both Yes and No,” please provide the reasons for your response, in the space below:

4. Does the invention of Claim 1 meet the support requirement?

- Yes**
 No
 Both Yes and No

5. In Question 4 above, if you chose “Yes” (the claimed invention meets the support requirement) or “both Yes and No,” please provide the reasons for your response, in the space below:

Whether the claim is supported by the description of the present invention is determined by whether a matter corresponding to the subject of the claim is stated in the description of the present invention, from the view point of the person skilled in the art. Rather than literal identical between the claims and the description of the invention, it should more closely be reviewed whether the claim refers to a subject which is beyond the scope of the description of the invention, from the perspective of the person skilled in the art.

In this case, it is obvious for a person skilled in the art that features written in the claim are supported by the statements of the description.

6. In Question 4 above, if you chose “No” (the claimed invention does not meet the support requirement) or “both Yes and No,” please provide the reasons for your response, in the space below:

Case Study 4 on Hypothetical Case

Name of Office: CNIPA

Please fill in the examination results at your office on the following issues to be considered:

1. Does the invention of Claim 1 meet the clarity requirement?

- Yes**
 No
 Both Yes and No

2. In Question 1 above, if you chose “Yes” (the claimed invention meets the clarity requirement) or “both Yes and No,” please provide the reasons for your response, in the space below:

The claims shall define the extent of the patent protection sought for in a clear and concise manner. (PATENT LAW OF THE PEOPLE’S REPUBLIC OF CHINA, Article 26.4)

The clarity of the claims is of the utmost importance for the determination of the extent for which protection is sought by an invention or utility model. The requirement that the claims shall be clear means, on the one hand, individual claims shall be clear, and on the other hand, the claims as a whole shall be clear as well.

A product claim is suitable for an invention or utility model of product, and shall usually be defined in terms of the structural features of the product. In particular cases, where one or more technical features in a product claim cannot be clearly expressed in terms of structural features, it is permissible to express them with the aid of physical or chemical parameters. Where the features cannot be clearly expressed in terms of either structural features or parameter features, it is permissible to express them with the aid of process features. When parameters are used for the expression, the parameters used must be those which can be clearly and reliably determined by a person skilled in the art according to the teachings of the description or by customary means of the relevant art.

(GUIDELINES FOR PATENT EXAMINATION, Part II, Chapter 2, Section 3 “The Claims”, 3.2.2 “Clarity”)

Usually, for product claims, features of function or effect shall be avoided as far as possible to be used in defining the invention. It is only when a certain technical feature cannot be defined by a structural feature, or it is more appropriate to be defined by a feature of function or effect than by a structural feature, and the function or effect can be directly and affirmatively verified by experiments or operations as stated in the description or by customary means in the art, that definition by features of function or effect in a product claim can be permissible.

Technical feature defined by function in a claim shall be construed as embracing all the means that are capable of performing the function. (GUIDELINES FOR PATENT EXAMINATION, Part II, Chapter 2, Section 3 “The Claims”, 3.2.1 “Support in the Description”)

Claim 1 contains functional definitions that are designed to define the technical features by the following functions and characteristics:

(1) “touch detection means (31) for determining whether or not a touch has occurred in a predetermined area where no keys of the keyboard layout (15) are displayed on the touch screen (12)”;

(2) “keyboard changing means (33) for changing a keyboard layout (15) displayed on the touch screen to another keyboard layout (15) stored in the memory (34) when the touch detection means (31) determines that a touch has occurred in the predetermined area”. Regarding (1), the technical feature of “touch detection means” defined by function in claim 1 shall be construed as embracing all the means that are capable of performing the function of “determining whether or not a touch has occurred in a predetermined area where no keys of the keyboard layout are displayed on the touch screen”. Therefore, by taking into account the statement of the claim and the common general knowledge in the art, what “touch detection means for determining...” exactly means can be clearly understood by persons skilled in the art.

Regarding (2), the technical feature of “keyboard changing means” defined by function in claim 1 shall be construed as embracing all the means that are capable of performing the function of “changing a keyboard layout displayed on the touch screen to another keyboard layout stored in the memory unit when the touch detection means determines that a touch has occurred in the predetermined area”. Therefore, by taking into account the statement of the claim and the common general knowledge in the art, what “keyboard changing means for changing...” exactly means can be clearly understood by persons skilled in the art.

Thus, claim 1 meets the clarity requirement.

3. In Question 1 above, if you chose “No” (the claimed invention does not meet the clarity requirement) or “both Yes and No,” please provide the reasons for your response, in the space below:

4. Does the invention of Claim 1 meet the support requirement?

- Yes**
- No**
- Both Yes and No**

5. In Question 4 above, if you chose “Yes” (the claimed invention meets the support requirement) or “both Yes and No,” please provide the reasons for your response, in the space below:

The claims shall be supported by the description. (PATENT LAW OF THE PEOPLE’S REPUBLIC OF CHINA, Article 26.4)

“The claims shall be supported by the description” means that the technical solution for which protection is sought in each of the claims shall be a solution that a person skilled in the art can reach directly or by generalization from the contents sufficiently disclosed in the description, and shall not go beyond the scope of the contents disclosed in the description. Claims are usually generalizations from one or more embodiments or examples as set forth in the description. The generalization of a claim shall not go beyond the scope of the contents disclosed in the description. If the person skilled in the art can reasonably predict that all the equivalents or obvious variants of the embodiments set forth in the description have the same properties or uses, then the applicant shall be allowed to generalize the protection extent of the claim to cover all the equivalents or obvious variants. In determining whether the generalization of a claim is appropriate, the examiner shall refer to the relevant prior art.

For claims generalized in generic terms or by parallel options, the examiner shall examine whether the generalization can be supported by the description. Where the generalization of a claim includes contents speculated by the applicant and the effect thereof is difficult to

determine or evaluate beforehand, the generalization shall be regarded as going beyond the scope of the contents disclosed in the description. If the generalization of a claim is such that the person skilled in the art can reasonably doubt that one or more specific terms or options included in the generic terms or parallel options cannot solve the technical problem aimed to be solved by the invention or utility model and achieve the same technical effects, then it shall be taken that the claim is not supported by the description. In these cases, the examiner shall raise an objection of lack of support on the ground of Article 26.4 and invite the applicant to amend the claim.

Usually, for product claims, features of function or effect shall be avoided as far as possible to be used in defining the invention. It is only when a certain technical feature cannot be defined by a structural feature, or it is more appropriate to be defined by a feature of function or effect than by a structural feature, and the function or effect can be directly and affirmatively verified by experiments or operations as stated in the description or by customary means in the art, that definition by features of function or effect in a product claim can be permissible.

Technical feature defined by function in a claim shall be construed as embracing all the means that are capable of performing the function. For claim containing a feature defined by function, whether the definition by function can be supported by the description shall be examined. If the function is carried out in a particular way in the embodiments of the description, and the person skilled in the art would not appreciate that the function could be carried out by other alternative means not described in the description, or the person skilled in the art can reasonably doubt that one or more means embraced in the definition by function cannot solve the technical problem aimed to be solved by the invention or utility model and achieve the same technical effect, then the definition by function as embracing the other alternative means or means incapable of solving the technical problem shall not be allowed in the claim. (GUIDELINES FOR PATENT EXAMINATION, Part II, Chapter 2, Section 3 “The Claims”, 3.2.1 “Support in the Description”)

Claim 1 contains functional definitions that are designed to define the technical features by the following functions and characteristics:

(1) “touch detection means (31) for determining whether or not a touch has occurred in a predetermined area where no keys of the keyboard layout (15) are displayed on the touch screen (12)”;

(2) “keyboard changing means (33) for changing a keyboard layout (15) displayed on the touch screen to another keyboard layout (15) stored in the memory (34) when the touch detection means (31) determines that a touch has occurred in the predetermined area”.

Based on the description, a problem to be solved by the claimed invention is related to portable terminals, such as smartphones and tablets, and is to provide a character input device, easily enabling users to change one keyboard layout image displayed on a touch screen to other keyboard layout images (See description, paragraph 1).

As a means to solve the above mentioned problem, the description and the drawings contain the following means: a touch detection unit for determining whether or not a touch by users has occurred in a predetermined area of the touch screen; and a keyboard changing unit for changing a keyboard layout displayed on a touch screen to another keyboard layout stored in the memory, when the touch detection unit sends a signal indicating that the touch has occurred. The description also discloses more specific operation steps performed by the touch detection unit and the keyboard changing unit (See description, paragraphs 7-9).

Based on the description and the common general knowledge in the art, the person skilled in the art can reasonably predict that all the equivalents or obvious variants of the embodiments set forth in the description have the same properties or uses. And, the

person skilled in the art can reasonably predict that definition by features of function in claim 1 does not embrace the means which is incapable of solving the technical problem aimed to be solved by the invention. Then the features (1) and (2) in claim 1 can be allowed.

Based on the above, definition by features of function in claim 1 is permissible, and thus claim 1 meets the support requirement.

6. In Question 4 above, if you chose “No” (the claimed invention does not meet the support requirement) or “both Yes and No,” please provide the reasons for your response, in the space below:

Case Study 4 on Hypothetical Case

Name of Office: USPTO

Please fill in the examination results at your office on the following issues to be considered:

1. Does the invention of Claim 1 meet the clarity requirement?

- Yes**
 No
 Both Yes and No

2. In Question 1 above, if you chose "Yes" (the claimed invention meets the clarity requirement) or "both Yes and No," please provide the reasons for your response, in the space below:

35 U.S.C. 112 (b) The specification shall conclude with one or more claims particularly pointing out and distinctly claiming the subject matter which the inventor or a joint inventor regards as the invention

35 U.S.C. 112 (f): An element in a claim for a combination may be expressed as a means or step for performing a specified function without the recital of structure, material, or acts in support thereof, and such claim shall be construed to cover the corresponding structure, material, or acts described in the specification and equivalents thereof.

Accordingly, examiners will apply **35 U.S.C. 112(f)** to a claim limitation if it meets the following 3-prong analysis: (A) the claim limitation uses the term "means" or "step" or a term used as a substitute for "means" that is a generic placeholder for performing the claimed function; (B) the term "means" or "step" or the generic placeholder is modified by functional language, typically, but not always linked by the transition word "for" (e.g., "means for") or another linking word or phrase, such as "configured to" or "so that"; and (C) the term "means" or "step" or the generic placeholder is not modified by sufficient structure, material, or acts for performing the claimed function. (MPEP 2181 I. DETERMINING WHETHER A CLAIM LIMITATION INVOKES 35 U.S.C. 112(f) or PRE-AIA 35 U.S.C. 112, SIXTH PARAGRAPH)

In claim 1, "touch detection means" and "keyboard changing means" are presumed to invoke 112(f) because they use the term "means", "means" is modified by functional language (determining...; changing...) linked by the transition word "for", and the term "means" is not modified by sufficient structure, material or acts for performing the claimed function. Therefore, they are construed to cover the corresponding structure described in the specification.

35 U.S.C. 112(f) states that a claim limitation expressed in means- (or step-) plus-function language "shall be construed to cover the corresponding structure...described in the specification and equivalents thereof." "If one employs means plus function language in a claim, one must set forth in the specification an adequate disclosure showing what is meant by that language. If an applicant fails to set forth an adequate disclosure, the applicant has in effect failed to particularly point out and distinctly claim the invention as required by the 35 U.S.C. 112(b)" In re Donaldson Co., 16 F.3d 1189, 1195, 29 USPQ2d 1845, 1850 (Fed. Cir. 1994) (en

banc). (MPEP 2181 II. DESCRIPTION NECESSARY TO SUPPORT A CLAIM LIMITATION WHICH INVOKES 35 U.S.C. 112(f) or Pre-AIA 35 U.S.C. 112, SIXTH PARAGRAPH)

Under certain limited circumstances, the written description does not have to explicitly describe the structure (or material or acts) corresponding to a means- (or step-) plus-function limitation to particularly point out and distinctly claim the invention as required by 35 U.S.C. 112(b) or pre-AIA 35 U.S.C. 112, second paragraph. See Dossel, 115 F.3d at 946, 42 USPQ2d at 1885...Further, disclosure of structure corresponding to a means-plus-function limitation may be implicit in the written description if it would have been clear to those skilled in the art what structure must perform the function recited in the means-plus-function limitation...Dossel, 115 F.3d at 946-47, 42 USPQ2d at 1885 ("Clearly, a unit which receives digital data, performs complex mathematical computations and outputs the results to a display must be implemented by or on a general or special purpose computer (although it is not clear why the written description does not simply state 'computer' or some equivalent phrase)."). (MPEP 2181 II. A. The Corresponding Structure Must Be Disclosed In the Specification Itself in a Way That One Skilled In the Art Will Understand What Structure Will Perform the Recited Function)

(A) In this case, the disclosure states:

Also, Smartphone 10 contains a CPU and a memory. The CPU is a processing unit that is used to execute programs stored in the memory. The CPU performs processing to control each part of Smartphone 10 and performs various functions described later. The memory stores programs and data to carry out the invention, and also acts as the working memory of the CPU. The following are detailed explanations shown in Figure 3 about the processing when Smartphone 10 is in the keyboard operating mode.

Though the drawings are block diagrams that do not show a specific structure for touch detection means (31) and keyboard changing means (33) and the disclosure does not explicitly state the claimed "means" are the CPU, it would have been clear to one of ordinary skill in the art, given the above excerpt from the disclosure, that a CPU performs the claimed functions.

To claim a means for performing a specific computer-implemented function and then to disclose only a general purpose computer as the structure designed to perform that function amounts to pure functional claiming... In this instance, the structure corresponding to a 35 U.S.C. 112(f) claim limitation for a computer-implemented function must include the algorithm needed to transform the general purpose computer or microprocessor disclosed in the specification (MPEP 2181 II. B. Computer-Implemented Means-Plus-Function Limitations)

If the specification explicitly discloses an algorithm, the sufficiency of the disclosure of the algorithm must be determined in light of the level of ordinary skill in the art...The examiner should determine whether one skilled in the art would know how to program the computer to perform the necessary steps described in the specification (i.e., the invention is enabled), and that the inventor was in possession of the invention (i.e., the invention meets the written description requirement). Thus, the specification must sufficiently disclose an algorithm to transform a general purpose microprocessor to a special purpose computer so that a person of ordinary skill in the art can implement the disclosed algorithm to achieve the claimed function. Aristocrat, 521 F.3d at 1338, 86 USPQ2d at 1242 (MPEP 2181 II. B. Computer-Implemented Means-Plus-Function Limitations)

(B) The steps described in the specification for touch detection means:
A touch detection unit 31 determines whether or not a touch by users has occurred in a predetermined area of the touch screen 12. Users can touch a touch screen 12 with their fingers or by using a touch pen 20. The above mentioned predetermined area is an area where no keys of the keyboard layout 15 are displayed on the touch screen 12. This area is indicated with diagonal lines in Figure 2.

(C) The steps described in the specification for keyboard changing unit:
When the touch detection unit 31 sends a signal indicating that a touch has occurred in the predetermined area, unit 33 changes the keyboard layout 15 currently being displayed on the touch screen to another keyboard layout stored in the memory 34.
The following are more specific descriptions on the above mentioned control conducted by the keyboard changing unit 33. The memory 34 stores three types of keyboard layouts in the following order: "capital-letter alphabetic characters keyboard layout," "small-letter alphabetic characters keyboard layout," and "ten-key numerical characters keyboard layout." For example, in cases where a "capital-letter alphabetic keyboard layout" is displayed on the touch screen, if a signal that a touch has occurred is sent to the keyboard changing unit 33, the keyboard changing unit 33 will change the keyboard layout being displayed on the touch screen to either of the two other keyboard layouts, i.e. a "ten-key numerical characters keyboard layout" or a "small-letter alphabetic characters keyboard layout", stored next to this current keyboard layout in the memory 34.

One skilled in the art would know how to program a processor to perform the necessary steps described above. There is sufficient description of how to transform the general-purpose CPU into a special-purpose CPU to perform the claimed functions.

3. In Question 1 above, if you chose "No" (the claimed invention does not meet the clarity requirement) or "both Yes and No," please provide the reasons for your response, in the space below:

4. Does the invention of Claim 1 meet the support requirement?

Yes

No

Both Yes and No

5. In Question 4 above, if you chose "Yes" (the claimed invention meets the support requirement) or "both Yes and No," please provide the reasons for your response, in the space below:

35 U.S.C. 112(a): The specification shall contain a written description of the invention, and of the manner and process of making and using it, in such full, clear, concise, and exact terms as to enable any person skilled in the art to which it pertains, or with which it is most nearly connected, to make and use the same, and shall set forth the best mode contemplated by the inventor or joint inventor of carrying out the invention

When examining computer-implemented functional claims, examiners should determine whether the specification discloses the computer and the algorithm (e.g., the necessary steps and/or flowcharts) that perform the claimed function in sufficient detail such that one of ordinary skill in the art can reasonably conclude that the inventor invented the claimed subject matter. (MPEP 2161.01 I. DETERMINING WHETHER THERE IS ADEQUATE

WRITTEN DESCRIPTION FOR A COMPUTER-IMPLEMENTED FUNCTIONAL CLAIM LIMITATION).

"As a general rule, where software constitutes part of a best mode of carrying out an invention, description of such a best mode is satisfied by a disclosure of the functions of the software. This is because, normally, writing code for such software is within the skill of the art, not requiring undue experimentation, once its functions have been disclosed. . . . [F]low charts or source code listings are not a requirement for adequately disclosing the functions of software." *Fonar Corp.*, 107 F.3d at 1549, 41 USPQ2d at 1805 (citations omitted). (MPEP 2161.01 II BEST MODE)

To satisfy the enablement requirement of 35 U.S.C. 112(a) or pre-AIA 35 U.S.C. 112, first paragraph, the specification must teach those skilled in the art how to make and use the full scope of the claimed invention without "undue experimentation." (MPEP 2161.01 III. DETERMINING WHETHER THE FULL SCOPE OF A COMPUTER-IMPLEMENTED FUNCTIONAL CLAIM LIMITATION IS ENABLED)

Given the above cited portions of the disclosure (A), (B), and (C) from the previous question, one of ordinary skill in the art would be able to make and use the invention, e.g. by programming a computer to perform the claimed functions. The description clearly sets forth the invention to enable users to easily change the keyboard layout displayed on a touchscreen of a device, where the best mode is to detect a touch on an area where no keys of a keyboard layout are displayed.

6. In Question 4 above, if you chose "No" (the claimed invention does not meet the support requirement) or "both Yes and No," please provide the reasons for your response, in the space below:

2. Case 5

(1) Hypothetical Case

Case 5

[Claims]

1. A method for approximating the amount of net coulomb charge charged/discharged in a rechargeable battery, the method comprising the steps of:
calculating the zero-current state potential (V_{zero}) from the potential across the terminals of the rechargeable battery when a selected current condition or a selected voltage condition is maintained for a predetermined period of time during the use of such rechargeable battery; and
calculating the net coulomb charge charged/discharged (ΔQ_{ap}) of the rechargeable battery based on the amount of change (ΔV_{zero}) of the said zero-current state voltage (V_{zero}).

[Description]

In the past, the amount of net coulomb charge charged/discharged in a rechargeable battery was obtained by measuring the current charged/discharged amount from the rechargeable battery and making an approximation based on the integrated value of the measured current. However, as the amount is approximation based on the integrated value of the measured current, there was a problem with the approximation accuracy, as it tended to decrease due to the accumulated measurement errors of the current.

The problem to be solved by the present invention is to reduce the influence of measurement errors of the current and in approximating the charged/discharged amount of net coulomb charge, and to approximate the amount of net coulomb charge charged/discharged in a rechargeable battery more accurately.

The present invention relates to a method for approximating the amount of net coulomb charge charged/discharged in a rechargeable battery. As an approximation method for solving the above-mentioned problem, the method comprising the steps of calculating the zero-current state potential (V_{zero}) from the potential across the terminals of the rechargeable battery when a selected current condition or a selected voltage condition is maintained for a predetermined period of time during the use of such rechargeable battery; and calculating the approximate net coulomb charge charged/discharged (ΔQ_{ap}) of the rechargeable battery based on the amount of change (ΔV_{zero}) of the said zero-current state potential (V_{zero}).

In this invention, the current terminal potential of the rechargeable battery are constantly measured at first. Then, the condition in which the measured current or the measured potential sustain a selected current condition or a selected voltage condition for a predetermined period of time is considered as a condition in which the said current and voltage have continuously stabilized for a determined period of time. Based on the average amount of the potential and current measured during the predetermined period of time and the component resistance of the rechargeable battery, the voltage of the rechargeable battery when current is not flowing, that is, the potential at zero-current state and the amount of its change are calculated.

Furthermore, based on the correlation between the amount of change of the current and the amount of net coulomb charge charged/discharged (the closer to full charge, the smaller the temporal change), and using the coefficient determined as appropriate based on the measured data for the amount of change of the potential at zero-current state and the amount of net coulomb charge charged/discharged, and the one-dimensional

approximation function, the method approximates the amount of net coulomb charge charged/discharged from the calculated amount of change for the potential at zero-current state that was previously calculated.

More specifically, an example in which the conditions are “the current is less than 10A” for the said selected current condition, “the amount of change for the potential is less than 1V” for the said selected voltage condition, and the said predetermined period of time is set at “10 seconds,” and consider the current condition (less than 10A) or the voltage condition (the amount of change is less than 1V) set is maintained for the said predetermined period of time (10 seconds) as the condition in which the current and voltage in a rechargeable battery is continuously stabilized for a determined period of time. Then, the zero-current state potential (V_{zero}) is calculated by adding a value obtained by multiplying the average amount of voltage (I_{ave}) measured within the certain period of time by the component resistance (R_{com}) to an average value (V_{ave}) measured within the predetermined period of time (amending the voltage drop due to component resistance) ($V_{zero} = V_{ave} + R_{com} \times I_{ave}$).

For example, by using the following formula decided on based on the measured data as the approximation function of the amount of change of the zero-current state potential and the amount of net coulomb charge charged/discharged for the rechargeable battery that is the object of measurement, the approximation of the amount of net coulomb charge charged/discharged (ΔQ_{ap}) in a rechargeable battery is calculated from the amount of change of the zero-current state potential (ΔV_{zero}) calculated before.

$\Delta Q_{ap} = \kappa \times \Delta V_{zero} + \delta$ (κ and δ : Constants set in advance based on the measured data)

As the present invention approximates the amount of net coulomb charge charged/discharged ΔQ_{ap} based on the function formula using the zero-current state voltage that is less influenced by measurement errors of the current, it has an effect of accurately approximating the amount of net coulomb charge charged/discharged in a rechargeable battery.

Issues to be Considered

- (a) Is the invention of Claim 1 unclear because of the statement “selected current condition or voltage condition”?
- (b) Is the invention of Claim 1 is unclear because of the statement “calculating the approximate amount of net coulomb charge charged/discharged (ΔQ_{ap}) of the rechargeable battery based on the amount of change (ΔV_{zero}) of the said zero-current state potential voltage (V_{zero})”?
- Does the invention of Claim 1 meet the support requirement?

2. Case 5

(2) Case Study by IP5 Offices

Case Study 5 on Hypothetical Case

Name of Office: EPO

Please fill in the examination results at your office on the following issues to be considered:

1. Does the invention of Claim 1 meet the clarity requirement?

- Yes**
 No
 Both Yes and No

2. In Question 1 above, if you chose “Yes” (the claimed invention meets the clarity requirement) or “Both Yes and No,” please provide the reasons for your response in the space below.

3. In Question 1 above, if you chose “No” (the claimed invention does not meet the clarity requirement) or “both Yes and No,” please provide the reasons for your response, in the space below:

With respect to point a) the selected condition can be understood in the light of the description, but the examiner may question how the “selection” is being performed, which does not appear to be taught in the application as such, i.e. in what range is the test operating? In addition, the term “approximating” is very vague, and the skilled person will not know how close an approximation, and in which range he is operating.

The wording: “selected current condition or selected voltage condition” can be understood by a skilled person of the field of batteries so that the wording can be considered clear as such. However with respect to novelty, this allows a large variety of conditions if found in the prior art to be used against the feature.

Said wording is very general and is also included in a very general method step. This may lead to an objection from the EPO examiner under Article 84 EPC.

The concerned method step is reproduced here below:

“calculating the zero-current state potential (V_{zero}) from the potential across the terminals of the rechargeable battery when a selected current condition or a selected voltage condition is maintained for a predetermined period of time during the use of such rechargeable battery”.

When assessing the clarity of such a broad method step the EPO examiner normally applies the instructions given in the EPO Guidelines in particular in sections F-IV 4.5.3 “Generalization of essential features” and F-IV 4.10 “Result to be achieved”. These instructions are derived from the European case law and applied and linked to the requirements of Article 84 EPC (Article 84 EPC reads: “The claims shall define the matter for which protection is sought. They shall be clear and concise and be supported by the description”).

The concerned method step is a generalization of a methodology described in the description on page 4 last line to page 5, first paragraph (corresponds to fourth paragraph): “In this invention, the current terminal potential of the rechargeable battery are constantly

measured at first. Then, the condition in which the measured current or the measured potential sustain a selected current condition or a selected voltage condition for a predetermined period of time is considered as a condition in which the said current and voltage have continuously stabilized for a predetermined period of time. Based on the average amount of the potential and current measured during the predetermined period of time and the component resistance of the rechargeable battery, the voltage of the rechargeable battery when current is not flowing, that is, the potential at zero-current state and the amount of its change is calculated.” and furthermore based on the specific example of the third paragraph on page 5 (corresponds to sixth paragraph) of the description:

“More specifically, an example in which the conditions are “the current is less than 10A” for the said selected current condition, “the amount of change for the voltage is less than 1V” for the said selected voltage condition, and the said predetermined period of time is set at “10 seconds,” and consider the current condition (less than 10A) or the voltage condition (the amount of change is less than 1V) set is continuously satisfied for the said predetermined period of time (10 seconds) as the condition in which the current and voltage in a rechargeable battery is continuously stabilized for a predetermined period of time. Then, the zero-current state voltage (V_{zero}) is calculated by adding a value obtained by multiplying the average amount of voltage (I_{ave}) measured within the predetermined period of time by the component resistance (R_{com}) to an average value (V_{ave}) measured within the predetermined period of time (amending the voltage drop due to component resistance) ($V_{zero} = V_{ave} + R_{com} \times I_{ave}$).”

Regarding the first aspect of “Generalization of essential features” EPO Guidelines set as a condition: “it is sufficient if the application as a whole describes the necessary characteristics of an invention in a degree of detail such that a person skilled in the art can perform the invention It is not necessary to include all details of the invention in the independent claim. Thus a certain degree of generalization of the claimed features may be permitted, provided that the claimed generalized features as a whole allow the problem to be solved. In this case a more specific definition of the features is not required. ...”

In the present case the method step specifies in general terms the essential feature of how the zero-current state voltage is calculated. No objection is raised as to an excessive degree of generalization of the method step.

However, a second check is performed by EPO examiner which is related to the aspect of: Is the invention defined in terms of a result to be achieved? More specifically the following instructions are given to EPO examiners (Guidelines section F-IV 4.10):

“The area defined by the invention must be as precise as the invention allows. As a general rule, claims which attempt to define the invention by a result to be achieved are not allowed,... . However, they may be allowed if the invention either can only be defined in such terms or cannot otherwise be defined more precisely without unduly restricting the scope of the claims and if the result is one which can be directly and positively verified by tests or procedures adequately specified in the description or known to the person skilled in the art and which do not require undue experimentation”.

In the present case the EPO examiner would appreciate that in view of the description a more precise definition of the invention is possible without unduly restricting the scope of protection.

In particular the expression “a selected current condition or a selected voltage condition for a predetermined period of time” is considered as a condition in which the said current and voltage have continuously stabilized for a predetermined period of time. Therefore the EPO examiner would likely suggest the addition of this definition (shown by underlining) in the claim to clarify the method step.

Furthermore, the EPO examiner would likely consider that the method step does not clearly indicate how the zero-current state voltage is calculated and would possibly require the applicant to specify the actual equation provided in the description in the claim itself.

(b) With respect to point b), the claim defines “calculating the zero-current state voltage” but does not say that this step is repeated at a later time. As a result, an “amount of change of the said zero-current state voltage” is not clear, a single calculation does not allow to determine a change, as the reference point is not defined.

In particular, in the phrase:

“calculating the net coulomb charge charged/discharged (ΔQ_{ap}) of the rechargeable battery based on the amount of change (ΔV_{zero}) of the said zero-current state voltage (V_{zero})”.

The EPO examiner would consider that the step is defined in terms of result to be achieved. This type of definition raises the question: is the scope of the claim sufficiently clear?

It is believed that the way the calculation is done in the description ($\Delta Q_{ap} = \kappa \times \Delta V_{zero} + \delta$ (κ and δ : Constants set in advance based on the measured data) is not straightforwardly clear to the skilled person. The skilled person reading the claim would wonder how the calculation is done – what data should be measured so the constants can be set in advance? The equation mentioned here above is further presented as an essential feature to solve the problem to be solved by the invention (accurately approximating the net coulomb charge charged/discharged in a rechargeable battery). As a conclusion, the second feature would therefore be considered as lacking clarity.

4. Does the invention of Claim 1 meet the support requirement?

- Yes**
- No**
- Both Yes and No**

5. In Question 4 above, if you chose “Yes” (the claimed invention meets the support requirement) or “both Yes and No,” please provide the reasons for your response, in the space below:

The description puts the skilled person reading the claims and the description in the position to perform the invention using his general knowledge without undue burden.

In this present case passages supporting all the claimed features in the sense of Article 84 EPC (claims shall be clear and supported by the description) can be found for all the claimed features. In the following the text of the claim and corresponding passages in the description are indicated in bold characters.

1. **A method for approximating the net coulomb charge charged/discharged in a rechargeable battery** (support in the description: page 4, second paragraph from bottom (corresponds to third paragraph): “**approximating the net coulomb charge charged/discharged in a rechargeable battery**”), the method comprising the steps of:

calculating the zero-current state voltage (V_{zero}) from the terminal voltage of the rechargeable battery (support from the description: page 5, second paragraph from bottom (corresponds to sixth paragraph), last sentence: “**Then, the zero-current state voltage (V_{zero}) is calculated...**” when a selected current condition or a selected voltage condition is continuously satisfied for a predetermined period of time during the use of such rechargeable battery (support in the description: page 5, first paragraph (corresponds to fourth paragraph): “**Then, the condition in which the current or the voltage measured continuously satisfy a selected current condition or a selected voltage condition for a predetermined period of time is considered as a condition in which the said current and voltage have continuously stabilized for a predetermined period of time...**”; and

calculating the net coulomb charge charged/discharged (ΔQ_{ap}) of the rechargeable battery based on the amount of change (ΔV_{zero}) of the said zero-current state voltage (V_{zero}) (support in the description: page 5 last paragraph to bottom of page 6 (corresponds to seventh paragraph): “**the estimation of the net coulomb charge charged/discharged (ΔQ_{ap}) in a rechargeable battery is calculated from the amount of change of the zero-current state voltage (ΔV_{zero}) calculated before. $\Delta Q_{ap} = \kappa \times \Delta V_{zero} + \delta$ (κ and δ : Constants set in advance based on the measured data)**”).)

6. In Question 4 above, if you chose “No” (the claimed invention does not meet the support requirement) or “both Yes and No,” please provide the reasons for your response, in the space below:

Case Study 5 on Hypothetical Case

Name of Office: JPO

Please fill in the examination results at your office on the following issues to be considered:

1. Does the invention of Claim 1 meet the clarity requirement?

- Yes**
 No
 Both Yes and No

2. In Question 1 above, if you chose “Yes” (the claimed invention meets the clarity requirement) or “Both Yes and No,” please provide the reasons for your response in the space below.

As referred to in above Case Study 4, inventions claimed in patent applications shall be clear (Patent Act, Article 36 (6) (ii)). For a claimed invention to be clearly understood, it is necessary that the scope of the claimed invention shall be clear, that is to say, that the claims shall be stated such that a person skilled in the art can understand whether a specific product or process falls within the scope of the claimed invention, and to that end, the matter specifying the invention shall be clear. (Examination Guidelines, Part II, Chapter 2, Section 3 “Clarity Requirement”, 2.1 “Basic ideas of determination of clarity requirement”).

In Claim 1 of the present invention, the following statement is explicitly stated:

- (a) “selected current condition or voltage condition”
(b) “calculating the approximate amount of net coulomb charge charged/discharged (ΔQ_{ap}) of the rechargeable battery based on the amount of change (ΔV_{zero}) of the said zero-current state voltage (V_{zero})”

Regarding (a), from the statement in the claim “calculating the zero-current state potential (V_{zero}) across the terminals of the rechargeable battery when a selected current condition or a selected voltage condition is maintained for a predetermined period of time during the use of such rechargeable battery”, persons skilled in the art can understand that the above statement “a selected current condition or a selected voltage condition” means an arbitrary current condition or voltage condition that is set as required as a condition for calculating the zero-current state potential (V_{zero}) in a rechargeable battery.

Therefore, the meaning of “a selected current condition or a selected voltage condition” is clear to persons skilled in the art.

Also, as supplementary comments, the description states in regard to the above “a selected current condition or a selected condition,” “the current terminal potential of the rechargeable battery are constantly measured at first. Then, the condition in which the measured current or the measured potential sustain a selected current condition or a selected voltage condition for a predetermined period of time is considered as a condition in which the said current and voltage have continuously stabilized for a determined period of time. Based on the average amount of the potential and current

measured during the predetermined period of time and the component resistance of the rechargeable battery, the voltage of the rechargeable battery when current is not flowing, that is, the potential at zero-current state and the amount of its change are calculated.” That is, the description states that the condition in which the above “a selected current condition or a selected voltage condition” is maintained for a certain period of time is considered as a condition in which the current and the voltage is continuously stabilized for a determined period of time.

Therefore, when considering the description, in addition to the statement of the claim, the meaning of the above: “a selected current condition or a selected voltage condition” can be specifically understood by persons skilled in the art.

Regarding (b), it is apparent that the “zero-current state potential (V_{zero})” means the potential when the current is zero (not flowing). Furthermore, persons skilled in the art can understand that “calculating the net coulomb charge charged/discharged (ΔQ_{ap}) of the rechargeable battery based on the amount of change (ΔV_{zero}) of the said zero-current state voltage (V_{zero})” means calculating ΔQ_{ap} from ΔV_{zero} , using the function for the amount of change of the zero-current state potential (ΔV_{zero}) and the net coulomb charge charged/discharged, based on the common general knowledge that the charged/discharged net coulomb charge correlates with the amount of change of potential for rechargeable batteries, as well as the common general knowledge that in general, the correlation between variables that correlate with each other can be expressed as appropriate through approximation that has a coefficient previously determined based on known data.

Therefore, the meaning of “calculating the net coulomb charge charged/discharged (ΔQ_{ap}) of the rechargeable battery based on the amount of change (ΔV_{zero}) of the said zero-current state voltage (V_{zero})” is apparent to persons skilled in the art.

Also, as supplementary comments, the description in regard to the “zero-current state potential (V_{zero})” states that “the voltage of a rechargeable battery when current is not flowing, that is the zero-current state potential” and “the zero-current state potential (V_{zero}) is calculated by adding a value obtained by multiplying the average amount of voltage (I_{ave}) measured within the certain period of time by the component resistance (R_{com}) to an average value (V_{ave}) measured within the predetermined period of time (amending the voltage drop due to component resistance) ($V_{zero} = V_{ave} + R_{com} \times I_{ave}$).”

Furthermore, it is also stated in the description regarding the above statement “calculating the net coulomb charge charged/discharged (ΔQ_{ap}) of the rechargeable battery based on the amount of change (ΔV_{zero}) of the said zero-current state voltage (V_{zero})” that: “based on the correlation between the amount of change of the current and the amount of net coulomb charge charged/discharged (the closer to full charge, the smaller the temporal change), and using the coefficient determined as appropriate based on the measured data for the amount of change of the potential at zero-current state and the amount of net coulomb charge charged/discharged, and the one-dimensional approximation function, the method approximates the amount of net coulomb charge charged/discharged from the calculated amount of change for the potential at zero-current state that was previously calculated.”; and “For example, by using the following formula decided on based on the measured data as the

approximation function of the amount of change of the zero-current state potential and the amount of net coulomb charge charged/discharged for the rechargeable battery that is the object of measurement, the approximation of the amount of net coulomb charge charged/discharged (ΔQ_{ap}) in a rechargeable battery is calculated from the amount of change of the zero-current state potential (ΔV_{zero}) calculated before. $\Delta Q_{ap} = \kappa \times \Delta V_{zero} + \delta$ (κ and δ : Constants set in advance based on the measured data)."

Based on this, it can be said that the description states that: "the zero-current state potential (V_{zero})" is the potential of the rechargeable battery when current is not flowing and is calculated by using a formula $V_{zero} = V_{ave} + R_{com} \times I_{ave}$ (V_{ave} : the average amount of voltage, I_{ave} : the average amount of current, R_{com} : the component resistance of the rechargeable battery; and that the net coulomb charge charged/discharged (ΔQ_{ap}) from the amount of change of the zero-current state potential (ΔV_{zero}) can be calculated by using a direct function, $\Delta Q_{ap} = \kappa \times \Delta V_{zero} + \delta$ (κ and δ : Constants set in advance based on the measured data).

Therefore, when considering the description, in addition to the statement of the claim, the meaning of the above statement: "calculating the net coulomb charge charged/discharged (ΔQ_{ap}) of the rechargeable battery based on the amount of change (ΔV_{zero}) of the said zero-current state voltage (V_{zero})" can be specifically understood by persons skilled in the art.

Based on the above, the claimed invention is clear.

3. In Question 1 above, if you chose "No" (the claimed invention does not meet the clarity requirement) or "both Yes and No," please provide the reasons for your response, in the space below:
4. Does the invention of Claim 1 meet the support requirement?
 Yes
 No
 Both Yes and No
5. In Question 4 above, if you chose "Yes" (the claimed invention meets the support requirement) or "both Yes and No," please provide the reasons for your response, in the space below:

As mentioned in the above Case Study 4, a claimed invention shall be disclosed in the description (Patent Act, Article 36 (6) (i)). The examiner examines a substantial correspondence between the claimed invention and the invention stated in the description. The consideration of the substantial correspondence done by the examiner is to examine whether or not the claimed invention exceeds "the extent of disclosure in the description to which a person skilled in the art would recognize that a problem to be solved by the invention would be actually solved." (Examination Guidelines, Part II, Chapter 2, Section 2 "Support Requirement", 2. "Determination of Support Requirement")

Here, it can be said that, based on the description, the problem to be solved by the claimed invention is to reduce the influence of measurement errors of the current and

in approximating the charged/discharged amount of net coulomb charge, and to approximate the amount of net coulomb charge charged/discharged in a rechargeable battery more accurately.

Also, the description includes: “the current terminal potential of the rechargeable battery are constantly measured at first. Then, the condition in which the measured current or the measured potential sustain a selected current condition or a selected voltage condition for a predetermined period of time is considered as a condition in which the said current and voltage have continuously stabilized for a determined period of time. Based on the average amount of the potential and current measured during the predetermined period of time and the component resistance of the rechargeable battery, the voltage of the rechargeable battery when current is not flowing, that is, the potential at zero-current state and the amount of its change are calculated.”; and “As the present invention approximates the amount of net coulomb charge charged/discharged ΔQ_{ap} based on the function formula using the zero-current state voltage that is less influenced by measurement errors of the current, it has an effect of accurately approximating the amount of net coulomb charge charged/discharged in a rechargeable battery.”

Based on this, by taking into account the common general knowledge of the invention in the art, which is referred to in 2 stated above, persons skilled in the art are able to recognize that the above mentioned issue can be solved by a method for approximating the amount of net coulomb charge charged/discharged in a rechargeable battery by calculating the zero-current state potential that is less influenced by measurement errors of the current and based on the amount of change of the said potential at zero-current state, when a selected current condition or a selected voltage condition is maintained for a predetermined period of time during the use of the rechargeable battery.

Also, Claim 1 of the invention contains the above mentioned means.

Based on the above, the invention of Claim 1 meets the support requirement.

6. In Question 4 above, if you chose “No” (the claimed invention does not meet the support requirement) or “both Yes and No,” please provide the reasons for your response, in the space below:

Case Study 5 on Hypothetical Case

Name of Office: KIPO

Please fill in the examination results at your office on the following issues to be considered:

1. Does the invention of Claim 1 meet the clarity requirement?

- Yes**
 No
 Both Yes and No

2. In Question 1 above, if you chose “Yes” (the claimed invention meets the clarity requirement) or “Both Yes and No,” please provide the reasons for your response in the space below.

a) As a selected current or a selected voltage is determined based on the property of the rechargeable battery, it can be determined that the current or the voltage is sufficiently specified based on the terminology itself.

b) Even though additional explanation has not been made, the person skilled in the art may clearly understand that the ‘zero-current state’ means the current, which flows outside the rechargeable battery, is valued as zero, and that the zero-current state has occurred because voltage has been dropped due to the loss of electricity resulted from inward current caused by inward resistance of the rechargeable battery. Further, the above matter is sufficiently implied in the detailed description of the claimed invention.

Therefore, it can be determined that the scope of the claim as above mentioned is clear pursuant to Article 42(4)(ii) of the Patent Act of Korea.

3. In Question 1 above, if you chose “No” (the claimed invention does not meet the clarity requirement) or “both Yes and No,” please provide the reasons for your response, in the space below:

4. Does the invention of Claim 1 meet the support requirement?

- Yes**
 No
 Both Yes and No

5. In Question 4 above, if you chose “Yes” (the claimed invention meets the support requirement) or “both Yes and No,” please provide the reasons for your response, in the space below:

Whether the claim is supported by the description of the present invention is determined by whether a matter corresponding to the subject of the claim is stated in the description of the present invention, from the view point of the person skilled in the art. Rather than literal identical between the claims and the description of the invention, it should more closely be reviewed whether the claim refers to a subject which is beyond the scope of the description of the invention, from the perspective of the person skilled in the art.

In this case, it is obvious for a person skilled in the art that features written in the claim are supported by the statements of the description.

6. In Question 4 above, if you chose “No” (the claimed invention does not meet the support requirement) or “both Yes and No,” please provide the reasons for your response, in the space below:

Case Study 5 on Hypothetical Case

Name of Office: CNIPA

Please fill in the examination results at your office on the following issues to be considered:

1. Does the invention of Claim 1 meet the clarity requirement?

- Yes**
 No
 Both Yes and No

2. In Question 1 above, if you chose “Yes” (the claimed invention meets the clarity requirement) or “Both Yes and No,” please provide the reasons for your response in the space below.

3. In Question 1 above, if you chose “No” (the claimed invention does not meet the clarity requirement) or “both Yes and No,” please provide the reasons for your response, in the space below:

The claims shall define the extent of the patent protection sought for in a clear and concise manner. (PATENT LAW OF THE PEOPLE’S REPUBLIC OF CHINA, Article 26.4)

The clarity of the claims is of the utmost importance for the determination of the extent for which protection is sought by an invention or utility model. The requirement that the claims shall be clear means, on the one hand, individual claims shall be clear, and on the other hand, the claims as a whole shall be clear as well.

A process claim is suitable for an invention of process, and shall usually be defined in terms of such technical features as technological process, operational conditions, steps, and procedures.

The extent of protection as defined by each claim shall be clear. The extent of protection of a claim shall be construed according to the meaning of the words used in the claim.

Generally, the words used in a claim shall be understood as having the meaning that they normally have in the relevant art. (GUIDELINES FOR PATENT EXAMINATION, Part II, Chapter 2, Section 3 “The Claims”, 3.2.2 “Clarity”)

In Claim 1, the following features are explicitly recited:

- (a) “a selected current condition or voltage condition”
(b) “calculating the net coulomb charge charged/discharged (ΔQ_{ap}) of the rechargeable battery based on the amount of change (ΔV_{zero}) of the said zero-current state voltage (V_{zero})”.

Regarding (a), as not been further defined, the technical feature of “a selected current condition or voltage condition” is ambiguous. The person skilled in the art cannot determine which current condition or voltage condition the feature “a selected current condition or a specific voltage condition” is intended to define. The person skilled in the art cannot distinguish between the extent of the selected current condition or voltage condition and the extent of other current conditions or voltage conditions which are not selected. Therefore, from the feature “*calculating the zero-current state potential (V_{zero}) from the potential across the terminals of the rechargeable battery when a selected current condition or a selected voltage condition is maintained for a predetermined period of time during the use of such rechargeable battery*” in claim 1, the person skilled in the art cannot

clearly determine the condition under which the zero-current state potential (V_{zero}) shall be calculated from the potential across the terminals of the rechargeable battery.

Furthermore, according to the description, the technical feature related to the condition under which the zero-current state potential (V_{zero}) shall be calculated from the potential across the terminals of the rechargeable battery is essential for solving the technical problem to be solved by the invention.

Therefore, the feature “selected current condition or voltage condition” makes the extent of protection in claim 1 unclear.

Regarding (b), it is apparent that “the zero-current state voltage (V_{zero})”, “the net coulomb charge charged/discharged (ΔQ_{ap})”, and “the change (ΔV_{zero}) of the said zero-current state voltage (V_{zero})” have the meanings that they normally have in the relevant art.

The person skilled in the art can understand that “calculating the net coulomb charge charged/discharged (ΔQ_{ap}) of the rechargeable battery based on the amount of change (ΔV_{zero}) of the said zero-current state voltage (V_{zero})” means calculating ΔQ_e from ΔV_{zero} by using any method or formula well known in the prior art.

Therefore, the meaning of “calculating the net coulomb charge charged/discharged (ΔQ_{ap}) of the rechargeable battery based on the amount of change (ΔV_{zero}) of the said zero-current state voltage (V_{zero})” is apparent to persons skilled in the art. The feature (b) in claim 1 is permissible.

To sum up, because the feature (a) makes the extent of protection in claim 1 unclear, claim 1 does not meet the clarity requirement.

4. Does the invention of Claim 1 meet the support requirement?

Yes, If the above mentioned defect has been overcome by adding to claim 1 the technical feature related to the condition disclosed in the description, such as “the condition in which the measured current or the measured potential sustain a selected current condition or a selected voltage condition for a predetermined period of time being a condition in which the said current and voltage have continuously stabilized for a determined period of time”.

No

Both Yes and No

5. In Question 4 above, if you chose “Yes” (the claimed invention meets the support requirement) or “both Yes and No,” please provide the reasons for your response, in the space below:

The claims shall be supported by the description. (PATENT LAW OF THE PEOPLE'S REPUBLIC OF CHINA, Article 26.4)

“The claims shall be supported by the description” means that the technical solution for which protection is sought in each of the claims shall be a solution that a person skilled in the art can reach directly or by generalization from the contents sufficiently disclosed in the description, and shall not go beyond the scope of the contents disclosed in the description. Claims are usually generalizations from one or more embodiments or examples as set forth in the description. The generalization of a claim shall not go beyond the scope of the contents disclosed in the description. If the person skilled in the art can reasonably predict that all the equivalents or obvious variants of the embodiments set forth in the description have the same properties or uses, then the applicant shall be allowed to generalize the protection extent of the claim to cover all the equivalents or obvious variants. In

determining whether the generalization of a claim is appropriate, the examiner shall refer to the relevant prior art.

For claims generalized in generic terms or by parallel options, the examiner shall examine whether the generalization can be supported by the description. Where the generalization of a claim includes contents speculated by the applicant and the effect thereof is difficult to determine or evaluate beforehand, the generalization shall be regarded as going beyond the scope of the contents disclosed in the description. If the generalization of a claim is such that the person skilled in the art can reasonably doubt that one or more specific terms or options included in the generic terms or parallel options cannot solve the technical problem aimed to be solved by the invention or utility model and achieve the same technical effects, then it shall be taken that the claim is not supported by the description. In these cases, the examiner shall raise an objection of lack of support on the ground of Article 26.4 and invite the applicant to amend the claim.

As for a broadly generalized claim relating to the whole class of products or machines, if it is fairly supported by the description, and there is no reason to suppose that the invention or utility model cannot be worked through the whole of the field claimed, then the claim may be acceptable even if its extent of protection is broad. However, if the information given in the description is insufficient to enable a person skilled in the art to extend the teaching of the description to the extent of protection claimed in the claim by using routine methods of experimentation or analysis, the examiner shall invite the applicant to explain and establish that a person skilled in the art can readily extend the invention or utility model to the extent of protection claimed in the claim on the basis of the information given in the description; otherwise, the examiner shall invite the applicant to restrict the claim. (GUIDELINES FOR PATENT EXAMINATION, Part II, Chapter 2, Section 3 “The Claims”, 3.2.1 “Support in the Description”)

In Claim 1, the following features are explicitly recited:

- (a) “a selected current condition or voltage condition”
- (b) “calculating the net coulomb charge charged/discharged (ΔQ_{ap}) of the rechargeable battery based on the amount of change (ΔV_{zero}) of the said zero-current state voltage (V_{zero})”

Because the feature (a) is ambiguous, it isn't taken into account in the discussion below, and the discussion is under the presumption that the above mentioned defect has been overcome by adding to claim 1 the technical feature related to the condition disclosed in the description, such as “the condition in which the measured current or the measured potential sustain a selected current condition or a selected voltage condition for a predetermined period of time being a condition in which the said current and voltage have continuously stabilized for a determined period of time”.

Based on the description, the problem to be solved by the invention is to reduce the influence of measurement errors of the current and in approximating the charged/discharged amount of net coulomb charge, and to approximate the amount of net coulomb charge charged/discharged in a rechargeable battery more accurately.

As a means to solve the above mentioned problem, the description contains the following means: “the current terminal potential of the rechargeable battery are constantly measured at first. Then, the condition in which the measured current or the measured potential sustain a selected current condition or a selected voltage condition for a predetermined period of time is considered as a condition in which the said current and voltage have continuously stabilized for a determined period of time. Based on the average amount of the potential and current measured during the predetermined period of time and the component resistance of the rechargeable battery, the voltage of the rechargeable battery when current is not flowing, that is, the potential at zero-current state and the amount of its

change are calculated”, “based on the correlation between the amount of change of the current and the amount of net coulomb charge charged/discharged (the closer to full charge, the smaller the temporal change), and using the coefficient determined as appropriate based on the measured data for the amount of change of the potential at zero-current state and the amount of net coulomb charge charged/discharged, and the one-dimensional approximation function, the method approximates the amount of net coulomb charge charged/discharged from the calculated amount of change for the potential at zero-current state that was previously calculated”.

Regarding (b), the person skilled in the art can understand that the above feature (b) in claim 1 means calculating ΔQ_{ap} from ΔV_{zero} by using any method or formula well known in the prior art.

The description states the followings: “As the present invention approximates the amount of net coulomb charge charged/discharged ΔQ_{ap} based on the function formula using the zero-current state voltage that is less influenced by measurement errors of the current, it has an effect of accurately approximating the amount of net coulomb charge charged/discharged in a rechargeable battery”, “For example, by using the following formula decided on based on the measured data as the approximation function of the amount of change of the zero-current state potential and the amount of net coulomb charge charged/discharged for the rechargeable battery that is the object of measurement, the approximation of the amount of net coulomb charge charged/discharged (ΔQ_{ap}) in a rechargeable battery is calculated from the amount of change of the zero-current state potential (ΔV_{zero}) calculated before. $\Delta Q_{ap} = \kappa \times \Delta V_{zero} + \delta$ (κ and δ : Constants set in advance based on the measured data)”.

The means to calculate ΔQ_{ap} from ΔV_{zero} is also well known in the prior art.

Based on the description and the common general knowledge in the art, the person skilled in the art can reasonably predict that all methods and formula disclosed in the description and in the prior art that are capable of calculating ΔQ_{ap} from ΔV_{zero} can solve substantially the same technical problem and achieve substantially the same expected effects.

Definition by the feature (b) in claim 1 does not embrace the means which is incapable of solving the technical problem aimed to be solved by the invention. Then the feature (b) in claim 1 can be allowed.

To sum up, the definition by the feature (b) is permissible, and thus claim 1 meets the support requirement.

6. In Question 4 above, if you chose “No” (the claimed invention does not meet the support requirement) or “both Yes and No,” please provide the reasons for your response, in the space below:

Case Study 5 on Hypothetical Case

Name of Office: USPTO

Please fill in the examination results at your office on the following issues to be considered:

1. Does the invention of Claim 1 meet the clarity requirement?

- Yes**
 No
 Both Yes and No

2. In Question 1 above, if you chose “Yes” (the claimed invention meets the clarity requirement) or “Both Yes and No,” please provide the reasons for your response in the space below.

- (a) The invention of claim 1 meets the clarity requirement with regard to the recited “selected current condition or voltage condition.” One skilled in the art would appreciate that this refers to a “predetermined” [*i.e.*, arbitrary] current or voltage condition. The expression is merely broad. When read in light of the Description, one would understand “condition” to refer to a magnitude or to a degree of fluctuation in magnitude. The Description provides an illustrative example of each, to which the invention (as claimed) is clearly not limited.
- (b) The invention of claim 1 also meets the clarity requirement with regard to the statement “calculating the estimated amount of net coulomb charged/discharged (ΔQ_e) of the rechargeable battery based on the amount of change (ΔV_{zero}) of the said zero-current state potential (ΔV_{zero}).” Although there is no antecedent basis or previous definition of “the amount of change (ΔV_{zero}) of the said zero-current state potential (ΔV_{zero}),” one skilled in the art would understand that an amount of change in zero-current state potential (ΔV_{zero}) is to be found between a zero-current state potential (ΔV_{zero}) calculated at two arbitrary times. The expression is merely broad. The language, calculating the estimated amount of net coulomb charge charged/discharged (ΔQ_e) of the rechargeable battery “based on” this amount of change is also clear. One skilled in the art would understand that there is some established relationship between these two variables, that permits one to be estimated based upon the other. The Description provides an illustration of one such relationship, to which the invention (as claimed) is clearly not limited.
3. In Question 1 above, if you chose “No” (the claimed invention does not meet the clarity requirement) or “both Yes and No,” please provide the reasons for your response, in the space below:

4. Does the invention of Claim 1 meet the support requirement?

- Yes**
 No
 Both Yes and No

5. In Question 4 above, if you chose “Yes” (the claimed invention meets the support requirement) or “both Yes and No,” please provide the reasons for your response, in the space below:

6. In Question 4 above, if you chose “No” (the claimed invention does not meet the support requirement) or “both Yes and No,” please provide the reasons for your response, in the space below:

The claimed does not satisfy the written description requirement, because the disclosure does not demonstrate that, at the time the invention was filed, Applicant was actually in possession of the claimed invention (that is, that the invention was “ready for patenting”). The unsupported subject matter is the step of “calculating the estimated amount of net coulomb charge charged/discharged (ΔQ_e) of the rechargeable battery based on the amount of change (ΔV_{zero}) of the said zero-current state potential (ΔV_{zero}).” Neither the claim nor the Description describe how to calculate the amount of change (ΔV_{zero}) of the said zero-current state potential (ΔV_{zero}) of the “battery that is the object of the measurement.”

In the Description, a battery [or representative battery] is characterized in advance by constantly measuring the current and voltage (“constantly measured at first”). It appears that the zero-current state potential (ΔV_{zero}) [open-circuit voltage] is directly measured at various intervals whereby the relationship $\Delta Q_{ap} = \kappa \times \Delta V_{zero} + \delta$ can be determined in advance (“ κ and δ : Constants set in advance based on the measured data”).

But in finding (ΔV_{zero}) of the battery that is the object of the estimation, the only disclosure of the zero-current state potential (ΔV_{zero}) is one that is “calculated by adding a value obtained by multiplying the average amount of voltage [*sic*, current] (I_{ave}) measured within the certain period of time by the component resistance (R_{com}) to an average value (V_{ave}) measured within the certain period of time (amending the voltage drop due to component resistance) ($\Delta V_{zero} = V_{ave} + R_{com} \times I_{ave}$).

Since the (ΔV_{zero}) calculation relies on voltage and current averaged over the “certain period of time”, it cannot be inferred that an “amount of change (ΔV_{zo}) of the said zero-current state potential (ΔV_{zero})” is to be found from (ΔV_{zero}) calculated at the endpoints of the “certain period of time.” [Both calculations would rely on the same averages and yield the same the zero-current state voltage (ΔV_{zero}), such that the difference (ΔV_{zero}) would be zero].

Based on the foregoing, the amount of change (ΔV_{zero}) of the said zero-current state potential (ΔV_{zero}) of the battery that is the object of the estimation method must be found as the difference between the (ΔV_{zero}) calculated over the “certain time period” and some other said zero-current state potential (ΔV_{zero}). The Description does not say what other (ΔV_{zero}) is to be used in finding this difference. As such, the Description does not demonstrate that, at the time the invention was filed, Applicant knew what other (ΔV_{zero}) was to be used in carrying out the method. Not even one embodiment is described. It is not clear whether Applicant was in possession of estimating the total charge used, the charge remaining, only the charge used between two intervals satisfying the specific current or voltage condition.

3. Case 6

(1) Hypothetical Case

Case 6

[Claims]

1. A stamping device comprising:
stamp blocks having stamps on upper surfaces thereof;
stamp units for stamping a date;
grooves;
a case; and
a base.

[Description]

A problem to be solved by the invention is to provide a stamping device suited for stamping dates on business cards stored inside a business-card case.

Figure 1 is a view of the business card case according to one of the embodiments in the present invention. As shown in Figure 1, the business-card case comprises a card-containing section with a hole located where a date is to be printed on a card inside the case; and a case (see Figure 3) contained in a case-containing section that has a window used for stamping a date by using the stamp units for stamping dates (see Figure 2) where the above-mentioned hole is located. In addition, the above mentioned stamp units for stamping dates in Figure 2 has a connecting structure so that plural stamp blocks having stamps on upper surfaces thereof are connected and can move up and down, in order for the stamp blocks to be positioned for stamping dates. Also, stamp units for stamping dates are inserted into grooves that are formed concentrically in the case (See Figure 3).

Also, at a place in the grooves in the above mentioned case shown in Figure 3, which is where the window is located for stamping dates, a set of stamp bases is fixed in a predetermined position of the case, in order to position the stamp blocks for setting dates. These fixed stamp bases set the stamp blocks at positions higher than other stamp blocks, thereby being positioned for the printing operation.

When setting dates, users change each of the stamp units in the case accordingly with their fingers or by using a tool such as tweezers. They slide the stamp blocks in the grooves to arrange dates by year, a month, and a day, as shown in Figure 3, in order to position them on the above-mentioned stamp bases. Also, a protrusion-like tab may be provided somewhere in the stamp unit to be picked by fingers. By doing so, the top surfaces of the stamp blocks being set on the fixed stamp bases are positioned higher than the surfaces of other stamp blocks. As a result, they are positioned to print dates through the hole (window) shown in Figure 1 on a name card that is contained in the section for holding name cards, as shown in Figure 1.

[Drawings]

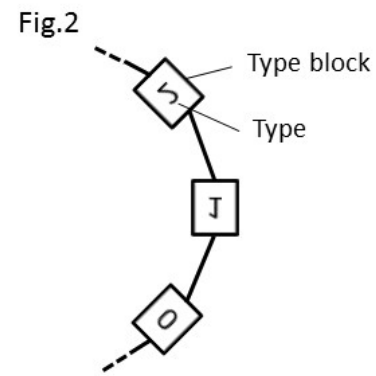
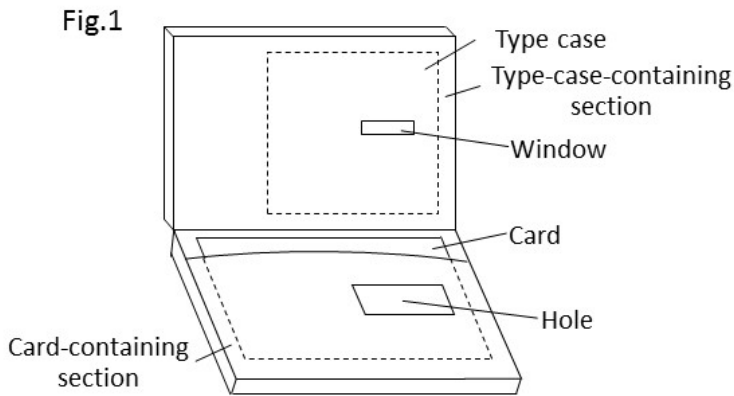

Top view showing a type unit

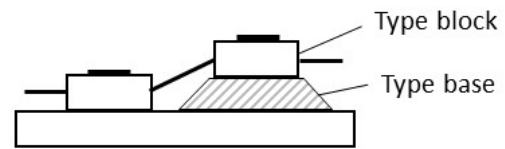
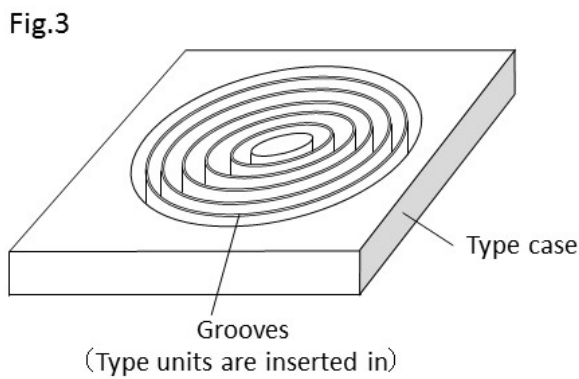

Side view showing a type base

Issues to be Considered

- Is the invention of Claim 1 unclear because of the statement in Claim 1, which does not identify any structural relationship between “stamp blocks having stamps on upper surfaces thereof,” “stamp units for printing dates,” “grooves,” “a stamp case,” and “stamp bases?”
- Does the invention of Claim 1 meet the support requirement?

3. Case 6

(2) Case Study by IP5 Offices

Case Study 6 on Hypothetical Case

Name of Office: EPO

Please fill in the examination results at your office on the following issues to be considered:

1. Does the invention of Claim 1 meet the clarity requirement?

- Yes**
 No
 Both Yes and No

2. In Question 1 above, if you chose “Yes” (the claimed invention meets the clarity requirement) or “both Yes and No,” please provide the reasons for your response, in the space below:

3. In Question 1 above, if you chose “No” (the claimed invention does not meet the clarity requirement) or “both Yes and No,” please provide the reasons for your response, in the space below:

The mere listing of structural elements without any definition of the interrelation and arrangements in which the parts are put into working with each other does not allow the skilled person to understand how the device is put into working. Any technical effect is not apparent from the features alone, but requires that the structural relationships be defined. In this case, the structural relationship between the elements in the claim is not defined.

So although an applicant is in principle allowed to draft a claim in the form of a list of structural features, present claim 1 is not clear, for the following reasons:

The text of the claim is reproduced here below:

1. “1. A stamping device comprising:
stamp blocks having stamps on upper surfaces thereof;
stamp units for stamping a date;
grooves;
a case; and
a base.
.”

Section F-IV 4.1 of the European Guidelines for examination indicates that: “... the meaning of the terms of a claims must, as far as possible, be clear for the person skilled in the art from the wording of the claim alone”.

The terms used in the claim are, when taken individually clear in the sense that they have a technical meaning which can be identified and understood by the skilled person.

However, the present “list” format claim including very little or no information on the function of particular feature e.g. . “grooves” renders the claim difficult to interpret. The scope of the claim is therefore rather vague. A vague scope would lead to an objection of lack of clarity of the claim.

EPO examiners are requested to object to a claim when essential features are missing in a claim: “The claims which define the matter for which protection is sought must be clear, meaning not only that a claim must be comprehensible from a technical point of view, but also that it must define clearly all the essential features of the invention Furthermore, the requirement of Art. 84 that the claims be supported by the description applies to features which are explicitly presented in the description as being essential for carrying out the invention. ... A lack of essential features in the independent claim(s) is therefore to be dealt with under the clarity and support requirements” (EPO Guidelines section F-IV 4.5.1).

Starting from this approach and in view of the problem to be solved as given in the description:

“A problem to be solved by the invention is to provide a stamping device suited for printing dates on business cards stored inside a business-card case.”, it would appear that at least the feature of the description related to the groove and its technical relationship with the stamp units, namely:

“When setting dates, users change each of the stamp units in the stamp case accordingly with their fingers or by using a tool such as tweezers. They slide the stamp blocks in the grooves to arrange dates by year, a month, and a day” is an essential feature of the invention. The EPO examiner would therefore likely object to this and invite the applicant to amend the claim based on the underlined feature.

Moreover, there is not mentioned any printing substance (for example ink) that is applied to the card to make the date visible on the business card; it is not clear how the ink is applied to the stamps in order to transfer the ink from the stamps onto the business card afterwards

4. Does the invention of Claim 1 meet the support requirement?

- Yes**
 No
 Both Yes and No

5. In Question 4 above, if you chose “Yes” (the claimed invention meets the support requirement) or “both Yes and No,” please provide the reasons for your response, in the space below:

6. In Question 4 above, if you chose “No” (the claimed invention does not meet the support requirement) or “both Yes and No,” please provide the reasons for your response, in the space below:

Even if all the features of claim 1 find a support in the description, the claim is however not supported by the description because essential feature(s) for solving the problem to be solved as expressed in the description are missing in the claim, i.e. the description is teaching a different set of essential features to the claim and so does not support it in the sense of Article 84 EPC.

Specifically at least the relationship between the grooves and the stamp units for setting a date should be mentioned in the claim (relevant passage of the description: “When setting dates, users change each of the stamp units in the stamp case accordingly with their fingers or by using a tool such as tweezers. They slide the stamp

blocks in the grooves to arrange dates by year, a month, and a day, as shown in Figure 3, in order to position them on the above-mentioned stamp bases.” (See description page 7, last paragraph (corresponds to fourth paragraph)) and “Also, stamp units for printing dates are inserted into grooves that are formed concentrically in the stamp case” (description, page 7, first paragraph (corresponds to second paragraph)).

It is also noted that it is not disclosed in the whole text how printing substance (for example ink) is applied to the stamps in order to transfer the printing substance from the types to the business card afterwards. This might even be considered a contravention of Article 83 EPC, depending on the person skilled in the art – i.e. if said person would interpret “stamp base” as meaning a self-inking device.

Case Study 6 on Hypothetical Case

Name of Office: JPO

Please fill in the examination results at your office on the following issues to be considered:

1. Does the invention of Claim 1 meet the clarity requirement?

- Yes**
 No
 Both Yes and No

2. In Question 1 above, if you chose “Yes” (the claimed invention meets the clarity requirement) or “both Yes and No,” please provide the reasons for your response, in the space below:

3. In Question 1 above, if you chose “No” (the claimed invention does not meet the clarity requirement) or “both Yes and No,” please provide the reasons for your response, in the space below:

As mentioned in the above Case Study 4, in order to meet the clarity requirement, the scope of the claimed inventions shall be clear and also, since an invention for which a patent is sought is described on a claim-by-claim basis, one invention should be identified based on matters stated in one claim. (Examination Guidelines, Part II, Chapter 2, Section 3 “Clarity Requirement”, 2.1 “Basic ideas of determination of clarity requirement”).

Based on this, for example, even though taking into account the statements of the description and the common general knowledge of the inventions in the art as of the time of the filing, the claimed inventions are considered to be a violation of clarity requirement, in cases when: (1) the technical meaning of a matter specifying the invention, i.e. the function or role that these elements play in the claimed invention, is incomprehensible to a person skilled in the art ; and (2) it is evident that the matter specifying the invention is deficient in light of the common general knowledge as of the filing. (Examination Guidelines, Part II, Chapter 2, Section 3 “Clarity Requirement”, 2.2 “Types of violation of clarity requirement”)

In Claim 1, when looking at the descriptions of “stamp block having stamps on upper surfaces thereof,” “stamp units for stamping dates,” “grooves,” “a case,” and “ a base,” no structural relationship between each of them is stated. Based on this, even though taking into account the statement of the description and the drawings as well as the common general knowledge in the art, the technical meaning of a matter specifying the invention, i.e. the function or role that these elements play in the invention of Claim 1, is incomprehensible to a person skilled in the art.

Furthermore, in the case of inventions that are stamping devices, it is common general knowledge in the art that the structural relationship between each of the parts differs significantly depending on the technical meaning of each part. When considering this common general knowledge, it is evident that the matters are deficient for persons skilled in the art to understand the structural relationship among each of the above-

mentioned matters. Therefore, the invention cannot be clearly identified from the statement of Claim 1.

Also, since the statement of the description and drawings include the specific modes for carrying out the structural relationship among each of the above-mentioned matters, persons skilled in the art can understand the roles performed by the above-mentioned matters in these specific modes for carrying out the structural relationship. However, in Claim 1, no structural relationships are stated, and as a result, the roles performed by these matters in the invention of Claim 1 cannot be interpreted in such a restrictive way as in the description. Therefore, even though taking into account the statement of the description and the drawings, persons skilled in the art are not able to understand the technical meanings of these matters from the statement of Claim 1.

Based on the above, the invention of Claim 1 does not meet the clarity requirement.

4. Does the invention of Claim 1 meet the support requirement?

- Yes**
- No**
- Both Yes and No**

5. In Question 4 above, if you chose “Yes” (the claimed invention meets the support requirement) or “both Yes and No,” please provide the reasons for your response, in the space below:

6. In Question 4 above, if you chose “No” (the claimed invention does not meet the support requirement) or “both Yes and No,” please provide the reasons for your response, in the space below:

As mentioned in the above Case Study 4, a claimed invention shall be disclosed in the description (Patent Act, Article 36 (6) (i)). The examiner examines a substantial correspondence between the claimed invention and the invention stated in the description. The consideration of the substantial correspondence done by the examiner is to examine whether or not the claimed invention exceeds “the extent of disclosure in the description to which a person skilled in the art would recognize that a problem to be solved by the invention would be actually solved.” (Examination Guidelines, Part II, Chapter 2, Section 2 “Support Requirement”, 2. “Determination of Support Requirement”)

Here, it can be said that, based on the statement of the description, the problem to be solved by the claimed invention is to provide a stamping device suitable for stamping dates on business cards stored in a business-card case.

As a means to solve the above-mentioned problem, the description and the drawings state a stamping device comprising: stamp units for stamping dates which have connecting structures so that plural stamp blocks having stamps on upper surfaces thereof are connected and can move up and down (in order for the stamp blocks to be positioned for stamping dates); a case in which a number of the above-mentioned stamp units are inserted into grooves that are formed concentrically in the case; and a set of bases fixed in a predetermined position in the grooves formed in the above mentioned case, in order to position the above mentioned stamp blocks for setting

dates, which are positioned higher than other stamp blocks. (See Figures 1 to 3 and the description on these drawings)

However, it is recognized that Claim 1 does not include any statement of means to solve the above-mentioned problem, including the structural relationship among “stamp block having stamps on upper surfaces thereof,” “stamp units for stamping dates,” “grooves,” “a case,” and “a base” of the stamping device.

Based on this, the invention of Claim 1 exceeds the extent of the disclosure in the description and drawings of the claimed invention.

Therefore, the invention of Claim 1 does not meet the support requirement.

Case Study 6 on Hypothetical Case

Name of Office: KIPO

Please fill in the examination results at your office on the following issues to be considered:

1. Does the invention of Claim 1 meet the clarity requirement?

- Yes**
 No
 Both Yes and No

2. In Question 1 above, if you chose “Yes” (the claimed invention meets the clarity requirement) or “both Yes and No,” please provide the reasons for your response, in the space below:

3. In Question 1 above, if you chose “No” (the claimed invention does not meet the clarity requirement) or “both Yes and No,” please provide the reasons for your response, in the space below:

Claim 1 does not establish a stamping device, a stamp unit, grooves, a systematic connection between a case and a base or working processes, but simply lists each component of which the claimed invention is consisting. Therefore, it shall be determined that the person skilled in the art cannot arrive at the present invention ‘the input device with which a date is inserted in the business card’ based on the concerned description.

Therefore, it can be determined that the scope of the claim as above mentioned is unclear pursuant to Article 42(4)(ii) of the Patent Act of Korea.

4. Does the invention of Claim 1 meet the support requirement?

- Yes**
 No
 Both Yes and No

5. In Question 4 above, if you chose “Yes” (the claimed invention meets the support requirement) or “both Yes and No,” please provide the reasons for your response, in the space below:

Whether the claim is supported by the description of the present invention is determined by whether a matter corresponding to the subject of the claim is stated in the description of the present invention, from the view point of the person skilled in the art. Rather than literal identical between the claims and the description of the invention, it should more closely be reviewed whether the claim refers to a subject which is beyond the scope of the description of the invention, from the perspective of the person skilled in the art.

In case of the above claim, even though a detailed description of the invention states the composition and the working principle with respect to ‘a stamping device to stamp the date into a business card’ , it is determined that to embody a stamping device of the claim based on a detailed description of the invention has

neither generalized nor extended beyond the scope of the description of the invention from the view point of the person skilled in the art, and that the person skilled in the art can understand the composition of and the working effect of the subject of the claim.

Therefore, the above claim is determined to be supported by a detailed description of the invention.

6. In Question 4 above, if you chose "No" (the claimed invention does not meet the support requirement) or "both Yes and No," please provide the reasons for your response, in the space below:

Case Study 6 on Hypothetical Case

Name of Office: CNIPA

Please fill in the examination results at your office on the following issues to be considered:

1. Does the invention of Claim 1 meet the clarity requirement?

- Yes**
- No**
- Both Yes and No**

2. In Question 1 above, if you chose “Yes” (the claimed invention meets the clarity requirement) or “both Yes and No,” please provide the reasons for your response, in the space below:

According to Patent Law, Article 26.4, the claims shall define clearly and concisely the matter for which protection is sought in terms of the technical features of the invention. Since the claims are used for the basis of determination of the scope for which protection is sought for by an invention, the statement in the claims has great significance. According to the Article, the requirement that the claims shall be clear means, on one hand, individual claims shall be clear, and on the other hand, the claims as a whole shall be clear as well.

2.1 individual claims shall be clear

Based on this, it is necessary that the category of each claim shall be clear and the scope of protection as defined by each claim shall be clear. The scope of protection of a claim shall be construed according to the meaning of the words used in the claim. Generally, the words used in a claim shall be understood as having the meaning which they normally have in the relevant art. And any terms which meaning is indefinite shall not be used in a claim, unless such terms have a well-recognized definite meaning in the particular art. Also, generally, such terms as “about”, “approximately”, “etc.” and the like shall not be used in a claim, since they are likely to make the scope of the claim unclear.

2.2 claims as a whole shall be clear

This means that the reference relations between the claims shall be clear. The additional technical feature of a dependent claim should be a feature that further defines the technical features of the claim on which it depends, or may be a feature newly introduced. And the technical features which further defined by the dependent claim must be stated in the claim on which the dependent claim depends.

2.3 about this case

In claim 1, the subject matter indicates clearly that this is a product claim. And in this product claim, the features such as “stamp block”, “stamp unit”, “grooves”, “case”, and “base” which be used to define the product “stamping device” are structural features. A person skilled in the art can understand the category of claim 1, and the main components of the stamping device defined in claim 1.

The technical features used in claim 1 all have definite meaning in the art, and they will not define different scope of protection in claim 1 or make the scope of claim 1 unclear.

Finally, in the case of a stamping device, it is common general knowledge in the art that the structural relationship between each of the parts, a person skilled in the art would understand know the possible relationship among those parts stated in the claim 1.

Based on the above, the invention claim 1 is clear and meets the clarity requirement under Article 26.4.

3. In Question 1 above, if you chose “No” (the claimed invention does not meet the clarity requirement) or “both Yes and No,” please provide the reasons for your response, in the space below:

4. Does the invention of Claim 1 meet the support requirement?

- Yes
- No
- Both Yes and No

5. In Question 4 above, if you chose “Yes” (the claimed invention meets the support requirement) or “both Yes and No,” please provide the reasons for your response, in the space below:

6. In Question 4 above, if you chose “No” (the claimed invention does not meet the support requirement) or “both Yes and No,” please provide the reasons for your response, in the space below:

The claims shall be supported by the description and shall define clearly and concisely the extent of the patent protection asked for (Patent Law, Article 26.4). That the claims shall be based on the description means that the claims shall be supported by the description. The technical solution for which protection is sought in each of the claims shall be a solution that a person skilled in the art can reach directly or by generalization from the contents sufficiently disclosed in the description, and shall not go beyond the scope of the contents disclosed in the description.

When the person skilled in the art can reasonably predict that the equivalents or obvious variants of the embodiments set forth in the description have the same properties or uses, then the applicant shall be allowed to generalize the protection scope of the claim to cover all the equivalents or obvious variants. If the generalization of the claim is such that the person skilled in the art can reasonably doubt that one or more specific terms or options included in the generic terms or parallel options cannot solve the technical problem aimed to be solved by the invention and achieve the same technical effects, then it shall be taken that the claim is not supported by the description.

In this case, claim 1 states a stamping device comprising: stamp blocks having stamps on upper surfaces thereof, stamp units for stamping a date, grooves, a case, and a base. While according to statement of the description, the problem to be solved by the claimed invention is to provide a stamping device suitable for stamping dates on business cards stored in a business-card case. As a means to solve the above-mentioned problem, the description and the drawings state a stamping device comprising: stamp units for stamping dates which have connecting structures so that plural stamp blocks having stamps on upper surfaces thereof are connected and can move up and down (in order for the stamp blocks to be positioned for printing dates); a case in which a number of the above-mentioned stamp units is inserted into grooves that are formed concentrically in the case; and a set of bases fixed in a predetermined position in the grooves formed in the above mentioned case, in order to position the above mentioned stamp blocks for setting dates, which are positioned higher than other stamp blocks. (See Figures 1 to 3 and the description on these drawings). And a person skilled in the art can recognize that some other connecting relationships cannot solve the problem. Based on the above, the scope of claim 1 is too broad to be supported by the description of the invention.

Therefore, the invention of claim 1 does not meet the support requirement.

Case Study 6 on Hypothetical Case

Name of Office: USPTO

Please fill in the examination results at your office on the following issues to be considered:

1. Does the invention of Claim 1 meet the clarity requirement?

- Yes**
 No
 Both Yes and No

2. In Question 1 above, if you chose “Yes” (the claimed invention meets the clarity requirement) or “both Yes and No,” please provide the reasons for your response, in the space below: **N/A**

3. In Question 1 above, if you chose “No” (the claimed invention does not meet the clarity requirement) or “both Yes and No,” please provide the reasons for your response, in the space below:

Claim 1 does not meet the clarity requirement.

Upon review of claim 1, the only material set forth is a “**listing**” of components – **1)** stamp blocks having numerical characters on the upper surfaces thereof; **2)** stamp units for stamping a date; **3)** grooves; **4)** a case and **5)** a base. No structural relationship/interconnection is set forth for any of the components. Looking at the claim, one of ordinary skill in the art would not comprehend how these components cooperate together to result in a “stamping device”. **Figures 1-3 and the description (lines 3-18)** set forth the working relationship between the individual components to provide a working stamp device that can accomplish the desired result (solution to the problem being solved). However, claim 1 provides no additional language concerning the relationship between **any** of the components and one of ordinary skill would not be held to the exact language of the specification when interpreting the claim language (the claim is simply interpreted as presently set forth). Even given the general knowledge of these common components in print devices, claim 1 gives no guidance whatsoever as to how these components work/function together to accomplish the desired result (these components may be arranged in various configurations in similar devices). In summary, the clarity requirement concerning claim 1 has not been met.

4. Does the invention of Claim 1 meet the support requirement?

- Yes**
 No
 Both Yes and No

5. In Question 4 above, if you chose “Yes” (the claimed invention meets the support requirement) or “both Yes and No,” please provide the reasons for your response, in the space below: **N/A**

6. In Question 4 above, if you chose “No” (the claimed invention does not meet the support requirement) or “both Yes and No,” please provide the reasons for your response, in the space below:

Claim 1 does not meet the support requirement.

As noted previously, **Figures 1-3 and the description (lines 3-18)** set forth an operable embodiment of the stamp device. The structural relationship between the **5 major components (listed above)** are set forth to provide a complete working device. However, since claim 1 does not include any of the structural relationship between the components, the claim encompasses more than the description can support. The open-ended language of the claim (just a listing of components) provides for multiple possible variations of the device, which would not be considered as being supported by the description. In addition, claim 1 does not include/provide for a solution/means to solve the problem at hand. The simple listing of components do not provide for a device to accomplish the stated solution. In summary, the support requirement concerning claim 1 has not been met.

4. Outline of IP5 Offices' Case Studies

Case 4

	EPO	KIPO	JPO
1.	Yes	Yes	Yes
2.	<p>The 'means for' formulation is well established in the Computer Implemented Inventions field. See GL, F-IV, 4.13: "in the data-processing/computer program field, apparatus features of the means-plus-function type ("means for ...") are interpreted as means adapted to carry out the relevant steps/functions, rather than merely means suitable for carrying them out". When reading the claim with a mind willing to understand, the limitations to the device are clearly deductible. The formulation leaves room for different implementations, e.g. by software, by dedicated hardware such as a processor or a combination thereof.</p> <p>Regarding the first functional feature, namely: "touch detection means (31) for determining whether or not a touch has occurred in a predetermined area where no keys of the keyboard layout (15) are displayed on the touch screen (12)",</p> <p>this feature is considered to be clear as the skilled person of the human machine interface, more specifically of the field of smart phones or tablets with touch screen (as mentioned in the opening paragraph of the description stating the field of the invention) would know how to design such "touch detection means".</p> <p>The function (conditional determination) performed by the touch operation detection means is also well and clearly specified.</p> <p>For assessing clarity of functional claims EPO examiners refer to Article 84 EPC of the European Patent Convention (EPC) which reads: "The claims shall define the matter for which protection is sought. They shall be clear and concise and be supported by the description" and also in particular to the European Guidelines part F-IV 2.1 ("Functional features may be included provided that a skilled person would have no difficulty in providing some means of performing this function without exercising inventive skill").</p> <p>The second functional feature reads: "keyboard changing means (33)</p>	<p>If the person skilled in the art could understand the claimed subject-matter, taking into account a detailed description or drawing(s) and the background art as filed, it shall be determined, in principle, that the claimed invention is clearly and concisely established.</p> <p>In case of the above claim, as the person skilled in the art could clearly understand the claimed subject-matter and the statement "means for...", taking into account a detailed description or drawing(s), it can be determined that the concerned claim satisfies the requirement of Article 42(4)(ii) of the Patent Act of Korea.</p>	<p>Inventions claimed in patent applications shall be clear (Patent Act, Article 36 (6) (ii)). The statement in the claims has great significance, since the claims are used for the basis of determination on novelty and inventive step, etc., and also used for the basis of determination of the technical scope of a patented invention. Thus, it is necessary that an invention can be clearly identified from one claim. The requirement under Article 36 (6) (ii) is stated to ensure such necessity. For a claimed invention to be clearly understood, it is necessary that the scope of the claimed invention shall be clear, that is to say, that the claims shall be stated such that a person skilled in the art can understand whether a specific product or process falls within the scope of the claimed invention, and to that end, the matter specifying the invention shall be clear. Also, since an invention for which a patent is sought is described on a claim-by-claim basis, one invention should be identified based on matters stated in one claim. (Examination Guidelines, Part II, Chapter 2, Section 3 "Clarity Requirement", 2.1 "Basic ideas of determination of clarity requirement"). Based on this, if a claim includes the expression of a function or characteristics, etc., there may be cases where, although the scope of the invention is clear, it is evident, even in light of the common general knowledge as of the filing, that a matter specified by the function or characteristics, etc. is not sufficiently specified from a technical perspective, and the claimed invention cannot be examined precisely on the patentability, such as novelty or inventive step, etc. based on the statement of the claim, even by considering the statements of the description and drawings. In such case, the function of the claims, which requires that an invention shall be clearly identified from one claim, is not secured, and therefore, the claim violates the clarity requirement. (Examination Guidelines, Part II, Chapter 2, Section 3 "Clarity Requirement", 4. "Claims including Specific Expressions")</p> <p>Invention of Claim 1 contains statements that are designed to describe matters specifying the claimed invention by using the following functions and characteristics:</p> <p>(1) "touch detection means (31) for determining whether or not a touch has occurred in a predetermined area where no keys of the keyboard layout(15) are displayed on the touch screen (12)"</p> <p>(2) "keyboard changing means (33) for changing a keyboard layout displayed on the touch screen to another keyboard layout stored in the memory (34) when the touch detection means (31) determines that a touch has occurred in</p>

	<p>for changing a keyboard layout (15) displayed on the touch screen to another keyboard layout (15) stored in the memory (34) when the touch detection means (31) determines that a touch has occurred in the predetermined area".</p> <p>As for the first functional feature the skilled person would easily understand the function of the display switching control means and how to design such a keyboard changing means to perform said function. The passage of this second functional feature: "when the touch detection means (31) judges that a touch has occurred in the predetermined area" teaches that the keyboard changing means changes the keyboard layout image only if a touch operation has been performed in a specified area where no keys of the keyboard layout image (15) are arranged on the touch screen. Therefore the touch operation is limited to the embodiment described on third paragraph of page 2 (corresponds to sixth paragraph) of the description, defining that the touch occurs in a specified area. The specified area being defined as follows: "The above mentioned specified area is an area where no keys of the keyboard layout image are arranged on the touch screen 12".</p> <p>Note: Even though in the field of CII the examiner would understand that "means for" in this functional feature should mean "means adapted to", the applicant could have drafted the claims even more clearly by formulating the claim e.g. as "keyboard changing means (33) adapted to change a keyboard layout (15) displayed on the touch screen to another keyboard layout (15) stored in the memory (34) when the touch detection means (31) determines that a touch has occurred in the predetermined area". The application describes one way of carrying out this adaptation paragraph 8, i.e. one way of adapting the keyboard changing means is included in the paragraph describing the sending of the signal between the touch detection unit and the keyboard changing unit.</p>		<p>the predetermined area"</p> <p>Regarding (1), "touch detection means (31) for determining..." is considered to be means which persons skilled in the art can understand, by taking into account the statement of the claim and the common general knowledge of the invention in the art, as a means designed to determine that "a touch has occurred," when "a touch has occurred in a predetermined area where no keys of the keyboard layout (15) are displayed on the touch screen (12)."</p> <p>Therefore, what the description of "touch detection means (31) for determining..." exactly means can be clearly understood by persons skilled in the art.</p> <p>Also, as supplementary comments, the description, which refers to the drawings, states how the touch detection unit 31 determines that a touch has occurred. That is, the determination is done when a touch has occurred by users with their fingers or by using a touch pen 20 in a predetermined area where no keys of the keyboard layout 15 are displayed on the touch screen 12, and then when such information is sent to the unit 31. And, it has been found that a method for determining that a touch has occurred after such touch is: (i) to convert the information on the touch into a digital signal; (ii) to send this signal by a means, such as a voltage pulse; and (iii) based on the signal information, and by using general purpose programs stored in the unit, to determine that a touch has occurred. By taking into account the common general knowledge of the invention in the art, it is recognized that this method can be very generally adopted and would be sufficiently understood by persons skilled in the art. Therefore, when considering the description and the drawings, in addition to the statement of the claim, the meaning of "touch detection means 31 for determining..." can be specifically understood by persons skilled in the art.</p> <p>Regarding (2), "keyboard changing means (33) for changing..." is considered to be means which persons skilled in the art can understand, by taking into account the statement of the claim and the common general knowledge of the invention in the art. That is, the persons can understand this as a means designed to change the keyboard layout, i.e. "change a keyboard layout displayed on the touch screen to another keyboard layout stored in the memory," when "the detection means (31) determines that a touch has occurred."</p> <p>Therefore, what the description of "keyboard changing means (33) for changing..." exactly means can be clearly understood by persons skilled in the art.</p> <p>Also, as supplementary comments, the description, which refers to the drawings, states how the keyboard changing unit 33 changes the keyboard layout. That is, the change is conducted when: (i) the touch detection unit 31 determines that a touch has occurred; and (ii) the unit 31</p>
--	--------------------------------------------------------------------------------------------------------------------------------------------------------------------------------------------------------------------------------------------------------------------------------------------------------------------------------------------------------------------------------------------------------------------------------------------------------------------------------------------------------------------------------------------------------------------------------------------------------------------------------------------------------------------------------------------------------------------------------------------------------------------------------------------------------------------------------------------------------------------------------------------------------------------------------------------------------------------------------------------------------------------------------------------------------------------------------------------------------------------------------------------------------------------------------------------------------------------------------------------------------------------------------------------------------------------------------------------------------------------------------------------------------------------------------------------------------------------------------------------------------------------------------------------------------------------------------------------------------------------------------------------------------------------------------------------------------------------------------------------------------------------------------------------------------------------------------------------------------------------------------------------------------------------------------------------------------------------------------------------------------------------------------------------	--	--------------------------------------------------------------------------------------------------------------------------------------------------------------------------------------------------------------------------------------------------------------------------------------------------------------------------------------------------------------------------------------------------------------------------------------------------------------------------------------------------------------------------------------------------------------------------------------------------------------------------------------------------------------------------------------------------------------------------------------------------------------------------------------------------------------------------------------------------------------------------------------------------------------------------------------------------------------------------------------------------------------------------------------------------------------------------------------------------------------------------------------------------------------------------------------------------------------------------------------------------------------------------------------------------------------------------------------------------------------------------------------------------------------------------------------------------------------------------------------------------------------------------------------------------------------------------------------------------------------------------------------------------------------------------------------------------------------------------------------------------------------------------------------------------------------------------------------------------------------------------------------------------------------------------------------------------------------------------------------------------------------------------------------------------------------------------------------------------------------------------------------------------------------------------------------------------------------------------------------------------------------------------------------------------------------------------------------------------------------------------------------------------------------------------------------------------------------------------------------------------------------------------------------------------------------------------------------------------------------------------------------------------------------------------------------------------------------------------------------------------------------------------------------------------------------------------------------------------------------------------------------------------------------------------------------------------------------------------------------

			<p>sends a signal to the keyboard changing unit 33, which indicates that a touch has occurred. As a result, the unit 33 will change a keyboard layout displayed on the touch screen 12 to another keyboard layout image stored in the memory 34. And, regarding the means for changing the keyboard layout displayed on a touch screen 12 to another keyboard layout stored in the memory 34, by taking into account the common general knowledge of the invention in the art, persons skilled in the art can sufficiently identify the very generally-adopted means such as (i) the unit 31 converts the detection information into a digital signal, which indicates that a touch has occurred; (ii) the unit 31 sends this signal by a means, such as a voltage pulse, to the unit 33; and (iii) based on the signal information, and by using general purpose programs stored in the device, the keyboard changing unit 33 obtains a layout from the keyboard layout stored in the memory 34; and (iv) the unit 33 changes a keyboard layout displayed on the touch screen 12 to the obtained keyboard layout. Therefore, when considering the description and the drawings, in addition to the statement of the claim, the meaning of "keyboard changing means 33 for changing..." can be specifically understood by persons skilled in the art. Based on the above, the claimed invention meets the clarity requirement.</p>
3.	N/A	N/A	N/A
4.	Yes	Yes	Yes
5.	<p>The support requirement is defined by the same Article 84 EPC ("The claims shall define the matter for which protection is sought. They shall be clear and concise and be supported by the description".</p> <p>The EPO examiners compare the text of the claims with that of the description and detect for instance possible mismatch or inconsistencies. EPO Guidelines further provide instructions to the examiners in section F-IV 6. The general instruction given in the EPO Guidelines reads: "The claims must be supported by the description. This means that there must be a basis in the description for the subject-matter of every claim and that the scope of the claims must not be broader than is justified by the extent of the description and drawings and also the contribution to the art".</p> <p>In the present case all the features specified in the claim and their respective function do have a basis in the description, namely:</p> <p>The opening portion of the claim:</p>	<p>Whether the claim is supported by the description of the present invention is determined by whether a matter corresponding to the subject of the claim is stated in the description of the present invention, from the view point of the person skilled in the art. Rather than literal identical between the claims and the description of the invention, it should more closely be reviewed whether the claim refers to a subject which is beyond the scope of the description of the invention, from the perspective of the person skilled in the art. In this case, it is obvious for a person skilled in the art that features written in the claim are supported by the statements of the description.</p>	<p>A claimed invention shall be disclosed in the description (Patent Act, Article 36 (6) (i)). The purpose of this requirement (support requirement) is to prevent a patent from being granted for an invention which is not disclosed to the public. (Examination Guidelines, Part II, Chapter 2, Section 2 "Support Requirement", 1. "Overview") The examiner examines a substantial correspondence between the claimed invention and the invention stated in the description to determine whether the support requirement is met. The consideration of the substantial correspondence done by the examiner is to examine whether or not the claimed invention exceeds "the extent of disclosure in the description to which a person skilled in the art would recognize that a problem to be solved by the invention would be actually solved." (Examination Guidelines, Part II, Chapter 2, Section 2 "Support Requirement", 2. "Determination of Support Requirement") It can be said that, based on the description, a problem to be solved by the claimed invention is related to handheld portable terminals, such as smartphones and tablets, and is to provide a character input device, easily enabling users to change one keyboard layout displayed on a touch screen to other keyboard layouts. As a means to solve the above</p>

	<p>“A character input device for performing character input by touching a keyboard layout image displayed on a touch screen” finds a basis in the first paragraph of page 2 (corresponds to fourth paragraph) of the description where the expression “a character input device” is literally present. The function of the input device is also supported by the same paragraph of the description together with figures 1 and 2.</p> <p>The feature “memory” and its function “for storing plurality of different types of keyboard layout images” find support in the last paragraph of page 2 (corresponds to eighth paragraph) of the description (“The memory 34 stores three types of keyboard layout images ...”).</p> <p>The feature: “touch detection means (31) for judging whether or not a touch has occurred in a predetermined area where no keys of the keyboard layout image (15) are displayed on the touch screen” is supported by text explaining figure 3 on page 2 (corresponds to figure 3) of the description.</p> <p>The feature: “keyboard changing means (33) for changing a keyboard layout image (15) displayed in the touch screen to another keyboard layout image (15) stored in the memory (34) when the touch detection means (31) determines that a touch has occurred in the predetermined area” finds its support in the fourth paragraph of page 2 of the description. (“A keyboard changing unit 33 controls displaying the keyboard layout. When the touch detection unit 31 sends a signal indicating that a touch has occurred in the predetermined area, unit 33 changes the keyboard layout image 15 currently being displayed on the touch screen to another keyboard layout image stored in the memory 34”).</p>		<p>mentioned problem, the descriptions and the drawings contain the following means: a touch detection unit for determining whether or not a touch has occurred in a predetermined area of the touch screen; and a keyboard changing unit for changing a keyboard layout displayed on a touch screen to other keyboard layouts stored in the memory, when the touch detection unit sends a signal indicating that a touch has occurred. (See Figure 3 and the detailed explanations by using Figure 3 in the description)</p> <p>In addition, by taking into account the common general knowledge of the invention in the art, which is referred to in 2 stated above, persons skilled in the art would recognize that the above mentioned problem can be solved by touch detection means, such as the above mentioned touch detection unit, and keyboard changing means, such as the above mentioned keyboard changing unit.</p> <p>Also, Claim 1 of the invention recites the above mentioned means.</p> <p>Based on the above, the invention of Claim 1 meets the support requirement.</p>
6.	N/A	N/A	N/A

	CNIPA	USPTO
1.	Yes	Yes
2.	<p>The claims shall define the extent of the patent protection sought for in a clear and concise manner. (PATENT LAW OF THE PEOPLE'S REPUBLIC OF CHINA, Article 26.4)</p> <p>The clarity of the claims is of the utmost importance for the determination of the extent for which protection is sought by an invention or utility model. The requirement that the claims shall be clear means, on the one hand, individual claims shall be clear, and on</p>	<p>35 U.S.C. 112 (b) <i>The specification shall conclude with one or more claims particularly pointing out and distinctly claiming the subject matter which the inventor or a joint inventor regards as the invention</i></p> <p>35 U.S.C. 112 (f): <i>An element in a claim for a combination may be expressed as a means or step for performing a specified function without the recital of structure, material, or acts in support thereof, and such claim shall be construed to cover the corresponding structure, material, or acts</i></p>

<p>the other hand, the claims as a whole shall be clear as well.</p> <p>A product claim is suitable for an invention or utility model of product, and shall usually be defined in terms of the structural features of the product. In particular cases, where one or more technical features in a product claim cannot be clearly expressed in terms of structural features, it is permissible to express them with the aid of physical or chemical parameters. Where the features cannot be clearly expressed in terms of either structural features or parameter features, it is permissible to express them with the aid of process features. When parameters are used for the expression, the parameters used must be those which can be clearly and reliably determined by a person skilled in the art according to the teachings of the description or by customary means of the relevant art. (GUIDELINES FOR PATENT EXAMINATION, Part II, Chapter 2, Section 3 "The Claims", 3.2.2 "Clarity")</p> <p>Usually, for product claims, features of function or effect shall be avoided as far as possible to be used in defining the invention. It is only when a certain technical feature cannot be defined by a structural feature, or it is more appropriate to be defined by a feature of function or effect than by a structural feature, and the function or effect can be directly and affirmatively verified by experiments or operations as stated in the description or by customary means in the art, that definition by features of function or effect in a product claim can be permissible.</p> <p>Technical feature defined by function in a claim shall be construed as embracing all the means that are capable of performing the function. (GUIDELINES FOR PATENT EXAMINATION, Part II, Chapter 2, Section 3 "The Claims", 3.2.1 "Support in the Description")</p> <p>Claim 1 contains functional definitions that are designed to define the technical features by the following functions and characteristics:</p> <p>(1) "touch detection means (31) for determining whether or not a touch has occurred in a predetermined area where no keys of the keyboard layout (15) are displayed on the touch screen (12)";</p> <p>(2) "keyboard changing means (33) for changing a keyboard layout (15) displayed on the touch screen to another keyboard layout (15) stored in the memory (34) when the touch detection means (31) determines that a touch has occurred in the predetermined area".</p> <p>Regarding (1), the technical feature of "touch detection means" defined by function in claim 1 shall be construed as embracing all the means that are capable of performing the function of "determining whether or not a touch has occurred in a predetermined area where no keys of the keyboard layout are displayed on the touch screen".</p> <p>Therefore, by taking into account the statement of the claim and the common general knowledge in the art, what "touch detection means for determining..." exactly means can be clearly understood by persons skilled in the art.</p> <p>Regarding (2), the technical feature of "keyboard changing means" defined by function in claim 1 shall be construed as embracing all the means that are capable of performing the function of "changing a keyboard layout displayed on the touch screen to another keyboard layout stored in the memory unit when the touch detection means determines that a touch has occurred in the predetermined area".</p> <p>Therefore, by taking into account the statement of the claim and the common general knowledge in the art, what "keyboard changing means for changing..." exactly means can be clearly understood by persons skilled in the art.</p> <p>Thus, claim 1 meets the clarity requirement.</p>	<p><i>described in the specification and equivalents thereof.</i></p> <p>Accordingly, examiners will apply 35 U.S.C. 112(f) to a claim limitation if it meets the following 3-prong analysis: (A) the claim limitation uses the term "means" or "step" or a term used as a substitute for "means" that is a generic placeholder for performing the claimed function; (B) the term "means" or "step" or the generic placeholder is modified by functional language, typically, but not always linked by the transition word "for" (e.g., "means for") or another linking word or phrase, such as "configured to" or "so that"; and (C) the term "means" or "step" or the generic placeholder is not modified by sufficient structure, material, or acts for performing the claimed function. (MPEP 2181 I. DETERMINING WHETHER A CLAIM LIMITATION INVOKES 35 U.S.C. 112(f) or PRE-AIA 35 U.S.C. 112, SIXTH PARAGRAPH)</p> <p>In claim 1, "touch detection means" and "keyboard changing means" are presumed to invoke 112(f) because they use the term "means", "means" is modified by functional language (determining...; changing...) linked by the transition word "for", and the term "means" is not modified by sufficient structure, material or acts for performing the claimed function. Therefore, they are construed to cover the corresponding structure described in the specification.</p> <p>35 U.S.C. 112(f) states that a claim limitation expressed in means- (or step-) plus-function language "shall be construed to cover the corresponding structure...described in the specification and equivalents thereof." "If one employs means plus function language in a claim, one must set forth in the specification an adequate disclosure showing what is meant by that language. If an applicant fails to set forth an adequate disclosure, the applicant has in effect failed to particularly point out and distinctly claim the invention as required by the 35 U.S.C. 112(b)" In re Donaldson Co., 16 F.3d 1189, 1195, 29 USPQ2d 1845, 1850 (Fed. Cir. 1994) (en banc). (MPEP 2181 II. DESCRIPTION NECESSARY TO SUPPORT A CLAIM LIMITATION WHICH INVOKES 35 U.S.C. 112(f) or Pre-AIA 35 U.S.C. 112, SIXTH PARAGRAPH)</p> <p>Under certain limited circumstances, the written description does not have to explicitly describe the structure (or material or acts) corresponding to a means- (or step-) plus-function limitation to particularly point out and distinctly claim the invention as required by 35 U.S.C. 112(b) or pre-AIA 35 U.S.C. 112, second paragraph. See Dossel, 115 F.3d at 946, 42 USPQ2d at 1885...Further, disclosure of structure corresponding to a means-plus-function limitation <u>may be implicit in the written description if it would have been clear to those skilled in the art what structure must perform the function recited in the means-plus-function limitation...</u>Dossel, 115 F.3d at 946-47, 42 USPQ2d at 1885 ("Clearly, a unit which receives digital data, performs complex mathematical computations and outputs the results to a display must be implemented by or on a general or special purpose computer (although it is not clear why the written description does not simply state 'computer' or some equivalent phrase)."). (MPEP 2181 II. A. The Corresponding Structure Must Be Disclosed In the Specification Itself in a Way That One Skilled In the Art Will Understand What Structure Will Perform the Recited Function)</p> <p>(A) In this case, the disclosure states: Also, Smartphone 10 contains a CPU and a memory. The CPU is a processing unit that is used to execute programs stored in the memory. The CPU performs processing to control each part of Smartphone 10 and performs various functions described later. The memory stores programs and data to carry out the invention, and also acts as the working memory of the CPU. The following are detailed explanations shown in Figure 3 about the processing when Smartphone 10 is in the keyboard operating mode.</p> <p>Though the drawings are block diagrams that do not show a specific structure for touch detection means (31) and</p>
----------------------------------------------------------------------------------------------------------------------------------------------------------------------------------------------------------------------------------------------------------------------------------------------------------------------------------------------------------------------------------------------------------------------------------------------------------------------------------------------------------------------------------------------------------------------------------------------------------------------------------------------------------------------------------------------------------------------------------------------------------------------------------------------------------------------------------------------------------------------------------------------------------------------------------------------------------------------------------------------------------------------------------------------------------------------------------------------------------------------------------------------------------------------------------------------------------------------------------------------------------------------------------------------------------------------------------------------------------------------------------------------------------------------------------------------------------------------------------------------------------------------------------------------------------------------------------------------------------------------------------------------------------------------------------------------------------------------------------------------------------------------------------------------------------------------------------------------------------------------------------------------------------------------------------------------------------------------------------------------------------------------------------------------------------------------------------------------------------------------------------------------------------------------------------------------------------------------------------------------------------------------------------------------------------------------------------------------------------------------------------------------------------------------------------------------------------------------------------------------------------------------------------------------------------------------------------------------------------------------------------------------------------------------------------------------------------------------------------------------------------------------------------------------------------------------------------------------------------------------------------------------------------------------------------------------------------------------------------------------------------------------------------------------------------------------------------------------------------------------------------------------------------------------------------------------------------------------------------------------------------------------------------------------------------------------------------------------------------------------------------------------------------------------------------------------------------------------------------------------------------------------------------------------------------------------------------------------------------------------------------------------------------------------------------------------------------------------------------------------------------------------------------------------------------------------------------------	-----------------------------------------------------------------------------------------------------------------------------------------------------------------------------------------------------------------------------------------------------------------------------------------------------------------------------------------------------------------------------------------------------------------------------------------------------------------------------------------------------------------------------------------------------------------------------------------------------------------------------------------------------------------------------------------------------------------------------------------------------------------------------------------------------------------------------------------------------------------------------------------------------------------------------------------------------------------------------------------------------------------------------------------------------------------------------------------------------------------------------------------------------------------------------------------------------------------------------------------------------------------------------------------------------------------------------------------------------------------------------------------------------------------------------------------------------------------------------------------------------------------------------------------------------------------------------------------------------------------------------------------------------------------------------------------------------------------------------------------------------------------------------------------------------------------------------------------------------------------------------------------------------------------------------------------------------------------------------------------------------------------------------------------------------------------------------------------------------------------------------------------------------------------------------------------------------------------------------------------------------------------------------------------------------------------------------------------------------------------------------------------------------------------------------------------------------------------------------------------------------------------------------------------------------------------------------------------------------------------------------------------------------------------------------------------------------------------------------------------------------------------------------------------------------------------------------------------------------------------------------------------------------------------------------------------------------------------------------------------------------------------------------------------------------------------------------------------------------------------------------------------------------------------------------------------------------------------------------------------------------------------------------------------------------------------------------------------------------------------------------------------------------------------------------------------------------------------------------------------------------------------------------------------------------------------------------------------------------------------------------------------------------------------------------------------------------------------------------------------------------------------------------------------------------------------------------------------------------------------------------------------------------------------------------------------------------------------------------------------------------------------------------------------------------------------------------------------------------------------------------------------------------------------------------------------------------------------------------------------------

		<p>keyboard changing means (33) and the disclosure does not explicitly state the claimed “means” are the CPU, it would have been clear to one of ordinary skill in the art, given the above excerpt from the disclosure, that a CPU performs the claimed functions.</p> <p>To claim a means for performing a specific computer-implemented function and then to disclose only a general purpose computer as the structure designed to perform that function amounts to pure functional claiming... In this instance, the structure corresponding to a <u>35 U.S.C. 112(f)</u> claim limitation for a computer-implemented function must include the algorithm needed to transform the general purpose computer or microprocessor disclosed in the specification (MPEP 2181 II. B. Computer-Implemented Means-Plus-Function Limitations)</p> <p>If the specification explicitly discloses an algorithm, the sufficiency of the disclosure of the algorithm must be determined in light of the level of ordinary skill in the art...The examiner should determine whether one skilled in the art would know how to program the computer to perform the necessary steps described in the specification (i.e., the invention is enabled), and that the inventor was in possession of the invention (i.e., the invention meets the written description requirement). Thus, the specification must sufficiently disclose an algorithm to transform a general purpose microprocessor to a special purpose computer so that a person of ordinary skill in the art can implement the disclosed algorithm to achieve the claimed function. Aristocrat, 521 F.3d at 1338, 86 USPQ2d at 1242 (MPEP 2181 II. B. Computer-Implemented Means-Plus-Function Limitations)</p> <p>(B) The steps described in the specification for touch detection means: A touch detection unit 31 determines whether or not a touch by users has occurred in a predetermined area of the touch screen 12. Users can touch a touch screen 12 with their fingers or by using a touch pen 20. The above mentioned predetermined area is an area where no keys of the keyboard layout 15 are displayed on the touch screen 12. This area is indicated with diagonal lines in Figure 2.</p> <p>(C) The steps described in the specification for keyboard changing unit: When the touch detection unit 31 sends a signal indicating that a touch has occurred in the predetermined area, unit 33 changes the keyboard layout 15 currently being displayed on the touch screen to another keyboard layout stored in the memory 34. The following are more specific descriptions on the above mentioned control conducted by the keyboard changing unit 33. The memory 34 stores three types of keyboard layouts in the following order: “capital-letter alphabetic characters keyboard layout,” “small-letter alphabetic characters keyboard layout,” and “ten-key numerical characters keyboard layout.” For example, in cases where a “capital-letter alphabetic keyboard layout” is displayed on the touch screen, if a signal that a touch has occurred is sent to the keyboard changing unit 33, the keyboard changing unit 33 will change the keyboard layout being displayed on the touch screen to either of the two other keyboard layouts , i.e. a “ten-key numerical characters keyboard layout ” or a “small-letter alphabetic characters keyboard layout”, stored next to this current keyboard layout in the memory 34.</p> <p>One skilled in the art would know how to program a processor to perform the necessary steps described above. There is sufficient description of how to transform the general-purpose CPU into a special-purpose CPU to perform the claimed functions.</p>
3.	N/A	N/A
4.	Yes	Yes

<p>5.</p>	<p>The claims shall be supported by the description. (PATENT LAW OF THE PEOPLE'S REPUBLIC OF CHINA, Article 26.4)</p> <p>"The claims shall be supported by the description" means that the technical solution for which protection is sought in each of the claims shall be a solution that a person skilled in the art can reach directly or by generalization from the contents sufficiently disclosed in the description, and shall not go beyond the scope of the contents disclosed in the description.</p> <p>Claims are usually generalizations from one or more embodiments or examples as set forth in the description. The generalization of a claim shall not go beyond the scope of the contents disclosed in the description. If the person skilled in the art can reasonably predict that all the equivalents or obvious variants of the embodiments set forth in the description have the same properties or uses, then the applicant shall be allowed to generalize the protection extent of the claim to cover all the equivalents or obvious variants. In determining whether the generalization of a claim is appropriate, the examiner shall refer to the relevant prior art.</p> <p>For claims generalized in generic terms or by parallel options, the examiner shall examine whether the generalization can be supported by the description. Where the generalization of a claim includes contents speculated by the applicant and the effect thereof is difficult to determine or evaluate beforehand, the generalization shall be regarded as going beyond the scope of the contents disclosed in the description. If the generalization of a claim is such that the person skilled in the art can reasonably doubt that one or more specific terms or options included in the generic terms or parallel options cannot solve the technical problem aimed to be solved by the invention or utility model and achieve the same technical effects, then it shall be taken that the claim is not supported by the description. In these cases, the examiner shall raise an objection of lack of support on the ground of Article 26.4 and invite the applicant to amend the claim.</p> <p>Usually, for product claims, features of function or effect shall be avoided as far as possible to be used in defining the invention. It is only when a certain technical feature cannot be defined by a structural feature, or it is more appropriate to be defined by a feature of function or effect than by a structural feature, and the function or effect can be directly and affirmatively verified by experiments or operations as stated in the description or by customary means in the art, that definition by features of function or effect in a product claim can be permissible.</p> <p>Technical feature defined by function in a claim shall be construed as embracing all the means that are capable of performing the function. For claim containing a feature defined by function, whether the definition by function can be supported by the description shall be examined. If the function is carried out in a particular way in the embodiments of the description, and the person skilled in the art would not appreciate that the function could be carried out by other alternative means not described in the description, or the person skilled in the art can reasonably doubt that one or more means embraced in the definition by function cannot solve the technical problem aimed to be solved by the invention or utility model and achieve the same technical effect, then the definition by function as embracing the other alternative means or means incapable of solving the technical problem shall not be allowed in the claim. (GUIDELINES FOR PATENT EXAMINATION, Part II, Chapter 2, Section 3 "The Claims", 3.2.1 "Support in the Description")</p> <p>Claim 1 contains functional definitions that are designed to define the technical features by the following functions and characteristics:</p>	<p><i>35 U.S.C. 112(a): The specification shall contain a written description of the invention, and of the manner and process of making and using it, in such full, clear, concise, and exact terms as to enable any person skilled in the art to which it pertains, or with which it is most nearly connected, to make and use the same, and shall set forth the best mode contemplated by the inventor or joint inventor of carrying out the invention</i></p> <p>When examining computer-implemented functional claims, examiners should determine whether the specification discloses the computer and the algorithm (e.g., the necessary steps and/or flowcharts) that perform the claimed function in sufficient detail such that one of ordinary skill in the art can reasonably conclude that the inventor invented the claimed subject matter. (MPEP 2161.01 I. DETERMINING WHETHER THERE IS ADEQUATE WRITTEN DESCRIPTION FOR A COMPUTER-IMPLEMENTED FUNCTIONAL CLAIM LIMITATION).</p> <p>"As a general rule, where software constitutes part of a best mode of carrying out an invention, description of such a best mode is satisfied by a disclosure of the functions of the software. This is because, normally, writing code for such software is within the skill of the art, not requiring undue experimentation, once its functions have been disclosed. . . . [F]low charts or source code listings are not a requirement for adequately disclosing the functions of software." <i>Fonar Corp.</i>, 107 F.3d at 1549, 41 USPQ2d at 1805 (citations omitted). (MPEP 2161.01 II BEST MODE)</p> <p>To satisfy the enablement requirement of <u>35 U.S.C. 112(a)</u> or <u>pre-AIA 35 U.S.C. 112</u>, first paragraph, the specification must teach those skilled in the art how to make and use the full scope of the claimed invention without "undue experimentation." (MPEP 2161.01 III. DETERMINING WHETHER THE FULL SCOPE OF A COMPUTER-IMPLEMENTED FUNCTIONAL CLAIM LIMITATION IS ENABLED)</p> <p>Given the above cited portions of the disclosure (A), (B), and (C) from the previous question, one of ordinary skill in the art would be able to make and use the invention, e.g. by programming a computer to perform the claimed functions. The description clearly sets forth the invention to enable users to easily change the keyboard layout displayed on a touchscreen of a device, where the best mode is to detect a touch on an area where no keys of a keyboard layout are displayed.</p>
-----------	---------------------------------------------------------------------------------------------------------------------------------------------------------------------------------------------------------------------------------------------------------------------------------------------------------------------------------------------------------------------------------------------------------------------------------------------------------------------------------------------------------------------------------------------------------------------------------------------------------------------------------------------------------------------------------------------------------------------------------------------------------------------------------------------------------------------------------------------------------------------------------------------------------------------------------------------------------------------------------------------------------------------------------------------------------------------------------------------------------------------------------------------------------------------------------------------------------------------------------------------------------------------------------------------------------------------------------------------------------------------------------------------------------------------------------------------------------------------------------------------------------------------------------------------------------------------------------------------------------------------------------------------------------------------------------------------------------------------------------------------------------------------------------------------------------------------------------------------------------------------------------------------------------------------------------------------------------------------------------------------------------------------------------------------------------------------------------------------------------------------------------------------------------------------------------------------------------------------------------------------------------------------------------------------------------------------------------------------------------------------------------------------------------------------------------------------------------------------------------------------------------------------------------------------------------------------------------------------------------------------------------------------------------------------------------------------------------------------------------------------------------------------------------------------------------------------------------------------------------------------------------------------------------------------------------------------------------------------------------------------------------------------------------------------------------------------------------------------------------------------------------------------------------------------------------------------------------------------------------------------------------------------------------------------------------------------------------------------------------------------------------------------------------------------------------------------------------------------------------------------------------------------------------------------------------------------------------------------------------------------------------------------------------------------------------------------------------------------------------------------------------------------------------------------------------------------------------------------------------------------------------------------------------------------------------------------------------------------------------------------------------------------------------------------------------------------	------------------------------------------------------------------------------------------------------------------------------------------------------------------------------------------------------------------------------------------------------------------------------------------------------------------------------------------------------------------------------------------------------------------------------------------------------------------------------------------------------------------------------------------------------------------------------------------------------------------------------------------------------------------------------------------------------------------------------------------------------------------------------------------------------------------------------------------------------------------------------------------------------------------------------------------------------------------------------------------------------------------------------------------------------------------------------------------------------------------------------------------------------------------------------------------------------------------------------------------------------------------------------------------------------------------------------------------------------------------------------------------------------------------------------------------------------------------------------------------------------------------------------------------------------------------------------------------------------------------------------------------------------------------------------------------------------------------------------------------------------------------------------------------------------------------------------------------------------------------------------------------------------------------------------------------------------------------------------------------------------------------------------------------------------------------------------------------------------------------------------------------------------------------------------------------------------------------------------------------------------------------------------------------------------------------------------------------------------------------------------------------------------------------------------------------------------------------------------------------------------------------------------

	<p>(1) "touch detection means (31) for determining whether or not a touch has occurred in a predetermined area where no keys of the keyboard layout (15) are displayed on the touch screen (12)"; (2) "keyboard changing means (33) for changing a keyboard layout (15) displayed on the touch screen to another keyboard layout (15) stored in the memory (34) when the touch detection means (31) determines that a touch has occurred in the predetermined area".</p> <p>Based on the description, a problem to be solved by the claimed invention is related to portable terminals, such as smartphones and tablets, and is to provide a character input device, easily enabling users to change one keyboard layout image displayed on a touch screen to other keyboard layout images (See description, paragraph 1).</p> <p>As a means to solve the above mentioned problem, the description and the drawings contain the following means: a touch detection unit for determining whether or not a touch by users has occurred in a predetermined area of the touch screen; and a keyboard changing unit for changing a keyboard layout displayed on a touch screen to another keyboard layout stored in the memory, when the touch detection unit sends a signal indicating that the touch has occurred. The description also discloses more specific operation steps performed by the touch detection unit and the keyboard changing unit (See description, paragraphs 7-9).</p> <p>Based on the description and the common general knowledge in the art, the person skilled in the art can reasonably predict that all the equivalents or obvious variants of the embodiments set forth in the description have the same properties or uses. And, the person skilled in the art can reasonably predict that definition by features of function in claim 1 does not embrace the means which is incapable of solving the technical problem aimed to be solved by the invention. Then the features (1) and (2) in claim 1 can be allowed.</p> <p>Based on the above, definition by features of function in claim 1 is permissible, and thus claim 1 meets the support requirement.</p>	
6.	N/A	N/A

Case 5

	EPO	KIPO	JPO
1.	No	Yes	Yes
2.	N/A	<p>a) As a selected current or a selected voltage is determined based on the property of the rechargeable battery, it can be determined that the current or the voltage is sufficiently specified based on the terminology itself.</p> <p>b) Even though additional explanation has not been made, the person skilled in the art may clearly understand that the 'zero-current state' means the current, which flows outside the rechargeable battery, is valued as zero, and that the zero-current state has occurred because voltage has been dropped due to the loss of electricity resulted from inward current caused by inward resistance of the rechargeable battery. Further, the above matter is sufficiently implied in the detailed description of the claimed invention.</p> <p>Therefore, it can be determined that the scope of the claim as above mentioned is clear pursuant to Article 42(4)(ii) of the Patent Act of Korea.</p>	<p>As referred to in above Case Study 4, inventions claimed in patent applications shall be clear (Patent Act, Article 36 (6) (ii)). For a claimed invention to be clearly understood, it is necessary that the scope of the claimed invention shall be clear, that is to say, that the claims shall be stated such that a person skilled in the art can understand whether a specific product or process falls within the scope of the claimed invention, and to that end, the matter specifying the invention shall be clear. (Examination Guidelines, Part II, Chapter 2, Section 3 "Clarity Requirement", 2.1 "Basic ideas of determination of clarity requirement"). In Claim 1 of the present invention, the following statement is explicitly stated: (a) "selected current condition or voltage condition"</p> <p>(b) "calculating the approximate amount of net coulomb charge charged/discharged (ΔQ_{ap}) of the rechargeable battery based on the amount of change (ΔV_{zero}) of the said zero-current state voltage (V_{zero})"</p> <p>Regarding (a), from the statement in the claim "calculating the zero-current state potential (V_{zero}) across the terminals of the rechargeable battery when a selected current condition or a selected voltage condition is maintained for a predetermined period of time during the use of such rechargeable battery", persons skilled in the art can understand that the above statement "a selected current condition or a selected voltage condition" means an arbitrary current condition or voltage condition that is set as required as a condition for calculating the zero-current state potential (V_{zero}) in a rechargeable battery.</p> <p>Therefore, the meaning of "a selected current condition or a selected voltage condition" is clear to persons skilled in the art.</p> <p>Also, as supplementary comments, the description states in regard to the above "a selected current condition or a selected condition," "the current terminal potential of the rechargeable battery are constantly measured at first. Then, the condition in which the measured current or the measured potential sustain a selected current condition or a selected voltage condition for a predetermined period of time is considered as a condition in which the said current and voltage have continuously stabilized for a determined period of time. Based on the average amount of the potential and current measured during the predetermined period of time and the component resistance of the rechargeable battery, the voltage of the rechargeable battery when current is not flowing, that is, the potential at zero-current state and the amount of its change are calculated." That is, the description states that the condition in</p>

			<p>which the above “a selected current condition or a selected voltage condition” is maintained for a certain period of time is considered as a condition in which the current and the voltage is continuously stabilized for a determined period of time.</p> <p>Therefore, when considering the description, in addition to the statement of the claim, the meaning of the above: “a selected current condition or a selected voltage condition” can be specifically understood by persons skilled in the art.</p> <p>Regarding (b), it is apparent that the “zero-current state potential (V_{zero})” means the potential when the current is zero (not flowing). Furthermore, persons skilled in the art can understand that “calculating the net coulomb charge charged/discharged (ΔQ_{ap}) of the rechargeable battery based on the amount of change (ΔV_{zero}) of the said zero-current state voltage (V_{zero})” means calculating ΔQ_{ap} from ΔV_{zero}, using the function for the amount of change of the zero-current state potential (ΔV_{zero}) and the net coulomb charge charged/discharged, based on the common general knowledge that the charged/discharged net coulomb charge correlates with the amount of change of potential for rechargeable batteries, as well as the common general knowledge that in general, the correlation between variables that correlate with each other can be expressed as appropriate through approximation that has a coefficient previously determined based on known data.</p> <p>Therefore, the meaning of “calculating the net coulomb charge charged/discharged (ΔQ_{ap}) of the rechargeable battery based on the amount of change (ΔV_{zero}) of the said zero-current state voltage (V_{zero})” is apparent to persons skilled in the art. Also, as supplementary comments, the description in regard to the “zero-current state potential (V_{zero})” states that “the voltage of a rechargeable battery when current is not flowing, that is the zero-current state potential” and “the zero-current state potential (V_{zero}) is calculated by adding a value obtained by multiplying the average amount of voltage (I_{ave}) measured within the certain period of time by the component resistance (R_{com}) to an average value (V_{ave}) measured within the predetermined period of time (amending the voltage drop due to component resistance) ($V_{zero} = V_{ave} + R_{com} \times I_{ave}$).”</p> <p>Furthermore, it is also stated in the description regarding the above statement “calculating the net coulomb charge charged/discharged (ΔQ_{ap}) of the rechargeable battery based on the amount of change (ΔV_{zero}) of the said zero-current state voltage (V_{zero})” that: “based on the correlation between the amount of change of the current and the amount of net coulomb charge charged/discharged (the closer to full charge, the smaller the temporal</p>
--	--	--	----------------------------------------------------------------------------------------------------------------------------------------------------------------------------------------------------------------------------------------------------------------------------------------------------------------------------------------------------------------------------------------------------------------------------------------------------------------------------------------------------------------------------------------------------------------------------------------------------------------------------------------------------------------------------------------------------------------------------------------------------------------------------------------------------------------------------------------------------------------------------------------------------------------------------------------------------------------------------------------------------------------------------------------------------------------------------------------------------------------------------------------------------------------------------------------------------------------------------------------------------------------------------------------------------------------------------------------------------------------------------------------------------------------------------------------------------------------------------------------------------------------------------------------------------------------------------------------------------------------------------------------------------------------------------------------------------------------------------------------------------------------------------------------------------------------------------------------------------------------------------------------------------------------------------------------------------------------------------------------------------------------------------------------------------------------------------------------------------------------------------------------------------------------------------------------------------------------------------------------------------------------------------------------------------------------------------------------------------------------------------------------------------------------------------------------------------------------------------------------------------------------------------------------------------------------------------------------------------------------------------------------------------------------------------------------------------------------------------------------------------------------------------------------------------------------------------------------------------------------------------------------------------------------------------------------------------------------------------------------------------------------------------------------------------------------------------------------------------------------------------------------------------------------------------------------------------------------------------------------------------------------------

			<p>change), and using the coefficient determined as appropriate based on the measured data for the amount of change of the potential at zero-current state and the amount of net coulomb charge charged/discharged, and the one-dimensional approximation function, the method approximates the amount of net coulomb charge charged/discharged from the calculated amount of change for the potential at zero-current state that was previously calculated.”; and “For example, by using the following formula decided on based on the measured data as the approximation function of the amount of change of the zero-current state potential and the amount of net coulomb charge charged/discharged for the rechargeable battery that is the object of measurement, the approximation of the amount of net coulomb charge charged/discharged (ΔQ_{ap}) in a rechargeable battery is calculated from the amount of change of the zero-current state potential (ΔV_{zero}) calculated before. $\Delta Q_{ap} = \kappa \times \Delta V_{zero} + \delta$ (κ and δ: Constants set in advance based on the measured data).”</p> <p>Based on this, it can be said that the description states that: “the zero-current state potential (V_{zero})” is the potential of the rechargeable battery when current is not flowing and is calculated by using a formula $V_{zero} = V_{ave} + R_{com} \times I_{ave}$ (V_{ave}: the average amount of voltage, I_{ave}: the average amount of current, R_{com}: the component resistance of the rechargeable battery; and that the net coulomb charge charged/discharged (ΔQ_{ap}) from the amount of change of the zero-current state potential (ΔV_{zero}) can be calculated by using a direct function, $\Delta Q_{ap} = \kappa \times \Delta V_{zero} + \delta$ (κ and δ: Constants set in advance based on the measured data).</p> <p>Therefore, when considering the description, in addition to the statement of the claim, the meaning of the above statement: “calculating the net coulomb charge charged/discharged (ΔQ_{ap}) of the rechargeable battery based on the amount of change (ΔV_{zero}) of the said zero-current state voltage (V_{zero})” can be specifically understood by persons skilled in the art.</p> <p>Based on the above, the claimed invention is clear.</p>
3.	<p>With respect to point a) the selected condition can be understood in the light of the description, but the examiner may question how the “selection” is being performed, which does not appear to be taught in the application as such, i.e. in what range is the test operating? In addition, the term “approximating” is very vague, and the skilled person will not know how close an approximation, and in which range he is operating.</p> <p>The wording: “selected current condition or selected voltage</p>	N/A	N/A

	<p>condition” can be understood by a skilled person of the field of batteries so that the wording can be considered clear as such. However with respect to novelty, this allows a large variety of conditions if found in the prior art to be used against the feature.</p> <p>Said wording is very general and is also included in a very general method step. This may lead to an objection from the EPO examiner under Article 84 EPC.</p> <p>The concerned method step is reproduced here below: “calculating the zero-current state potential (V_{zero}) from the potential across the terminals of the rechargeable battery when a selected current condition or a selected voltage condition is maintained for a predetermined period of time during the use of such rechargeable battery”.</p> <p>When assessing the clarity of such a broad method step the EPO examiner normally applies the instructions given in the EPO Guidelines in particular in sections F-IV 4.5.3 “Generalization of essential features” and F-IV 4.10 “Result to be achieved”. These instructions are derived from the European case law and applied and linked to the requirements of Article 84 EPC (Article 84 EPC reads: “The claims shall define the matter for which protection is sought. They shall be clear and concise and be supported by the description”).</p> <p>The concerned method step is a generalization of a methodology described in the description on page 4 last line to page 5, first paragraph (corresponds to fourth paragraph): “In this invention, the current terminal potential of the rechargeable battery are constantly measured at first. Then, the condition in which the measured current or the measured potential sustain a selected current condition or a selected voltage condition for a predetermined period of time is considered as a condition in which the said current and voltage have continuously stabilized for a predetermined period of time. Based on the average amount of the potential and current measured during the predetermined period of time and the component resistance of the rechargeable battery, the voltage of the rechargeable battery when current is not flowing, that is, the potential at zero-current state and the amount of its change is</p>		
--	--------------------------------------------------------------------------------------------------------------------------------------------------------------------------------------------------------------------------------------------------------------------------------------------------------------------------------------------------------------------------------------------------------------------------------------------------------------------------------------------------------------------------------------------------------------------------------------------------------------------------------------------------------------------------------------------------------------------------------------------------------------------------------------------------------------------------------------------------------------------------------------------------------------------------------------------------------------------------------------------------------------------------------------------------------------------------------------------------------------------------------------------------------------------------------------------------------------------------------------------------------------------------------------------------------------------------------------------------------------------------------------------------------------------------------------------------------------------------------------------------------------------------------------------------------------------------------------------------------------------------------------------------------------------------------------------------------------------------------------------------------------------------------------------------------------------------------------------------------------------------------------------------------------------------------------------------------------------------------------------------------------------------------------------------------------------------------------------------------------------------------------------------------------------------------------------------------------------------------------------------------------------------------------------------------------------------------------------	--	--

	<p>calculated.” and furthermore based on the specific example of the third paragraph on page 5 (corresponds to sixth paragraph) of the description: “More specifically, an example in which the conditions are “the current is less than 10A” for the said selected current condition, “the amount of change for the voltage is less than 1V” for the said selected voltage condition, and the said predetermined period of time is set at “10 seconds,” and consider the current condition (less than 10A) or the voltage condition (the amount of change is less than 1V) set is continuously satisfied for the said predetermined period of time (10 seconds) as the condition in which the current and voltage in a rechargeable battery is continuously stabilized for a predetermined period of time. Then, the zero-current state voltage (V_{zero}) is calculated by adding a value obtained by multiplying the average amount of voltage (I_{ave}) measured within the predetermined period of time by the component resistance (R_{com}) to an average value (V_{ave}) measured within the predetermined period of time (amending the voltage drop due to component resistance) ($V_{zero} = V_{ave} + R_{com} \times I_{ave}$.”</p> <p>Regarding the first aspect of “Generalization of essential features” EPO Guidelines set as a condition: “it is sufficient if the application as a whole describes the necessary characteristics of an invention in a degree of detail such that a person skilled in the art can perform the invention It is not necessary to include all details of the invention in the independent claim. Thus a certain degree of generalization of the claimed features may be permitted, provided that the claimed generalized features as a whole allow the problem to be solved. In this case a more specific definition of the features is not required. ...”</p> <p>In the present case the method step specifies in general terms the essential feature of how the zero-current state voltage is calculated. No objection is raised as to an excessive degree of generalization of the method step.</p> <p>However, a second check is performed by EPO examiner which is related to the aspect of: Is the invention defined in terms of a result to be achieved? More specifically the following</p>		
--	-----------------------------------------------------------------------------------------------------------------------------------------------------------------------------------------------------------------------------------------------------------------------------------------------------------------------------------------------------------------------------------------------------------------------------------------------------------------------------------------------------------------------------------------------------------------------------------------------------------------------------------------------------------------------------------------------------------------------------------------------------------------------------------------------------------------------------------------------------------------------------------------------------------------------------------------------------------------------------------------------------------------------------------------------------------------------------------------------------------------------------------------------------------------------------------------------------------------------------------------------------------------------------------------------------------------------------------------------------------------------------------------------------------------------------------------------------------------------------------------------------------------------------------------------------------------------------------------------------------------------------------------------------------------------------------------------------------------------------------------------------------------------------------------------------------------------------------------------------------------------------------------------------------------------------------------------------------------------------------------------------------------------------------------------------------------------------------------------------------------------------------------------------------------------------------------------------------------------------------------------------------------------------------------------------------------------------------------------------------------------------------------------------------------------	--	--

	<p>instructions are given to EPO examiners (Guidelines section F-IV 4.10):</p> <p>“The area defined by the invention must be as precise as the invention allows. As a general rule, claims which attempt to define the invention by a result to be achieved are not allowed, However, they may be allowed if the invention either can only be defined in such terms or cannot otherwise be defined more precisely without unduly restricting the scope of the claims and if the result is one which can be directly and positively verified by tests or procedures adequately specified in the description or known to the person skilled in the art and which do not require undue experimentation”.</p> <p>In the present case the EPO examiner would appreciate that in view of the description a more precise definition of the invention is possible without unduly restricting the scope of protection.</p> <p>In particular the expression “a selected current condition or a selected voltage condition for a predetermined period of time” is considered as <u>a condition in which the said current and voltage have continuously stabilized for a predetermined period of time</u>. Therefore the EPO examiner would likely suggest the addition of this definition (shown by underlining) in the claim to clarify the method step.</p> <p>Furthermore, the EPO examiner would likely consider that the method step does not clearly indicate <u>how the zero-current state voltage is calculated</u> and would possibly require the applicant to specify the actual equation provided in the description in the claim itself.</p> <p>.</p> <p>(b) With respect to point b), the claim defines “calculating the zero-current state voltage” but does not say that this step is repeated at a later time. As a result, an “amount of change of the said zero-current state voltage” is not clear, a single calculation does not allow to determine a change, as the reference point is not defined.</p> <p>In particular, in the phrase: “calculating the net coulomb charge charged/discharged (ΔQ_{ap}) of the rechargeable battery based on the amount of change (ΔV_{zero}) of the said zero-current state voltage (V_{zero})”.</p> <p>The EPO examiner would</p>		
--	------------------------------------------------------------------------------------------------------------------------------------------------------------------------------------------------------------------------------------------------------------------------------------------------------------------------------------------------------------------------------------------------------------------------------------------------------------------------------------------------------------------------------------------------------------------------------------------------------------------------------------------------------------------------------------------------------------------------------------------------------------------------------------------------------------------------------------------------------------------------------------------------------------------------------------------------------------------------------------------------------------------------------------------------------------------------------------------------------------------------------------------------------------------------------------------------------------------------------------------------------------------------------------------------------------------------------------------------------------------------------------------------------------------------------------------------------------------------------------------------------------------------------------------------------------------------------------------------------------------------------------------------------------------------------------------------------------------------------------------------------------------------------------------------------------------------------------------------------------------------------------------------------------------------------------------------------------------------------------------------------------------------------------------------------------------------------------------------------------------------------------------------------------------------------------------------------------------------------------------------------------------------------------------------------------------------------------------	--	--

	<p>consider that the step is defined in terms of result to be achieved. This type of definition raises the question: is the scope of the claim sufficiently clear?</p> <p>It is believed that the way the calculation is done in the description ($\Delta Q_{ap} = \kappa \times \Delta V_{zero} + \delta$ (κ and δ: Constants set in advance based on the measured data) is not straightforwardly clear to the skilled person. The skilled person reading the claim would wonder how the calculation is done – what data should be measured so the constants can be set in advance? The equation mentioned here above is further presented as an essential feature to solve the problem to be solved by the invention (accurately approximating the net coulomb charge charged/discharged in a rechargeable battery). As a conclusion, the second feature would therefore be considered as lacking clarity.</p>		
4.	Yes	Yes	Yes
5.	<p>The description puts the skilled person reading the claims and the description in the position to perform the invention using his general knowledge without undue burden.</p> <p>In this present case passages supporting all the claimed features in the sense of Article 84 EPC (claims shall be clear and supported by the description) can be found for all the claimed features. In the following the text of the claim and corresponding passages in the description are indicated in bold characters.</p> <p>1. A method for approximating the net coulomb charge charged/discharged in a rechargeable battery (support in the description: page 4, second paragraph from bottom (corresponds to third paragraph): “approximating the net coulomb charge charged/discharged in a rechargeable battery”), the method comprising the steps of:</p> <p style="padding-left: 40px;">calculating the zero-current state voltage (V_{zero}) from the terminal voltage of the rechargeable battery (support from the description: page 5, second paragraph from bottom (corresponds to sixth paragraph), last sentence: “Then, the zero-current state voltage (V_{zero}) is calculated... when a selected current condition or a selected</p>	<p>Whether the claim is supported by the description of the present invention is determined by whether a matter corresponding to the subject of the claim is stated in the description of the present invention, from the view point of the person skilled in the art. Rather than literal identical between the claims and the description of the invention, it should more closely be reviewed whether the claim refers to a subject which is beyond the scope of the description of the person skilled in the art. In this case, it is obvious for a person skilled in the art that features written in the claim are supported by the statements of the description.</p>	<p>As mentioned in the above Case Study 4, a claimed invention shall be disclosed in the description (Patent Act, Article 36 (6) (i)). The examiner examines a substantial correspondence between the claimed invention and the invention stated in the description. The consideration of the substantial correspondence done by the examiner is to examine whether or not the claimed invention exceeds “the extent of disclosure in the description to which a person skilled in the art would recognize that a problem to be solved by the invention would be actually solved.” (Examination Guidelines, Part II, Chapter 2, Section 2 “Support Requirement”, 2. “Determination of Support Requirement”)</p> <p>Here, it can be said that, based on the description, the problem to be solved by the claimed invention is to reduce the influence of measurement errors of the current and in approximating the charged/discharged amount of net coulomb charge, and to approximate the amount of net coulomb charge charged/discharged in a rechargeable battery more accurately.</p> <p>Also, the description includes: “the current terminal potential of the rechargeable battery are constantly measured at first. Then, the condition in which the measured current or the measured potential sustain a selected current condition or a selected voltage condition for a predetermined period of time is considered as a condition in which the said current and voltage have continuously stabilized for a determined period of time. Based on the average amount of the potential and current measured during the predetermined period of time and the component</p>

6.	<p>voltage condition is continuously satisfied for a predetermined period of time during the use of such rechargeable battery (support in the description: page 5, first paragraph (corresponds to fourth paragraph): "Then, the condition in which the current or the voltage measured continuously satisfy a selected current condition or a selected voltage condition for a predetermined period of time is considered as a condition in which the said current and voltage have continuously stabilized for a predetermined period of time...."; and calculating the net coulomb charge charged/discharged (ΔQ_{ap}) of the rechargeable battery based on the amount of change (ΔV_{zero}) of the said zero-current state voltage (V_{zero}) (support in the description: page 5 last paragraph to bottom of page 6 (corresponds to seventh paragraph): "the estimation of the net coulomb charge charged/discharged (ΔQ_{ap}) in a rechargeable battery is calculated from the amount of change of the zero-current state voltage (ΔV_{zero}) calculated before. $\Delta Q_{ap} = \kappa \times \Delta V_{zero} + \delta$ (κ and δ: Constants set in advance based on the measured data)".)</p>	N/A	<p>resistance of the rechargeable battery, the voltage of the rechargeable battery when current is not flowing, that is, the potential at zero-current state and the amount of its change are calculated."; and "As the present invention approximates the amount of net coulomb charge charged/discharged ΔQ_{ap} based on the function formula using the zero-current state voltage that is less influenced by measurement errors of the current, it has an effect of accurately approximating the amount of net coulomb charge charged/discharged in a rechargeable battery." Based on this, by taking into account the common general knowledge of the invention in the art, which is referred to in 2 stated above, persons skilled in the art are able to recognize that the above mentioned issue can be solved by a method for approximating the amount of net coulomb charge charged/discharged in a rechargeable battery by calculating the zero-current state potential that is less influenced by measurement errors of the current and based on the amount of change of the said potential at zero-current state, when a selected current condition or a selected voltage condition is maintained for a predetermined period of time during the use of the rechargeable battery. Also, Claim 1 of the invention contains the above mentioned means. Based on the above, the invention of Claim 1 meets the support requirement.</p>
6.	N/A	N/A	N/A

	CNIPA	USPTO
1.	No	Yes
2.	N/A	<p>(a) The invention of claim 1 meets the clarity requirement with regard to the recited "selected current condition or voltage condition." One skilled in the art would appreciate that this refers to a "predetermined" [i.e., arbitrary] current or voltage condition. The expression is merely broad. When read in light of the Description, one would understand "condition" to refer to a magnitude or to a degree of fluctuation in magnitude. The Description provides an illustrative example of each, to which the invention (as claimed) is clearly not limited.</p> <p>(b) The invention of claim 1 also meets the clarity requirement with regard to the statement "calculating the estimated amount of net coulomb charged/discharged (ΔQ_e) of the rechargeable battery based on the amount of change (ΔV_{zero}) of the said zero-current state potential (ΔV_{zero})." Although there is no antecedent basis or previous definition of "the amount of change (ΔV_{zero}) of the said zero-current state potential (ΔV_{zero})," one skilled in the art would understand that an amount of change in zero-current state potential (ΔV_{zero}) is to be found between a zero-current state potential (ΔV_{zero}) calculated at two arbitrary times. The expression is merely broad. The language, calculating the estimated amount of net coulomb charge charged/discharged (ΔQ_e) of the rechargeable battery "based on" this amount of change is also clear. One skilled in the art would understand that there is some established relationship between these two</p>

		variables, that permits one to be estimated based upon the other. The Description provides an illustration of one such relationship, to which the invention (as claimed) is clearly not limited.
3.	<p>The claims shall define the extent of the patent protection sought for in a clear and concise manner. (PATENT LAW OF THE PEOPLE'S REPUBLIC OF CHINA, Article 26.4)</p> <p>The clarity of the claims is of the utmost importance for the determination of the extent for which protection is sought by an invention or utility model. The requirement that the claims shall be clear means, on the one hand, individual claims shall be clear, and on the other hand, the claims as a whole shall be clear as well.</p> <p>A process claim is suitable for an invention of process, and shall usually be defined in terms of such technical features as technological process, operational conditions, steps, and procedures.</p> <p>The extent of protection as defined by each claim shall be clear. The extent of protection of a claim shall be construed according to the meaning of the words used in the claim. Generally, the words used in a claim shall be understood as having the meaning that they normally have in the relevant art. (GUIDELINES FOR PATENT EXAMINATION, Part II, Chapter 2, Section 3 "The Claims", 3.2.2 "Clarity")</p> <p>In Claim 1, the following features are explicitly recited: (a) "a selected current condition or voltage condition" (b) "calculating the net coulomb charge charged/discharged (ΔQ_{ap}) of the rechargeable battery based on the amount of change (ΔV_{zero}) of the said zero-current state voltage (V_{zero})".</p> <p>Regarding (a), as not been further defined, the technical feature of "a selected current condition or voltage condition" is ambiguous. The person skilled in the art cannot determine which current condition or voltage condition the feature "a selected current condition or a specific voltage condition" is intended to define. The person skilled in the art cannot distinguish between the extent of the selected current condition or voltage condition and the extent of other current conditions or voltage conditions which are not selected. Therefore, from the feature "calculating the zero-current state potential (V_{zero}) from the potential across the terminals of the rechargeable battery when a selected current condition or a selected voltage condition is maintained for a predetermined period of time during the use of such rechargeable battery" in claim 1, the person skilled in the art cannot clearly determine the condition under which the zero-current state potential (V_{zero}) shall be calculated from the potential across the terminals of the rechargeable battery.</p> <p>Furthermore, according to the description, the technical feature related to the condition under which the zero-current state potential (V_{zero}) shall be calculated from the potential across the terminals of the rechargeable battery is essential for solving the technical problem to be solved by the invention. Therefore, the feature "selected current condition or voltage condition" makes the extent of protection in claim 1 unclear.</p> <p>Regarding (b), it is apparent that "the zero-current state voltage (V_{zero})", "the net coulomb charge charged/discharged (ΔQ_{ap})", and "the change (ΔV_{zero}) of the said zero-current state voltage (V_{zero})" have the meanings that they normally have in the relevant art. The person skilled in the art can understand that "calculating the net coulomb charge charged/discharged (ΔQ_{ap}) of the rechargeable battery based on the amount of change (ΔV_{zero}) of the said zero-current state voltage (V_{zero})" means calculating ΔQ_e from ΔV_{zero} by using any method or formula well known in the prior art.</p>	N/A

	<p>Therefore, the meaning of “calculating the net coulomb charge charged/discharged (ΔQ_{ap}) of the rechargeable battery based on the amount of change (ΔV_{zero}) of the said zero-current state voltage (V_{zero})” is apparent to persons skilled in the art. The feature (b) in claim 1 is permissible.</p> <p>To sum up, because the feature (a) makes the extent of protection in claim 1 unclear, claim 1 does not meet the clarity requirement.</p>	
4.	<p>Yes, If the above mentioned defect has been overcome by adding to claim 1 the technical feature related to the condition disclosed in the description, such as “the condition in which the measured current or the measured potential sustain a selected current condition or a selected voltage condition for a predetermined period of time being a condition in which the said current and voltage have continuously stabilized for a determined period of time”.</p>	No
5.	<p>The claims shall be supported by the description. (PATENT LAW OF THE PEOPLE’S REPUBLIC OF CHINA, Article 26.4)</p> <p>“The claims shall be supported by the description” means that the technical solution for which protection is sought in each of the claims shall be a solution that a person skilled in the art can reach directly or by generalization from the contents sufficiently disclosed in the description, and shall not go beyond the scope of the contents disclosed in the description.</p> <p>Claims are usually generalizations from one or more embodiments or examples as set forth in the description. The generalization of a claim shall not go beyond the scope of the contents disclosed in the description. If the person skilled in the art can reasonably predict that all the equivalents or obvious variants of the embodiments set forth in the description have the same properties or uses, then the applicant shall be allowed to generalize the protection extent of the claim to cover all the equivalents or obvious variants. In determining whether the generalization of a claim is appropriate, the examiner shall refer to the relevant prior art.</p> <p>For claims generalized in generic terms or by parallel options, the examiner shall examine whether the generalization can be supported by the description. Where the generalization of a claim includes contents speculated by the applicant and the effect thereof is difficult to determine or evaluate beforehand, the generalization shall be regarded as going beyond the scope of the contents disclosed in the description. If the generalization of a claim is such that the person skilled in the art can reasonably doubt that one or more specific terms or options included in the generic terms or parallel options cannot solve the technical problem aimed to be solved by the invention or utility model and achieve the same technical effects, then it shall be taken that the claim is not supported by the description. In these cases, the examiner shall raise an objection of lack of support on the ground of Article 26.4 and invite the applicant to amend the claim.</p> <p>As for a broadly generalized claim relating to the whole class of products or machines, if it is fairly supported by the description, and there is no reason to suppose that the invention or utility model cannot be worked through the whole of the field claimed, then the claim may be acceptable even if its extent of protection is broad. However, if the information given in the description is insufficient to enable a person skilled in the art to extend the teaching of the description to the extent of protection claimed in the claim by using routine methods of experimentation or analysis, the examiner shall invite the applicant to explain and establish that a person skilled in the art can readily extend the invention or utility model to the extent of protection claimed in the claim on the basis of the information given in the description; otherwise, the</p>	N/A

	<p>examiner shall invite the applicant to restrict the claim. (GUIDELINES FOR PATENT EXAMINATION, Part II, Chapter 2, Section 3 “The Claims”, 3.2.1 “Support in the Description”)</p> <p>In Claim 1, the following features are explicitly recited: (a) “a selected current condition or voltage condition” (b) “calculating the net coulomb charge charged/discharged (ΔQ_{ap}) of the rechargeable battery based on the amount of change (ΔV_{zero}) of the said zero-current state voltage (V_{zero})”</p> <p>Because the feature (a) is ambiguous, it isn’t taken into account in the discussion below, and the discussion is under the presumption that the above mentioned defect has been overcome by adding to claim 1 the technical feature related to the condition disclosed in the description, such as “the condition in which the measured current or the measured potential sustain a selected current condition or a selected voltage condition for a predetermined period of time being a condition in which the said current and voltage have continuously stabilized for a determined period of time”.</p> <p>Based on the description, the problem to be solved by the invention is to reduce the influence of measurement errors of the current and in approximating the charged/discharged amount of net coulomb charge, and to approximate the amount of net coulomb charge charged/discharged in a rechargeable battery more accurately.</p> <p>As a means to solve the above mentioned problem, the description contains the following means: “the current terminal potential of the rechargeable battery are constantly measured at first. Then, the condition in which the measured current or the measured potential sustain a selected current condition or a selected voltage condition for a predetermined period of time is considered as a condition in which the said current and voltage have continuously stabilized for a determined period of time. Based on the average amount of the potential and current measured during the predetermined period of time and the component resistance of the rechargeable battery, the voltage of the rechargeable battery when current is not flowing, that is, the potential at zero-current state and the amount of its change are calculated”, “based on the correlation between the amount of change of the current and the amount of net coulomb charge charged/discharged (the closer to full charge, the smaller the temporal change), and using the coefficient determined as appropriate based on the measured data for the amount of change of the potential at zero-current state and the amount of net coulomb charge charged/discharged, and the one-dimensional approximation function, the method approximates the amount of net coulomb charge charged/discharged from the calculated amount of change for the potential at zero-current state that was previously calculated”.</p> <p>Regarding (b), the person skilled in the art can understand that the above feature (b) in claim 1 means calculating ΔQ_{ap} from ΔV_{zero} by using any method or formula well known in the prior art.</p> <p>The description states the followings: “As the present invention approximates the amount of net coulomb charge charged/discharged ΔQ_{ap} based on the function formula using the zero-current state voltage that is less influenced by measurement errors of the current, it has an effect of accurately approximating the amount of net coulomb charge charged/discharged in a rechargeable battery”, “For example, by using the following formula decided on based on the measured data as the approximation function of the amount of change of the zero-current state potential and the amount of net coulomb charge charged/discharged for the rechargeable battery that is the object of measurement, the approximation of the amount of net</p>	
--	--------------------------------------------------------------------------------------------------------------------------------------------------------------------------------------------------------------------------------------------------------------------------------------------------------------------------------------------------------------------------------------------------------------------------------------------------------------------------------------------------------------------------------------------------------------------------------------------------------------------------------------------------------------------------------------------------------------------------------------------------------------------------------------------------------------------------------------------------------------------------------------------------------------------------------------------------------------------------------------------------------------------------------------------------------------------------------------------------------------------------------------------------------------------------------------------------------------------------------------------------------------------------------------------------------------------------------------------------------------------------------------------------------------------------------------------------------------------------------------------------------------------------------------------------------------------------------------------------------------------------------------------------------------------------------------------------------------------------------------------------------------------------------------------------------------------------------------------------------------------------------------------------------------------------------------------------------------------------------------------------------------------------------------------------------------------------------------------------------------------------------------------------------------------------------------------------------------------------------------------------------------------------------------------------------------------------------------------------------------------------------------------------------------------------------------------------------------------------------------------------------------------------------------------------------------------------------------------------------------------------------------------------------------------------------------------------------------------------------------------------------------------------------------------------------------------------------------------------------------------------------------------------------------------------------------------------------------------------------------------------------------------------------------------------------------------------------------------------------------------------------------------------------------------------------------------------------------------------------------------------------------------------------------------------------------------------------------------------------------------------------------------------------------------------------------------------------------------------------------------------------------------------------------------------------------------------------------------------------------------------------------------------------------------------------------------------------------------------------------------------------------------------------------------------------------------------------------------------------------------------------------------------------------------------------------------------------------------------------------------------------------------------------------------------------------------------------	--

	<p>coulomb charge charged/discharged (ΔQ_{ap}) in a rechargeable battery is calculated from the amount of change of the zero-current state potential (ΔV_{zero}) calculated before. $\Delta Q_{ap} = \kappa \times \Delta V_{zero} + \delta$ (κ and δ: Constants set in advance based on the measured data)".</p> <p>The means to calculate ΔQ_{ap} from ΔV_{zero} is also well known in the prior art.</p> <p>Based on the description and the common general knowledge in the art, the person skilled in the art can reasonably predict that all methods and formula disclosed in the description and in the prior art that are capable of calculating ΔQ_{ap} from ΔV_{zero} can solve substantially the same technical problem and achieve substantially the same expected effects. Definition by the feature (b) in claim 1 does not embrace the means which is incapable of solving the technical problem aimed to be solved by the invention. Then the feature (b) in claim 1 can be allowed.</p> <p>To sum up, the definition by the feature (b) is permissible, and thus claim 1 meets the support requirement.</p>	
6.	N/A	<p>The claimed does not satisfy the written description requirement, because the disclosure does not demonstrate that, at the time the invention was filed, Applicant was actually in possession of the claimed invention (that is, that the invention was "ready for patenting"). The unsupported subject matter is the step of "calculating the estimated amount of net coulomb charge charged/discharged (ΔQ_e) of the rechargeable battery based on the amount of change (ΔV_{zero}) of the said zero-current state potential (ΔV_{zero})."</p> <p>Neither the claim nor the Description describe how to calculate the amount of change (ΔV_{zero}) of the said zero-current state potential (ΔV_{zero}) of the "battery that is the object of the measurement. "</p> <p>In the Description, a battery [or representative battery] is characterized in advance by constantly measuring the current and voltage ("constantly measured at first"). It appears that the zero-current state potential (ΔV_{zero}) [open-circuit voltage] is directly measured at various intervals whereby the relationship $\Delta Q_{ap} = \kappa \times \Delta V_{zero} + \delta$ can be determined in advance ("κ and δ: Constants set in advance based on the measured data").</p> <p>But in finding (ΔV_{zero}) of the battery that is the object of the estimation, the only disclosure of the zero-current state potential (ΔV_{zero}) is one that is "calculated by adding a value obtained by multiplying the average amount of voltage [sic, current] (I_{ave}) measured within the certain period of time by the component resistance (R_{com}) to an average value (V_{ave}) measured within the certain period of time (amending the voltage drop due to component resistance) ($\Delta V_{zero} = V_{ave} + R_{com} \times I_{ave}$).</p> <p>Since the ($\Delta V_{zero}$) calculation relies on voltage and current averaged over the "certain period of time", it cannot be inferred that an "amount of change (ΔV_{zo}) of the said zero-current state potential (ΔV_{zero})" is to be found from (ΔV_{zero}) calculated at the endpoints of the "certain period of time." [Both calculations would rely on the same averages and yield the same the zero-current state voltage (ΔV_{zero}), such that the difference (ΔV_{zero}) would be zero].</p> <p>Based on the foregoing, the amount of change (ΔV_{zero}) of the said zero-current state potential (ΔV_{zero}) of the battery that is the object of the estimation method must be found as the difference between the (ΔV_{zero}) calculated over the "certain time period" and some other said zero-current state potential (ΔV_{zero}). The Description does not say what other (ΔV_{zero}) is to be used in finding this difference. As such, the Description does not demonstrate that, at the time the invention was filed, Applicant knew what other (ΔV_{zero}) was to be used in carrying out the method. Not even one embodiment is described. It is not clear whether Applicant was in possession of estimating the total charge used, the charge remaining, only the charge used between two intervals satisfying the specific current or voltage condition.</p>

Case 6

	EPO	KIPO	JPO
1.	No	No	No
2.	N/A	N/A	N/A
3.	<p>The mere listing of structural elements without any definition of the interrelation and arrangements in which the parts are put into working with each other does not allow the skilled person to understand how the device is put into working. Any technical effect is not apparent from the features alone, but requires that the structural relationships be defined. In this case, the structural relationship between the elements in the claim is not defined.</p> <p>So although an applicant is in principle allowed to draft a claim in the form of a list of structural features, present claim 1 is not clear, for the following reasons:</p> <p>The text of the claim is reproduced here below:</p> <p>2. "1. A stamping device comprising: stamp blocks having stamps on upper surfaces thereof; stamp units for stamping a date; grooves; a case; and a base."</p> <p>Section F-IV 4.1 of the European Guidelines for examination indicates that: "... the meaning of the terms of a claims must, as far as possible, be clear for the person skilled in the art from the wording of the claim alone".</p> <p>The terms used in the claim are, when taken individually clear in the sense that they have a technical meaning which can be identified and understood by the skilled person.</p> <p>However, the present "list" format claim including very little or no information on the function of particular feature e.g. "grooves" renders the claim difficult to interpret. The scope of the claim is therefore rather vague. A vague scope would lead to an objection of lack of clarity of the claim.</p> <p>EPO examiners are requested to object to a claim when essential features are missing in a claim: "The claims which define the matter for which protection is sought must be clear, meaning not only that a claim must be comprehensible from a technical point of view, but also that it must define clearly all the</p>	<p>Claim 1 does not establish a stamping device, a stamp unit, grooves, a systematic connection between a case and a base or working processes, but simply lists each component of which the claimed invention is consisting. Therefore, it shall be determined that the person skilled in the art cannot arrive at the present invention 'the input device with which a date is inserted in the business card' based on the concerned description. Therefore, it can be determined that the scope of the claim as above mentioned is unclear pursuant to Article 42(4)(ii) of the Patent Act of Korea.</p>	<p>As mentioned in the above Case Study 4, in order to meet the clarity requirement, the scope of the claimed inventions shall be clear and also, since an invention for which a patent is sought is described on a claim-by-claim basis, one invention should be identified based on matters stated in one claim. (Examination Guidelines, Part II, Chapter 2, Section 3 "Clarity Requirement", 2.1 "Basic ideas of determination of clarity requirement"). Based on this, for example, even though taking into account the statements of the description and the common general knowledge of the inventions in the art as of the time of the filing, the claimed inventions are considered to be a violation of clarity requirement, in cases when: (1) the technical meaning of a matter specifying the invention, i.e. the function or role that these elements play in the claimed invention, is incomprehensible to a person skilled in the art ; and (2) it is evident that the matter specifying the invention is deficient in light of the common general knowledge as of the filing. (Examination Guidelines, Part II, Chapter 2, Section 3 "Clarity Requirement", 2.2 "Types of violation of clarity requirement")</p> <p>In Claim 1, when looking at the descriptions of "stamp block having stamps on upper surfaces thereof," "stamp units for stamping dates," "grooves," "a case," and "a base," no structural relationship between each of them is stated. Based on this, even though taking into account the statement of the description and the drawings as well as the common general knowledge in the art, the technical meaning of a matter specifying the invention, i.e. the function or role that these elements play in the invention of Claim 1, is incomprehensible to a person skilled in the art.</p> <p>Furthermore, in the case of inventions that are stamping devices, it is common general knowledge in the art that the structural relationship between each of the parts differs significantly depending on the technical meaning of each part. When considering this common general knowledge, it is evident that the matters are deficient for persons skilled in the art to understand the structural relationship among each of the above-mentioned matters. Therefore, the invention cannot be clearly identified from the statement of Claim 1.</p> <p>Also, since the statement of the description and drawings include the specific modes for carrying out the structural relationship among each of the above-mentioned matters, persons skilled in the art can understand the roles performed by the above-mentioned matters in these specific modes for</p>

	<p>essential features of the invention Furthermore, the requirement of Art. 84 that the claims be supported by the description applies to features which are explicitly presented in the description as being essential for carrying out the invention. ... A lack of essential features in the independent claim(s) is therefore to be dealt with under the clarity and support requirements" (EPO Guidelines section F-IV 4.5.1).</p> <p>Starting from this approach and in view of the problem to be solved as given in the description:</p> <p>"A problem to be solved by the invention is to provide a stamping device suited for printing dates on business cards stored inside a business-card case.", it would appear that at least the feature of the description related to the groove and its technical relationship with the stamp units, namely: "When setting dates, users change each of the stamp units in the stamp case accordingly with their fingers or by using a tool such as tweezers. <u>They slide the stamp blocks in the grooves to arrange dates by year, a month, and a day</u>" is an essential feature of the invention. The EPO examiner would therefore likely object to this and invite the applicant to amend the claim based on the underlined feature.</p> <p>Moreover, there is not mentioned any printing substance (for example ink) that is applied to the card to make the date visible on the business card; it is not clear how the ink is applied to the stamps in order to transfer the ink from the stamps onto the business card afterwards</p>		<p>carrying out the structural relationship. However, in Claim 1, no structural relationships are stated, and as a result, the roles performed by these matters in the invention of Claim 1 cannot be interpreted in such a restrictive way as in the description. Therefore, even though taking into account the statement of the description and the drawings, persons skilled in the art are not able to understand the technical meanings of these matters from the statement of Claim 1.</p> <p>Based on the above, the invention of Claim 1 does not meet the clarity requirement.</p>
4.	No	Yes	No
5.	N/A	<p>Whether the claim is supported by the description of the present invention is determined by whether a matter corresponding to the subject of the claim is stated in the description of the present invention, from the view point of the person skilled in the art. Rather than literal identical between the claims and the description of the invention, it should more closely be reviewed whether the claim refers to a subject which is beyond the scope of the description of the invention, from the perspective of the person skilled in the art. In case of the above claim, even though a detailed description of the invention states the composition and the working principle with</p>	N/A

		<p>respect to 'a stamping device to stamp the date into a business card', it is determined that to embody a stamping device of the claim based on a detailed description of the invention has neither generalized nor extended beyond the scope of the description of the invention from the view point of the person skilled in the art, and that the person skilled in the art can understand the composition of and the working effect of the subject of the claim. Therefore, the above claim is determined to be supported by a detailed description of the invention.</p>	
6.	<p>Even if all the features of claim 1 find a support in the description, the claim is however not supported by the description because essential feature(s) for solving the problem to be solved as expressed in the description are missing in the claim, i.e. the description is teaching a different set of essential features to the claim and so does not support it in the sense of Article 84 EPC.</p> <p>Specifically at least the relationship between the grooves and the stamp units for setting a date should be mentioned in the claim (relevant passage of the description: "When setting dates, users change each of the stamp units in the stamp case accordingly with their fingers or by using a tool such as tweezers. They slide the stamp blocks in the grooves to arrange dates by year, a month, and a day, as shown in Figure 3, in order to position them on the above-mentioned stamp bases." (See description page 7, last paragraph (corresponds to fourth paragraph)) and "Also, stamp units for printing dates are inserted into grooves that are formed concentrically in the stamp case" (description, page 7, first paragraph (corresponds to second paragraph)).</p> <p>It is also noted that it is not disclosed in the whole text how printing substance (for example ink) is applied to the stamps in order to transfer the printing substance from the types to the business card afterwards. This might even be considered a contravention of Article 83 EPC, depending on the person skilled in the art – i.e. if said person would interpret "stamp base" as meaning a self-inking device.</p>	N/A	<p>As mentioned in the above Case Study 4, a claimed invention shall be disclosed in the description (Patent Act, Article 36 (6) (i)). The examiner examines a substantial correspondence between the claimed invention and the invention stated in the description. The consideration of the substantial correspondence done by the examiner is to examine whether or not the claimed invention exceeds "the extent of disclosure in the description to which a person skilled in the art would recognize that a problem to be solved by the invention would be actually solved." (Examination Guidelines, Part II, Chapter 2, Section 2 "Support Requirement", 2. "Determination of Support Requirement")</p> <p>Here, it can be said that, based on the statement of the description, the problem to be solved by the claimed invention is to provide a stamping device suitable for stamping dates on business cards stored in a business-card case. As a means to solve the above-mentioned problem, the description and the drawings state a stamping device comprising: stamp units for stamping dates which have connecting structures so that plural stamp blocks having stamps on upper surfaces thereof are connected and can move up and down (in order for the stamp blocks to be positioned for stamping dates); a case in which a number of the above-mentioned stamp units are inserted into grooves that are formed concentrically in the case; and a set of bases fixed in a predetermined position in the grooves formed in the above mentioned case, in order to position the above mentioned stamp blocks for setting dates, which are positioned higher than other stamp blocks. (See Figures 1 to 3 and the description on these drawings)</p> <p>However, it is recognized that Claim 1 does not include any statement of means to solve the above-mentioned problem, including the structural relationship among "stamp block having stamps on upper surfaces thereof," "stamp units for stamping dates," "grooves," "a case," and "a base" of the stamping device.</p> <p>Based on this, the invention of Claim 1 exceeds the extent of the disclosure in</p>

			the description and drawings of the claimed invention. Therefore, the invention of Claim 1 does not meet the support requirement.
--	--	--	--------------------------------------------------------------------------------------------------------------------------------------

	CNIPA	USPTO
1.	Yes	No
2.	<p>According to Patent Law, Article 26.4, the claims shall define clearly and concisely the matter for which protection is sought in terms of the technical features of the invention. Since the claims are used for the basis of determination of the scope for which protection is sought for by an invention, the statement in the claims has great significance.</p> <p>According to the Article, the requirement that the claims shall be clear means, on one hand, individual claims shall be clear, and on the other hand, the claims as a whole shall be clear as well.</p> <p>2.1 individual claims shall be clear Based on this, it is necessary that the category of each claim shall be clear and the scope of protection as defined by each claim shall be clear. The scope of protection of a claim shall be construed according to the meaning of the words used in the claim. Generally, the words used in a claim shall be understood as having the meaning which they normally have in the relevant art. And any terms which meaning is indefinite shall not be used in a claim, unless such terms have a well-recognized definite meaning in the particular art. Also, generally, such terms as "about", "approximately", "etc." and the like shall not be used in a claim, since they are likely to make the scope of the claim unclear.</p> <p>2.2 claims as a whole shall be clear This means that the reference relations between the claims shall be clear. The additional technical feature of a dependent claim should be a feature that further defines the technical features of the claim on which it depends, or may be a feature newly introduced. And the technical features which further defined by the dependent claim must be stated in the claim on which the dependent claim depends.</p> <p>2.3 about this case In claim 1, the subject matter indicates clearly that this is a product claim. And in this product claim, the features such as "stamp block", "stamp unit", "grooves", "case", and " base" which be used to define the product "stamping device" are structural features. A person skilled in the art can understand the category of claim 1, and the main components of the stamping device defined in claim 1.</p> <p>The technical features used in claim 1 all have definite meaning in the art, and they will not define different scope of protection in claim 1 or make the scope of claim 1 unclear.</p> <p>Finally, in the case of a stamping device, it is common general knowledge in the art that the structural relationship between each of the parts, a person skilled in the art would understand know the possible relationship among those parts stated in the claim 1. Based on the above, the invention claim 1 is clear and meets the clarity requirement under Article 26.4.</p>	N/A
3.	N/A	<p>Claim 1 does not meet the clarity requirement.</p> <p>Upon review of claim 1, the only material set forth is a "listing" of components – 1) stamp blocks having numerical characters on the upper surfaces thereof; 2) stamp units for stamping a date; 3) grooves; 4) a case and 5) a base. No structural relationship/interconnection is set forth for any of the components. Looking at the claim, one of ordinary skill in the art would not comprehend how these components cooperate together to result in a "stamping device". Figures 1-3 and the description (lines 3-18) set forth the working</p>

		relationship between the individual components to provide a working stamp device that can accomplish the desired result (solution to the problem being solved). However, claim 1 provides no additional language concerning the relationship between any of the components and one of ordinary skill would not be held to the exact language of the specification when interpreting the claim language (the claim is simply interpreted as presently set forth). Even given the general knowledge of these common components in print devices, claim 1 gives no guidance whatsoever as to how these components work/function together to accomplish the desired result (these components may be arranged in various configurations in similar devices). In summary, the clarity requirement concerning claim 1 has not been met.
4.	No	No
5.	N/A	N/A
6.	<p>The claims shall be supported by the description and shall define clearly and concisely the extent of the patent protection asked for (Patent Law, Article 26.4). That the claims shall be based on the description means that the claims shall be supported by the description. The technical solution for which protection is sought in each of the claims shall be a solution that a person skilled in the art can reach directly or by generalization from the contents sufficiently disclosed in the description, and shall not go beyond the scope of the contents disclosed in the description.</p> <p>When the person skilled in the art can reasonably predict that the equivalents or obvious variants of the embodiments set forth in the description have the same properties or uses, then the applicant shall be allowed to generalize the protection scope of the claim to cover all the equivalents or obvious variants. If the generalization of the claim is such that the person skilled in the art can reasonably doubt that one or more specific terms or options included in the generic terms or parallel options cannot solve the technical problem aimed to be solved by the invention and achieve the same technical effects, then it shall be taken that the claim is not supported by the description.</p> <p>In this case, claim 1 states a stamping device comprising: stamp blocks having stamps on upper surfaces thereof, stamp units for stamping a date, grooves, a case, and a base. While according to statement of the description, the problem to be solved by the claimed invention is to provide a stamping device suitable for stamping dates on business cards stored in a business-card case. As a means to solve the above-mentioned problem, the description and the drawings state a stamping device comprising: stamp units for stamping dates which have connecting structures so that plural stamp blocks having stamps on upper surfaces thereof are connected and can move up and down (in order for the stamp blocks to be positioned for printing dates); a case in which a number of the above-mentioned stamp units is inserted into grooves that are formed concentrically in the case; and a set of bases fixed in a predetermined position in the grooves formed in the above mentioned case, in order to position the above mentioned stamp blocks for setting dates, which are positioned higher than other stamp blocks. (See Figures 1 to 3 and the description on these drawings). And a person skilled in the art can recognize that some other connecting relationships cannot solve the problem. Based on the above, the scope of claim 1 is too broad to be supported by the description of the invention. Therefore, the invention of claim 1 does not meet the support requirement.</p>	<p>Claim 1 does not meet the support requirement.</p> <p>As noted previously, Figures 1-3 and the description (lines 3-18) set forth an operable embodiment of the stamp device. The structural relationship between the 5 major components (listed above) are set forth to provide a complete working device. However, since claim 1 does not include any of the structural relationship between the components, the claim encompasses more than the description can support. The open-ended language of the claim (just a listing of components) provides for multiple possible variations of the device, which would not be considered as being supported by the description. In addition, claim 1 does not include/provide for a solution/means to solve the problem at hand. The simple listing of components do not provide for a device to accomplish the stated solution. In summary, the support requirement concerning claim 1 has not been met.</p>

5. Analysis on IP5 Offices' Case Studies

Overview

- Do the claimed inventions meet the clarity requirements?

	EPO	JPO	KIPO	CNIPA	USPTO
Case 4	Yes	Yes	Yes	Yes	Yes
Case 5	No	Yes	Yes	No	Yes
Case 6	No	No	No	Yes	No

- Do the claimed inventions meet the support requirements?

	EPO	JPO	KIPO	CNIPA	USPTO
Case 4	Yes	Yes	Yes	Yes	Yes
Case 5	Yes	Yes	Yes	Yes	No
Case 6	No	No	Yes	No	No

- As for Case 4, the results of the IP5 Offices were the same.
- As for Case 5, the results were different among the IP5 Offices. Some offices determined the claimed invention of Case 5 meets both of the clarity requirements and the support requirements while the other offices determined it does not meet at least one of the clarity requirements and the support requirements.
- As for Case 6, all the IP5 offices determined the claimed invention of Case 6 does not meet at least one of the clarity requirements and the support requirements.

- Case Study 4

- (1) Summary of the results

All of the IP5 Offices determined that the claimed invention in Case Study 4 meets the clarity requirements and the support requirements.

- (2) Comparative study on ways of examinations at the IP5 Offices

- (i) Term to be examined

IP5 Offices considered if the invention of Claim 1 is unclear because of the statement “means for ...” (*) or not?

- (ii) Way of thinking on applicable criteria regarding the clarity requirements

The EPO determined the ‘means for’ formulation is well established in the Computer Implemented Inventions field. Regarding the first functional feature, namely: “touch detection means (31) for determining whether or not a touch has occurred in a predetermined area where no keys of the keyboard layout (15) are displayed on the touch screen (12)”, this feature is considered to be clear as the skilled person of the human machine interface, more specifically of the field of smart phones or tablets with touch screen would know how to design such “touch detection means”. The man skilled in the art should have no difficulty in providing some means of performing the function without exercising inventive skill. The same applies to the second functional feature. The skilled person would easily understand the function of the display switching control means and how to design such a keyboard changing means to perform said function.

The JPO determined “touch detection means (31) for determining...” is considered to be means which persons skilled in the art can understand, by taking into account the statement of the claim and the common general knowledge of the invention in the art, as a means designed to determine that “a touch has occurred,” when “a touch has occurred in a predetermined area where no keys of the keyboard layout (15) are displayed on the touch screen (12).” Also, the JPO determined “keyboard changing means (33) for changing...” is considered to be means which persons skilled in the art can understand, by taking into account the statement of the claim and the common general knowledge of the invention in the art. That is, the persons can understand this as a means designed to change the keyboard layout, i.e. “change a keyboard layout displayed on the touch screen to another keyboard layout stored in the memory,” when “the detection means (31) determines that a touch has occurred.”

The KIPO determined in case of the claim, as the person skilled in the art could clearly understand the claimed subject-matter and the statement “means for...”, taking into account a detailed description or drawing(s), it can be determined that the concerned claim satisfies the requirement of Article 42(4)(ii) of the Patent Act of Korea.

The CNIPA determined the technical feature of “touch detection means” defined by function in claim 1 shall be construed as embracing all the means that are capable of performing the function of “determining whether or not a touch has occurred in a predetermined area where no keys of the keyboard layout are displayed on the touch screen”. Therefore, by taking into account the statement of the claim and the common general knowledge in the art, what “touch detection means for determining...” exactly means can be clearly understood by persons skilled in the art. Regarding (2), the technical feature of “keyboard changing means” defined by function in claim 1 shall be construed as

embracing all the means that are capable of performing the function of “changing a keyboard layout displayed on the touch screen to another keyboard layout stored in the memory unit when the touch detection means determines that a touch has occurred in the predetermined area”. Therefore, by taking into account the statement of the claim and the common general knowledge in the art, what “keyboard changing means for changing...” exactly means can be clearly understood by persons skilled in the art.

The USPTO determined in this case, the structure corresponding to a 35 U.S.C. 112(f) claim limitation for a computer-implemented function must include the algorithm needed to transform the general purpose computer or microprocessor disclosed in the specification. One skilled in the art would know how to program a processor to perform the steps described in the specification for touch detection means and keyboard changing unit. There is sufficient description of how to transform the general-purpose CPU into a special-purpose CPU to perform the claimed functions.

(iii) Way of thinking on applicable criteria regarding the support requirements
In the EPO, examiners compare the text of the claims with that of the description and detect for instance possible mismatch or inconsistencies. Examiners also check that claims are not broader than is justified by the extent of the description and drawings and also to the contribution to the art. In the present case all the features specified in the claim and their respective function do have a basis in the description.

In the JPO, the examiner examines a substantial correspondence between the claimed invention and the invention stated in the description to determine whether the support requirement is met. By taking into account the common general knowledge of the invention in the art, persons skilled in the art would recognize that the problem can be solved by touch detection means, such as the touch detection unit, and keyboard changing means, such as the keyboard changing unit.

In the KIPO, whether the claim is supported by the description of the present invention is determined by whether a matter corresponding to the subject of the claim is stated in the description of the present invention, from the view point of the person skilled in the art. In this case, it is obvious for a person skilled in the art that features written in the claim are supported by the statements of the description.

In the CNIPA, for claim containing a feature defined by function, whether the definition by function can be supported by the description shall be examined. Based on the description and the common general knowledge in the art, the person skilled in the art can reasonably predict that all the equivalents or obvious variants of the embodiments set forth in the description have the same properties or uses.

In the USPTO, when examining computer-implemented functional claims, examiners should determine whether the specification discloses the computer and the algorithm (e.g., the necessary steps and/or flowcharts) that perform the claimed function in sufficient detail such that one of ordinary skill in the art can reasonably conclude that the inventor invented the claimed subject matter. In this case, one of ordinary skill in the art would be able to make and use the invention, e.g. by programming a computer to perform the claimed functions. The best mode is determined to detect a touch on an area where no keys of a keyboard layout are displayed.

2. Case Study 5

(1) Summary of the results

With regard to the clarity requirements, the JPO, the KIPO and the USPTO determined the claimed invention in Case Study 5 meets the requirements while the EPO and the CNIPA determined it does not meet the requirements. Also, with regard to the support requirements, the EPO, the JPO, the KIPO and the CNIPA determined the claimed invention in Case Study 5 meets the requirements while the USPTO does not meet the requirements.

(2) Comparative study on ways of examinations at the IP5 Offices

(i) Term to be examined

IP5 Offices considered if (a) the invention of Claim 1 is unclear because of the statement “selected current condition or voltage condition” or not and (b) the invention of Claim 1 is unclear because of the statement “calculating the approximate amount of net coulomb charge charged/discharged (ΔQ_{ap}) of the rechargeable battery based on the amount of change (ΔV_{zero}) of the said zero-current state potential voltage (V_{zero})” or not?

(ii) Way of thinking on applicable criteria regarding the clarity requirements

The EPO determined with respect to point a) the selected condition can be understood in the light of the description, but the examiner may question how the “selection” is being performed, which does not appear to be taught in the application as such, i.e. in what range is the test operating? In addition, the term “approximating” is very vague, and the skilled person will not know how close an approximation, and in which range he is operating. Also, the examiner checks whether the invention is defined in terms of a result to be achieved or not. In the present case the EPO examiner would appreciate that in view of the description a more precise definition of the invention is possible without unduly restricting the scope of protection. With respect to point b), the claim defines “calculating the zero-current state voltage” but does not say that this step is repeated at a later time. As a result, an “amount of change of the said zero-current state voltage” is not clear, a single calculation does not allow to determine a change, as the reference point is not defined. It is believed that the way the calculation is done in the description is not straightforwardly clear to the skilled person. The skilled person reading the claim would wonder how the calculation is done. Because the equation mentioned here above is further presented as an essential feature to solve the problem to be solved by the invention, the second feature would therefore be considered as lacking clarity.

The JPO determined regarding (a), from the statement in the claim “calculating the zero-current state potential (V_{zero}) across the terminals of the rechargeable battery when a selected current condition or a selected voltage condition is maintained for a predetermined period of time during the use of such rechargeable battery”, persons skilled in the art can understand that the above statement “a selected current condition or a selected voltage condition” means an arbitrary current condition or voltage condition that is set as required as a condition for calculating the zero-current state potential (V_{zero}) in a rechargeable battery. Regarding (b), it is apparent that the “zero-current state potential (V_{zero})” means the potential when the current is zero (not flowing). Furthermore, persons skilled in the art can understand that “calculating the net coulomb charge charged/discharged (ΔQ_{ap}) of the rechargeable battery based on the amount of change (ΔV_{zero}) of the said zero-current state voltage (V_{zero})” means calculating ΔQ_{ap} from ΔV_{zero} , using the function for the amount of change of the zero-current state potential (ΔV_{zero}) and

the net coulomb charge charged/discharged, based on the common general knowledge that the charged/discharged net coulomb charge correlates with the amount of change of potential for rechargeable batteries, as well as the common general knowledge that in general, the correlation between variables that correlate with each other can be expressed as appropriate through approximation that has a coefficient previously determined based on known data.

The KIPO determined regarding (a), as a selected current or a selected voltage is determined based on the property of the rechargeable battery, it can be determined that the current or the voltage is sufficiently specified based on the terminology itself. Regarding (b), Even though additional explanation has not been made, the person skilled in the art may clearly understand that the 'zero-current state' means the current, which flows outside the rechargeable battery, is valued as zero, and that the zero-current state has occurred because voltage has been dropped due to the loss of electricity resulted from inward current caused by inward resistance of the rechargeable battery. Further, the above matter is sufficiently implied in the detailed description of the claimed invention.

The CNIPA determined regarding (a), The person skilled in the art cannot determine which current condition or voltage condition the feature "a selected current condition or a specific voltage condition" is intended to define. The person skilled in the art cannot distinguish between the extent of the selected current condition or voltage condition and the extent of other current conditions or voltage conditions which are not selected. Therefore, the person skilled in the art cannot clearly determine the condition under which the zero-current state potential (V_{zero}) shall be calculated from the potential across the terminals of the rechargeable battery. Furthermore, according to the description, the technical feature related to the condition under which the zero-current state potential (V_{zero}) shall be calculated from the potential across the terminals of the rechargeable battery is essential for solving the technical problem to be solved by the invention. On the other hand, regarding (b), because it is apparent that the words have the meanings that they have in the relevant art, the person skilled in the art can understand the statement means calculating ΔQ_{ap} from ΔV_{zero} by using any method or formula well known in the prior art, therefore the feature (b) is apparent and permissible.

The USPTO determined regarding (a), one skilled in the art would appreciate that this statement refers to a "predetermined" [*i.e.*, arbitrary] current or voltage condition. When read in light of the Description, one would understand "condition" to refer to a magnitude or to a degree of fluctuation in magnitude. Regarding (b), one skilled in the art would understand that an amount of change in zero-current state potential (ΔV_{zero}) is to be found between a zero-current state potential (ΔV_{zero}) calculated at two arbitrary times. The language "based on" is also clear and one skilled in the art would understand that there is some established relationship between these two variables, that permits one to be estimated based upon the other.

(iii) Way of thinking on applicable criteria regarding the support requirements
The EPO determined the description puts the skilled person reading the claims and the description in the position to perform the invention using his general knowledge without undue burden.

The JPO determined based on the description, the problem to be solved by the claimed invention is to reduce the influence of measurement errors of the current and in

approximating the charged/discharged amount of net coulomb charge, and to approximate the amount of net coulomb charge charged/discharged in a rechargeable battery more accurately. Based on this, by taking into account the common general knowledge of the invention in the art, persons skilled in the art are able to recognize that the above mentioned issue can be solved by a method for approximating the amount of net coulomb charge charged/discharged in a rechargeable battery by calculating the zero-current state potential that is less influenced by measurement errors of the current and based on the amount of change of the said potential at zero-current state, when a selected current condition or a selected voltage condition is maintained for a predetermined period of time during the use of the rechargeable battery and Claim 1 of the invention contains the above mentioned means.

The KIPO determined whether the claim is supported by the description of the present invention is determined by whether a matter corresponding to the subject of the claim is stated in the description of the present invention, from the view point of the person skilled in the art. In this case, it is obvious for a person skilled in the art that features written in the claim are supported by the statements of the description.

The CNIPA determined the invention of Claim 1 meet the support requirement if the defect has been overcome by adding to claim 1 the technical feature related to the condition disclosed in the description, such as “the condition in which the measured current or the measured potential sustain a selected current condition or a selected voltage condition for a predetermined period of time being a condition in which the said current and voltage have continuously stabilized for a determined period of time”. Because the feature (a) is ambiguous, the discussion is done under the presumption that the defect has been overcome. Based on the description, the problem to be solved by the invention is to reduce the influence of measurement errors of the current and in approximating the charged/discharged amount of net coulomb charge, and to approximate the amount of net coulomb charge charged/discharged in a rechargeable battery more accurately. It is determined that in order to solve the above mentioned problem, the description contains the means. Regarding (b), based on the description and the common general knowledge in the art, the person skilled in the art can reasonably predict that all methods and formula disclosed in the description and in the prior art that are capable of calculating ΔQ_e from ΔV_{zero} can solve substantially the same technical problem and achieve substantially the same expected effects. Then the feature (b) in claim 1 can be allowed.

The USPTO determined regarding the step of “calculating the estimated amount of net coulomb charge charged/discharged (ΔQ_e) of the rechargeable battery based on the amount of change (ΔV_{zero}) of the said zero-current state potential (ΔV_{zero})” neither the claim nor the Description describe how to calculate the amount of change (ΔV_{zero}) of the said zero-current state potential (ΔV_{zero}) of the “battery that is the object of the measurement.” As such, the Description does not demonstrate that, at the time the invention was filed, Applicant knew what other (ΔV_{zero}) was to be used in carrying out the method. Not even one embodiment is described.

3. Case Study 6

(1) Summary of the results

With regard to the clarity requirements, the CNIPA determined the claimed invention in Case Study 1 meets the requirements while the EPO, the JPO, the KIPO and the USPTO determined it does not meet the requirements. Also, with regard to the support requirements, the KIPO determined the claimed invention in Case Study 1 meets the requirements while the EPO, the JPO, the CNIPA and the USPTO does not meet the requirements.

(2) Comparative study on ways of examinations at the IP5 Offices

(i) Term to be examined

IP5 Offices considered if the invention of Claim 1 is unclear because of the statement in Claim 1, which does not identify any structural relationship between “stamp blocks having stamps on upper surfaces thereof,” “stamp units for printing dates,” “grooves,” “a stamp case,” and “stamp bases” or not?

(ii) Way of thinking on applicable criteria regarding the clarity requirements

The EPO determined the mere listing of structural elements without any definition of the interrelation and arrangements in which the parts are put into working with each other does not allow the skilled person to understand how the device is put into working. The present “list” format claim including very little or no information on the function of particular feature e.g. “grooves” renders the claim difficult to interpret. In view of the problem to be solved as given in the description, the problem to be solved by the invention is to provide a stamping device suited for printing dates on business cards stored inside a business-card case. “When setting dates, users change each of the stamp units in the stamp case accordingly with their fingers or by using a tool such as tweezers. They slide the stamp blocks in the grooves to arrange dates by year, a month, and a day” is an essential feature of the invention. Moreover, there is not mentioned any printing substance (for example ink) that is applied to the card to make the date visible on the business card; it is not clear how the ink is applied to the stamps in order to transfer the ink from the stamps onto the business card afterwards.

The JPO determined when looking at the descriptions of “stamp block having stamps on upper surfaces thereof,” “stamp units for stamping dates,” “grooves,” “a case,” and “a base,” no structural relationship between each of them is stated. Based on this, even though taking into account the statement of the description and the drawings as well as the common general knowledge in the art, the technical meaning of a matter specifying the invention, i.e. the function or role that these elements play in the invention of Claim 1, is incomprehensible to a person skilled in the art. Furthermore, in the case of inventions that are stamping devices, it is common general knowledge in the art that the structural relationship between each of the parts differs significantly depending on the technical meaning of each part. When considering this common general knowledge, it is evident that the matters are deficient for persons skilled in the art to understand the structural relationship among each of the above-mentioned matters.

The KIPO determined Claim 1 does not establish a stamping device, a stamp unit, grooves, a systematic connection between a case and a base or working processes, but simply lists each component of which the claimed invention is consisting. Therefore, it shall be determined that the person skilled in the art cannot arrive at the present invention ‘the

input device with which a date is inserted in the business card' based on the concerned description.

The CNIPA determined in claim 1, the subject matter indicates clearly that this is a product claim. And in this product claim, the features such as "stamp block", "stamp unit", "grooves", "case", and "base" which be used to define the product "stamping device" are structural features. A person skilled in the art can understand the category of claim 1, and the main components of the stamping device defined in claim 1. The technical features used in claim 1 all have definite meaning in the art, and they will not define different scope of protection in claim 1 or make the scope of claim 1 unclear. In the case of a stamping device, it is common general knowledge in the art that the structural relationship between each of the parts, a person skilled in the art would understand the possible relationship among those parts stated in the claim 1.

The USPTO determined the only material set forth is a "listing" of components – 1) stamp blocks having numerical characters on the upper surfaces thereof; 2) stamp units for stamping a date; 3) grooves; 4) a case and 5) a base and no structural relationship/interconnection is set forth for any of the components. Looking at the claim, one of ordinary skill in the art would not comprehend how these components cooperate together to result in a "stamping device". Even given the general knowledge of these common components in print devices, claim 1 gives no guidance whatsoever as to how these components work/function together to accomplish the desired result.

(iii) Way of thinking on applicable criteria regarding the support requirements

The EPO determined even if all the features of claim 1 find a support in the description, the claim is however not supported by the description because essential feature(s) for solving the problem to be solved as expressed in the description are missing in the claim, i.e. the description is teaching a different set of essential features to the claim and so does not support it in the sense of Article 84 EPC. Specifically at least the relationship between the grooves and the stamp units for setting a date should be mentioned in the claim. It is also noted that it is not disclosed in the whole text how printing substance (for example ink) is applied to the stamps in order to transfer the printing substance from the types to the business card afterwards.

The JPO determined based on the statement of the description, the problem to be solved by the claimed invention is to provide a stamping device suitable for stamping dates on business cards stored in a business-card case. However, it is recognized that Claim 1 does not include any statement of means to solve the above-mentioned problem, including the structural relationship among "stamp block having stamps on upper surfaces thereof," "stamp units for stamping dates," "grooves," "a case," and "a base" of the stamping device.

The KIPO determined even though a detailed description of the invention states the composition and the working principle with respect to 'a stamping device to stamp the date into a business card', it is determined that to embody a stamping device of the claim based on a detailed description of the invention has neither generalized nor extended beyond the scope of the description of the invention from the view point of the person skilled in the art, and that the person skilled in the art can understand the composition of and the working effect of the subject of the claim.

The CNIPA determined according to statement of the description, the problem to be solved by the claimed invention is to provide a stamping device suitable for stamping dates on business cards stored in a business-card case. As a means to solve the above-mentioned problem, the description and the drawings state a stamping device comprising: stamp units for stamping dates which have connecting structures so that plural stamp blocks having stamps on upper surfaces thereof are connected and can move up and down; a case in which a number of the above-mentioned stamp units is inserted into grooves that are formed concentrically in the case; and a set of bases fixed in a predetermined position in the grooves formed in the above mentioned case, in order to position the above mentioned stamp blocks for setting dates, which are positioned higher than other stamp blocks. And a person skilled in the art can recognize that some other connecting relationships cannot solve the problem. Based on the above, the scope of claim 1 is too broad to be supported by the description of the invention.

The USPTO determined Figures 1-3 and the description (lines 3-18) set forth an operable embodiment of the stamp device and the structural relationship between the 5 major components are set forth to provide a complete working device. However, since claim 1 does not include any of the structural relationship between the components, the claim encompasses more than the description can support. In addition, claim 1 does not include/provide for a solution/means to solve the problem at hand. The simple listing of components do not provide for a device to accomplish the stated solution.

6. IP5 Users' Opinion on IP5 Offices' Case Studies (Case 4-6)

1. User's Stance¹

- Various kinds of opinions were sent from IP5 users regarding Cases 4-6.
- It seemed difficult to summarize to unified users' opinion.

2. Results of user's review

	Clarity Requirement Sufficiency	Support Requirement Sufficiency	Major Opinion
Case 4	Same number of Yes and No	Relatively large number of Yes	<ul style="list-style-type: none"> • Claim identifies the function of each component of the "character input device" and the relationship of the components. • The specification does not describe any particular structure or steps to perform the broadly recited function of "means for..." elements.
Case 5	Relatively large number of No	Vary among Yes, No, and Both	<ul style="list-style-type: none"> • A person skilled in the art would know the bounds of the claim. The claim would cover any case where a current or voltage is evaluated to determine whether it meets some criteria. • "Specific current condition or voltage condition" is insufficient to be understood by PHOSITA².
Case 6	Relatively large number of No	Relatively large number of Yes	<ul style="list-style-type: none"> • The Specification and Figures show what is meant by each term. What is shown in the specification and Figures would likely address any concerns with ambiguity. • Since there is no description about the connection between the configurations, the range of "typing device" according to the present invention cannot be specified and it is unclear.

¹ User's stance was compiled by the following associations in each county: American Intellectual Property Law Association (AIPLA), BusinessEurope (BE), Intellectual Property Owners Association (IPO), Japan Intellectual Property Association (JIPA), Korea Intellectual Property Association (KINPA), and Patent Public Advisory Committee (PPAC).

² PHOSITA = Person Having Ordinary Skill In The Art

7. Summary of IP5 Offices' Case Studies (Case 4-6)

1. Overview of judgment by users and IP5 Offices for each case

		User	EPO	JPO	KIPO	CNIPA	USPTO
Case 4	Clarity	Same number of Yes and No	Yes	Yes	Yes	Yes	Yes
	Support	Relatively large number of Yes	Yes	Yes	Yes	Yes	Yes
Case 5	Clarity	Relatively large number of No	No	Yes	Yes	No	Yes
	Support	Vary among Yes, No, and Both	Yes	Yes	Yes	Yes	No
Case 6	Clarity	Relatively large number of No	No	No	No	Yes	No
	Support	Relatively large number of Yes	No	No	Yes	No	No

2. Detail of judgment by users and IP5 Offices for each case

(1) Case 4

IP5 Offices determined that Case 4 satisfied the clarity requirement based on the reasons below.

- The ‘means for’ formulation is well established in the Computer Implemented Inventions field. The EPO Guidelines provide clear instructions on how to deal with those cases. (EPO)
- “Means for...” is considered to be means which persons skilled in the art can understand by taking into account the statement of the claim and the common general knowledge. (JPO)
- The person skilled in the art could clearly understand the statement “means for...”, taking into account a detailed description or drawing(s). (KIPO)
- By taking into account the statement of the claim and the common general knowledge in the art, what “means for ...” exactly means can be clearly understood by persons skilled in the art. (CNIPA)
- There is sufficient description on how to program the computer to perform the necessary steps described in the specification. (USPTO)

Further, IP5 Offices determined that the claim satisfied the support requirement because the matters stated in the claims were sufficiently disclosed in the specification (EPO, JPO, KIPO, CNIPA) or because the specification disclosed a computer and algorithm to achieve the claimed function (USPTO).

According to users’ opinions, there were such judgments that a person skilled in the art could understand the subject matter based only on the claims and the clarity requirement was satisfied, and that “means for ...” was not sufficiently disclosed and the support requirement was not satisfied.

All IP5 Offices determined that Case 4 satisfied both the clarity requirement and support requirement, though the determination processes varied between those determining clarity based only on the claim and those taking into consideration the disclosure in the specification referring the meaning of ‘means for’ formulation in the field of computer implemented inventions. It seems that some users’ opinions that the support requirement was not satisfied were also based on whether the disclosure was sufficient for computer implemented inventions.

(2) Case 5

IP5 Offices’ judgments varied in the issue (a) on clarity. EPO and CNIPA determined that the specific condition was not clear in the claim though it can be understood based on the specification; but JPO, KIPO, and USPTO determined that a person skilled in the art could understand the specific condition based only on the claims or by taking the specification into consideration. IP5 Offices’ judgments varied also in the issue (b) on clarity, EPO determined that the examiner would likely consider that the method step does not clearly indicate how the zero-current state voltage was calculated in the claim itself; but JPO, KIPO, CNIPA, and USPTO determined that how to calculate the zero-current state voltage could be understood based on the specification or the common technical knowledge.

IP5 Offices’ judgments varied also in the support requirement for Case 5. EPO, JPO, and KIPO determined that the specification supports the claim enough for a person skilled in the art to enable disclosure. CNIPA determined that, if the defect related to the issue (a) had been overcome, the technical feature related to the condition would be disclosed in the specification, and the definition related to the issue (b) can reasonably be predicted by a person skilled in the art and thus allowable. USPTO determined that the claim did not satisfy the support requirement, because neither the claim nor the specification described how to calculate the amount of change of the zero-current state potential.

Many of the users who determined that the claim was unclear indicated that “a specific current condition or a specific voltage condition” cannot sufficiently be understood. Users’ opinions on the support requirement varied. There were such opinions that the claims would cover any case when focusing on “a specific current condition or a specific voltage condition,” and that the specific condition was not sufficiently disclosed.

As for IP5 Offices, three Offices determined that either the clarity requirement or support requirement was not satisfied, and two Offices determined that both the clarity requirement and support requirement were satisfied. It seems that the interpretation of the claim varied among IP5 Offices depending on the extent to which the specification can be taken into consideration. Many users determined that the wording “a specific current condition or a specific voltage condition” was unallowable.

(3) Case 6

The IP5 Offices determined that Case 6 does not satisfy at least any of the clarity requirement and support requirement based on the reasons below.

- The claim is unclear because essential features are missing, and further, what should be in the claim is neither mentioned nor supported. (EPO)
- The technical meaning of the structure is incomprehensible to a person skilled in the art and the claim is unclear, even though taking the common general knowledge into

account. The claim does not include any statement of means to solve the problem and does not meet the support requirement. (JPO)

- A stamping device of the claim can be embodied based on a detailed description of the invention and thus the claim is supported by the detailed description. However, it is determined to be unclear because the claim simply lists each component and a person skilled in the art cannot arrive at the present invention. (KIPO)
- The claim is clear because a person skilled in the art can understand the main components of the stamping device. However, the scope of the claim is too broad to be supported by the description of the invention. (CNIPA)
- The claim is unclear because it does not include any of the structural relationship between the components, and the claim is not supported because it encompasses more than the description can support. (USPTO)

According to users' opinion, there were such judgments that the claim was unclear because the relation among the components was not described, and that what were indicated by each term in the claim were supported in the description and drawings.

IP5 Offices' judgments were the same in the opinion that Case 6 does not satisfy any of clarity requirement and support requirement, and the claims like Case 6 are generally unallowable. Some users determined that Case 6 satisfied the support requirement, but many users determined that Case 6 did not satisfy the clarity requirement. Accordingly, the claims such as Case 6 seem to be unallowable in many cases.

3. Summary of Case 4-6: written requirement in PHEP

In PHEP, the discussion has been advanced based not only on the opinions of the Offices but also the opinions of the users.

The opinions from IP5 Offices and users on Case 4-6 suggested that, though "means for..." claims may be allowable at IP5 Offices in some cases for computer implemented inventions, users' responses showed that some users wished clearer expression in the claims.

Further, it was proved that how much the description was taken into consideration in the judgment and the definition of a person skilled in the art were different among IP5 Offices depending on the technical fields, in a case where the claims include an expression such as a specific condition or an operationally specified calculation method. Regarding case 5, many users had concerns about using functional language in the claims.

IP5 Offices have a common opinion that the claims are unallowable in many cases if they do not clearly state the relation of each component of a device. Also for users, such claims do not seem to be preferable.

As a result of Case Studies, it was suggested that:

- there are some wording of the claim, which are allowable in some particular technical fields such as computer implemented inventions;
- the technical level of a person skilled in the art in the fields of the claimed invention should be disclosed sufficiently in the specification, in a case where the claims include a specific condition or an operationally specified calculation method; and
- the relation among each component should be specified in the claims of a device, for example.

[End of Document]