

Appendix 2

Case 2

CONTENTS

	PAGE
Claim and description of the Application	2
Drawings of the Application	9
Published Prior Art 1	11

Case 2

[Claim and Description
Of the Application]

SPECIFICATION

1. Title of Invention: Spring Structure

2. CLAIM

A spring structure comprising circular rubber plates and metallic plates that are alternately laminated, wherein the following conditions are met:

- (1) $t \leq 5\text{mm}$,
- (2) $D/t \leq 50$,
- (3) $8 > D/h > 5$, and
- (4) the hardness of each rubber plate is less than 40,

Wherein the thickness of each rubber plate is defined as “t,” the diameter of each rubber plate is defined as “D”, and the total thickness of the rubber plates is defined as “h.”

3. Detailed Description of the Invention

(1) Technical Field

The present invention relates to a spring structure capable of supporting any structure that has a substantial weight by means of the buffering function of the spring structure itself.

(2) Background Art

Seismic vibrations that damage buildings are divided into horizontal and vertical vibrations. Of these, vertical vibrations do not severely affect buildings. The crucial issue in the destructive force of earthquakes is the horizontal accelerated velocity. When being subjected to severe horizontal accelerated velocity, buildings individually sway in the directions shown in FIG. 1 (a), (b), and (c). The phenomenon shown in FIG.1 (a) represents a shear deformation that does not cause the pillars on the floors of buildings to expand and/or contract. The phenomenon shown in FIG. 1 (b) represents a bending deformation caused by the expansion and/or contraction of pillars on building floors. The other phenomenon shown in FIG. 1 (c) is the rocking phenomenon that occurs due to the deformation of the ground, but does not cause buildings to deform. When earthquakes actually occur, the simultaneous deformation of buildings occurs in the manner combining the aforementioned deformation shown in FIG. 1 (a), (b), and (c) with each other. Of these, the rocking phenomenon can easily cause buildings to collapse and it generates the utmost destructive force. When applying seismic-resistant design against the three types of deformation cited above, since it is quite essential to provide substantial seismic-resistant strength for tall buildings in order to ensure safety, designing of tall buildings involves much difficulty and construction cost goes up.

Hence, the Applicant has proposed seismic isolation structure as shown in FIG. 2, which

Appendix 2

decreases the horizontal accelerated velocity affecting buildings. As further shown in FIG. 3 and FIG. 4, the spring structures (3) are comprising metallic plates (1) and rubber plates (2) that are alternately laminated. The spring structures (3) are disposed between each building and the base (5) thereof. Each of the spring structures (3) solely generates elastic deformation at local portions of thinly formed rubber plates (2) disposed between individual metallic plates (1). Due to thinness of the rubber plates (2) disposed on each layer, each of the spring structures (3) contains substantial spring stiffness in the vertical direction and insubstantial spring stiffness in the horizontal direction caused by the shear deformation of rubber material. In other words, each of the spring structures (3) possesses a substantial loading capability in the vertical direction and insubstantial spring force in the horizontal direction. As a result of characteristic test on trial samples of the spring structure (3), it was duly confirmed that, due to adequately selected material, dimension, and configuration of rubber plates, it can be demonstrated that the spring ratio between the vertical stiffness of the spring and the horizontal stiffness of the spring can be set to more than or equal to 500. Hence, it is possible for the spring structures (3) to stably support heavy buildings and ensure the safety of the buildings by way of decreasing the deformation, since the spring structures (3) enable the buildings to perform slow swaying movements as shown in FIG. 1 (d) and minimize shear deformation, bending deformation and rocking phenomenon when earthquakes occur.

When designing the spring structures (3), two of the following conditions are practically required.

Firstly, it is essential that the horizontal deformation amount “ δ ” of spring structure shown in FIG. 5 be enough to fully absorb the horizontal movement of the building while the earthquake is underway. This is due to the fact that if the horizontal deformation amount “ δ ” were small, then the spring structures (3) would not be able to fully follow up the earthquake vibration, instead enhancing the overturning moment and the shear strength, cause the rocking phenomenon to easily occur. More specifically, in order to properly cope with earthquake vibrations that comprise considerable long-period ground motion here in Japan, it is quite essential to provide spring structures that have a substantial degree of the horizontal deformation capacity expressed as “ δ/h ” (where “ h ” designates a total thickness of the rubber plates).

The other condition required is that the horizontal spring modulus (i.e., shear spring modulus KH) be able to remain invariable against variation of the vertical load. Otherwise, it will become quite difficult to calculate how building can move while an earthquake is actually occurring. This in turn makes it impossible to design the proper building structures. Even in the case of an identical earthquake vibrating force and an identical weight of building, the vertical load which the spring structures (3) are subjected to is remarkably variable, since it depends on the width L and the height H (of the center of gravity G). This is because the variation of the vertical load is determined by the rocking phenomenon and the overturning moment.

Appendix 2

As described in the above, when designing the spring structures (3), it is quite important to minimize the influence of varied load on the shear spring modulus KH while enhancing the horizontal deformation capability “δ/h.”

Two of the following formulas are known as the shear spring modulus KH used for designing conventional spring structures.

$$KH = \frac{V^2 / h_B}{2 (Kr/n) q \tan (q h_B/2) - V} \dots (1)$$

$$\text{wherein } q^2 = \frac{nV}{Kr h_B} \left(1 + \frac{nV}{Ks h_B} \right)$$

- v: Compressive load
- n: Number of rubber plate layers
- h_B: Total thickness of rubber plates
- Kr: Rotational stiffness per rubber plate layer
- Ks: Shear stiffness per rubber plate layer

$$KH = (h / AG + h^3 / 12E I)^{-1} \dots (2)$$

wherein

- h: Thickness of total rubber plates
- E: Total elastic modulus of rubber plates
- A: Cross-sectional area of rubber plates
- G: Shear elastic modulus of rubber plates
- I: Cross-sectional secondary moment of rubber plates

Nevertheless, the above-cited formulas (1) and (2) respectively are set by putting restricted range on the deformation capability “δ/h” and calculating the above-mentioned shear spring modulus KH within the range , and thus the above-mentioned shear spring modulus KH cannot be practically applied when the vertical load has been varied or when incidental variation has actually occurred in the horizontal direction beyond the scope of preset restrictions. Hence, the above-mentioned formulas (1) and (2) are ineffective for coping with earthquake vibration comprising considerable long-period ground motion here in Japan in that substantial horizontal displacement is required for the spring structures.

(3) Object of Invention

Appendix 2

In light of the conventional technical problems, the claimed invention aims to provide improved spring structures, which are capable of providing substantial deformation capability “ δ/h ” and stable shear spring modulus KH that can remain invariable even when the vertical load is actually variable.

(4) Constitution of Invention

The claimed invention is a spring structure comprising circular rubber plates and metallic plates, which are alternately laminated. As shown in FIG. 3 and FIG. 4, when the thickness of each rubber plate is defined as “t,” the diameter of each rubber plate as “D,” and the total thickness of the rubber plates as “h” (when the number of rubber plate layers is expressed as “n,” “h” is expressed as “n x t”), the claimed spring structure meets the following conditions;

$t \leq 5\text{mm}$, $D/t \geq 50$, $8 > D/h > 5$ and the hardness of each rubber plate is less than 40.

(5) Examples

Based on the viewpoint of the restriction on the hardness and the form of the rubber plates in the aforementioned spring structure, since the physical characteristics of the spring structure can be determined by way of specific factors including hardness, elastic modulus, the thickness of each rubber plate layer “t,” the ratio “D/t” (primary form ratio) between the thickness “t” and the diameter “D” of each rubber plate, and the ratio “D/h” (secondary form ratio) between the total thickness “h” and the diameter “D” of the rubber plates, after having conducted various experiments on trial samples, the inventors eventually discovered the practical extent of the factors above to which the aforementioned object could be achieved. The test results proved that the combination of the hardness of the rubber plates with the secondary form ratio “D/h” within the aforementioned factors constitutes a vitally important factor in enhancing the above-mentioned deformation capability “ δ/h ” in particular. The spring structure based on the aforementioned restriction does not belong to any device that has ever been generalized to date. The hardness of the rubber plates thus far used for conventional spring structures is within the range between 50 and 70.

Next, a concrete example of the spring structure satisfying the aforementioned restrictive condition is described below.

Concretely, a thickness “t” of each rubber plate is 6mm, and a diameter “D” is 30~40cm. When the diameter “D” is 30cm, the total thickness “h” of the rubber plates reaches 5cm ~ 6cm. When the diameter “D” is 40cm, the total thickness “h” of the rubber plates reaches 7cm ~ 8cm. The hardness of each rubber plate is reckoned to be 37. The thickness of each metallic plate sandwiched by the rubber plates is 2mm ~ 3mm.

In this case, it is expected that the deformation capability “ $\delta/h \times 100$ ” will reach approximately 300% within the non-destructive area of the spring structure, and approximately 400% within the destructive area thereof. The term “destructive area” designates a specific area wherein the spring

structure exerts an effective seismic-isolation function and then causes the physical characteristics of the spring structure to change.

(6) Effects of Invention

The spring structure incorporating the above-described structure can secure the horizontal deformation amount up to approximately “ $\delta = D/1.5$.” In concrete terms, when each rubber plate is 45cm in diameter, the deformation amount “ δ ” becomes 30cm. When each rubber plate is 60cm in diameter, the deformation amount becomes 40cm. In order to practically cope with earthquake vibrations in Japan, if only 30cm of the deformation amount “ δ ” can be secured, a sufficient seismic-isolation effect may be expected. Since it is considered that provision of the deformation amount by a maximum of 40cm would be appropriate for any contingency, it is anticipated that provision of the spring structure based on the aforementioned restriction will be able to exert sufficient seismic-isolation effect whenever faced with the large-scale earthquakes that can occur in Japan. Further, the shear spring modulus KH provided for by spring structures with the aforementioned conditions is rarely variable even when the vertical load increases approximately threefold. Hence, this facilitates easier calculation of building movement when the spring structure has been incorporated beneath building as an effective base isolation device, thereby providing much advantage for the facilitation of easier designing of buildings.

It should be noted that the aforementioned description refers solely to the application of the claimed spring structure to the base isolation from buildings. However, the claimed spring structure is also applicable as a base isolation device that can be provided for heavy structures such as, for example, large-scale manufacturing plants.

4. Brief Description of Drawings

In the accompanying drawings;

FIG. 1 is an imaginary view for the purpose of explaining various phenomena of the buildings while being impacted by an earthquake.

FIG. 2 is a schematic view of a seismic isolation device with the spring structure.

FIG. 3 is a front view of the spring structure.

FIG. 4 is a plan view of the spring structure.

FIG. 5 is a front view of the spring structure after having been displaced in the horizontal direction.

Explanation of reference numerals shown in the drawings

- (1) Metallic plates
- (2) Rubber plates

Appendix 2

- (3) Spring structures
- (t) Thickness of each rubber plate
- (D) Diameter of each rubber plate

Case 2

[Drawings of the Application]

Fig. 1



Fig. 2

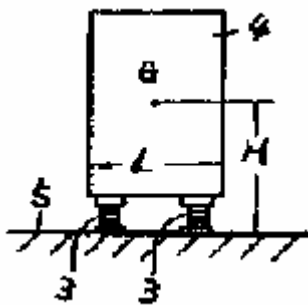

Fig. 3

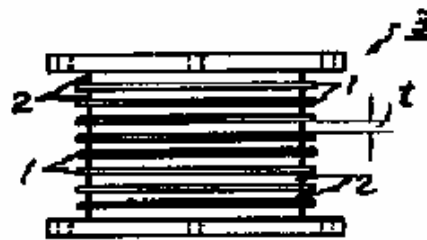

Fig. 4

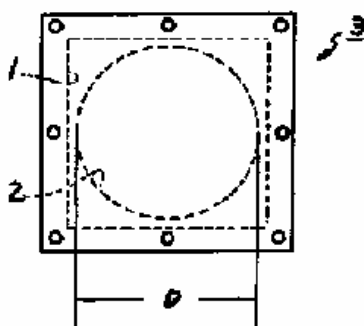
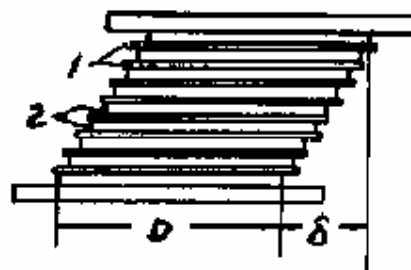

Fig. 5



Case 2

[Published Prior Art 1]¹

¹ TADA Hideyuki, TAKAYAMA Mineo, "Aseismic Isolator ni kansuru kenkyu - sono 7. Jitsudai Isolator no seiteki jikkenn (Study on Aseismic Isolators static experiments conducted with a real-size isolator)", showa 57 nen(1982) shuki taikai (Tohoku) gakujiyutsu kouen kougai syu <kouzoukei>, Shadan Houjin Nihon Kenchiku Gakkai(Architectural Institute of Japan),1982, Aug.,p.785-786

Study on Aseismic Isolators

Static experiments conducted with a real-size isolator

1. Introduction

As reported in the preceding paper, we carried out static experiments with real-size aseismic isolators in pursuit of practical application of the Pad type aseismic isolators. In consequence, we arrived at a certain conviction on the practicability of the above real-size aseismic isolators. The present paper reports on the research of physical characteristics via full-scale application of the above aseismic isolator particularly on the practical loading capability and deformation capability, and further, by way of adding a single-layer trial sample thereto. Each of the experimental aseismic isolators dealt with a sum of 120 units of test sample comprising 3 kinds of rubber plates (see Table 1). The present paper specifically refers to 72 units of rubber plates whose hardness is 37 (see Table 2). The experimental aseismic isolator was named by referring to the formula shown below. D/t designates the form modulus. Each of the experimental aseismic isolators was subjected to compression/ compressive shearing experiments and measured for identifying actual compression shear strength by using a large-scale testing machine.

Formula:

$$A_d - D \times t - n$$

(Wherein, “A”: a composition of rubber,

“d”: hardness of rubber plate,

“D”: diameter of rubber plate,

“t”: thickness of rubber plate,

“n”: number of rubber plate layers.)

For example, “ $A_{37} - 300 \times 5 - 12$ ” means the rubber plate having 37 in hardness, 300mm in diameter, 5mm in thickness, and the number of rubber plate layers is 12.

2. Summary of Experiments

(i) Compression experiments

Each aseismic isolator having a maximum of 180mm in diameter was measured by applying 100ton Amsler type testing machine, whereas each aseismic isolator having a minimum of 180mm in diameter was measured by applying 500ton structural test machine.

(ii) Compressive shearing experiments

Aseismic isolators capable of bearing low load were examined by jointly applying 5ton

compressive shearing machine and 100ton Amsler type testing machine. Whereas aseismic isolators having 250mm and 300mm in diameter and a single-layer aseismic isolator were examined using the two-way loading test machine shown in FIG. 1 which is capable of exerting 30 metric tons of the maximum horizontal output and 50 metric tons of the maximum vertical compressive force at 200 mm of stroke. Further, destruction phase of the sheared aseismic isolators was observed using the large-scale compressive shearing machine capable of exerting 50 metric tons of the maximum horizontal output and 500 metric tons of the maximum vertical compressive force at 600mm of stroke.

3. Results and discussions

(i) Compression experiments

It was confirmed that, relatively to the increased form modulus and the decreased number of the laminated layers, the vertical spring modulus K_v rose up.

(ii) Compressive shearing experiments

It was further confirmed that, relatively to the increased compressive load, there was a tendency of causing the deformation amount to increase against the identical shearing force. However, this tendency is characteristic of the laminated aseismic isolators each having a maximum of 180mm in diameter. Conversely, any increase of the deformation amount was not substantially confirmed in the sheared aseismic isolators having a minimum of 250mm in diameter when the compressive load increased. Strictly speaking, in the case of aseismic isolators having 300mm in diameter, when an increased compressive load “ δc ” was added to the aseismic isolators by 45 ~ 90kg/cm² ($N = 31.8 \sim 63.6t$), it was observed that the sheared deformation amount of the aseismic isolators increased by 5% up to 8%.

Any of the single-layer aseismic isolators (see FIG. 2) proved to have remained in the stable linearity from the initial experimental stage. Any variation of the sheared deformation amount was not confirmed in a specific extent of the compressive load “ δc ” ranging from 23kg/cm² up to 90kg/cm² ($N = 4.0 \sim 15.9t$). On the other hand, it was confirmed that, relatively to the increased form modulus, the deformation amount of the aseismic isolators decreased when being subject to an identical shearing load. Table 2 designates the spring modulus in the low-shearing load.

FIGs 3 and 4 individually designate the results from the compressive shearing experiments and the destruction experiments thereof. As in the case of other laminated aseismic isolators, a tendency to cause degradation of the stiffness was observed from those aseismic isolators having 250mm and 300mm in diameter respectively when deformation rate was within the range between 50% (30mm) and 150% (90mm). (Note: “deformation rate” is expressed as “deformation amount” divided by “total thickness of rubber plates.”) On the other hand, it was also confirmed that the

Appendix 2

stiffness of the tested aseismic isolators was enhanced when the deformation rate exceeded 150% until reaching the eventual destruction thereof (see FIG. 4). The tested aseismic isolators respectively were confirmed partial peeling off after being deformed by 330% (200mm). When the deformation rate reached 400% up to 430% (240mm ~ 250mm), the rubber layers were torn off and the intermediate rubber plates were deformed. Thenceforth, it was no longer possible for the deformed aseismic isolators to bear load thereon.

As in the case of the compressive characteristics, the stiffness of the single-layer aseismic isolator (see FIG. 3) tended to be enhanced monotonously along with the increasing deformation. It was further confirmed that, even when the single-layer aseismic isolator was deformed by 300%, substantially, there was no variation in the horizontal spring modulus. Nevertheless, the partial peeling off in the tested single-layer aseismic isolator was partially observed at the edge of the laminated aseismic isolators when deformation rate exceeds around 300%. Although the destruction does not uniformly occur in accordance with the degree of compressive load, under the present experimental condition, destruction is generated in the tested aseismic isolators when the deformation rate reached 600% up to 800%. It is quite characteristic that, by accompanying sharp rise of the stiffness, any of the tested aseismic isolators incurred the peeling-off adhesive surfaces and the torn-off rubber layers. When large-scale deformation was generated, raised compressive force was observed. It is conceived likely that the above phenomena respectively link with the rise of the horizontal spring modulus. By referring to the above experimental results, the following factors have been confirmed as the compressive shearing characteristics. In the initial stage, any of the tested aseismic isolators exhibited genuinely shearing deformation. In the case of the laminated aseismic isolators each having a maximum of 180mm in diameter, due to its height, the laminated aseismic isolators individually shifted into the bend shearing type deformation until reaching the eventual destruction (refer to the solid line (a) shown in FIG. 5). On the other hand, any of those aseismic isolators having a minimum of 250mm in diameter unexpectedly exhibited negligible $P-\delta$ effect due to stabilized form by way of showing a deformation performance indicated by the solid line (b) of FIG. 5. In place of showing the aspect found in the laminated aseismic isolators, the single-layer aseismic isolator merely exhibited a deformation performance indicated by the solid line (c) of FIG. 5. It was further confirmed that, in any of the above examples, except the fully torn-off result, any of the tested aseismic isolators proved to have exhibited satisfactory self-restoring property.

4. Conclusion

(i) The trial samples of the aseismic isolator realized the following:

Vertical spring modulus K_v / Horizontal spring modulus $K_H = 600 \sim 850$.

Appendix 2

(ii) The following test results were recorded from the compression and the compressive shearing experiments:

Compression experiments: $\delta_c = 700\text{kg}/\text{cm}^2$

Shearing strength via the compressive shearing experiments: $19\text{kg}/\text{cm}^2$

Elongation: 250mm

Based on the above results, it was clarified that the above-specified aseismic isolators could practically be applied to structures built with iron-reinforced concrete structures irrespective of scales.

(iii) As a result of the conduction of the current serial experiments, it has become possible to properly design a constantly stable horizontal spring that can ignore influence of variable compressive force.

Table 1: Characteristics of rubber

Hardness of rubber (JIS-A)	16	19	37
25%modulus (Kgf/cm ²)	1.08	1.27	3.2
50%modulus (Kgf/cm ²)	1.49	1.89	5.5
100%modulus (Kgf/cm ²)	1.98	2.42	8.3
200%modulus (Kgf/cm ²)	2.66	3.33	14.3
300%modulus (Kgf/cm ²)	3.18	4.22	24.5
tensile strength (Kgf/cm ²)	more than 20	74.6	184
shear stiffness (Kgf/cm ²)	1.5	1.67	5.2
elongation percentage (%)	more than 1000	810	630

Appendix 2

Table 2-1: Spring modulus

Number of experimental aseismic isolator	form modulus	total thickness of rubbers	deformation rate(%)	Horizontal spring modulus K_H (kg/cm)				Vertical spring modulus K_V (kg/cm) (E)	spring rate (K_V / K_H)			
				23 (A)	31 (B)	45 (C)	60 (D)		(E) / (A)	(E) / (B)	(E) / (C)	(E) / (D)
A ₃₇ - 130 X 10 - 6	13	60	50	71	51	-	-	9300	131	182	-	-
			100	59	-	-	-		158	-	-	-
A ₃₇ - 150 X 10 - 1	15	10	50	780	760	700	740	65500	84	86	94	89
			100	760	740	700	730		86	89	94	90
A ₃₇ - 180 X 10 - 6	18	60	50	157	134	93	-	27000	172	201	290	-
			100	147	125	85	-		184	216	317	-
A ₃₇ - 150 X 7.5 - 1	20	7.5	50	1060	1030	970	940	106000	100	103	109	113
			100	1000	960	940	920		106	110	113	115
A ₃₇ - 150 X 7.5 - 8	20	60	50	-	100	74	35	19800	-	198	268	566
			100	-	90	65	34		-	220	305	582
A ₃₇ - 150 X 7.5 - 10	20	75	50	71	60	29	-	16100	227	268	555	-
			100	63	51	-	-		256	316	-	-
A ₃₇ - 150 X 6 - 1	25	6	50	1320	1290	1260	1260	148000	112	115	117	117
			100	1250	1210	1180	1180		118	122	125	125
A ₃₇ - 150 X 6 - 10	25	60	50	-	102	82	59	26700	-	262	326	453
			100	-	98	75	49		-	272	356	549
A ₃₇ - 150 X 6 - 13	25	78	50	76	65	41	-	20800	274	330	507	-
			100	63	51	-	-		330	408	-	-

Appendix 2

Table 2-2: Spring modulus

Number of experimental aseismic isolator	form modulus	total thickness of rubbers	deformation rate(%)	Horizontal spring modulus K_H (kg/cm)				Vertical spring modulus K_V (kg/cm) (E)	spring rate (K_V / K_H)			
				23 (A)	31 (B)	45 (C)	60 (D)		(E) / (A)	(E) / (B)	(E) / (C)	(E) / (D)
A ₃₇ - 130 X 5 - 12	26	60	50	87	82	67	-	27000	310	329	403	-
			100	79	73	48	-		342	370	563	-
A ₃₇ - 150 X 5 - 1	30	5	50	1540	1460	1420	1420	175000	114	120	123	123
			100	1420	1380	1370	1370		120	127	128	128
A ₃₇ - 150 X 5 - 6	30	30	50	-	240	224	213	69700	-	290	311	327
			100	-	232	222	210		-	300	314	332
A ₃₇ - 150 X 5 - 12	30	60	50	-	99	75	51	39400	-	398	525	773
			100	-	88	68	43		-	448	579	916
A ₃₇ - 150 X 5 - 15	30	75	50	84	76	54	-	29900	356	393	554	-
			100	73	64	40	-		410	467	748	-
A ₃₇ - 180 X 5 - 7	36	35	50	340	329	320	-	129000	379	392	403	-
			100	317	311	308	-		404	415	419	-
A ₃₇ - 180 X 5 - 12	36	60	50	170	170	153	-	86000	483	506	562	-
			100	164	155	138	-		524	555	623	-
A ₃₇ - 250 X 5 - 12	50	60	50	327	317	307	-	214300	655	676	698	-
			100	297	293	290	-		722	731	739	-
A ₃₇ - 300 X 5 - 12	60	60	50	507	-	500	-	390600	770	-	781	-
			100	463	-	448	-		844	-	872	-

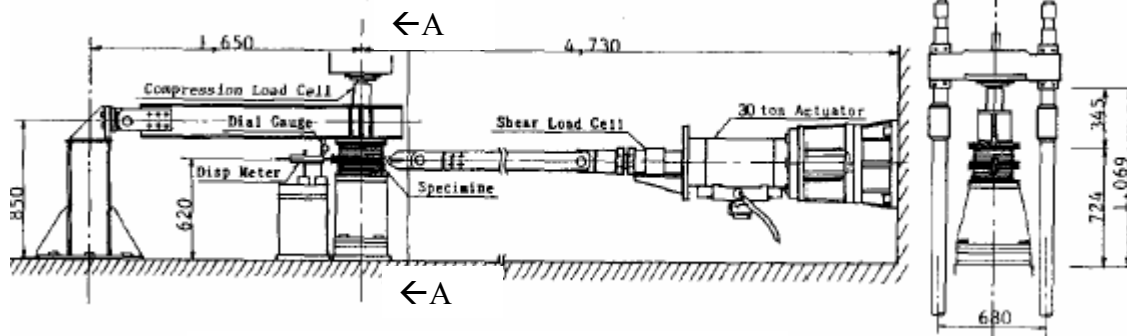

Fig.1 Two-way loading test machine

Side view from
"A-A" position

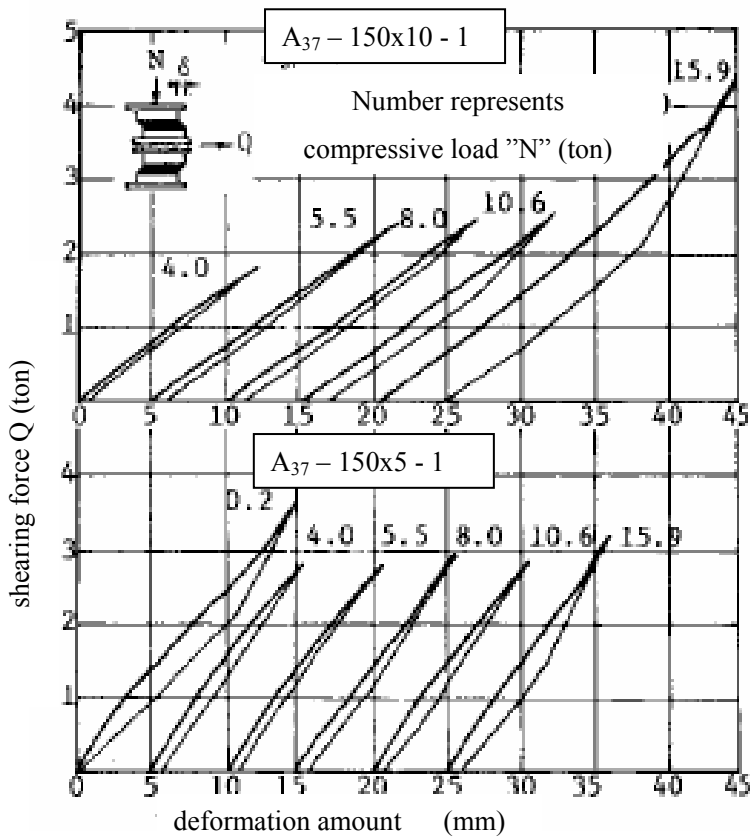

Fig.2 Compressive shearing experiment
on single-layer aseismic isolators

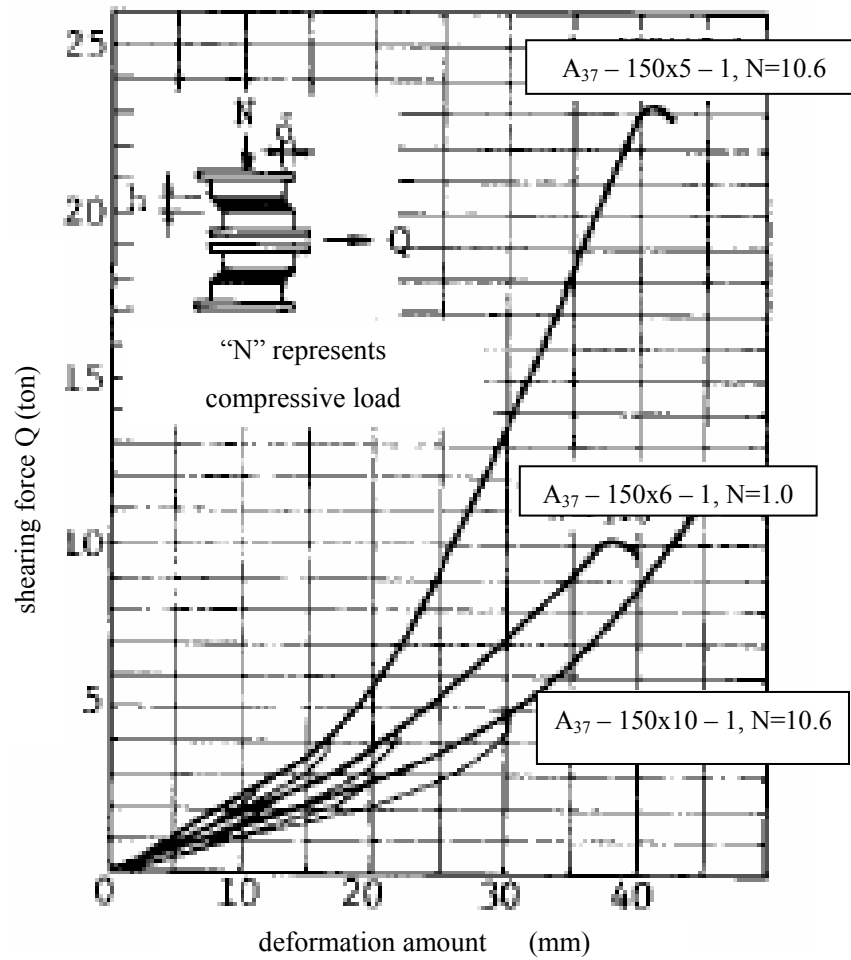

Fig. 3 destruction experiment on single-layer aseismic isolator

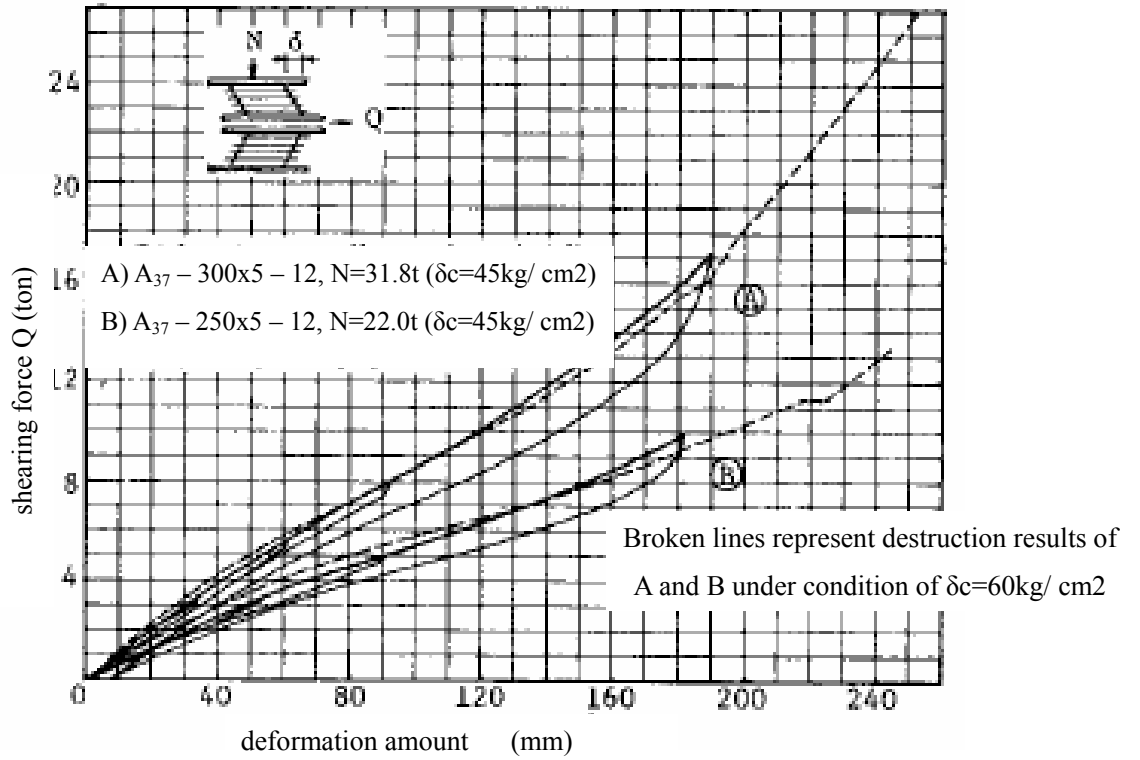
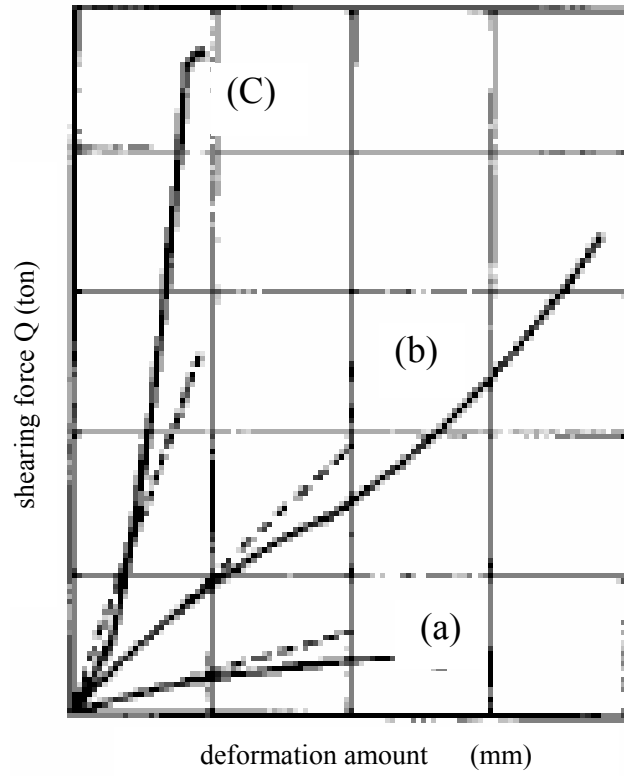

Fig.4 Compressive shearing experiment using a large-scale testing machine



Note: Broken lines represent theoretical figures

Fig. 5 characteristic performance curve in compressive shearing