

Procedures to file a request to the Swedish Patent and Registration Office (PRV) for Global Patent Prosecution Highway (GPPH) Pilot Program

An applicant, who has filed an application to any Patent Office participating in the GPPH pilot program (see [Annex A](#)), may, when filing a corresponding application to the PRV, request accelerated examination by submitting a request form, accompanied by supporting documents. The application must satisfy certain requirements as set out below.

The Offices may terminate the GPPH pilot program if the volume of participation exceeds manageable level, or for any other reason. Ex Ante notice will be published if the GPPH pilot program is terminated.

Part I

GPPH using the national (Paris convention) work products

When filing a request for the GPPH pilot program, an applicant must submit a [request form](#), accompanied by the relevant supporting documents. The requirements for an application to the PRV for accelerated examination under the GPPH are given in section 1 and relevant supporting documentation is discussed in section 2.

1. Requirements

- (a) **Both the PRV application on which PPH is requested and the Office of Earlier Examination (OEE) application(s) forming the basis of the PPH request shall have the same earliest date (whether this be a priority date or a filing date).**

For example, the PRV application (including PCT national phase application) may be either:

(Case I) an application which validly claims priority under the Paris Convention from the OEE application(s) (examples are provided in ANNEX 2, Figures A, B, C, H, I and J), or

(Case II) an application which provides the basis of a valid priority claim under the Paris Convention for the OEE application(s) (including PCT national phase application(s)) (examples are provided in ANNEX 2, Figures D and E), or

(Case III) an application which shares a common priority document with the OEE application(s) (including PCT national phase application(s)) (examples are provided in

ANNEX 2, Figures F, G, L, M and N), or

GPPH using the national work products from the OEE (Case IV) a PCT national phase application where both the PRV application and the OEE application(s) are derived from a common PCT international application having no priority claim (an example is provided in ANNEX 2, Figure K).

- (b) At least one corresponding application exists in the OEE and has one or more claims that are determined to be patentable/allowable by the OEE.**

List of Office actions indicating allowable claims, see [Appendix B](#)

- c) All claims in the PRV application (for which an accelerated examination under the GPPH pilot program is requested) must sufficiently correspond to one or more of those claims determined to be patentable/allowable in the OEE.**

Claims are considered to “sufficiently correspond” where, accounting for differences due to translations and claim format, the claims in the PRV are of the same or similar scope as the claims in the OEE, or the claims in the PRV are narrower in scope than the claims in the OEE. In this regard, a claim that is narrower in scope occurs when an OEE claim is amended to be further limited by an additional technical feature that is supported in the specification (description and/or claims). A claim in the PRV application which introduces a new/different category of claims to those claims indicated as allowable in the OEE is not considered to sufficiently correspond. For example, where the OEE claims only contain claims to a process of manufacturing a product, then the claims in the OLE are not considered to sufficiently correspond if the PRV application claims introduce product claims that are dependent on the corresponding process claims.

Any claims amended or added after the grant of the request for participation in the PPH pilot program need not to sufficiently correspond to the claims indicated as patentable/allowable in the OEE application.

- (d) The PRV has not yet issued a “Final notice” (The heading of the communication is “Slutföreläggande”)**

2. Documents to be submitted

Documents (a) to (d) below must be submitted by attaching to the GPPH request.

- (a) Copies of all Office actions (which are relevant to substantial examination for patentability in the OEE) which were issued for the corresponding application by**

GPPH using the national work products from the OEE ***the OEE, and translations of them***¹.

Either Swedish or English is acceptable as translation language. The applicant does not have to submit a copy of OEE Office actions and translations of them when those documents can be provided via the OEE's [dossier access system](#). If they cannot be obtained by the PRV examiner via the OEE's dossier access system, the applicant may be notified and requested to provide the necessary documents.

(b) *Copies of all claims determined to be patentable/allowable by the OEE, and translations of them*¹.

Either Swedish or English is acceptable as translation language. The applicant does not have to submit a copy of claims indicated to be patentable/allowable in the OEE, and translations thereof when the documents are provided via the OEE's [dossier access system](#). If they cannot be obtained by the PRV examiner via the OEE's dossier access system, the applicant may be notified and requested to provide the necessary documents.

(c) *Copies of references cited by the OEE examiner*

If the references are patent documents, the applicant doesn't have to submit them because the PRV usually possesses them. When the PRV does not possess the patent document, the applicant has to submit the patent document at the examiner's request. Non-patent literature must always be submitted. The translations of the references are unnecessary.

(d) *Claim correspondence table*

The applicant requesting GPPH must submit a claim correspondence table, which indicates how all claims in the PRV application sufficiently correspond to the patentable/allowable claims in the OEE application.

When claims are just literal translation, the applicant can just write down that "they are the same" in the table. When claims are not just literal translation, it is necessary to explain the sufficient correspondence of each claim.

When the applicant has already submitted above documents (a) to (d) to the PRV through simultaneous or past procedures, the applicant may incorporate the documents by reference and does not have to attach them.

¹ Machine translations will be admissible, but if it is impossible for the examiner to understand the outline of the translated office action or claims due to insufficient translation, the examiner can request the applicant to resubmit translations.

GPPH using the national work products from the OEE

Subject: Request for an accelerated examination under the GPPH pilot program

Date of filing: _____

Application number: _____

Title of the invention: _____

Applicant: _____

Office of earlier examination (OEE): _____

This application has the same earliest date (priority date or filing date) as the corresponding OEE application (the application number is _____), and accelerated examination is requested under the GPPH pilot program. For this purpose, the following documents are attached:

- Copies of all Office actions (which are relevant to substantial examination for patentability in the OEE) which were issued for the corresponding application by the OEE and
- Translations of them
- Copies of all claims determined to be patentable/allowable by the OEE and translations of them
- Copies of references cited by the OEE examiner
- Claim correspondence table

Claim correspondence table		
The claim in the PRV	The patentable claim in the OEE	Comments about the correspondence

Documents not submitted, because they are available via the OEE's dossier access system:

PART II

Using Patent Cooperation Treaty (PCT) Work Products

When filing a request for the PCT-GPPH pilot program, an applicant must submit a [request form](#), accompanied by the relevant supporting documents. The requirements for an application to the PRV for accelerated examination under the GPPH are given in section 1 and relevant supporting documentation is discussed in section 2.

1 Requirements

The application which is filed with the PRV and on which the applicant files a request under the PCT-GPPH must satisfy the following requirements:

1.1 The latest work product in the international phase of a PCT application corresponding to the application namely the Written Opinion of International Search Authority (WO/ISA), the Written Opinion of International Preliminary Examination Authority (WO/IPEA), the International Preliminary Report on Patentability (IPRP) or the International Preliminary Examination Report (IPER), indicates at least one claim as patentable/allowable (from the aspects of novelty, inventive step and industrial applicability).

Note that the ISA and the IPEA which produced the WO/ISA, WO/IPEA, IPRP and the IPER are limited to one of the authorities listed in [Appendix A](#), but, if priority is claimed, the priority claim can be to an application in any Office, see example A' in Annex 4 (application ZZ can be any national application). The applicant cannot file a request under PCT-GPPH on the basis of an International Search Report (ISR) only.

In case any observation is described in Box VIII of WO/ISA, WO/IPEA, IPRP or IPER which forms the basis of a PCT-GPPH request, the applicant must explain why the claim(s) is/are not subject to the observation irrespective of whether or not an amendment is submitted to correct the observation noted in Box VIII. The application will not be eligible for participating in PCT-GPPH pilot program if the applicant does not explain why the claim(s) is/are not subject to the observation. In this regard, however, it does not affect the decision on the eligibility of the application whether the explanation is adequate and/or whether the amendment submitted overcomes the observation noted in Box VIII.

1.2 The relationship between the application and the corresponding international application satisfies one of the following requirements (including the case where the Office of the application is the same as the ISA/IPEA of the corresponding international application):

- A. The application is a national phase application of the corresponding international application. (See Figures A, A', and A'' in Annex 4)
- B. The application is a national application which provides the basis of a valid priority claim of the corresponding international application. (See Figure B in Annex 4)
- C. The application is a national phase application of an international application claiming priority from the corresponding international application. (See Figure C in Annex 4)
- D. The application is a national application claiming foreign/domestic priority from the corresponding international application. (See Figure D in Annex 4)
- E. The application is an application derived (divisional application and application claiming domestic priority etc.) from an application which satisfies one of the above requirements (A) – (D). (See Figures E1 and E2 in Annex 4)

1.3 All claims on file, as originally filed or as amended, for examination under the PCT-GPPH must sufficiently correspond to one or more of those claims indicated to be patentable/allowable in the latest international work product of the corresponding international application.

Claims are considered to "sufficiently correspond" where, accounting for differences due to translations and claim format, the claims of the application are of the same or similar scope as the claims indicated to be patentable/allowable in the latest international work product, or the claims of the application are narrower in scope than the claims indicated to be patentable/allowable in the latest international work product.

In this regard, a claim that is narrower in scope occurs when a claim indicated to be patentable/allowable in the latest international work product is amended to be further limited by an additional feature that is supported in the specification (description and/or claims) of the application.

A claim of the application which introduces a new/different category of claims to those claims indicated to be patentable/allowable in the latest international work product is not considered to sufficiently correspond. For example, the claims indicated to be patentable/allowable in the latest international work product only contain claims to a process of manufacturing a product, then the claims of the

application are not considered to sufficiently correspond if the claims of the application introduce product claims that are dependent on the corresponding process claims.

Any claims amended or added after the grant of the request for participation in the PCT-GPPH pilot program need not to sufficiently correspond to the claims indicated as patentable/allowable in the latest international work product.

1.4 PRV has not yet issued a “Final notice” at the time of request under PCT-GPPH (The heading of the communication is “Slutföreläggande”)

2 Documents to be submitted when filing a request for accelerated examination under the PCT-GPPH

The applicant must submit the following documents 2.1-2.4 attached to the request form 2.5 when filing a request under PCT-GPPH. All documents under this paragraph with exception for the cited documents have to be drawn up in or translated to Swedish or English. Machine translations will be admissible, but if it is impossible for the examiner to understand the outline of the translated work product or claims due to insufficient translation, the examiner can request the applicant to resubmit translations.

2.1 A copy of the latest international work product of the corresponding international application

In case the application satisfies the relationship (A)(See Annex 4) the applicant does **not** need to submit a copy of the latest International work product, because a copy of this document is already available in the file-wrapper of the application. In addition, if the copy of the latest international work product is available via [PATENTSCOPE®](#), an applicant does not need to submit these documents, unless otherwise requested by the PRV (WO/ISA and IPRP are usually available as “IPRP Chapter I” and “IPRP Chapter II” respectively after 30 months from the priority date.)

2.2 A copy of a set of claims which the latest international work product of the corresponding international application indicated as allowable

A copy of a set of claims which the latest international work product of the corresponding international application indicated as allowable.

If the copy of the set of claims which are indicated as allowable is available via [PATENTSCOPE®](#) (or the international Patent Gazette has been published), an applicant does not need to submit this document, unless otherwise requested by the PRV. Where translations of the allowable claims are necessary, they must be submitted by the applicant since PATENTSCOPE® does not provide them.

2.3 Copies of references cited in the latest international work product of the corresponding international application

If the references are patent documents, the applicant does not have to submit them because the Office of the application usually has access to them. When the Office of the application does not have access to the patent document, the applicant has to submit the patent document at the examiner's request. Non-patent literature must always be submitted.

Submission of translation of the references is not required. However, applicants will be free to file translations as part of the supporting documentation when initially requesting accelerated examination under the PCT-GPPH to allow prompt consideration of the citations if the applicants so desire.

2.4 Claim correspondence table

The applicant must submit a claim correspondence table to explain the correspondence of claims determined to be allowable in the latest work product of the corresponding international application and all claims in the application (See Annex 1).

2.5 Request form

An applicant should submit a [request form](#) for the accelerated examination under the PCT-GPPH along with the documents referred to in paragraphs 2.1-2.4.

In case the applicant has already submitted the documents mentioned above in paragraphs 2.1 – 2.4 to the PRV through simultaneous or past procedures, the applicant may incorporate the documents by reference and is thus not required to attach the documents.

Procedure for the accelerated examination under the PCT-GPPH

The applicant files a letter requesting accelerated examination under the PCT-GPPH Pilot Program to the PRV, including the relevant supporting documents and a completed [request form](#).

The PRV decides whether the application can be entitled the status of accelerated examination under the PCT-GPPH when PRV receives a request with the documents stated above. When PRV decides that a request is acceptable, the application is assigned a special status for accelerated examination.

If the request does not meet all the requirements set forth above, the applicant will be notified and the defects in the request will be identified. The applicant will be given opportunity to correct the request. If the defect(s) are not corrected, the application will await action in its regular turn.

ANNEX 1

Examples for the claim correspondence table

The claims in the following cases are considered to “sufficiently correspond”.

EX.1

Claims in the international phase	PRV claims	Comment
1	1	The PRV claim has the additional component on the claim that is determined to be patentable in the PCT application.

Allowable claim, corresponding PCT-appl.	Claim, national appl.
<p>A system for presenting a container storing at least one article to a processing tool, comprising:</p> <p>(a) a load port, including:</p> <p>a frame having an opening;</p> <p>a support structure being adapted to receive a container, and</p> <p>a drive mechanism for moving said support structure substantially vertically between a first height and a second height; and</p> <p>(b) a conveyor for movably supporting the container substantially along a container transport plane;</p> <p>wherein a container traveling on said conveyer moves unobstructed over said support structure when said support structure is located in said second height,</p> <p>wherein the container traveling unobstructed does not contact said support structure while traveling over said support structure located at said second height,</p> <p>wherein said support structure, when located at said second height, is located below said transport plane.</p> <p><i>*This additional part is NOT included in the allowable claim but it is included in the description of the national application</i></p>	<p>A system for presenting a container storing at least one article to a processing tool, comprising:</p> <p>(a) a load port, including:</p> <p>a frame having an opening;</p> <p>a support structure being adapted to receive a container, and</p> <p>a drive mechanism for moving said support structure substantially vertically between a first height and a second height; and</p> <p>(b) a conveyor for movably supporting the container substantially along a container transport plane;</p> <p>wherein a container traveling on said conveyer moves unobstructed over said support structure when said support structure is located in said second height,</p> <p>wherein the container traveling unobstructed does not contact said support structure while traveling over said support structure located at said second height,</p> <p>wherein said support structure, when located at said second height, is located below said transport plane,</p> <p><u>wherein said support structure, when located at said first height, is located above said transport plane*</u></p>

EX.2

<i>Claims in the international phase</i>	<i>PRV claims</i>	<i>Comment</i>
1	1	Same
none	2	<i>The PRV claim2 is dependent on the PRV claim1, which has been determined to be patentable in the PCT application.</i>

Allowable claim, corresponding PCT-appl.	Claim, national appl.
1. A nitride-based semiconductor device comprising: a first semiconductor layer, consisting of either an n-type nitride-based semiconductor layer having wurtzite structure or an n-type nitride-based semiconductor substrate having a wurtzite structure; and an n-side electrode formed on a back surface of said first semiconductor layer, wherein a dislocation density is not more than $1 \times 10^8 \text{ cm}^{-2}$ in the vicinity of the interface between said first semiconductor layer and said n-side electrode, and contact resistance between said n-side electrode and said first semiconductor layer is not more than $0.05 \Omega \text{ cm}^2$	1. (Same)
2. (None)	2. The nitride-based semiconductor device according to claim 1, wherein said first semiconductor layer includes an n-type dopant.*

* This additional part is NOT included in the allowable claim
but it is included in the description of the national application

PCT-GPPH REQUEST

Request for Accelerated Examination at the PRV using the PCT international work products under the Global Patent Prosecution Highway Program (GPPH).

If this request concerns a national continuation of an international application where all formal requirements are fulfilled, this request is regarded as an indication from the applicant to permit PRV to immediately launch the search and examination work in the application concerned (cf. Swedish Patent Act, 33, 34§§ and Swedish Patent Decree, 58§). No further indication from the applicant is necessary.

SE application number:.....

Corresponding PCT application number:.....

For the purposes of participation in the GPPH, the following documents should be attached/are required:

1. Either:
 - 1a) A copy of WO-ISA or IPER and translation thereof in English or Swedish
or
 - 1b) Request to obtain documents in 1.1 via PATENTSCOPE®

2. Either:
 - 2a) A copy of all claims determined to be patentable/allowable by the ISA or IPEA
or
 - 2b) Request to obtain documents in 2.1 via the PATENTSCOPE®

3. Translation of the documents in 2. in English or Swedish.

4. Copies of all documents cited in the WO-ISA or IPER (except for patent documents)

5. Comments to Box VIII, where applicable.

6. Claims correspondence table

ANNEX 2

A A case meeting requirement (a) (I) - Paris route -

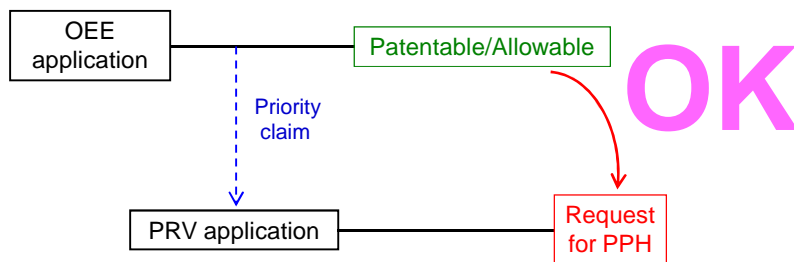

B A case meeting requirement (a) (I) - PCT route -

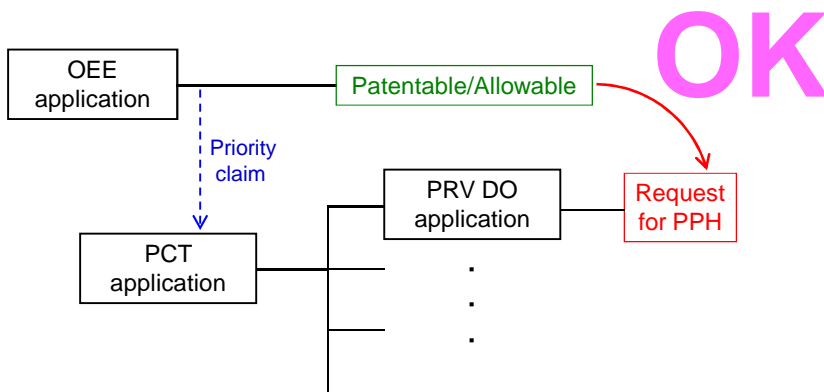

C

A case meeting requirement (a) (I)

- PCT route, Domestic priority -

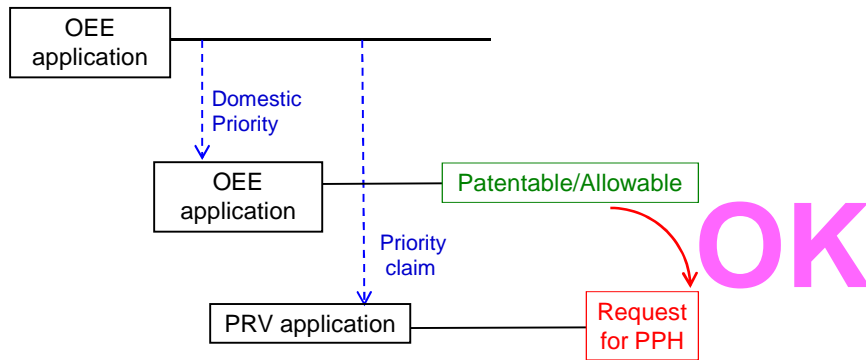

D

A case meeting requirement (a) (II)

- Paris route -

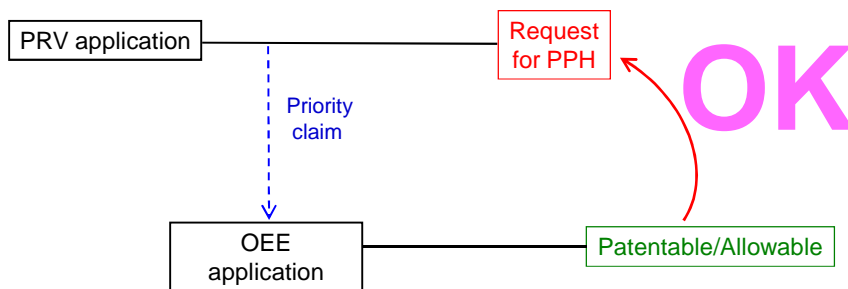

E

A case meeting requirement (a) (II) - PCT route -

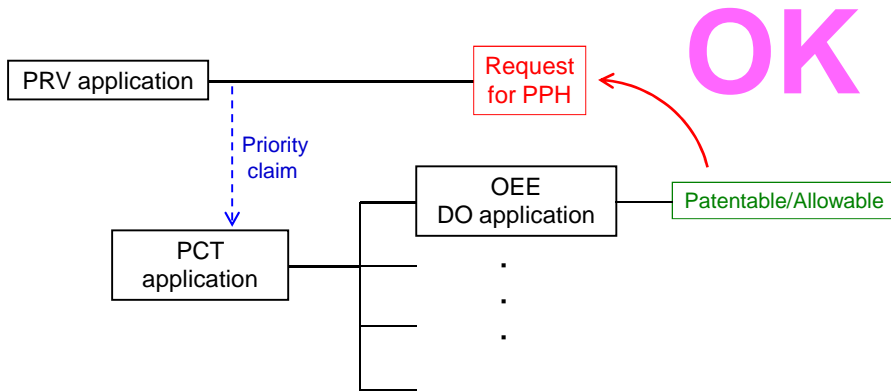

F

A case meeting requirement (a) (III) - Paris route, but the first application is from the third country -

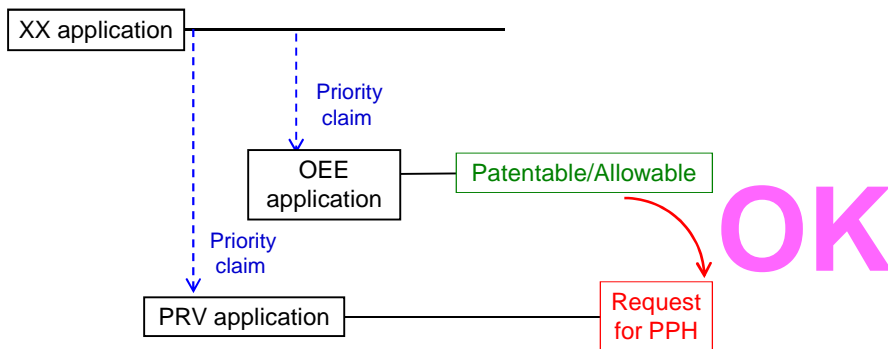

XX : the office other than the OEE

G

A case meeting requirement (a) (III)

- PCT route, but the first application is from the third country -

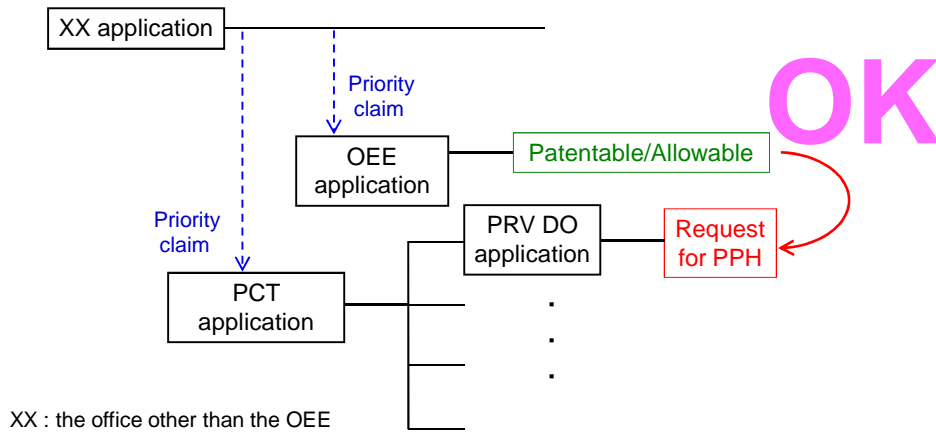

H

A case meeting requirement (a) (I)

- Paris route & Complex priority -

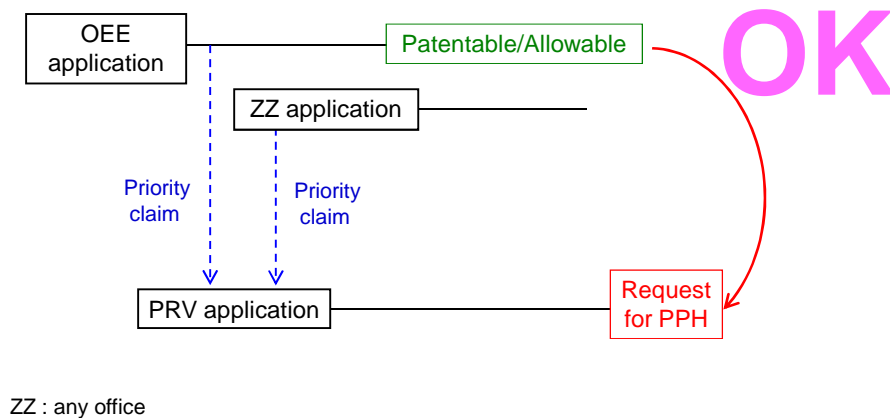

I A case meeting requirement (a) (I)
- Paris route & divisional application -

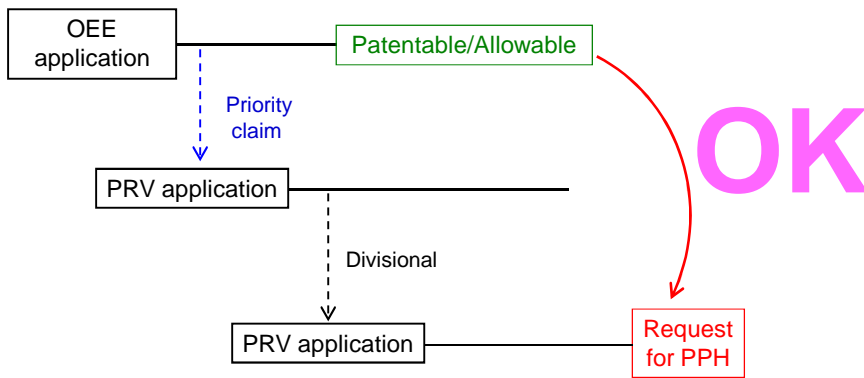

J A case meeting requirement (a) (I)
- PCT route -

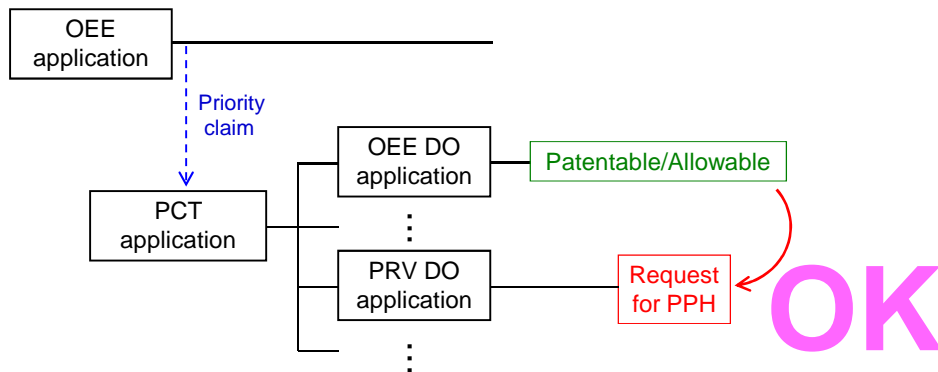

K A case meeting requirement (a) (IV)
- Direct PCT route -

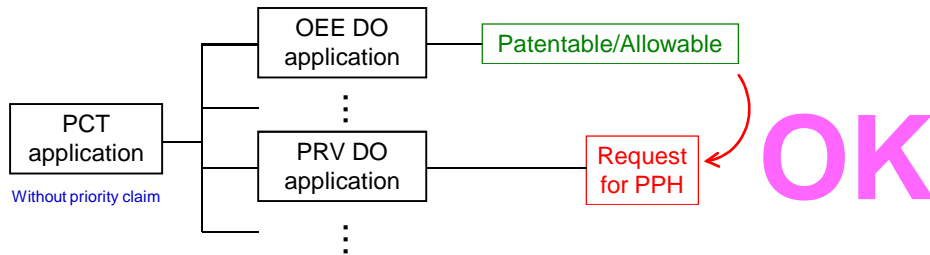

L A case meeting requirement (a) (III)
- Direct PCT & Paris route -

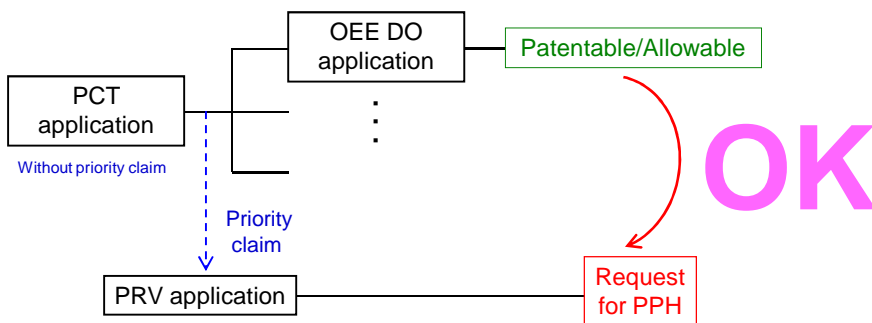

M A case meeting requirement (a) (III)
- Direct PCT & PCT route -

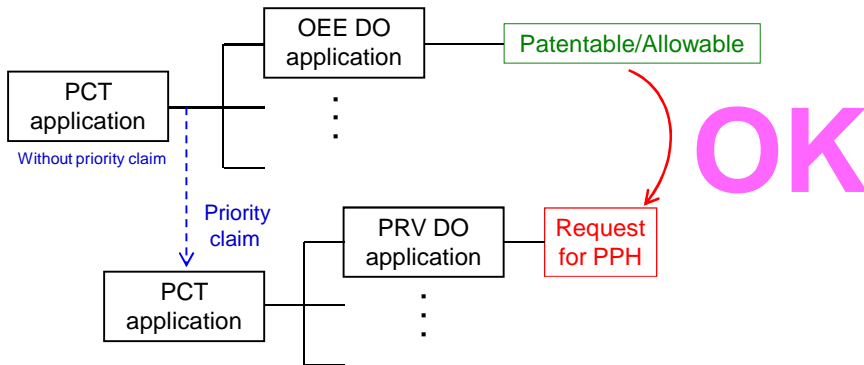

N A case meeting requirement (a) (III)
- Direct PCT & PCT route -

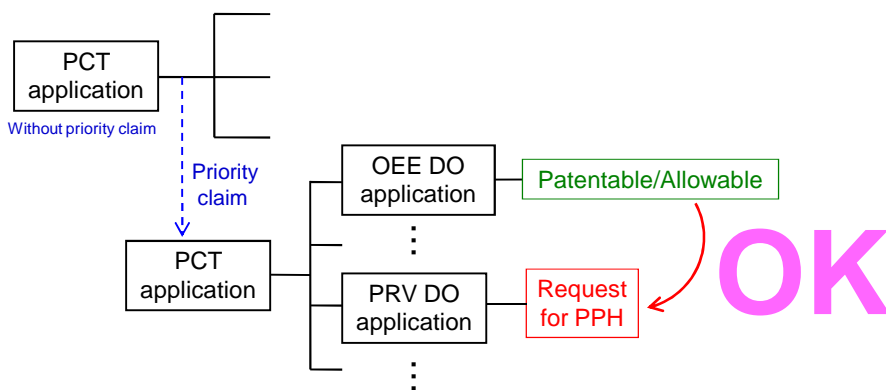

ANNEX 4

(A) The application is a national phase application of the corresponding international application.

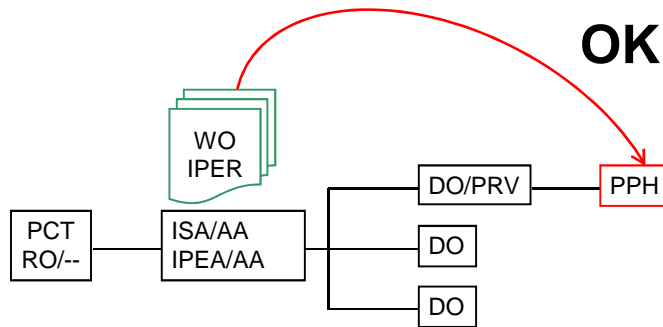

AA=One of the authorities listed in Appendix A

(A') The application is a national phase application of the corresponding international application.
(The corresponding international application claims priority from a national application.)

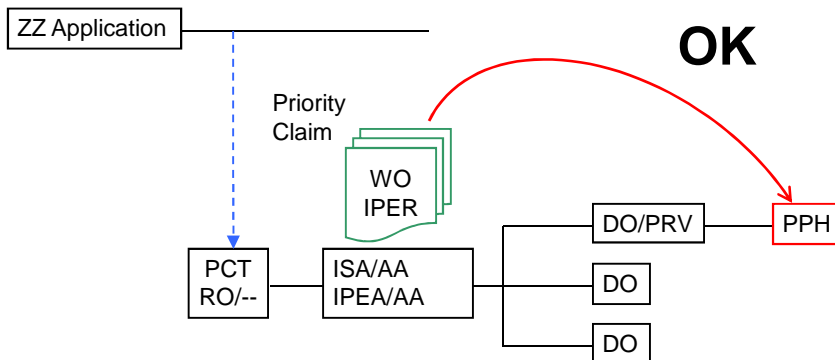

AA=One of the authorities listed in Appendix A

ZZ=any office

(A'') The application is a national phase application of the corresponding international application.

(The corresponding international application claims priority from an international application.)

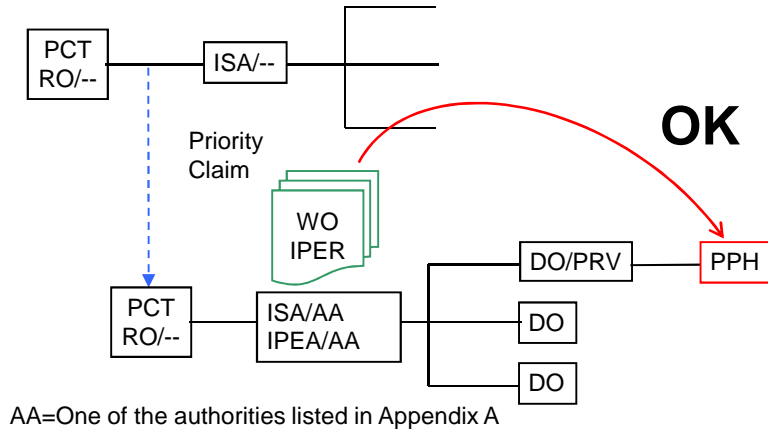

(B) The application is a national application as a basis of the priority claim of the corresponding international application.

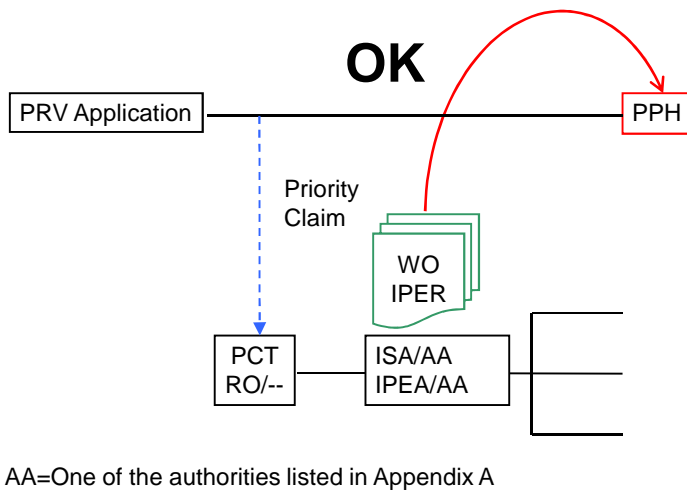

(C) The application is a national phase application of an international application claiming priority from the corresponding international application.

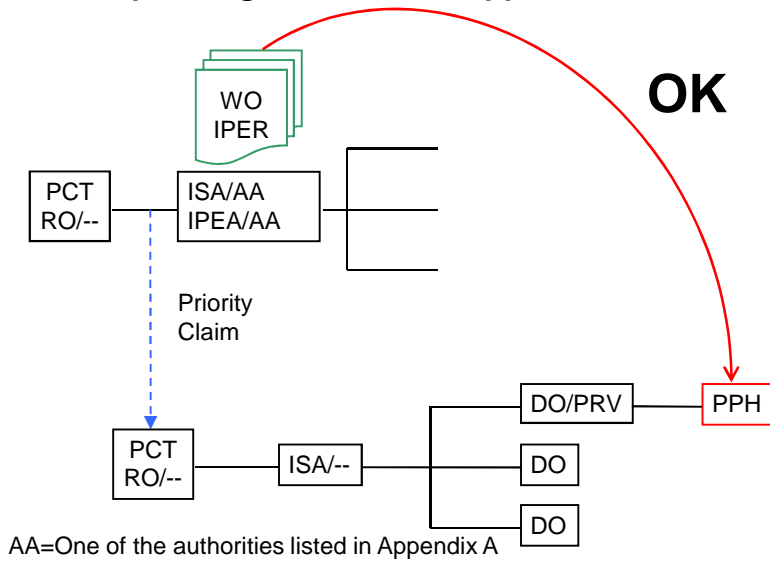

(D) The application is a national application claiming foreign/domestic priority from the corresponding international application.

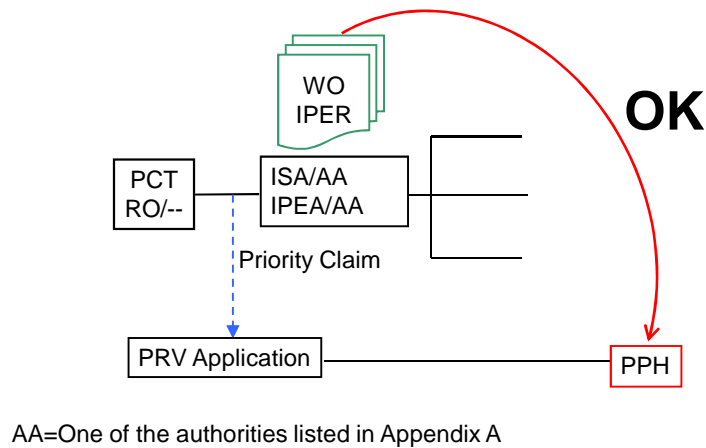

(E1) The application is a divisional application of an application which satisfies the requirement (A).

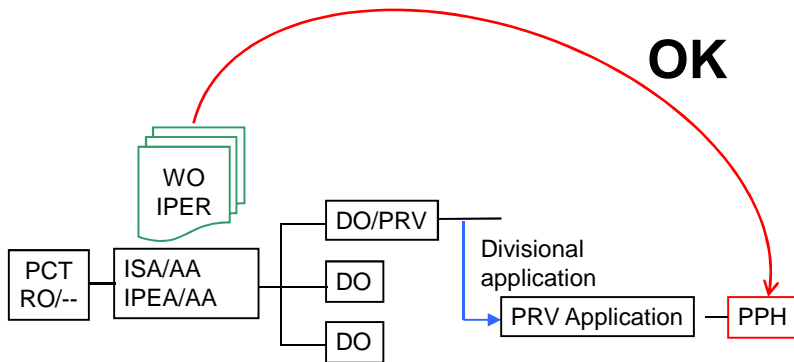

AA=One of the authorities listed in Appendix A

(E2) The application is an application claiming domestic priority from an application which satisfies the requirement (B).

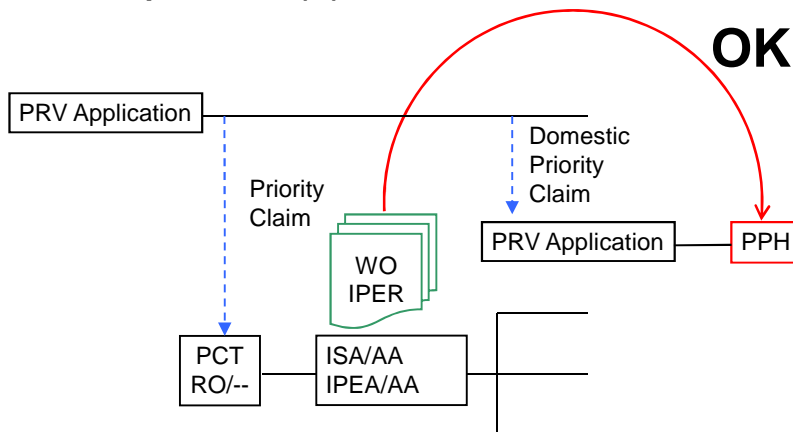

AA=One of the authorities listed in Appendix A